

(No Model.)

2 Sheets—Sheet 1.

C. J. BALTHASAR.

CAST IRON CONDUIT FOR STEAM OR HOT WATER HEATERS.

No. 520,747.

Patented May 29, 1894.

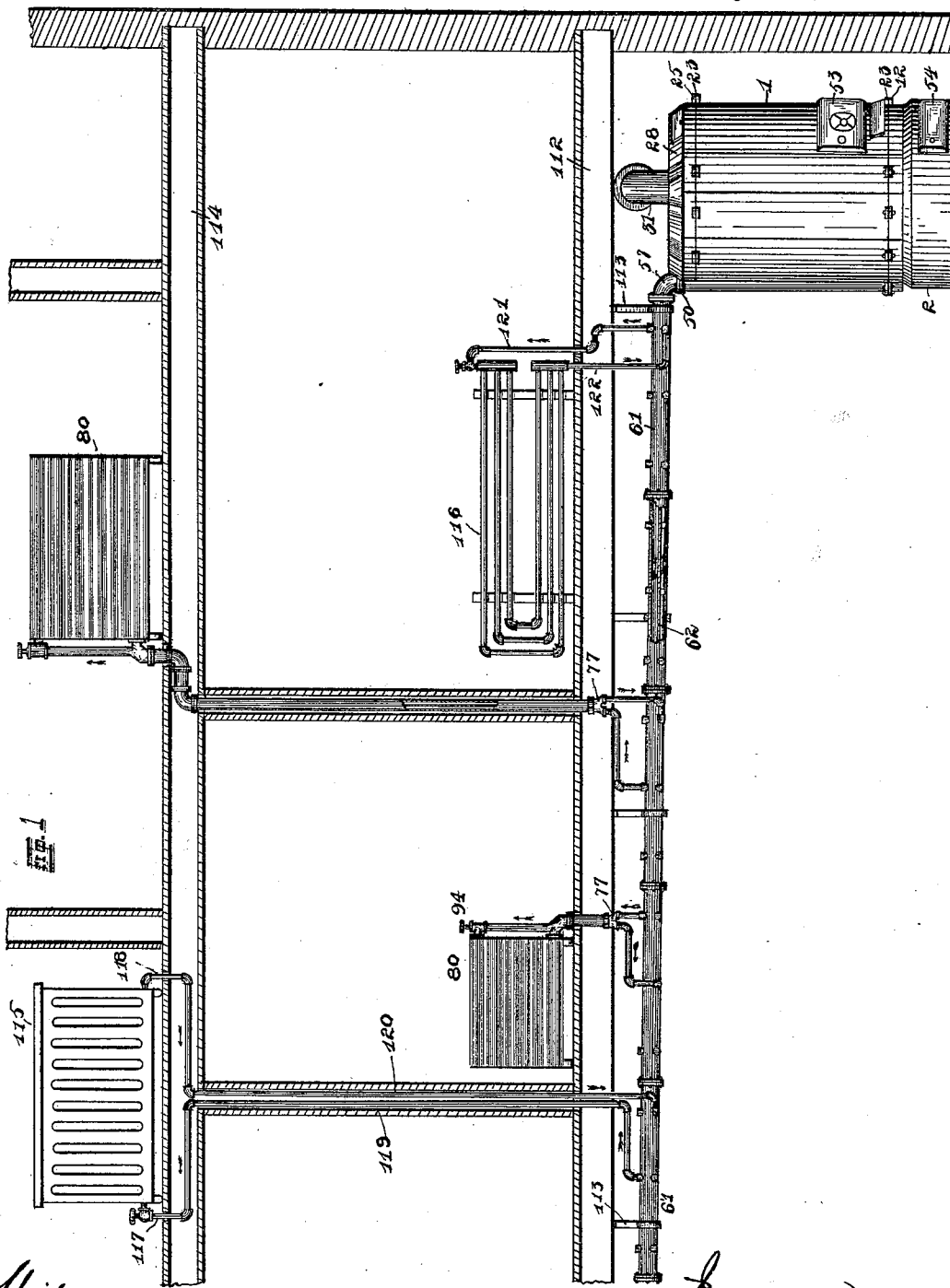

Witnesses,  
 Alfred A. [unclear]  
 Herbert H. Robinson;

Inventor,  
 Curt J. Balthasar  
 By Higdon & Higdon, Lawyers

(No Model.)

2 Sheets—Sheet 2.

C. J. BALTHASAR.

CAST IRON CONDUIT FOR STEAM OR HOT WATER HEATERS.

No. 520,747.

Patented May 29, 1894.

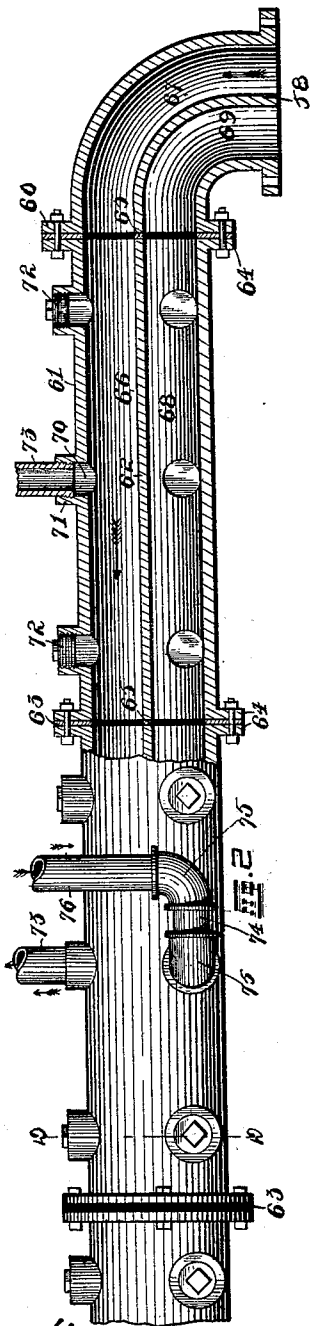

FIG. 1

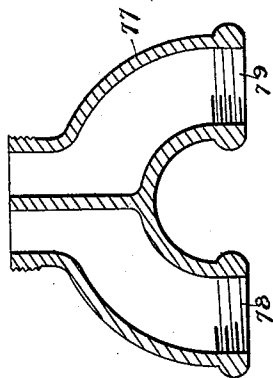

FIG. 4

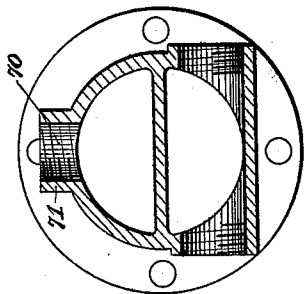

FIG. 3

Witnesses—

Alfred A. Eicher

Herbert Robinson

Inventor,  
C. J. Balthasar,

By Higdon & Higdon, Lawyers.

# UNITED STATES PATENT OFFICE.

CURT J. BALTHASAR, OF ST. LOUIS, MISSOURI, ASSIGNOR OF TWO-FIFTHS  
TO JOHN W. FRYER, OF SAME PLACE.

## CAST-IRON CONDUIT FOR STEAM OR HOT-WATER HEATERS.

SPECIFICATION forming part of Letters Patent No. 520,747, dated May 29, 1894.

Application filed February 13, 1893. Serial No. 462,184. (No model.)

*To all whom it may concern:*

Be it known that I, CURT J. BALTHASAR, of the city of St. Louis and State of Missouri, have invented certain new and useful Improvements in Cast-Iron Conduits for Steam or Hot-Water Heaters, of which the following is a full, clear, and exact description, reference being had to the accompanying drawings, forming a part hereof.

My invention relates to an improved cast iron conduit for steam or hot water heaters, and consists in the novel construction, combination and arrangement of parts hereinafter described and designated in the claims.

The object of my invention is to provide an improved single conduit of this class, which may be suspended bodily in the basement of a building without tapping or cutting holes therein, and at once connected to the steam and water spaces of a boiler and connected at various points in its outer surface with the several supply and return pipes of the radiators made use of, whereby passage for the steam or hot water to the radiators, and passage for the return therefrom will be located within a single shell, and thereby necessitate the making of but a single opening through walls for the passage of said conduit.

In the drawings: Figure 1 is a sectional side elevation of portions of a building having my invention applied therein, and illustrating the manner of connecting the radiators with the conduit and the conduit with a boiler or heater. Fig. 2 is a detail sectional side elevation of a portion of the conduit enlarged, and having parts broken away. Fig. 3 is a detail transverse section taken on the line D—D of Fig. 2. Fig. 4 is a detail sectional view of one of the connections shown in Fig. 1.

I desire to state that I do not claim herein the specific construction of a boiler or heater, which I have shown, nor do I claim the specific construction of the radiators herein shown.

I have only illustrated such parts in order to show the practical operation of my improved conduit.

1 indicates any suitable boiler or hot water heater, preferably located in the basement of a building upon a circular base 2, the upper

end of which is provided with projecting lugs 12, which are to be connected to corresponding lugs 23 formed on the lower end of the body of the heater or boiler, common bolts being used to connect said lugs. The boiler or heater 1, at a point adjacent its upper end, is provided with additional lugs 23 and 25, which are connected in a like manner by common bolts. The upper end of the boiler or heater is indicated by the numeral 28. A suitable smoke-pipe 31 connects the boiler or heater with the usual flue or chimney of a building. The boiler or heater 1 is preferably provided with a flanged connection 50, to which the adjacent end of the conduit is connected in the manner hereinafter stated. Said boiler or heater is provided with the usual firing door 53 and ash-pit door 54.

57 indicates an elbow preferably made of cast metal with the flange lower end secured in place upon the flanged connection 50 of the boiler, and the interior of which is divided longitudinally by a curved partition 58. The end of the elbow, which is opposite its lower end, is provided with a flange 60, and the flanges at each end of said elbow are perforated for the passage of common bolts.

61 indicates a conduit which is preferably made of cast iron in separate sections, which are placed end to end and united to form a single conduit of the desired length. The sections of the conduit are each constructed in a manner similar to the construction of the elbow 57, each having a central partition 62 located in a horizontal plane upon the interior of said sections and extending throughout their length, so that the end of said partition in the section adjacent said elbow will abut against the adjacent end of the partition 58 of said elbow and form a tight joint therewith, so that the adjacent ends of the said partitions of adjacent sections may abut and form tight joints, gaskets or other packing 63 being placed between the abutting portions of said parts. The gasket 63 is held between the flanges 64 upon the adjoining ends of the sections, and is provided with a horizontal center strip 65, which fits between the adjacent ends of the partitions 62 of the connected sections. By this construction there is formed

55

60

65

70

75

80

85

90

95

100

in the conduit an upper passage 66, which is continuous throughout the length of said conduit and connects at one end with a passage 67 in the elbow 57, and there is formed in said conduit beneath the partitions 62 another continuous passage 68, which extends parallel to the upper passage 66 and connects at one end with a passage 69 in said elbow. The passages 66 and 68 I will denominate as the upper and lower passages respectively. The passage 67 in the elbow 57 is to be connected with the steam space of the boiler, or with the hot water space of a hot water heater, while the passage 69 of said elbow is to be connected with the water space of the boiler or heater. The steam or hot water passes from the boiler or heater through the passage 67 in said elbow and into the upper passage 68 of said conduit; thence to the radiators in the manner hereinafter described, while the return water from said radiators is discharged into the lower passage 68 of said conduit; thence gravitates to the passage 69 of said elbow, and thence to the water space of the boiler or heater.

I desire to state that the conduit composed of sections in the manner above described, is to be suspended in the basement or other portion of a building adjacent the ceiling thereof, and in an inclined position with respect to said ceiling, so that the water of condensation, or the return water from the radiators may gravitate to said boiler or heater, as shown in Fig. 1, suitable hangers 113 being used for the purpose of thus suspending the said conduit.

Formed in the conduit 61, and in each section thereof at predetermined distances apart, both longitudinally and radially, are a series of openings 70 which are surrounded by interiorly screw-threaded nipples or flanges 71, so that there are a series of flanged and threaded openings formed in each of said sections at determinate distances apart, communicating some with the upper passage 66, and others with the lower passage 68. These openings are to be normally closed by common screw-plugs 72, which are to be removed when it is desired to connect a pipe 73 to said conduit at any portion of its length.

In fitting and applying my improved conduit, I make use of a number of supply pipes 73, which lead upward from the upper passage 66 of the conduit, and are arranged to carry the steam or hot water to the radiators and additional pipes 74, connected by means of elbows 75 to vertical return pipes 76 to carry the return water into the lower chamber 68 of said conduit.

As the nipples or flanges 71 are preferably cast integral with and in proper position upon the sections of the conduit, it is evident that it will be very easy to attach any suitable pipe to any one of the series of nipples by removing the screw-plug therefrom.

In Fig. 3 I have shown a section taken

through the line D—D of Fig. 2, which illustrates the relative location of the nipples 71 and the upper and lower passages of the conduit.

The various necessary connecting elbows and Y-joints are also constructed with a central partition wall, as shown in Figs. 2 and 4, Fig. 4 being illustrative of the Y-joint 77 having two orifices 78 and 79, one of which is arranged for the passage of steam or hot water, and the other of which is for the passage of the return water, this construction being used for connecting the pipes leading to the radiators and shown just above the conduit beneath the first floor of the building in Fig. 1. The radiators 80 may be of any common construction.

112 indicates a floor of a building immediately above the basement thereof, and 114 indicates a floor next above the floor 112.

115 indicates a common radiator of different construction from that of radiators 80, and 116 indicates a common radiator of still further modified construction. The radiator 115 is provided with a supply pipe 117, and an outlet or return pipe 118 connected by intermediate pipes 119 and 120 with the upper and lower passages 66 and 68 respectively in one of the sections of the main conduit 61. The riser 119, to which is connected the supply pipe 117 of the radiator 115, has its lower portion threaded into one of the nipples 71, and is thereby connected with the upper chamber 66 of the conduit, and in which the steam or hot water from the boiler only circulates, and the pipe 120 is connected to one of the nipples 71 of the lower chamber 68 of the same section of conduit, to which the pipe 119 is connected. The radiator 116 has a supply pipe 121 leading from the nipple 71 of the upper chamber 66 of a separate section of said conduit to the upper portion of said radiator, and a return pipe 122 has its upper end connected to the discharge end of said radiator, and its lower end connected to one of the nipples 71 in said section of the lower passage of said section.

The openings in the conduit and in the sections thereof, as well as the nipples 71 surrounding said openings, may be of various sizes, so that pipes of various sizes may be directly connected to the same section. This is clearly shown in Figs. 2 and 3, wherein the openings and the nipples of the upper portion of said sections are of smaller diameter than the openings and nipples of the lower portion of said sections.

An important advantage possessed by my improved conduit over steam or hot water mains at present known to the art, is a great saving in the weight of material and amount of labor and time used in constructing and placing the conduit. For instance, if the diameter of a conduit 61, constructed after my invention, is one and one half inches internal measurement, it will have the same car-

rying capacity as two separate conduits of cylindrical form, each having an internal diameter of one inch.

The passages in the improved conduit are each semi-circular in cross-section, and therefore only about one half of the surface of each is exposed to the low exterior temperature of the air which surrounds the conduit.

In the art of steam or hot water heating, it is believed that a supply and return main constructed to carry a heating media under high pressure and combined in one pipe of cylindrical form is a considerable advance in such art, for the reason that the two conduits or passages are thus placed so closely adjacent that the temperature of each is retained at a normally higher point than it would be if separate pipes were used for supply and return in the customary manner, thereby bringing about a great saving in fuel.

The return water from radiators in systems heretofore in use has had its temperature reduced from 25° to 35° below its initial temperature, but I have found by practical experiments with my invention that this decrease in temperature is reduced by at least one half by the use of my improved conduit, thereby obviating in a great measure the chilling of the water in the boiler by contact of the said return water.

I am aware that hot air pipes of various forms in cross-section have heretofore been made use of with parallel passages for conducting fluids of different temperatures in juxtaposition with a partition of heat conducting material between the two passages, so that the temperatures of the two media may become equalized, but in all of such pipes heretofore made use of there are no screw-threaded and flanged openings or nipples of various sizes by means of which steam or water pipes may be threaded into the main conduit at determinate points in its length, and I make no claim to the pipes so used prior to my invention.

What I claim is—

1. The combination, with a boiler having thereon discharge and return connections, of an elbow 57 having two separate passages 50 and attached to said boiler with one of said

passages in communication with the discharge-connection of said boiler, and the other one of said passages in communication with the return-connection of said boiler, a steam or hot water main divided into separate upper and lower passages and fixed in an inclined position, with its upper passage in communication with one of said passages of said elbow and with its lower passage in communication with the other one of said passages of said elbow, the ends of said upper and lower passages of said main being closed at a point remote from said boiler radiators, and a series of separate small pipes connected to the upper and lower spaces of said main and to said radiators.

2. As a new article of manufacture, a short cast section of a main for conducting steam or hot water under pressure, the same being an integral body of cast iron having its opposite terminals constructed to make a tight-joint with a similar contiguous section, and having its interior divided by an integral longitudinal partition, and a series of integral pipe-connections formed on said body and communicating with the interior of the same, a number on one side of said partition and a number on the opposite side thereof, substantially as and for the purpose herein specified.

3. In a steam or hot water system, the improved main, comprising a series of separate cast iron sections, each having end flanges and horizontal abutting partitions, gaskets placed between the abutting portions of said sections so as to form a tight-joint, and bolts for clamping together the adjacent flanges of said sections, said gaskets having a horizontal center-strip which fits between the adjacent ends of said partitions of the connected sections, in combination with a boiler having discharge and return connections to which the passages of said main are connected, substantially as herein specified.

In testimony whereof I affix my signature in presence of two witnesses.

CURT J. BALTHASAR.

Witnesses:

HERBERT S. ROBINSON,  
ALFRED H. EICKS.