

(12) INTERNATIONAL APPLICATION PUBLISHED UNDER THE PATENT COOPERATION TREATY (PCT)

(19) World Intellectual Property  
Organization

International Bureau

(43) International Publication Date  
22 November 2012 (22.11.2012)



(10) International Publication Number  
**WO 2012/156752 A1**

- (51) **International Patent Classification:**  
*E04G 5/02* (2006.01)      *E04B 1/343* (2006.01)
- (21) **International Application Number:**  
PCT/GB2012/051127
- (22) **International Filing Date:**  
18 May 2012 (18.05.2012)
- (25) **Filing Language:** English
- (26) **Publication Language:** English
- (30) **Priority Data:**  
1108402.7      19 May 2011 (19.05.2011)      GB
- (72) **Inventor; and**
- (71) **Applicant :** MARSHALL, Nicholas [GB/GB]; Unit 5, Albion Dockside, Hamover Place, Bristol BS1 6UT (GB).
- (74) **Agent:** GREAVES, Carol; Copa House, Station Road, Cheddar, Somerset BS27 3AH (GB).
- (81) **Designated States** (*unless otherwise indicated, for every kind of national protection available*): AE, AG, AL, AM, AO, AT, AU, AZ, BA, BB, BG, BH, BR, BW, BY, BZ,

CA, CH, CL, CN, CO, CR, CU, CZ, DE, DK, DM, DO, DZ, EC, EE, EG, ES, FI, GB, GD, GE, GH, GM, GT, HN, HR, HU, ID, IL, IN, IS, JP, KE, KG, KM, KN, KP, KR, KZ, LA, LC, LK, LR, LS, LT, LU, LY, MA, MD, ME, MG, MK, MN, MW, MX, MY, MZ, NA, NG, NI, NO, NZ, OM, PE, PG, PH, PL, PT, QA, RO, RS, RU, RW, SC, SD, SE, SG, SK, SL, SM, ST, SV, SY, TH, TJ, TM, TN, TR, TT, TZ, UA, UG, US, UZ, VC, VN, ZA, ZM, ZW.

(84) **Designated States** (*unless otherwise indicated, for every kind of regional protection available*): ARIPO (BW, GH, GM, KE, LR, LS, MW, MZ, NA, RW, SD, SL, SZ, TZ, UG, ZM, ZW), Eurasian (AM, AZ, BY, KG, KZ, RU, TJ, TM), European (AL, AT, BE, BG, CH, CY, CZ, DE, DK, EE, ES, FI, FR, GB, GR, HR, HU, IE, IS, IT, LT, LU, LV, MC, MK, MT, NL, NO, PL, PT, RO, RS, SE, SI, SK, SM, TR), OAPI (BF, BJ, CF, CG, CI, CM, GA, GN, GQ, GW, ML, MR, NE, SN, TD, TG).

**Published:**  
— with international search report (Art. 21(3))



WO 2012/156752 A1

(54) **Title:** FRAME SUPPORT

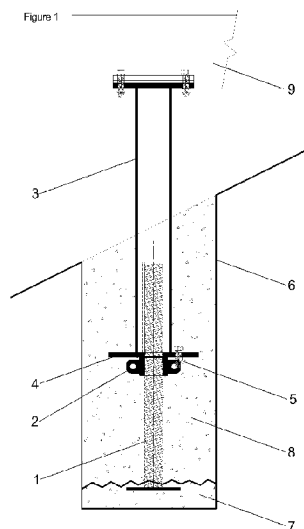

(57) **Abstract:** A frame support which can be used for inspection platforms, plant and equipment, prefabricated buildings and structures. The installation is carried out in three main stages, commencing with the fixing of a lightweight threaded base within a prepared hole. A load-bearing member is then attached to the base and adjusted by means of the thread and a threaded collar. Finally the threaded base, the threaded collar and a protrusion of the load-bearing member are substantially encased in concrete or a chemical compound to complete the installation.

Frame Support

This invention relates to the design of a frame support which can be used for inspection platforms, plant and equipment,  
5 prefabricated buildings and structures.

Construction and maintenance work close to hazardous areas such as motorway embankments and railway cuttings (for example bridge inspection and maintenance) frequently requires the installation  
10 of permanent or temporary platforms. These provide a safe working area with a level surface and protective barriers, away from the dangers of the adjacent hazard (i.e. the motorway or railway). However, motorway embankments and railway cuttings are invariably sloping with an irregular surface, making the  
15 erection of platforms difficult. A particular difficulty arises in the installation of large platforms where multiple supports must be accurately aligned in three dimensions.

Many types of frame support are currently in use such as driven  
20 posts and piles, screw-piles and supports embedded in concrete, but these all tend to suffer from inaccurate alignment. Depending on the requirements this may result in the need for subsequent adjustments with the associated costs and delays.

25 Driven posts or piles and screw-piles are generally installed with specialised plant which must be transported to the site and positioned adjacent or close to the point of installation, leading to costs and risks coupled with the need for suitable access.

30 The embedding of supports in concrete avoids the need for specialised plant but accuracy normally depends on the use of formwork or props. The formwork or props must be installed and subsequently either removed or left in place, adding complexity,  
35 cost and time to the overall installation process.

The frames associated with these types of support normally incorporate some scope for adjustment, but the limits are often exceeded on complex installations, particularly with regard to vertical adjustment on irregular, undulating or sloping sites.

5

All the types of frame support described above can be supplemented with load-bearing screw-jacks which are installed between the support and the frame for vertical adjustment, however these generally result in a significant increase in cost due to the size of thread and the related components required for load-bearing. They are also susceptible to tampering.

10

According to the present invention the installation is carried out in three main stages, commencing with the fixing of a lightweight threaded base within a prepared hole. A load-bearing member is then attached to the base and adjusted by means of the thread and a threaded collar. Finally the threaded base, the threaded collar and a protrusion of the load-bearing member are substantially encased in concrete or a chemical compound to complete the installation.

15

20

The installation can normally be completed with hand tools alone, avoiding the need to transport heavy plant to and from the site, with the associated costs and risks.

25

The threaded base can be smaller than a conventional screw-jack as it is not load-bearing (except for the weight of the load-bearing member and the threaded collar during installation), consequently this avoids a significant increase in cost while providing similar benefits to a load-bearing screw-jack. It also avoids the risk of tampering as it is substantially encased in concrete or a chemical compound on completion of the installation.

30

The benefits of the invention are likely to be greatest where there is a need for accurate alignment of multiple supports on

35

irregular, undulating or sloping sites with limited access.  
There is no requirement for heavy or specialised plant,  
formwork, props or load-bearing screw-jacks and consequently the  
installation can be completed without the associated complexity,  
5 risk, time and cost.

The present invention provides frame supports and a method of  
installing them which enables precise positioning in three  
dimensions, without the requirement of specialised equipment.

10

A first aspect of the present invention provides a frame support  
comprising:

- (i) a base, comprising an elongate member with a threaded  
external surface;
- 15 (ii) a threaded collar, dimensioned to engage with the threaded  
external surface of the elongate member; and
- (iii) a load-bearing member mountable on the threaded collar.

The load-bearing member may comprise a protrusion which is  
20 mountable on the threaded collar. The protrusion may be in  
direct or indirect contact or connection with the threaded  
collar. Similarly, the protrusion may be in direct or indirect  
contact or connection with the load-bearing member. For  
example, the protrusion may be separated from the threaded  
25 collar and/or the protrusion may be separated from the load-  
bearing member by a washer, spacer or the like. In one  
embodiment, the protrusion comprises a flange. The load-bearing  
member may comprise a supporting surface, to which a frame may  
be either directly or indirectly mounted.

30

The load-bearing member may comprise a hollow member with an  
internal clearance greater than the external diameter of the  
elongate member of the base; a protrusion at its lower end; and  
a supporting surface at its upper end. The hollow member could  
35 have, for example, a square, rectangular or circular cross-  
section.

The height of the threaded collar on the elongate member may be adjustable. The load-bearing member may engage with the threaded collar, such that rotation of the threaded collar about  
5 the elongate member of the base provides a means of adjusting the height of the load-bearing member.

Engaging features on the load-bearing member and the threaded collar may be provided so that rotation of the load-bearing  
10 member causes rotation of the threaded collar. An engagement feature on the load-bearing member may comprise a bolt.

The threaded collar may comprise a nut. The threaded collar may be integral with the load-bearing member and/or protrusion.  
15 Alternatively, the threaded collar may be separate to the load-bearing member and/or protrusion. Alternatively, the protrusion and the threaded collar may be joined, for example, by welding.

The base may further comprise one or more apertures through  
20 which fasteners can be inserted to fix the base to the ground. The frame support may further comprise fasteners, for example pins or bolts.

According to a preferred aspect of the present invention, there  
25 is provided a frame support comprising:

- (i) a base, comprising an elongate member with a threaded external surface;
- (ii) a threaded collar, dimensioned to engage with the threaded external surface of the elongate member; and
- 30 (iii) a load-bearing member mountable on the threaded collar, said load-bearing member comprising a protrusion, wherein the load-bearing member engages with the threaded collar, such that rotation of the load-bearing member causes rotation of the threaded collar about the elongate member of the  
35 base providing a means of adjusting the height of the load-bearing member, and wherein in use the base, the threaded collar

and the protrusion of the load-bearing member are substantially encased.

It is to be understood that in its assembled form the component parts of the frame support are in operable connection to one another, meaning that any one or all of the components need not be in direct contact. For example, the load-bearing member may comprise a supporting surface, to which a frame may be either directly or indirectly mounted. Similarly, the protrusion may be separated from the threaded collar, for example, by a washer, spacer or the like. Similarly, the protrusion may be separated from the load-bearing member, for example, by a washer, spacer or the like.

A second aspect of the present invention provides a frame assembly comprising one or more frame supports according to any one of claims 1 to 15 and a frame supported on the one or more frame supports. A single frame support may be sufficient to support a small frame, whereas at least three, four or more supports may be required for larger frames.

The weight of the frame is taken through the load-bearing member, rather than the base.

The frame may be secured to the one or more frame supports by welding or by bolts or other fasteners.

A third aspect of the present invention provides a method of installing a frame support comprising the steps of:

- (i) mounting a base within a prepared hole, wherein the base comprises an elongate member with a threaded external surface;
- (ii) securing the base in the hole;
- (iii) fitting a load-bearing member over the threaded base;

- (iv) adjusting its height by means of a threaded collar, dimensioned to engage with the threaded external surface of the elongate member; and
- (v) filling the hole to at least substantially encase the base, the threaded collar and the bottom of the load-bearing member.

This method allows the frame support to be easily adjusted in three dimensions. The base may be correctly positioned horizontally within the hole. When the base has been secured, adjustment of the threaded collar allows vertical adjustment.

The bottom of the load-bearing member may comprise a protrusion, for example a flange. The protrusion may be in direct or indirect contact or connection with the threaded collar.

Similarly, the protrusion may be in direct or indirect contact or connection with the load-bearing member. For example, the protrusion may be separated from the threaded collar and/or the protrusion may be separated from the load-bearing member by a washer, spacer or the like. Substantially encasing the protrusion enables it to act as an anchor. Once encased, the protrusion is thus load-bearing of the frame mounted on the support.

The step of securing the base may comprise partially embedding it in concrete or a chemical compound. The concrete may comprise dry-mixed or wet-mixed concrete. Dry-mixed concrete provides the benefits of convenience and speed. The chemical compound is preferably able to set sufficiently to support the base in position. Alternatively, the step of securing the base comprises fastening it to the bottom of the hole using fasteners, such as pins or bolts.

The step of filling the hole to at least substantially encase the base, the threaded collar and the bottom of the load-bearing member may comprise substantially filling the hole with concrete

or a chemical compound. The concrete may comprise dry-mixed or wet-mixed concrete. The chemical compound is preferably able to support the load-bearing member in position once it reaches full strength.

5

The method may comprise the step of directly or indirectly attaching a frame to the exposed portion of the load-bearing member.

- 10 The frame support and method of installing it are particularly suitable for supporting platforms on irregular, sloping or undulating ground, for example inspection platforms adjacent to motorways and railways and for platforms adjacent to reservoirs used for water sampling. The apparatus and method are also
- 15 suitable for supporting plant and equipment, prefabricated buildings and structures.

According to a preferred aspect of the present invention, there is provided a method of installing a frame support comprising

20 the steps of:

- (i) mounting a base within a prepared hole, wherein the base comprises an elongate member with a threaded external surface;
- (ii) securing the base in the hole;
- 25 (iii) fitting a load-bearing member over the threaded base, wherein the load-bearing member comprises a protrusion;
- (iv) adjusting its height by means of a threaded collar, dimensioned to engage with the threaded external
- 30 surface of the elongate member; and
- (v) filling the hole to at least substantially encase the base, the threaded collar and the protrusion of the load-bearing member.

Preferred features of the second and third aspects of the invention may be as described above in connection with the first aspect.

5 Throughout the description and claims of this specification, the words "comprise" and "contain" and variations of the words, for example "comprising" and "comprises", mean "including but not limited to", and do not exclude other moieties, additives, components, integers or steps.

10

Throughout the description and claims of this specification, the singular encompasses the plural unless the context otherwise requires. In particular, where the indefinite article is used, the specification is to be understood as contemplating plurality as well as singularity, unless the context requires otherwise.

15

Other features of the present invention will become apparent from the following example. Generally speaking the invention extends to any novel one, or any novel combination, of the features disclosed in this specification (including any accompanying claims and drawings). Thus features, integers, characteristics or compounds described in conjunction with a particular aspect, embodiment or example of the invention are to be understood to be applicable to any other aspect, embodiment or example described herein unless incompatible therewith.

20

25

Moreover unless stated otherwise, any feature disclosed herein may be replaced by an alternative feature serving the same or a similar purpose.

30

The present invention will now be described by way of example only and with reference to the accompanying illustrative drawings, wherein:

35

Figure 1 is a cross section through the assembled frame support of the present invention; and

Figure 2 illustrates the method of installing the frame support.

Figure 1 shows the assembled frame support consisting of a base comprising an elongate member with a threaded external surface 1, a threaded collar 2 and a load-bearing member 3 which  
5 incorporates a flange 4. A bolt 5 attached to the flange 4 engages with the threaded collar 2 to provide a means of adjusting the height of the load-bearing member 3 when it is rotated. As the bolt 5 engages with a feature on the threaded collar, rotation of the load-bearing member causes rotation of  
10 the threaded collar. Alternative engaging features on the load-bearing member and threaded collar may be used or the load-bearing member and threaded collar may be joined, for example by welding.

15 The frame support is located in a prepared hole 6 which has been filled with dry-mixed concrete in two stages 7 then 8 (see Figure 2). Following assembly the frame support has been attached to a frame 9.

20 Figure 2 shows a method of installing a pair of frame supports consisting of the following steps shown in the sequence A to G:

- A: Preparing holes 6 for the frame supports in the required positions;  
25 B: Placing a layer of concrete 7 in the bottom of each hole;
- C: Positioning a base 1 and threaded collar 2 in the bottom of each hole with the base embedded in the concrete;  
30 D: Fitting a load-bearing member 3 to each base when the concrete has partially cured and gained sufficient strength to prevent movement;
- 35 E: Adjusting the height of each load-bearing member by means of rotation of the threaded collar on the base, rotating the load-

bearing member so that the threaded collar engages with a bolt 5 attached to the flange 4;

F: Substantially, encasing the base, the threaded collar and the  
5 flange on each load-bearing member in concrete 8; and

G: Attaching a frame 9 to each load-bearing member when the concrete has partially cured and gained sufficient strength to prevent movement.

**Claims**

1. A frame support comprising:
  - 5 (i) a base, comprising an elongate member with a threaded external surface;
  - (ii) a threaded collar, dimensioned to engage with the threaded external surface of the elongate member; and
  - (iii) a load-bearing member mountable on the threaded collar, said load-bearing member comprising a protrusion,
- 10 wherein the load-bearing member engages with the threaded collar, such that rotation of the load-bearing member causes rotation of the threaded collar about the elongate member of the base providing a means of adjusting the height of the load-bearing member, and wherein in use the base, the threaded collar
- 15 and the protrusion of the load-bearing member are substantially encased.
  
2. A frame support according to claim 1, wherein the protrusion is mountable on the threaded collar.
- 20
3. A frame support according to claim 1 or 2, wherein the protrusion is separated from the threaded collar by a washer, spacer or the like.
  
- 25 4. A frame support according to claim 1 or 2, wherein the protrusion and the threaded collar are in direct contact or connection.
  
5. A frame support according to any of claims 1 to 4, wherein
- 30 the protrusion and the load-bearing member are in direct or indirect contact or connection.
  
6. A frame support according to any of claims 1 to 5, wherein the protrusion comprises a flange.

7. A frame support according to any one of the preceding claims, wherein the load-bearing member comprises a supporting surface, to which a frame may be directly or indirectly mounted.
- 5 8. A frame support according to any one of the preceding claims, wherein the load-bearing member comprises a hollow member with an internal clearance greater than the external diameter of the elongate member of the base; a protrusion at its lower end and a supporting surface at its upper end.
- 10 9. A frame support according to any one of the preceding claims, wherein the height of the threaded collar on the elongate member is adjustable.
- 15 10. A frame support according to any one of the preceding claims, wherein the threaded collar comprises a nut.
- 20 11. A frame support according to any one of the preceding claims, wherein the threaded collar is integral with the load-bearing member and/or protrusion.
- 25 12. A frame support according to any one of claims 1 to 10, wherein the threaded collar is not integral with the load-bearing member and/or protrusion.
- 30 13. A frame support according to any one of the preceding claims, wherein the base further comprises one or more apertures through which fasteners can be inserted to fix the base to the ground.
- 35 14. A frame support according to claim 13, further comprising fasteners.
15. A frame support according to claim 14, wherein the fasteners are selected from the group of pins and bolts.

16. A frame assembly comprising one or more frame supports according to any one of claims 1 to 15 and a frame supported on the one or more frame supports.
- 5 17. A frame assembly according to claim 16, wherein the weight of the platform is supported by the load-bearing members of the frame supports.
18. A frame assembly according to claim 16 or 17, wherein the  
10 frame is secured to said one or more frame supports by welding or by bolts or other fasteners.
19. A method of installing a frame support comprising the steps of:
- 15 (i) mounting a base within a prepared hole, wherein the base comprises an elongate member with a threaded external surface;
- (ii) securing the base in the hole;
- (iii) fitting a load-bearing member over the threaded base,  
20 wherein the load-bearing member comprises a protrusion;
- (iv) adjusting the height of the load-bearing member by means of a threaded collar, dimensioned to engage with the threaded external surface of the elongate  
25 member; and
- (v) filling the hole to at least substantially encase the base, the threaded collar and the protrusion of the load-bearing member.
- 30 20. A method according claim 19, wherein the step of securing the base comprises partially embedding it in concrete or a chemical compound.
21. A method according to claim 20, wherein the concrete  
35 comprises dry-mixed concrete.

22. A method according to claim 20, wherein the concrete comprises wet-mixed concrete.
23. A method according to claim 19, wherein the step of  
5 securing the base comprises fastening it to the bottom of the hole using fasteners.
24. A method according to claim 23, wherein the fasteners comprise pins or bolts.
- 10 25. A method according to claim 19, wherein the protrusion is separated from the threaded collar by a washer, spacer or the like.
- 15 26. A method according to claim 19, wherein the protrusion is in direct contact or connection with the threaded collar.
- 20 27. A method according to claim 19, wherein the protrusion and the load-bearing member are in direct or indirect contact or connection.
28. A method according to any one of claims 19, 25, 26 or 27 wherein the protrusion comprises a flange.
- 25 29. A method according to claim 19, wherein the hole is substantially filled with concrete or a chemical compound.
- 30 30. A method according to claim 29, wherein the concrete comprises dry-mixed concrete.
31. A method according to claim 29, wherein the concrete comprises wet-mixed concrete.
- 35 32. A method according to any one of claims 19 to 31, comprising the step of directly or indirectly attaching a frame to the exposed portion of the load-bearing member.

33. A frame support substantially as herein described with reference to the accompanying illustrative drawings.

5 34. A frame assembly substantially as herein described with reference to the accompanying illustrative drawings.

35. A method of installing a frame support substantially as herein described with reference to the accompanying illustrative  
10 drawings.

1/2

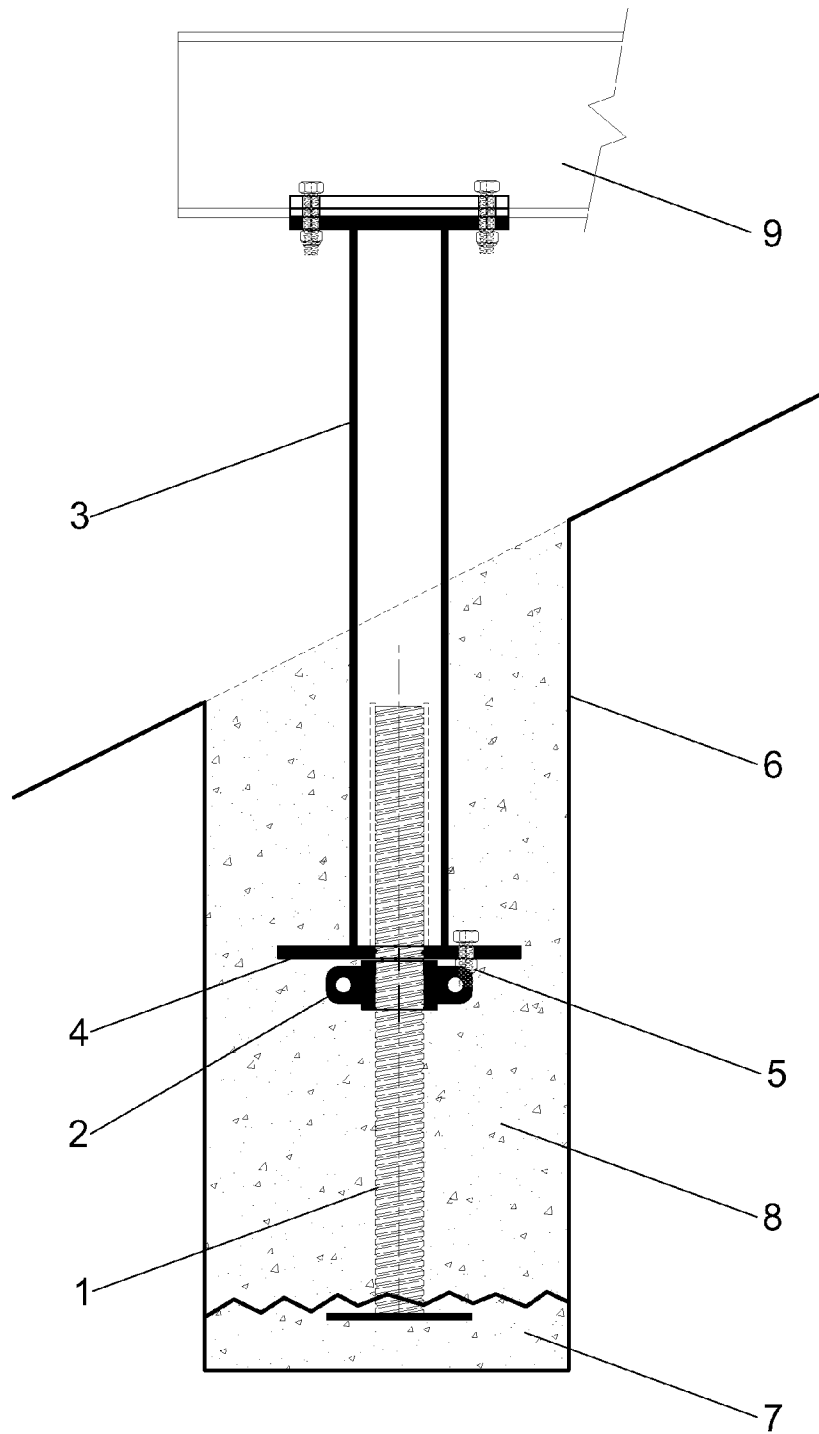

Figure 1

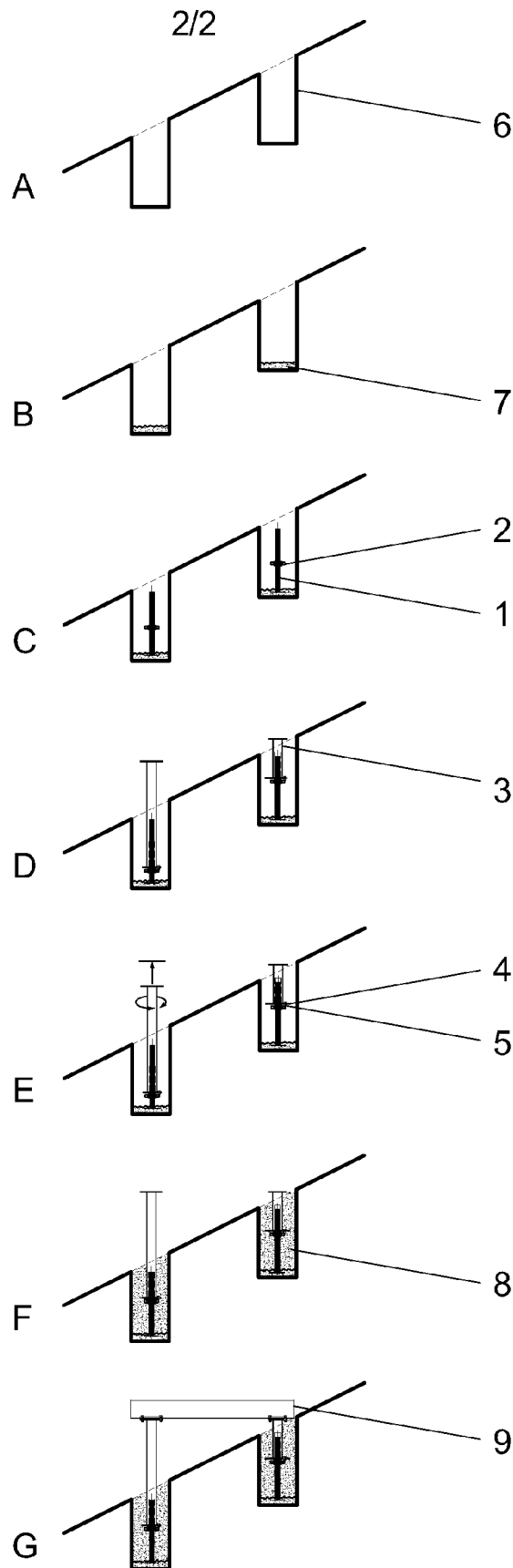

Figure 2