

(19) **DANMARK**

(10) **DK/EP 3114048 T3**



Patent- og  
Varemærkestyrelsen

(12) **Oversættelse af  
europæisk patentskrift**

- 
- (51) Int.Cl.: **B 65 D 85/804 (2006.01)**
- (45) Oversættelsen bekendtgjort den: **2019-07-29**
- (80) Dato for Den Europæiske Patentmyndigheds bekendtgørelse om meddelelse af patentet: **2019-04-24**
- (86) Europæisk ansøgning nr.: **16744560.0**
- (86) Europæisk indleveringsdag: **2016-05-13**
- (87) Den europæiske ansøgnings publiceringsdag: **2017-01-11**
- (86) International ansøgning nr.: **NL2016050349**
- (87) Internationalt publikationsnr.: **WO2016186495**
- (30) Prioritet: **2015-05-15 WO PCT/NL2015/050352** **2015-05-15 WO PCT/NL2015/000018**  
**2015-05-15 WO PCT/NL2015/050349** **2015-09-03 WO PCT/NL2015/050611**
- (84) Designerede stater: **AL AT BE BG CH CY CZ DE DK EE ES FI FR GB GR HR HU IE IS IT LI LT LU LV MC MK MT NL NO PL PT RO RS SE SI SK SM TR**
- (73) Patenthaver: **Koninklijke Douwe Egberts B.V., Vleutensevaart 35, 3532 AD Utrecht, Holland**
- (72) Opfinder: **DIJKSTRA, Hielke, c/o Vleutensevaart 35, 3532 AD Utrecht, Holland**  
**GROOTHORNTÉ, Arend Hendrik, c/o Vleutensevaart 35, 3532 AD Utrecht, Holland**  
**VAN GAASBEEK, Erik Pieter, c/o Vleutensevaart 35, 3532 AD Utrecht, Holland**  
**OTTENSCHOT, Marc Henrikus Joseph, c/o Vleutensevaart 35, 3532 AD Utrecht, Holland**  
**Kamerbeek, Ralf, c/o Vleutensevaart 35, 3532 AD Utrecht, Holland**  
**EIJSACKERS, Armin Sjoerd, c/o Vleutensevaart 35, 3532 AD Utrecht, Holland**  
**Flamand, John Henri, c/o Vleutensevaart 35, 3532 AD Utrecht, Holland**  
**HALLIDAY, Andrew Michael, c/o Vleutensevaart 35, 3532 AD Utrecht, Holland**  
**HANSEN, Nicholas Andrew, c/o Vleutensevaart 35, 3532 AD Utrecht, Holland**
- (74) Fuldmægtig i Danmark: **NORDIC PATENT SERVICE A/S, Bredgade 30, 1260 København K, Danmark**
- (54) Benævnelse: **KAPSEL, SYSTEM TIL TILBEREDNING AF EN DRIKKELIG DRIKKEVARE UD FRA EN SÅDAN KAPSEL OG ANVENDELSE AF EN SÅDAN KAPSEL I EN DRIKKEVARETILBEREDNINGSINDRETNING**
- (56) Fremdragne publikationer:  
**WO-A1-2006/045536**  
**WO-A1-2007/122206**  
**WO-A1-2014/118812**  
**WO-A1-2014/184652**  
**WO-A1-2014/184653**  
**WO-A2-2014/012779**



## DESCRIPTION

**[0001]** The invention relates to a capsule containing a substance for the preparation of a potable beverage by extracting and/or dissolving the substance by means of supplying a fluid under pressure into the capsule, wherein the capsule comprises an aluminum capsule body having a central capsule body axis, the aluminum capsule body being provided with a bottom, a side wall and an outwardly extending flange, the capsule further comprising an aluminum cover attached to the outwardly extending flange, the cover hermetically closing the capsule, wherein the capsule further comprises a sealing member at the outwardly extending flange for providing a fluid sealing contact with an enclosing member of a beverage preparation device if the capsule is positioned in the enclosing member of the beverage preparation device and the enclosing member is closed by means of a closing member of the beverage preparation device, such as an extraction plate of the beverage preparation device, such that the outwardly extending flange of the capsule and at least a portion of the sealing member of the capsule are sealingly engaged between the enclosing member and the closing member of the beverage preparation device, wherein the enclosing member of the beverage preparation device comprises an annular element having a central annular element axis and a free contact end, the free contact end of the annular element optionally being provided with a plurality of radially extending open grooves.

**[0002]** The invention also relates to a system for preparing a potable beverage from a capsule using a fluid supplied under pressure into the capsule comprising:

a beverage preparation device comprising an enclosing member for receiving the capsule, wherein the enclosing member comprises fluid injection means for supplying fluid under pressure into the capsule, wherein the beverage preparation device further comprises a closing member, such as an extraction plate, for closing the enclosing member of the beverage preparation device, wherein the enclosing member of the beverage preparation device further comprises an annular element having a central annular element axis and a free contact end, the free contact end of the annular element optionally being provided with a plurality of radially extending open grooves;

a capsule containing a substance for the preparation of a potable beverage by extracting and/or dissolving the substance by means of the fluid supplied under pressure into the capsule by the fluid injection means of the beverage preparation device, wherein the capsule comprises an aluminum capsule body having a central capsule body axis, the aluminum capsule body being provided with a bottom, a side wall and an outwardly extending flange, the capsule further comprising an aluminum cover attached to the outwardly extending flange, the cover hermetically closing the capsule, wherein the capsule further comprises a sealing member at the outwardly extending flange for providing a fluid sealing contact with the enclosing member of the beverage preparation device if the capsule is positioned in the enclosing member of the beverage preparation device and the enclosing member is closed by means of the closing member of the beverage preparation device, such that the outwardly extending flange of the capsule and at least a portion of the sealing member of the capsule are

sealingly engaged between the enclosing member and the closing member of the beverage preparation device.

**[0003]** Furthermore the invention relates to the use of a capsule in a beverage preparation device comprising an enclosing member for receiving the capsule, wherein the enclosing member comprises fluid injection means for supplying fluid under pressure into the capsule, wherein the beverage preparation device further comprises a closing member, such as an extraction plate, for closing the enclosing member of the beverage preparation device, wherein the enclosing member of the beverage preparation device further comprises an annular element having a central annular element axis and a free contact end, the free contact end of the annular element optionally being provided with a plurality of radially extending open grooves; wherein the capsule contains a substance for the preparation of a potable beverage by extracting and/or dissolving the substance by means of the fluid supplied under pressure into the capsule by the fluid injection means of the beverage preparation device, wherein the capsule comprises an aluminum capsule body having a central capsule body axis, the aluminum capsule body being provided with a bottom, a side wall and an outwardly extending flange, the capsule further comprising an aluminum cover attached to the outwardly extending flange, the cover hermetically closing the capsule, wherein the capsule further comprises a sealing member at the outwardly extending flange for providing a fluid sealing contact with the enclosing member of the beverage preparation device if the capsule is positioned in the enclosing member of the beverage preparation device and the enclosing member is closed by means of the closing member of the beverage preparation device, such that the outwardly extending flange of the capsule and at least a portion of the sealing member of the capsule are sealingly engaged between the enclosing member and the closing member of the beverage preparation device.

**[0004]** Such a capsule, system and use are known from EP-B-1 700 548 and from WO 2014/184653 A1. In the known system the capsule is provided with a sealing member having the shape of a step, i.e. a sudden increase of the diameter of the side wall of the capsule, and the enclosing member of this known system has a sealing surface acting on the sealing member to provide deflection of the sealing member, the sealing surface being inclined so that the deflection of the sealing member is an inwards and downwards deformation of the step. Furthermore in the known system the enclosing member comprises a capsule holder and a manually operated or an automatic mechanism for relative displacement of the enclosing member and the capsule holder. The manually operated or an automatic mechanism applies a force on the sealing member of the capsule when the enclosing member closes on the capsule holder. This force should ensure the fluid tight seal between the enclosing member and the capsule. Because the manually operated or an automatic mechanism is arranged to be moved relative to the base, the sealing capabilities of the system can depend on the pressure of the fluid injected by the fluid injection means. If the pressure of the fluid increases, the force between the sealing member of the capsule and the free end of the enclosing member increases too and thereby the force between the sealing member of the capsule and the free

end of the enclosing member increases also. The sealing member of the capsule must be arranged such that upon reaching the maximum fluid pressure in the enclosing member the sealing member should still provide a fluid sealing contact between the enclosing member and the capsule. However, the sealing member must also be arranged such that prior to, or at the start of, brewing when the pressure of the fluid in the enclosing member outside the capsule is relatively low, the sealing member also provides a fluid sealing contact between the enclosing member and the capsule. If at the start of brewing, there would not exist a fluid sealing contact between the capsule and the enclosing member, leakage will occur. However, if leakage occurs there is a real chance that the pressure in the enclosing member and outside the capsule will not sufficiently increase for increasing the force on the sealing member by means of the free end of the enclosing member if the manually operated or an automatic mechanism moves the enclosing member towards the capsule holder. Only if there is a sufficient initial sealing, the pressure in the enclosing member will increase whereby also the force of the free end of the enclosing member acting on the sealing member of the capsule will increase for providing a sufficient fluid sealing contact at also the increased fluid pressure. Moreover, this increased fluid pressure outside the capsule also provides an increased fluid pressure inside the capsule which is essential if the capsule is provided with a cover which is arranged to tear open on relief members of the capsule holder (also called an extraction plate) of the beverage preparation device under the influence of fluid pressure in the capsule.

**[0005]** It follows from the above that the sealing member is a member which is very critical in design. It should be able to provide a fluid sealing contact between the enclosing member and the capsule at a relatively low fluid pressure if only a relatively small force is applied on the sealing member by means of the free end of the enclosing member but it should also provide a fluid sealing contact at a much higher fluid pressure in the enclosing member outside the capsule if a higher force is applied by means of the free end of the enclosing member to the sealing member of the capsule. In particular when the free contact end of the enclosing member is provided with radially extending open grooves which act as air inlet passage once the force between the enclosing member and the capsule holder is released so that it is easier for a user to take out the capsule, the sealing member must also be able to 'close' the radially extending open grooves to provide an effective seal.

**[0006]** It is an object of the invention to provide an alternative sealing member which is relatively easy to manufacture, which is environmentally friendly if the capsule is disposed of after use and/or which provides a satisfactory sealing both at a relatively low fluid pressure if only a relatively small force is applied on the sealing member by means of the free end of the enclosing member (sometimes also called initial seal) and at a much higher fluid pressure if a higher force is applied (e.g. during brewing) by means of the free end of the enclosing member to the sealing member of the capsule, even in case of an enclosing member of which the free contact end is provided with radially extending open grooves.

**[0007]** The invention has also as an object to provide an alternative system for preparing a potable beverage from a capsule and to provide an alternative use of a capsule in a beverage preparation device.

**[0008]** In accordance with the invention there is provided a capsule according to claim 1. Since the sealing member is integral with the outwardly extending flange and comprises at least one projection of which the top exerts a radial force on the free contact end of the annular element if the capsule is positioned in the enclosing member of the beverage preparation device and the enclosing member is closed by means of a closing member of the beverage preparation device a satisfactory sealing can be obtained. Such a sealing member is relatively easy to manufacture. Furthermore the capsule can provide a satisfactory sealing with the free contact end provided with radially extending open grooves. In addition the sealing facilitates positioning of the capsule inside the beverage preparation device.

**[0009]** In this application the existence of a fluid sealing contact means that 0-6%, preferably 0-4%, more preferably 0-2.5% of the total fluid supplied to the enclosing member for preparing the beverage may leak away due to leakage between the free contact end and the sealing member of the capsule.

**[0010]** The invention is in particular advantageous when in an embodiment of a capsule the capsule contains an extractable product as substance for the preparation of a potable beverage, the extractable product preferably being 5-20 grams, preferably 5-10 grams, more preferably 5-7 grams of an extractable product, such as roasted and ground coffee.

**[0011]** In an embodiment of a capsule according to the invention which is in particular easy to manufacture the outer diameter of the outwardly extending flange of the capsule is larger than the diameter of the bottom of the capsule. Preferably, the outer diameter of the outwardly extending flange is approximately 37.1 mm and the diameter of the bottom of the capsule is about 23.3 mm.

**[0012]** The invention is in particular advantageous when in an embodiment of a capsule the thickness of the aluminum capsule body is such that it is deformed easily if the capsule is positioned in the enclosing member of the beverage preparation device and the enclosing member is closed by means of a closing member of the beverage preparation device, preferably the thickness of the aluminum capsule body is 20 to 200 micrometer, preferably 100 micrometer.

**[0013]** The invention is in particular advantageous when in an embodiment of a capsule the thickness of the aluminum cover is 15 to 65 micrometer, preferably 30-45 micrometer and more preferably 39 micrometer.

**[0014]** In an embodiment of a capsule according to the invention the wall thickness of the aluminum cover is smaller than the wall thickness of the aluminum capsule body.

**[0015]** In a further embodiment of a capsule according to the invention the aluminum cover is arranged to tear open on a closing member of the beverage preparation device, such as an extraction plate of the beverage preparation device under the influence of fluid pressure in the

capsule.

**[0016]** In an embodiment of a capsule according to the invention which is in particular easy to manufacture the side wall of the aluminum capsule body has a free end opposite the bottom, the outwardly extending flange extending from the free end of the side wall in a direction at least substantially transverse to the central capsule body axis. Preferably, the outwardly extending flange comprises a curled outer edge, which is beneficial in obtaining for a satisfactory sealing with the free contact end provided with radially extending open grooves. The radius about the central capsule body axis of an inner edge of the curled outer edge of the outwardly extending flange is preferably at least 32 mm, so that clearance from the annular end surface of the enclosure member is ensured. It is then preferred that the sealing member is positioned between the free end of the side wall of the aluminum capsule body and an inner edge of the curled outer edge of the outwardly extending flange to obtain a still further satisfactory sealing.

**[0017]** To ensure that the curled outer edge does not interfere with operation of a wide variety of commercially available and future beverage preparation apparatuses, the curled outer edge of the outwardly extending flange has a largest dimension of about 1.2 millimeter.

**[0018]** The invention is in particular beneficial for capsules of which the inner diameter of the free end of the side wall of the aluminum capsule body is about 29.5 mm. The distance between the free end of the side wall of the aluminum capsule body and an outermost edge of the outwardly extending flange can be about 3.8 millimeter. The preferred height of the aluminum capsule body is about 28.4 mm.

**[0019]** In an embodiment of a capsule according to the invention which after use is easier for a user to take out of a beverage preparation device the aluminum capsule body is truncated, wherein preferably the side wall of the aluminum capsule body encloses an angle with a line transverse to the central capsule body axis of about 97.5°.

**[0020]** In an advantageous embodiment of a capsule according to the invention the bottom of the aluminum capsule body has a largest inner diameter of about 23.3 mm. It is preferred that the bottom of the aluminum capsule body is truncated, preferably having a bottom height of about 4.0 mm and that the bottom further has a generally flat central portion opposite the cover having a diameter of about 8.3 mm.

**[0021]** In practically all cases a satisfactory seal can be obtained in an embodiment of a capsule according to the invention in which the height of the sealing member portion to be contacted first by the free end of the enclosure member when the enclosure member is closed is at least about 0.1 mm, more preferably at least 0.2 mm and most preferably at least 0.8 mm and at most 3 mm, more preferably at most 2 mm and most preferably at most 1.2 mm.

**[0022]** In a preferred embodiment of a capsule according to the invention the capsule comprises an inner surface, and wherein on the inner surface of at least the side wall of the

capsule an inner coating is provided. In particular when the capsule is manufactured by deep drawing the inner coating facilitates the deep drawing process. In case the aluminum cover of the capsule is attached to the outwardly extending flange by means of a sealing lacquer it is then in particular advantageous when the inner coating being composed of the same material as the sealing lacquer. In dependence of the inner coating used it is preferred that the sealing member is free from an inner coating in order to prevent crumbling off of the inner coating from the sealing member.

**[0023]** In a further embodiment of a capsule according to the invention the capsule comprises an outer surface, wherein on the outer surface of the capsule a color lacquer is provided. In order to facilitate in deep drawing it is preferred to provide on an outer surface of the color lacquer an outer coating. In dependence of the color lacquer and outer coating used it is preferred that the sealing member is free from a color lacquer (and consequently the outer coating) in order to prevent crumbling off of the color lacquer/outer coating from the sealing member.

**[0024]** In a still further embodiment of a capsule according to the invention the at least one projection comprises a projection side wall which is inclined with regard to the outwardly extending flange of the aluminum capsule body, the projection side wall being configured such that it is deformed easily if the capsule is positioned in the enclosing member of the beverage preparation device and the enclosing member is closed by means of a closing member of the beverage preparation device. This improves the force exerted on the free contact end and thus improves the sealing. It is then preferred when the distance between the projection and the side wall of the aluminum capsule body is such that the free contact end of the annular element is contacted by the projection and the side wall of the aluminum capsule body if the capsule is positioned in the enclosing member of the beverage preparation device and the enclosing member is closed by means of a closing member of the beverage preparation device.

**[0025]** The sealing member can comprises two spaced projections, each projecting from the outwardly extending flange and a plateau between the two projections, wherein the distance between the two projections is such that the free contact end of the annular element is squeezed between converging surfaces of the two projections if the capsule is positioned in the enclosing member of the beverage preparation device and the enclosing member is closed by means of a closing member of the beverage preparation device. It is then preferred when the distance between the two projections is such that the free contact end of the annular element is contacted by the two projections if the capsule is positioned in the enclosing member of the beverage preparation device and the enclosing member is closed by means of a closing member of the beverage preparation device. In particular a satisfactory seal can be obtained when the two spaced projections and the plateau are arranged such that the free contact end of the annular element is contacted by the plateau if the capsule is positioned in the enclosing member of the beverage preparation device and the enclosing member is closed by means of a closing member of the beverage preparation device. The capsule can preferably comprise a bearing for the enclosing member of the beverage preparation device if the capsule is

positioned in the enclosing member of the beverage preparation device and the enclosing member is closed by means of a closing member of the beverage preparation device, the bearing enclosing at least a portion of the free contact end of the annular element and the bearing being formed by the two projections and the plateau there between.

**[0026]** The plateau can be substantially flat or can comprise a curved portion. In particular advantageous is the embodiment of a capsule according to the invention in which the plateau is V-shaped. In this manner the free contact end of the annular member is squeezed between the two projections providing a satisfactory seal.

**[0027]** To achieve sequential low and high pressure sealings against inner and outer circumferential surface portions of the free end of the enclosing member, a first one of the two projections may project further from a base portion of the outwardly extending flange, to which base portion the cover is attached, than a second one of the two projections.

**[0028]** Additionally or alternatively, the first one of the two projections may have a first sloping side surface on a side facing the second one of the two projections and the second one of the two projections may have a second sloping side surface on a side facing the first one of the two projections, the first side surface having a greater size from its top end to its lower end than the second side surface.

**[0029]** For the same purpose, it may moreover or alternatively be provided that the first one of the two projections has a first conical sloping side surface on a side facing the second one of the two projections and the second one of the two projections has a second sloping side surface on a side facing the first one of the two projections, the first side surface having a conical generatrix at a first enclosed angle relative to the cover, the second side surface having a conical generatrix at a second enclosed angle relative to the cover, the first angle being smaller than the second angle.

**[0030]** For achieving such sequential low and high pressure sealings against inner and outer circumferential surface portions of the free end of the enclosing member, it is also advantageous if a first one of the two projections has an extreme top end extending around the capsule axis at a diameter of 31.8 to 32.0 mm and preferably 31.9 mm and the second one of the two projections has an extreme top end extending around the capsule axis at a diameter of 29.7 to 30.0 mm and preferably 29.8 mm. Thus, when used in commercially available coffee making apparatuses such as the Citiz, Lattissima, U, Maestria, Pixie, Inissia and Essenza, an outer edge area of the free end of the enclosing member contacts the outer one of the two projections at a first distance from its extreme top end and an inner edge area of the free end of the enclosing member contacts the inner one of the two projections at a second distance from its extreme top end, the first distance being larger than the second distance, so that the first projection deforms more easily providing the low pressure seal, while the second projection exerts more counter pressure while deforming and provides the high pressure seal. The higher average counter pressure exerted by the second projection is also advantageous for achieving an accommodation to the relatively deep recesses in the inner edge area of the

free end of the enclosing member that is sufficient to achieve a satisfactory high pressure seal.

**[0031]** Preferably, the first one of the two projections is the outer one of the two projections. The capsule is then particularly suitable for use commercially available apparatuses such as the Citiz, Lattissima, U, Maestria, Pixie, Inissia and Essenza in which the free contact end of the annular element is provided with the plurality of radially extending open grooves, the grooves being deeper in the outer surface portion than in the inner surface portion or the grooves are absent in the inner surface portion.

**[0032]** If the plateau is axially spaced from the cover, this area between the first and second projections is displaced axially towards the cover as the enclosing member is closed by means of the closing member of the beverage preparation device. This causes the first projection and the second projection to deform towards the free contact end of the annular element, due to tilting and "rolling off" of the first projection and the second projection, thereby increasing the radial contact pressure exerted against the free contact end of the annular element, which contributes to achieving a satisfactory seal.

**[0033]** In accordance with the invention there is provided in a second aspect a system according to claim 16.

**[0034]** Since the sealing member is integral with the outwardly extending flange and comprises at least one projection of which the top exerts a radial force on the free contact end of the annular element if the capsule is positioned in the enclosing member of the beverage preparation device and the enclosing member is closed by means of a closing member of the beverage preparation device a satisfactory sealing can be obtained. Such a sealing member is relatively easy to manufacture. Furthermore the capsule can provide a satisfactory sealing with the free contact end provided with radially extending open grooves.

**[0035]** The projection or projections may project from at least one base portion of the flange to which base portion the cover is attached. The projection or projections may project axially from the base portion in a direction away from the cover. The projection top may constitute a portion of the projection, for instance a half, a third or a quarter of the projection that is axially most distal from the base portion.

**[0036]** Regarding the preferred embodiments of the system as mentioned in the dependent claims which relate to the same features as the features of the dependent claims of the capsule reference is made to the above.

**[0037]** The invention is particularly suitable in a system according to the invention wherein, in use, the maximum fluid pressure in the enclosing member of the beverage preparation device is in the range of 6-20 bar, preferably between 12 and 18 bar. Even at such high pressures a satisfactory seal between capsule and beverage preparation device can be obtained.

**[0038]** Preferably the system is arranged such that, in use, during brewing, a free end of the

enclosing member of the beverage preparation device exerts a force  $F_2$  on the sealing member of the capsule to provide a fluid sealing contact between the outwardly extending flange of the capsule and the enclosing member of the beverage preparation device, wherein  $F_2$  is in the range of 500-1500 N preferably in the range of 750-1250 N when the fluid pressure  $P_2$  in the enclosing member of the beverage preparation device outside the capsule is in the range of 6-20 bar, preferably between 12 and 18 bar. In particular the system is arranged such that, in use, prior to or at the start of brewing, a free end of the enclosing member of the beverage preparation device exerts a force  $F_1$  on the sealing member of the capsule to provide a fluid sealing contact between the outwardly extending flange of the capsule and the enclosing member of the beverage preparation device, wherein  $F_1$  is in the range of 30-150 N preferably in the range of 40-150 N, more preferably 50-100 N, when the fluid pressure  $P_1$  in the enclosing member of the beverage preparation device outside the capsule is in the range of 0.1 - 4 bar, preferably between 0.1 - 1 bar.

**[0039]** In an embodiment of a system according to the invention wherein the plurality of radially extending open grooves are uniformly spaced relative to each other in tangential direction of the free contact end of the annular element of the beverage preparation device so that it is easier for a user to take out the capsule while a satisfactory seal between capsule and beverage preparation device can still be provided.

**[0040]** In an advantageous embodiment of a system according to the invention the longest tangential width of each groove (top to top, i.e. equal to the groove to groove pitch) is 0.9 - 1.1 mm, preferably 0.95 to 1.05 mm, more preferably 0.98 to 1.02 mm, wherein a maximal height of each groove in an axial direction of the enclosing member of the beverage preparation device is 0.01 - 0.09 mm, preferably 0.03 to 0.07 mm, more preferably 0.045 to 0.055 mm, most preferred 0.05 mm and wherein the number of grooves is 90 to 110, preferably 96. The radial width of the annular end surface at the location of the grooves may for instance be 0.05-0.9 mm, preferably 0.2- 0.7 mm and more preferably 0.3 - 0.55 mm. The invention is in particular suitable when applied to an embodiment of a system according to the invention in which during use when the closing member of the beverage preparation device closes the enclosing member of the beverage preparation device at least the free contact end of the enclosing member of the beverage preparation device can move relative to the closing member of the beverage preparation device under the effect of the pressure of the fluid in the enclosing member of the beverage preparation device towards the closing member of the beverage preparation device for applying the maximum force between the flange of the capsule and the free end of the enclosing member of the beverage preparation device. The enclosing member may comprise a first part and a second part wherein the second part comprises the free contact end of the enclosing member wherein the second part can move relative to the first part between a first and second position. The second part can move from the first position towards the second position in the direction of the closing member under the influence of fluid pressure in the enclosing member. The force  $F_1$  as discussed above may be reached if the second part is in the first position with a fluid pressure  $P_1$ . The force  $F_2$  as discussed above may be reached if the second part is moved towards the second position under the influence of the fluid pressure  $P_2$  in the enclosing member.

**[0041]** In accordance with the invention there is provided in a third aspect a use of a capsule according to claim 21. Regarding the advantage of the inventive use and the preferred embodiments of the use as mentioned in the dependent claims which relate to the same features as the features of the dependent claims of the capsule or the dependent claims of the system reference is made to the above.

**[0042]** The invention will now be further elucidated by means of, nonlimiting, examples referring to the drawing, in which

Fig. 1 shows a schematic representation of an embodiment of a system according to the invention;

Fig. 2 in a perspective view shows an embodiment of a beverage preparation device of a system according to the invention showing the free contact end of the enclosing member of the beverage preparation device with the plurality of radially extending open grooves;

Fig. 3A in cross section shows an embodiment of a capsule according to the invention before use;

Fig. 3B shows an enlarged detail of a the capsule of Fig. 3A showing the outwardly extending flange and the sealing member;

Fig. 3C shows an enlarged detail of the outwardly extending flange of the capsule in Figures 3A and 3B after use;

Fig. 4A shows a first embodiment of a sealing member at the outwardly extending flange of a capsule;

Fig. 4B shows a second embodiment of a sealing member at the outwardly extending flange of a capsule;

Fig. 4C shows a third embodiment of a sealing member at the outwardly extending flange of a capsule;

Fig. 4D shows a fourth embodiment of a sealing member at the outwardly extending flange of a capsule;

Fig. 4E shows a fifth embodiment of a sealing member at the outwardly extending flange of a capsule;

Fig. 4F shows a sixth embodiment of a seal member at the outwardly extending flange of a capsule;

Fig. 4G shows a seventh embodiment of a seal member at the outwardly extending flange of a capsule according to the invention; and

Figs. 5A-5D are schematic representations of successive stages of deformation of the seventh embodiment of a seal member at the outwardly extending flange of a capsule according to the

invention if the capsule is positioned in the enclosing member of the beverage preparation device and as the enclosing member is closed by means of a closing member of the beverage preparation device.

**[0043]** In the Figures and the following description, like reference numerals refer to like features.

**[0044]** Fig. 1 shows a schematic representation, in cross sectional view, of an embodiment of a system 1 for preparing a potable beverage from a capsule using a fluid supplied under pressure into the capsule. The system 1 comprises a capsule 2, and a beverage preparation device 4. The device 4 comprises enclosing member 6 for holding the capsule 2. The device 4 further comprises a closing member, such as an extraction plate, 8 for supporting the capsule 2.

**[0045]** In Fig. 1 a gap is drawn between the capsule 2, the enclosing member 6 and the extraction plate 8 for clarity. It will be appreciated that, in use, the capsule 2 may lie in contact with the enclosing member 6 and the extraction plate member 8. Commonly, the enclosing member 6 has a shape complementary to the shape of the capsule 2. The beverage preparation device 4 further comprises a fluid injection means 10 for supplying an amount of a fluid, such as water, under a pressure in the range of 6-20 bar, preferably between 12 and 18 bar, to the exchangeable capsule 2.

**[0046]** In the example shown in Fig. 1, the exchangeable capsule 2 comprises an aluminum capsule body 12 having a central capsule body axis 12A and an aluminum cover 14. In the present context, the meaning of 'aluminum' is understood to also include aluminum alloy. In this example, the aluminum capsule body 12 comprises a side wall 16, a bottom 18 closing the side wall 16 at a first end, and a outwardly extending flange 20 extending outwardly of the circumferential wall 16 at a second end opposite the bottom 18. The side wall 16, the bottom 18 and the cover 14 enclose an inner space 22 comprising a substance for the preparation of a potable beverage by extracting and/or dissolving the substance. Preferably the substance is an extractable product for the preparation of a potable beverage, the extractable product preferably being 5-20 grams, preferably 5-10 grams, more preferably 5-7 grams of roasted and ground coffee for the preparation of a single beverage. The capsule is initially sealed, i.e. is hermetically closed prior to use.

**[0047]** The system 1 of Fig. 1 comprises bottom piercing means 24 for piercing the bottom 18 of the capsule 2 for creating at least one entrance opening 25 in the bottom 18 for supplying the fluid to the extractable product through the entrance opening 25.

**[0048]** The system 1 of Fig. 1 further comprises cover piercing means 26, here embodied as protrusions of the closing member 8, for piercing the cover 14 of the capsule 2. The cover piercing means 26 may be arranged to tear the cover 14 once a (fluid) pressure inside the

inner space 22 exceeds a threshold pressure and presses the cover 14 against the cover piercing means 26 with sufficient force. The aluminum cover 14 thus is arranged to tear open on the closing member 8 of the beverage preparation device under the influence of fluid pressure in the capsule.

**[0049]** The capsule 2 further comprises a sealing member 28 integral with the outwardly extending flange, in Figures 1, 3A and 3B indicated as a general box but more detailed described with regard to Figure 4, which sealing member 28 is arranged for providing a fluid sealing contact with the enclosing member 6 if the capsule 2 is positioned in the enclosing member 6 and the enclosing member 6 is closed by means of the extraction plate 8, such that the outwardly extending flange 20 of the capsule 2 and at least a portion of the sealing member 28 are sealingly engaged between the enclosing member 6 and the extraction plate 8. This means that a fluid sealing contact between the sealing member and the free contact end is established.

**[0050]** As shown in Figure 2 the enclosing member 6 of the beverage preparation device comprises an annular element 41 having a central annular element axis 41A and a free contact end 30. The free contact end 30 of the annular element 41 is provided with a plurality of radially extending open grooves 40. The plurality of radially extending open grooves 40 are uniformly spaced relative to each other in tangential direction of the free contact end 30 of the annular element 41. The longest tangential width of each groove 40 is 0.9 - 1.1 mm, preferably 0.95 to 1.05 mm, more preferably 0.98 to 1.02 mm, wherein a maximal height of each groove 40 in an axial direction of the enclosing member 6 is 0.01 - 0.09 mm, preferably 0.03 to 0.07 mm, more preferably 0.045 to 0.055 mm, and most preferred 0.05 mm. The number of grooves 40 lies in the range of 90 to 110, preferably 96. Usually, the radial width of the free end at the location of the grooves is 0.05 - 0.9 mm, more specifically 0.2 - 0.7 mm, more specifically 0.3 - 0.55 mm.

**[0051]** An embodiment of a capsule according to the invention is shown more detailed in Figures 3A and 3B. In the shown embodiment the outer diameter ODF of the outwardly extending flange 20 is larger than the diameter DB of the bottom 18 of the capsule 2. In the shown embodiment the outer diameter ODF of the outwardly extending flange 20 is approximately 37.1 mm and the diameter DB of the bottom 18 is about 23.3 mm. The thickness of the aluminum capsule body 12 is such that it is deformed easily if the capsule is positioned in the enclosing member of the beverage preparation device and the enclosing member is closed by means of a closing member of the beverage preparation device, preferably the thickness of the aluminum capsule body is 100 micrometer, but in other embodiments the thickness can be 20 to 200 micrometer.

**[0052]** In the shown embodiment, the wall thickness of the aluminum cover 14 is 39 micrometer. The wall thickness of the aluminum cover 14 is preferably smaller than the thickness of the aluminum capsule body 12.

**[0053]** The side wall 16 of the aluminum capsule body 12 has a free end 42 opposite the

bottom 18. The inner diameter IDF of the free end 42 of the side wall 16 of the aluminum capsule body 12 is about 29.5 mm. The outwardly extending flange 20 extends from that free end 42 in a direction at least substantially transverse to the central capsule body axis 12A. The outwardly extending flange 20 comprises a curled outer edge 43 which is beneficial for obtaining a seal between the capsule and the enclosing member. In the shown embodiment the curled outer edge 43 of the outwardly extending flange 20 has a largest dimension of about 1.2 millimeter. The distance DIF between the free end 42 of the side wall 16 of the aluminum capsule body 12 and an inner edge 43A of the curled outer edge 43 is about 2.7 mm, while the distance DOF between the free end 42 of the side wall 16 of the aluminum capsule body 12 and an outermost edge 43B of the outwardly extending flange 20 is about 3.8 millimeter. The radius about the central capsule body axis of the inner edge 43A of the curled outer edge 43 is preferably at least 32 mm.

**[0054]** As shown in Figures 3A and 3B the sealing member 28 is positioned between the free end of the side wall 16 of the aluminum capsule body 12 and the inner edge 43A of the curled outer edge 42 of the outwardly extending flange. The sealing member 28 is indicated as a general box, but will be described in more detail below. Irrespective of the embodiment of the sealing member 28 the height of the sealing member portion to be contacted first by the free end of the enclosure member when the enclosure member is closed is at least about 0.1 mm, more preferably at least 0.2 mm and most preferably at least 0.8 mm and at most 3 mm, more preferably at most 2 mm and most preferably at most 1.2 mm for providing a correct seal.

**[0055]** As can be seen from Figure 3A the aluminum capsule body 12 is truncated. In the embodiment shown, the side wall 16 of the aluminum capsule body 12 encloses an angle A with a line transverse to the central capsule body axis 12A of about 97.5°. The bottom 18 of the aluminum capsule body 12 has a largest inner diameter DB of about 23.3 mm. The bottom 18 of the aluminum capsule body 12 is also truncated, and in the shown embodiment has a bottom height BH of about 4.0 mm. The bottom 18 further has a generally flat central portion 18A opposite the cover 14, which central portion 18A has a diameter DEE of about 8.3 mm and in which central portion 18A the entrance opening(s) 25 may be made. The entrance openings may also be made in the truncated portion between the central portion 18A and the side wall 16. The total height TH of the aluminum capsule body 12 of the capsule is about 28.4 mm.

**[0056]** The system 1 shown in Fig. 1 is operated as follows for preparing a cup of a potable beverage, in the present example coffee, wherein the substance is roasted and ground coffee.

**[0057]** The capsule 2 is placed in the enclosing member 6. The extraction plate 8 is brought into contact with the capsule 2. The bottom piercing means 24 pierce the bottom 18 of the capsule 2 for creating the entrance openings 25. The fluid, here hot water under pressure, is supplied to the extractable product in the inner space 22 through the entrance openings 25. The water will wet the coffee grounds and extract the desired substances to form the coffee beverage.

**[0058]** During supplying the water under pressure to the inner space 22, the pressure inside

the capsule 2 will rise. The rise in pressure will cause the cover 14 to deform and be pressed against the lid piercing means 26 of the extraction plate. Once the pressure reaches a certain level, the tear strength of the cover 14 will be surpassed and the cover 14 will rupture against the lid piercing means 26, creating exit openings. The prepared coffee will drain from the capsule 2 through the exit openings and outlets 32 (see Fig. 1) of the extraction plate 8, and may be supplied to a container such as a cup (not shown).

**[0059]** The system 1 is arranged such that prior to or at the start of brewing, the free end 30 of the enclosing member 6 exerts a force  $F_1$  on the sealing member 28 of the capsule 2 to provide a fluid sealing contact between the outwardly extending flange 20 of the capsule 2 and the enclosing member 6 of the beverage preparation device, wherein  $F_1$  is in the range of 30-150 N preferably 40-150 N, more preferably 50-100 N, when the fluid pressure  $P_1$  in the enclosing member of the beverage preparation device outside the capsule is in the range of 0.1-4 bar, preferably 0.1-1 bar. During brewing, the free end 30 of the enclosing member 6 exerts a force  $F_2$  on the sealing member 28 of the capsule 2 to provide a fluid sealing contact between the outwardly extending flange 20 of the capsule 2 and the enclosing member 6, wherein the force  $F_2$  is in the range of 500 -1500 N, preferably in the range of 750-1250 N, when the fluid pressure  $P_2$  in the enclosing member 6 of the beverage preparation device outside the capsule 2 is in the range of 6-20 bar, preferably between 12 and 18 bar. In the shown embodiment the free contact end of enclosing member 6 can move relative to the extracting plate 8 under the effect of the pressure of the fluid in the enclosing member 6 device towards the extraction plate 8 for applying the maximum force  $F_2$  between the outwardly extending flange 20 and the free end 30 of the enclosing member 6. This movement can take place during use, i.e. in particular at the start of brewing and during brewing. The enclosing member 6 has a first part 6A and a second part 6B wherein the second part comprises the free contact end 30. The second part 6B can move relative to the first part 6A between a first and second position. The second part 6B can move from the first position towards the second position in the direction of the closing member 8 under the influence of fluid pressure in the enclosing member 6. The force  $F_1$  as discussed above may be reached if the second part 6B is in the first position with a fluid pressure  $P_1$ . The force  $F_2$  as discussed above may be reached if the second part 6B is moved towards the second position under the influence of the fluid pressure  $P_2$  in the enclosing member 6.

**[0060]** As a result of the force applied the sealing member 28 of the capsule according to the invention undergoes a plastic deformation and closely conforms to the grooves 40 of the free contact end 30 and thus provides a fluid sealing contact between the enclosing member 6 and the capsule 3 at a relatively low fluid pressure during start up of brewing but also provides a fluid sealing contact at the much higher fluid pressure in the enclosing member outside the capsule during brewing. This close conformation to the grooves 40 of the enclosing member is indicated in Figure 3C which shows the capsule 2 of the invention after use, and which clearly indicates that the outwardly extending flange 20 comprises deformations 40' which conform to the grooves 40 of the enclosing member.

**[0061]** Now exemplary embodiments of a sealing member 28 at the outwardly extending

flange 20 of the capsule 2 according to the invention will be described in more detail with regard to Fig. 4.

**[0062]** Fig. 4A shows a first embodiment of a sealing member 28 forming an additional bearing at the outwardly extending flange 20 of a capsule 2. The sealing member and the remainder of the capsule body are made of the same plate material. The sealing member 28 comprises two spaced projections 50 and 51, each projecting axially from a base portion of the outwardly extending flange 20, to which base portion the cover 14 is attached, in a direction away from the cover 14. A plateau 52 is present between the two projections 50 and 51. The distance between the two projections 50 and 51 is such that the free contact end of the annular element 6 is squeezed between converging surfaces of the two projections 50 and 51 if the capsule is positioned in the enclosing member of the beverage preparation device and the enclosing member is closed by means of a closing member of the beverage preparation device. In the embodiment shown in Figure 4A the plateau is positioned at a distance above the portion of the outwardly extending flange 20 between the sealing member 28 and the curled edge 43 and is substantially flat. The distance between the two projections 50 and 51 is further such that the free contact end of the annular element is contacted by the two projections 50 and 52 if the capsule is positioned in the enclosing member of the beverage preparation device and the enclosing member is closed by means of a closing member of the beverage preparation device. Further, the two spaced projections 50, 51 and the plateau 52 are arranged such that the free contact end of the annular element is contacted by the plateau if the capsule is positioned in the enclosing member of the beverage preparation device and the enclosing member is closed by means of a closing member of the beverage preparation device. As can be seen in Figure 4A each projection 50, 51 comprises a projection side wall which is inclined with regard to the outwardly extending flange 20 of the aluminum capsule body. The projection side wall is configured such that it is deformed easily if the capsule is positioned in the enclosing member of the beverage preparation device and the enclosing member is closed by means of a closing member of the beverage preparation device.

**[0063]** Fig. 4B shows a second embodiment of a sealing member 28 at the outwardly extending flange 20 of a capsule. When compared with Figure 4A the following differences are noted. Each projection 50, 51 now comprises a projection side wall which is transverse with regard to the outwardly extending flange 20 of the aluminum capsule body. Further, in this second embodiment the plateau 52 is curved, preferably conforming to the shape of the free contact end of the annular element 6.

**[0064]** Fig. 4C shows a third embodiment of a sealing member 28 at the outwardly extending flange 20 of a capsule, which together with the side wall 16 of the aluminum capsule body forms an additional bearing for the enclosing member. The shown sealing member 28 comprises a projection 53 projecting from the outwardly extending flange 20 and an inclined, substantially flat plateau 52 between a rounded topmost end portion of the projection 53 and the side wall 16 of the aluminum capsule body. In this embodiment the bearing is formed by the projection 53, the plateau 52 and the side wall 16 of the aluminum capsule body. The distance between the top of the projection 53 and the side wall 16 is such that the free contact

end of the annular element 6 is enclosed by the projection 53 and the side wall 16 of the aluminum capsule body if the capsule is positioned in the enclosing member of the beverage preparation device and the enclosing member is closed by means of a closing member of the beverage preparation device. In particular the distance between the projection 53 and the side wall 16 of the aluminum capsule body is such that the free contact end of the annular element 6 is contacted by the projection 53 and the side wall 16 and in the shown embodiment also the plateau 52 of the aluminum capsule body if the capsule is positioned in the enclosing member of the beverage preparation device and the enclosing member is closed by means of a closing member of the beverage preparation device.

**[0065]** Fig. 4D shows a fourth embodiment of a sealing member 28 at the outwardly extending flange 20 of a capsule, which together with the side wall 16 of the aluminum capsule body forms an additional bearing for the enclosing member. When compared with Figure 4C the following differences are noted. In this fourth embodiment the plateau 52 is curved, and comprises a curved portion and also a flat portion which is situated at the same level as the portion of the outwardly extending flange 20 between the projection 53 and the curved edge 43. The curved portion preferably conforms to the shape of the free contact end of the annular element 6. Fig. 4E shows a fifth embodiment of a sealing member 28 at the outwardly extending flange 20 of a capsule, which together with the side wall 16 of the aluminum capsule body forms a bearing for the enclosing member. When compared with Figure 4D the following difference is noted. In this fifth embodiment the flat portion of the plateau 52 is situated at a distance above the portion of the outwardly extending flange 20 between the projection 53 and the curved edge 43. The distance between the projection 53 is preferably 0.9-1.25 mm, which allows the free end of the closing member of widely used and commercially available beverage preparation devices (such as the Citiz, Lattissima, U, Maestria, Pixie, Inissia and Essenza) to be reliably squeezed against the projections 53 with the side wall 16 in close proximity thereto..

**[0066]** In the embodiments shown in Figures 4C to 4E the projection 53 comprises an outer projection side wall 54 which is transverse to the portion of the outwardly extending flange between the projection 53 and the curled edge 43, but in other embodiments this outer projection side wall 54 can be inclined with regard to the portion of the outwardly extending flange 20.

**[0067]** In all the embodiments shown in Figures 4A to 4E each of the projections comprises a projection top constituting a portion of the projection, for instance a half, a third or a quarter of the projection, that is axially most distal from the base portion of the flange 28 to which the cover 14 is attached. At least one projection but preferably all projections forming the additional bearing is/are configured such that its projection top exerts a radial force on the free contact end of the annular element 6 if the capsule is positioned in the enclosing member of the beverage preparation device and the enclosing member is closed by means of a closing member of the beverage preparation device.

**[0068]** Fig. 4F shows a sixth embodiment of a seal member 28 at the outwardly extending

flange 20 of a capsule. When compared with e.g. Figure 4B the following differences are noted. In this sixth embodiment the plateau 52 is V-shaped, with the bottom of the V-shaped being at the same level as the base portion of the outwardly extending flange 20 between the outer projection 51 and the curled edge 43. In this manner no bearing for the free contact end of the annular member 6 is formed, but the projection top of the inner projection 50 exerts a radial force direct outwardly on the free contact end of the annular element 6 and the projection top of the outer projection 51 exerts a radial force direct inwardly on the free contact end of the annular element 6 if the capsule is positioned in the enclosing member of the beverage preparation device and the enclosing member is closed by means of a closing member of the beverage preparation device. In this manner the free contact end is squeezed by the sealing member 28 thereby providing a satisfactory seal.

**[0069]** In capsules in which the sealing structure 28 has projections 50, 51 and a plateau or through 52 in between, as by way of example shown in Figs. 4A, 4B, and 4F, the center of the plateau or through 52, which extends circumferentially around the center axis of the capsule, preferably has a diameter of 29-33 mm, more preferably 30.0-31.4 mm and most preferably 30.3-31.0 mm, so that (seen in radial cross-section) the free end of the closing member of widely used and commercially available beverage preparation devices (such as the Citiz, Lattissima, U, Maestria, Pixie, Inissia and Essenza) lands accurately centered between the projections 50, 51 and the squeezing effect is evenly distributed over the inner and outer projections 50, 51. For effective squeezing in such apparatuses, the distance between projections 50, 51 is preferably 0.9-1.25 mm.

**[0070]** Fig. 4G shows a seventh embodiment of a seal member 28 at the outwardly extending flange 20 of a capsule according to the invention. As also shown in Fig. 2, the enclosing member 6 of the beverage preparation device has an annular element 41 having a free contact end 30 with a plurality of radially extending open grooves 40 of which some are shown in Fig. 4G.

**[0071]** As in the examples shown in Figs. 4A, 4B and 4F, the sealing member 28 has two spaced projections 50 and 51, each projecting axially from a base portion 21, 23 of the outwardly extending flange 20, to which base portions 21, 23 the cover 14 is attached, in a direction away from the cover 14. As in the example shown in Fig. 4F, a generally V-shaped plateau 52 having a rounded bottom is located between the two projections 50 and 51.

**[0072]** A difference compared with the examples shown in Figs. 4A, 4B and 4F is that, in the example shown in Fig. 4G, a first one of the two projections 51 projects further from the base portions 21, 23 of the outwardly extending flange 20 than a second one of the two projections 50.

**[0073]** As shown in the more schematical Figs. 5A-5D, the free contact end 30 of the annular element 41 first contacts the first one of the two projections 51 (Fig. 5A) and subsequently contacts the second one of the two projections (Fig. 5B) if the capsule is positioned in the enclosing member 6 of the beverage preparation device and as the enclosing member 6 is

closed by means of the closing member of the beverage preparation device.

**[0074]** As can also be seen from Figs. 5A-5D, if the enclosing member is closed by means of the closing member, the free contact end 30 of the annular element 41 has a first circumferential surface portion 71 contacting the first projection 51 and a second circumferential surface portion 70 contacting the second projection 50. The radially extending open grooves 40 are deeper in the second surface portion 70 than in the first surface portion 71 or the grooves may be absent in the first surface portion 71.

**[0075]** When the free contact end 30 of the annular element 41 contacts the first one of the two projections 51, the capsule is centered relative to the enclosing member 6 and an initial seal is achieved which provides satisfactory sealing against a low pressure drop at a relatively low pressing force (Figs, 5B and 5C). When the free contact end 30 of the annular element 41 contacts the second one of the two projections 50, more contact force is exerted and the second projection exerts a relatively high counter force as it is deformed (Figs. 5C and 5D), the relatively high counter pressure causes material of the second projection to be reliably deformed locally so that it is pressed into the relatively deep areas of the recesses 40.

**[0076]** The distance between the two projections 50 and 51 is such that ultimately (Fig. 5D) the free contact end 30 of the annular element 41 is squeezed between converging surfaces of the two projections 50 and 51 when the enclosing member is fully closed by means of the closing member. As can be seen in Figure 4A each projection 50, 51 comprises a projection side wall which is inclined with regard to the outwardly extending flange 20 of the aluminum capsule body.

**[0077]** The plateau 52 has a bottom end which is radially closer to the projection top of the second one of the projections 50 than to the projection top of the first one of the projections 51. This allows the higher first projection 51 to have a relatively long and (in top view) wide side on its side facing the second projection 52. This allows centering of the capsule from a wide range of initial positions.

**[0078]** The sloping side surface 61 on a side of the first projection 51 facing the second one of the two projections 50 has a greater size from its top end to its lower end than the opposite second side surface of the second projection 52. Also this feature contributes to the free contact end 30 of the annular element 41 first contacting the first one of the two projections 51 and subsequently contacting the second one of the two projections 50 as the enclosing member 6 is closed by means of the closing member. Moreover, the relatively large width of the first side surface causes the surface to be deformable relatively easily when contact by an edge area of the free end 30 of the annular element 41, which is advantageous for providing a satisfactory seal already at a relatively low contact pressure. The difference in size from the top to the end is preferably at least 10% and more preferably at least 20%.

**[0079]** For the same purposes, it is also advantageous that the first sloping side surface 61 has a conical generatrix at an enclosed angle relative to the cover 14 that is smaller than the

enclosed angle between a second conical generatrix between the second side surface 60 and the cover 14. The difference between the angles is preferably at least 10° and more preferably at least 20°. The first angle is preferably between 40° and 60° and more preferably larger than 45° and/or smaller than 55°. The second angle is preferably between 60° and 85° and more preferably larger than 70° and/or smaller than 80°.

**[0080]** For achieving sequential low and high pressure sealings against inner and outer circumferential surface portions of the free end 30 of the annular element 41, it is also advantageous if the free contact end 30 of the annular element 41 contacts the first projection 61 at a first radial distance from an extreme top end of the first projection and contacts the second projection at a second radial distance from an extreme top end from the second projection which is smaller than this first distance. This causes or contributes to the first projection 51 deforming more easily providing the low pressure seal, while the second projection 50 exerts more counter pressure while deforming and provides the high pressure seal. The higher average counter pressure exerted by the second projection 50 is also advantageous for achieving an accommodation to the relatively deep recesses 40 in the inner edge area of the free end 30 of the annular element 41 that is sufficient to achieve a satisfactory high pressure seal.

**[0081]** The plateau 52 is axially spaced from the cover 14. As illustrated by Figs 5A-5D, this allows the plateau 52 between the projections 50, 51 to be displaced in the direction of movement of the free end 30 of the annular element 41 as the enclosing member 6 is closed, urging the projections 50, 51 to be tilted and roll off inwardly against the free end 30 of the annular element 41 as the enclosing member 6 is closed. This increases the radial sealing pressure that is exerted (in addition to the axial closing pressure), so that an increased sealing pressure is available for providing a satisfactory seal.

**[0082]** In the foregoing specification, the invention has been described with reference to specific examples of embodiments of the invention.

## **REFERENCES CITED IN THE DESCRIPTION**

This list of references cited by the applicant is for the reader's convenience only. It does not form part of the European patent document. Even though great care has been taken in compiling the references, errors or omissions cannot be excluded and the EPO disclaims all liability in this regard.

### **Patent documents cited in the description**

- [EP1700548B](#) [0004]

- WO2014184653A1 [0004]

## PATENTKRAV

1. Kapsel, der indeholder en substans til tilberedning af en drikkelig drikkevare ved ekstraktion og/eller opløsning af substansen ved hjælp af tilførsel ind i kapslen af en væske under tryk, hvor kapslen omfatter en aluminiumkapselkrop med en central kapselkropakse, hvor

5 aluminiumkapselkroppen er forsynet med en bund, en sidevæg og en flange, der strækker sig udad, hvilken kapsel endvidere omfatter et aluminiumdæksel, der er fastgjort til flangen, der strækker sig udad, idet dækslet lukker kapslen hermetisk, hvor kapslen endvidere omfatter et forseglingselement ved flangen, der strækker sig udad, til tilvejebringelse af en

10 væskeforseglingkontakt med et indkapslingselement i en drikkevaretilberedningsindretning, hvis kapslen anbringes i indkapslingselementet i drikkevaretilberedningsindretningen, og indkapslingselementet lukkes ved hjælp af et tillukningselement i drikkevaretilberedningsindretningen, såsom en ekstraktionsplade i drikkevaretilberedningsindretningen, således at kapslens flange, der strækker sig udad, og mindst

15 en del af kapslens forseglingselement er i forseglende indgreb mellem indkapslingselementet og tillukningselementet i drikkevaretilberedningsindretningen, hvor indkapslingselementet i drikkevaretilberedningsindretningen omfatter et ringformet element med en central ringformet element-akse og en fri kontaktende, hvilken frie kontaktende i det ringformede element valgfrit er forsynet med en flerhed af åbne riller, der strækker radialt udad, **kendetegnet ved, at**, forseglingselementet er integralt med flangen, der strækker sig udad, og omfatter mindst et

20 fremspring, der rager ud fra flangen, som strækker sig udad, hvor det mindst ene fremspring omfatter en fremspringstop, og hvor det mindst ene fremspring er konfigureret således, at fremspringstoppen udøver en radial kraft på den frie kontaktende i det ringformede element, hvis kapslen anbringes i indkapslingselementet i drikkevaretilberedningsindretningen, og indkapslingselementet lukkes ved hjælp af tillukningselementet i

25 drikkevaretilberedningsindretningen, hvor forseglingselementet omfatter et yderligere fremspring, der rager ud fra flangen, som strækker sig udad, og et plateau mellem de to fremspring, hvor afstanden mellem de to fremspring er således, at den frie kontaktende i det ringformede element er indesluttet mellem de to fremspring, hvis kapslen anbringes i indkapslingselementet, og indkapslingselementet lukkes ved hjælp af tillukningselementet, og

30 hvor et første af de to fremspring rager længere ud fra en basisdel af flangen, der strækker sig udad, til hvilken basisdel dækslet er fastgjort, end et andet af de to fremspring.

2. Kapsel ifølge krav 1, hvor plateauet har en nedre ende, der er radialt tættere på fremspringstoppen af det andet af fremspringene, end på fremspringstoppen af det første af fremspringene.
- 5 3. Kapsel ifølge krav 1 eller 2, hvor et første af de to fremspring har en første konisk skrånende sideflade på en side, der vender mod et andet af de to fremspring, og det andet af de to fremspring har en anden konisk skrånende sideflade på en side, der vender mod det første af de to fremspring, hvilken første sideflade er større fra den øverste ende til den nederste ende end den anden sideflade.
- 10 4. Kapsel ifølge et hvilket som helst af kravene 1-3, hvor et første af de to fremspring har en første konisk skrånende sideflade på en side, der vender mod et andet af de to fremspring, og det andet af de to fremspring har en anden skrånende sideflade på en side, der vender mod det første af de to fremspring, hvilken første sideflade har en konisk frembringer i en første indesluttet vinkel i  
15 forhold til dækslet, hvor den anden sideflade har en konisk frembringer i en anden indesluttet vinkel i forhold til dækslet, hvilken første vinkel er mindre end den anden vinkel.
5. Kapsel ifølge krav 4, hvor den første vinkel er mellem  $40^\circ$  og  $60^\circ$ , fortrinsvis mere end  $45^\circ$  og fortrinsvis mindre end  $55^\circ$ .
- 20 6. Kapsel ifølge krav 4 eller 5, hvor den anden vinkel er mellem  $60^\circ$  og  $85^\circ$ , fortrinsvis mere end  $70^\circ$  og fortrinsvis mindre end  $80^\circ$ .
7. Kapsel ifølge et hvilket som helst af kravene 1-6, hvor et første af de to fremspring  
25 har en ekstrem øverste ende, der strækker sig omkring kapslens akse i en diameter på 31,8 til 32,0 mm og fortrinsvis 31,9 mm, og hvor et andet af de to fremspring har en ekstrem øverste ende, der strækker sig omkring kapslens akse i en diameter på 29,7 til 30,0 mm og fortrinsvis 29,8 mm.
- 30 8. Kapsel ifølge et hvilket som helst af kravene 1-7, hvor det første af de to fremspring er et ydre fremspring af de to fremspring.
9. Kapsel ifølge et hvilket som helst af kravene 1-8, hvor plateauet er anbragt med mellemrum aksialt fra dækslet.

10. Kapsel ifølge et hvilket som helst af kravene 1-9, hvor afstanden mellem de to fremspring er således, at den frie kontaktende i det ringformede element kommer i kontakt med de to fremspring, hvis kapslen anbringes i indkapslingselementet, og indkapslingselementet lukkes ved hjælp af tillukningselementet.
11. Kapsel ifølge et hvilket som helst af kravene 1-10, hvor de to med mellemrum anbragte fremspring og plateauet anbringes således, at den frie kontaktende i det ringformede element kommer i kontakt med plateauet, hvis kapslen anbringes i indkapslingselementet, og indkapslingselementet lukkes ved hjælp af tillukningselementet.
12. Kapsel ifølge et hvilket som helst af kravene 1-11, hvor kapslen omfatter et leje til indkapslingselementet, hvis kapslen anbringes i indkapslingselementet, og indkapslingselementet lukkes ved hjælp af tillukningselementet, hvilket leje indkapsler mindst en del af den frie kontaktende i det ringformede element, og lejet dannes af de to fremspring og plateauet derimellem.
13. Kapsel ifølge et hvilket som helst af kravene 1-12, hvor plateauet i det væsentlige er fladt.
14. Kapsel ifølge et hvilket som helst af kravene 1-12, hvor plateauet omfatter en kurvet del, og plateauet fortrinsvis er V-formet.
15. Kapsel ifølge et hvilket som helst af de foregående krav, hvor forseglingsstrukturen og resten af kapselkroppen er fremstillet af det samme plademateriale.
16. System til tilberedning af en drikkelig drikkevare ud fra en kapsel under anvendelse af en væske, der under tryk tilføres kapslen, hvilket system omfatter:  
en drikkevaretilberedningsindretning, der omfatter et indkapslingselement til modtagelse af kapslen, hvor indkapslingselementet omfatter væskeinjektionsmidler til tilførsel ind i kapslen af væske under tryk, hvor drikkevaretilberedningsindretningen endvidere omfatter et tillukningselement, såsom en ekstraktionsplade, til tillukning af indkapslingselementet i drikkevaretilberedningsindretningen, hvor indkapslingselementet i drikkevaretilberedningsindretningen endvidere omfatter et ringformet element med en central

ringformet element-akse og en fri kontaktende, hvilken frie kontaktende i det ringformede element valgfrit er forsynet med en flerhed af åbne riller, der strækker radially udad;

en kapsel, der indeholder en substans til tilberedning af en drikkelig drikkevare ved ekstraktion og/eller opløsning af substansen ved hjælp af væsken, der under tryk tilføres

5 kapslen med væskeinjektionsmidlerne i drikkevaretilberedningsindretningen, hvor kapslen omfatter en aluminiumkapselkrop med en central kapselkropakse, hvor aluminiumkapselkroppen er forsynet med en bund, en sidevæg og en flange, der strækker sig udad, hvilken kapsel endvidere omfatter et aluminiumdæksel, der er fastgjort til flangen, der strækker sig udad, idet dækslet lukker kapslen hermetisk, hvor kapslen endvidere omfatter et

10 forseglingselement ved flangen, der strækker sig udad, til tilvejebringelse af en væskeforseglingkontakt med indkapslingselementet i drikkevaretilberedningsindretningen, hvis kapslen anbringes i indkapslingselementet i drikkevaretilberedningsindretningen, og indkapslingselementet lukkes ved hjælp af tillukningselementet i drikkevaretilberedningsindretningen, således at kapslens flange, der strækker sig udad, og

15 mindst en del af kapslens forseglingselement er i forseglende indgreb mellem indkapslingselementet og tillukningselementet i drikkevaretilberedningsindretningen, **kendetegnet ved, at** forseglingselementet er integralt med flangen, der strækker sig udad, og omfatter mindst et fremspring, der rager ud fra flangen, som strækker sig udad, hvor det mindst ene fremspring omfatter en fremspringstop, og hvor det mindst ene fremspring er konfigureret

20 således, at fremspringstoppen udøver en radial kraft på den frie kontaktende i det ringformede element, hvis kapslen anbringes i indkapslingselementet i drikkevaretilberedningsindretningen, og indkapslingselementet lukkes ved hjælp af tillukningselementet i drikkevaretilberedningsindretningen, hvor forseglingselementet omfatter et yderligere fremspring, der rager ud fra flangen, som strækker sig udad, og et plateau mellem de to

25 fremspring, hvor afstanden mellem de to fremspring er således, at den frie kontaktende i det ringformede element er indeklemt mellem konvergerende flader på de to fremspring, hvis kapslen anbringes i indkapslingselementet i drikkevaretilberedningsindretningen, og indkapslingselementet lukkes ved hjælp af tillukningselementet i drikkevaretilberedningsindretningen, og hvor et første af de to fremspring rager længere ud fra

30 en basisdel af flangen, der strækker sig udad, til hvilken basisdel dækslet er fastgjort, end et andet af de to fremspring, således at den frie kontaktende i det ringformede element først kommer i kontakt med det første af de to fremspring og efterfølgende kommer i kontakt med det andet af de to fremspring, hvis kapslen anbringes i indkapslingselementet, og idet indkapslingselementet lukkes ved hjælp af tillukningselementet.

17. System ifølge krav 16, hvor et første af de to fremspring har en første skrånende sideflade på en side, der vender mod et andet af de to fremspring, og det andet af de to fremspring har en anden skrånende sideflade på en side, der vender mod det første af de to fremspring, hvilken første sideflade er større fra den øverste ende til den nederste ende end den anden sideflade, således at den frie kontaktende i det ringformede element først kommer i kontakt med det første af de to fremspring og efterfølgende kommer i kontakt med det andet af de to fremspring, hvis kapslen anbringes i indkapslingselementet, og idet indkapslingselementet lukkes ved hjælp af tillukningselementet.

10

18. System ifølge et hvilket som helst af kravene 16-17, hvor et første af de to fremspring har en første konisk skrånende sideflade på en side, der vender mod et andet af de to fremspring, og det andet af de to fremspring har en anden skrånende sideflade på en side, der vender mod det første af de to fremspring, hvilken første sideflade har en konisk frembringer i en første indesluttet vinkel i forhold til dækslet, hvor den anden sideflade har en konisk frembringer i en anden indesluttet vinkel i forhold til dækslet, hvilken første vinkel er mindre end den anden vinkel, således at den frie kontaktende i det ringformede element først kommer i kontakt med det første af de to fremspring og efterfølgende kommer i kontakt med det andet af de to fremspring, hvis kapslen anbringes i indkapslingselementet, og idet indkapslingselementet lukkes ved hjælp af tillukningselementet.

20

19. System ifølge et hvilket som helst af kravene 16-18, hvor den frie kontaktende i det ringformede element kommer i kontakt med et første af de to fremspring i en første radial afstand fra en ekstrem øverste ende af fremspringet og kommer i kontakt med et andet af de to fremspring i en anden radial afstand fra en ekstrem øverste ende fra det andet fremspring, hvis kapslen anbringes i indkapslingselementet, og idet indkapslingselementet lukkes ved hjælp af tillukningselementet, hvor et første af de to fremspring har en ekstrem øverste ende, der strækker sig omkring systemets akse i en første diameter, og hvor det andet af de to fremspring har en ekstrem øverste ende, der strækker sig omkring systemets akse i en anden diameter, som er forskellig fra den første diameter, således at den første radiale afstand er større end den anden radiale afstand.

30

20. System ifølge et hvilket som helst af kravene 16-19, hvor den frie kontaktende i det ringformede element har en første periferifladedel, der kommer i kontakt med det første fremspring, hvis kapslen anbringes i indkapslingselementet, og idet indkapslingselementet

lukkes ved hjælp af tillukningsselementet, og en anden periferifladedel, der kommer i kontakt med det andet fremspring, hvis kapslen anbringes i indkapslingsselementet, og idet indkapslingsselementet lukkes ved hjælp af tillukningsselementet, hvor den frie kontaktende i det ringformede element er forsynet med flerheden af åbne riller, der strækker radialt udad, hvilke riller er dybere i den anden flade del end i den første flade del, eller rillerne er fraværende i den første flade del.

21.       Anvendelse af en kapsel ifølge et hvilket som helst af kravene 1 til 15 i en drikkevaretilberedningsindretning, der omfatter et indkapslingsselement til modtagelse af kapslen, hvor indkapslingsselementet omfatter væskeinjektionsmidler til tilførsel ind i kapslen af væske under tryk, hvor drikkevaretilberedningsindretningen endvidere omfatter et tillukningsselement, såsom en ekstraktionsplade, til tillukning af indkapslingsselementet i drikkevaretilberedningsindretningen, hvor indkapslingsselementet i drikkevaretilberedningsindretningen endvidere omfatter et ringformet element med en central ringformet element-akse og en fri kontaktende, hvilken frie kontaktende i det ringformede element valgfrit er forsynet med en flerhed af radiale riller; hvor kapslen indeholder en substans til tilberedning af en drikkelig drikkevare ved ekstraktion og/eller opløsning af substansen ved hjælp af væsken, der under tryk tilføres kapslen med væskeinjektionsmidler i drikkevaretilberedningsindretningen, hvor kapslen omfatter en aluminiumkapselkrop med en central kapselkropakse, hvilken aluminiumkapselkrop er forsynet med en bund, en sidevæg og en flange, der strækker sig udad, idet kapslen endvidere omfatter et aluminiumdæksel, der er fastgjort til flangen, som strækker sig udad, idet dækslet lukker kapslen hermetisk, hvor kapslen endvidere omfatter et forseglingsselement integralt med flangen, der strækker sig udad, til tilvejebringelse af en væskeforseglingkontakt med indkapslingsselementet i drikkevaretilberedningsindretningen, hvis kapslen anbringes i indkapslingsselementet i drikkevaretilberedningsindretningen, og indkapslingsselementet lukkes ved hjælp af tillukningsselementet,

således at den flange, der strækker sig udad af kapslen, og mindst en del af kapslens forseglingsselementet er i forseglende indgreb mellem indkapslingsselementet og tillukningsselementet i drikkevaretilberedningsindretningen.

DRAWINGS

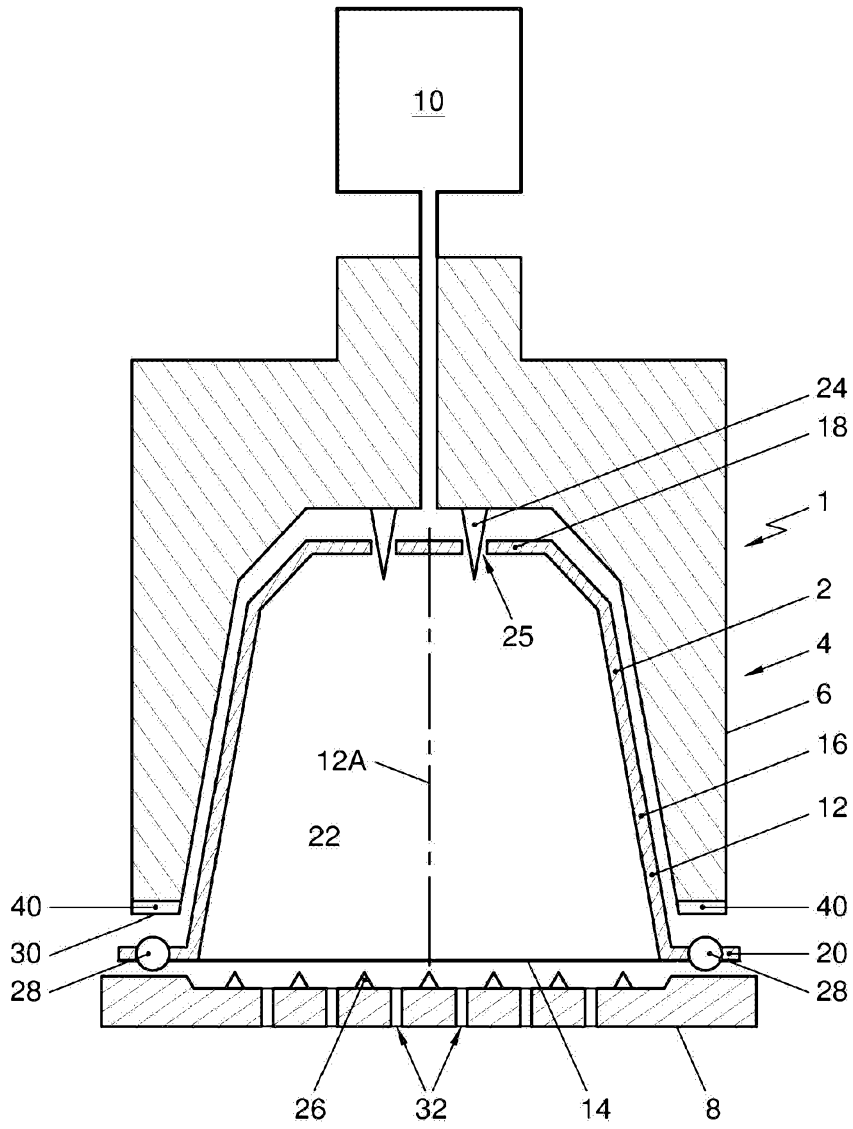

Fig. 1

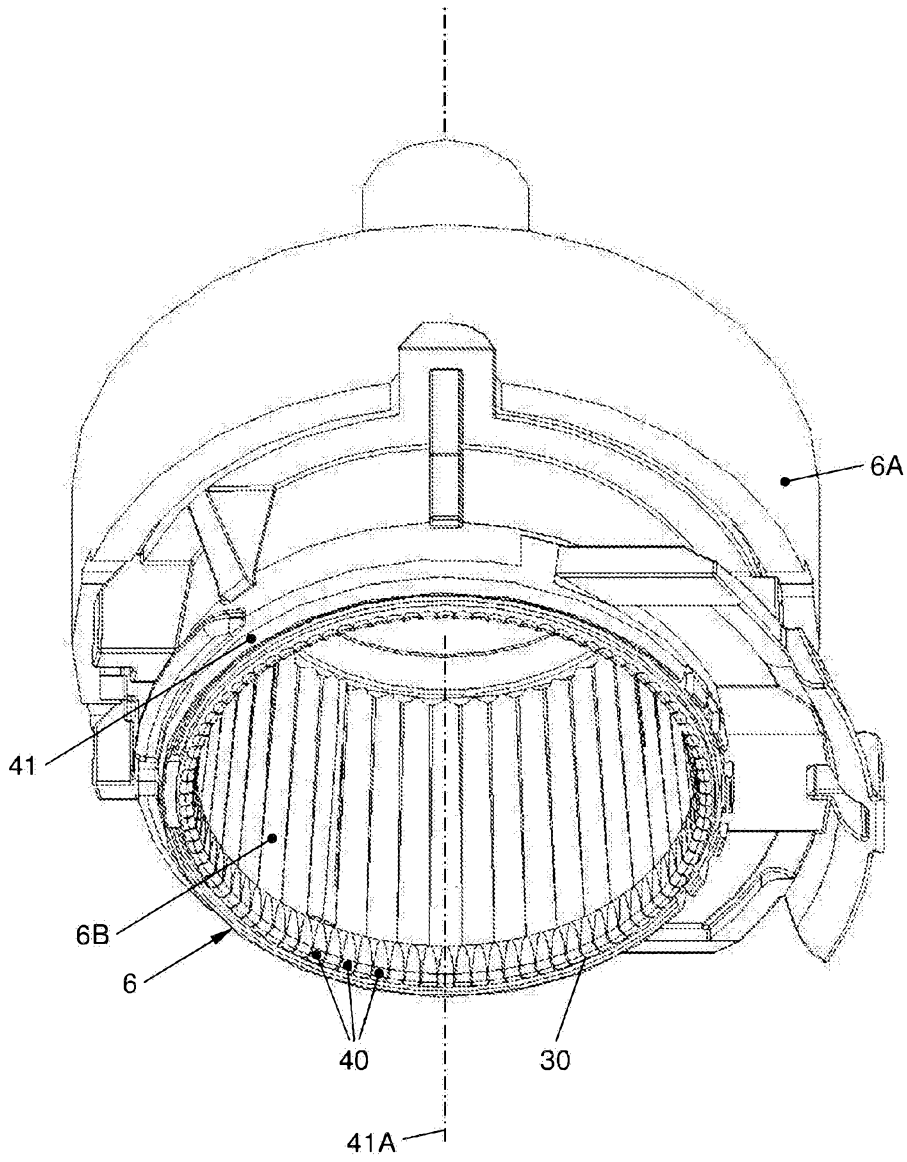

Fig. 2

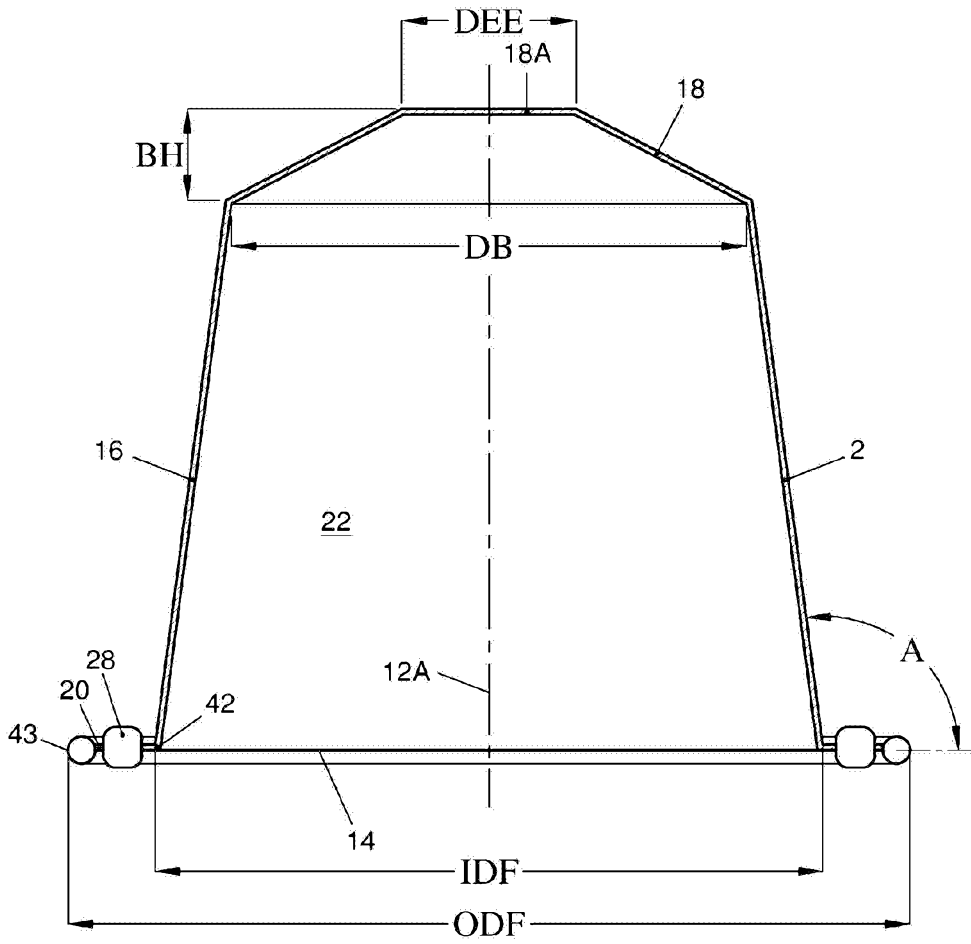

Fig. 3A

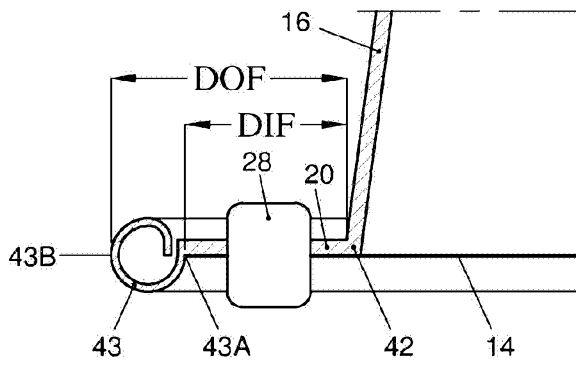

Fig. 3B

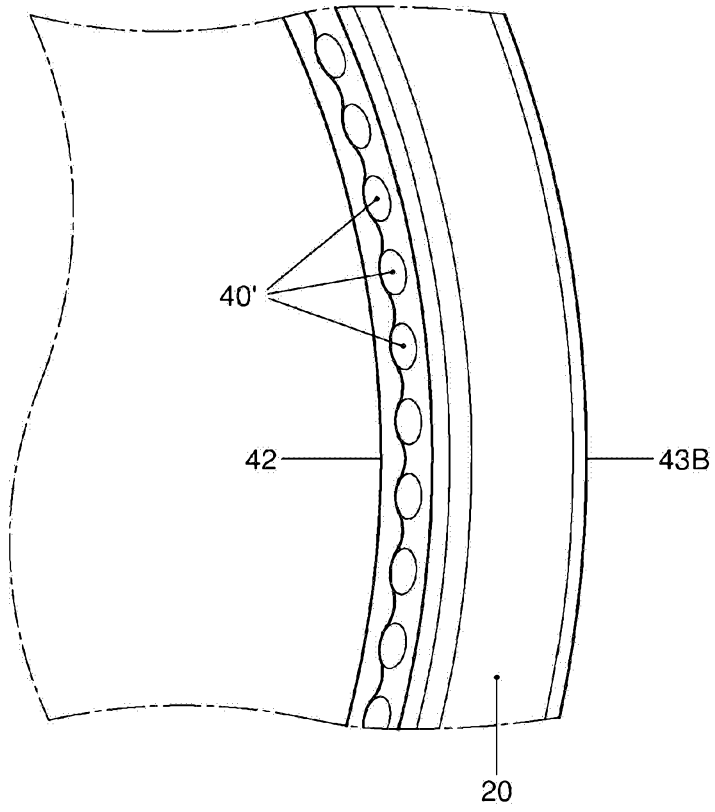

Fig. 3C

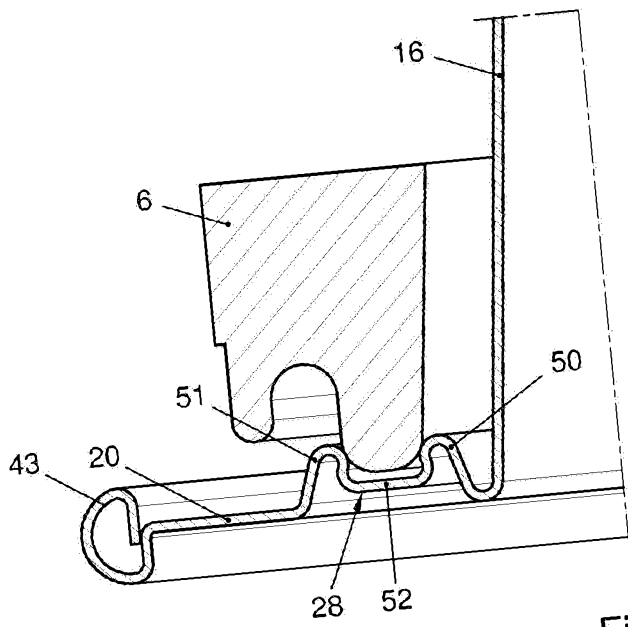

Fig. 4A

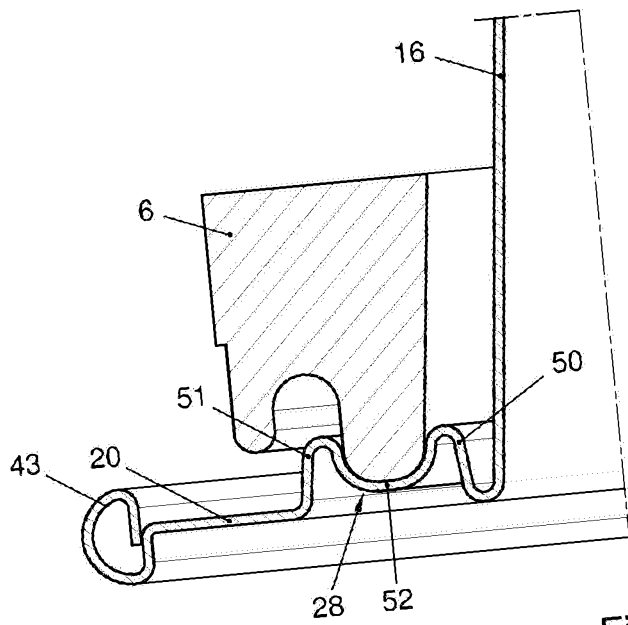

Fig. 4B

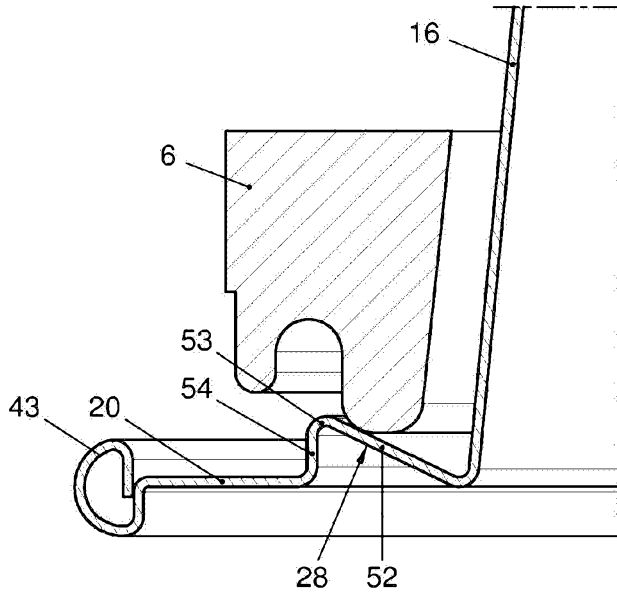

Fig. 4C

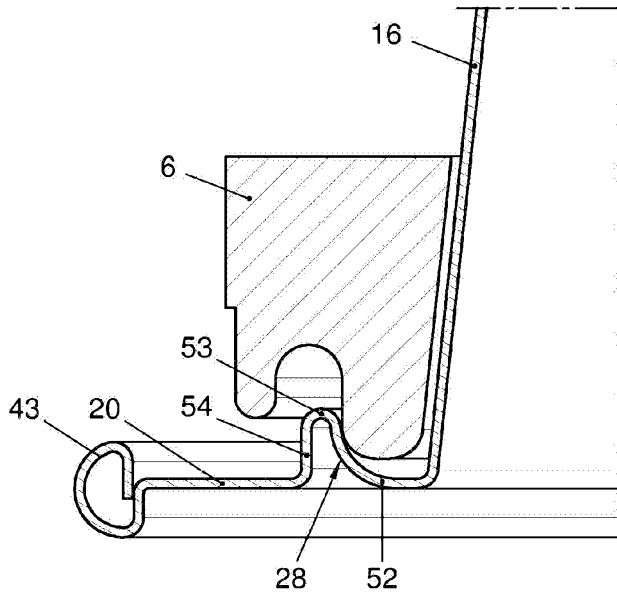

Fig. 4D

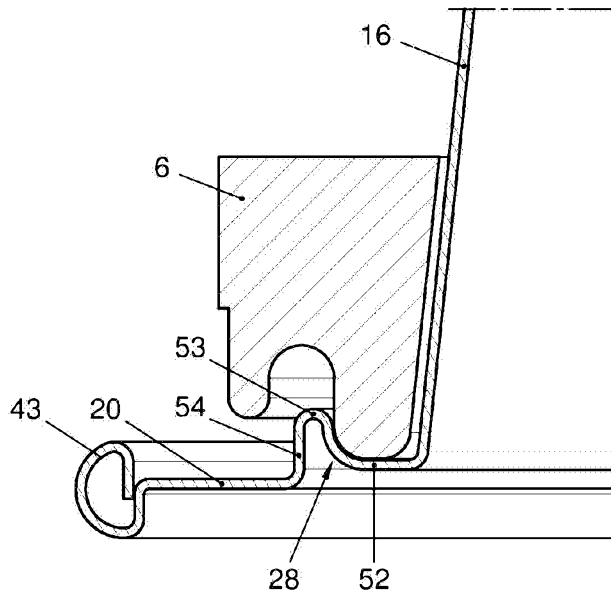

Fig. 4E

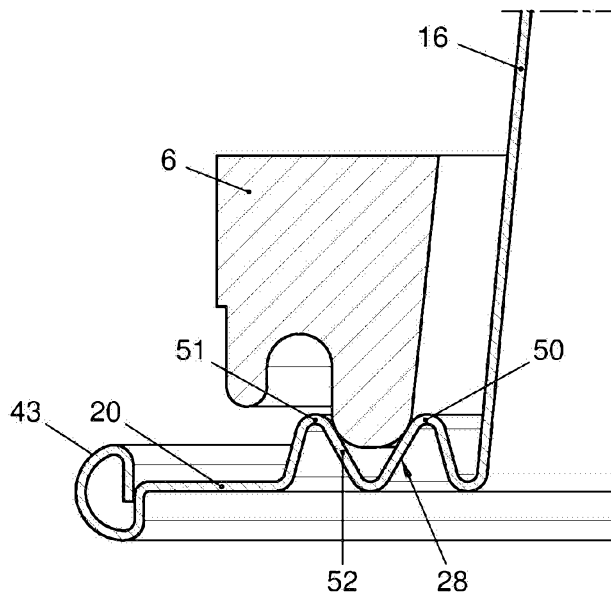

Fig. 4F

Fig. 4G

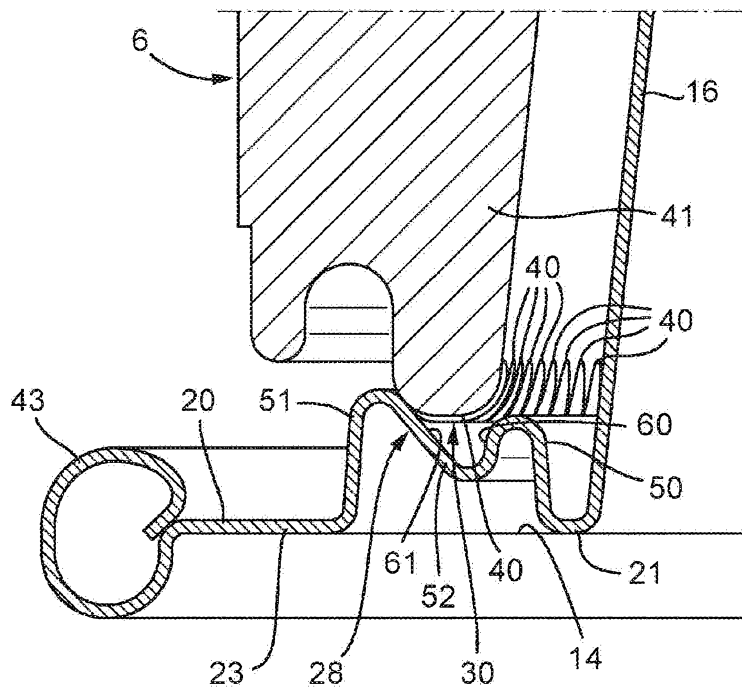

Fig. 5A

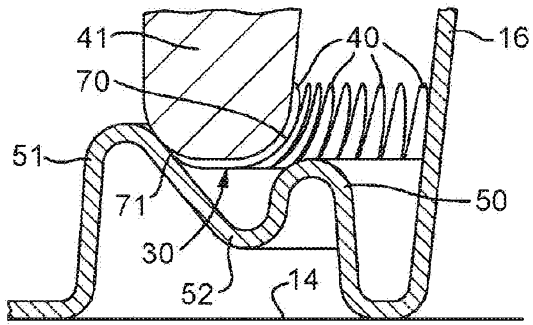

Fig. 5B

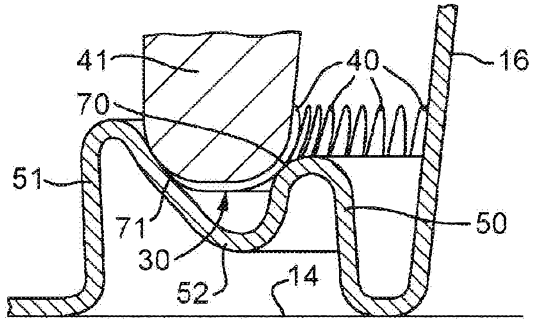

Fig. 5C

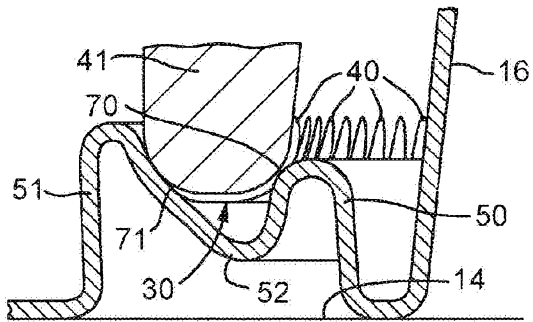

Fig. 5D

