

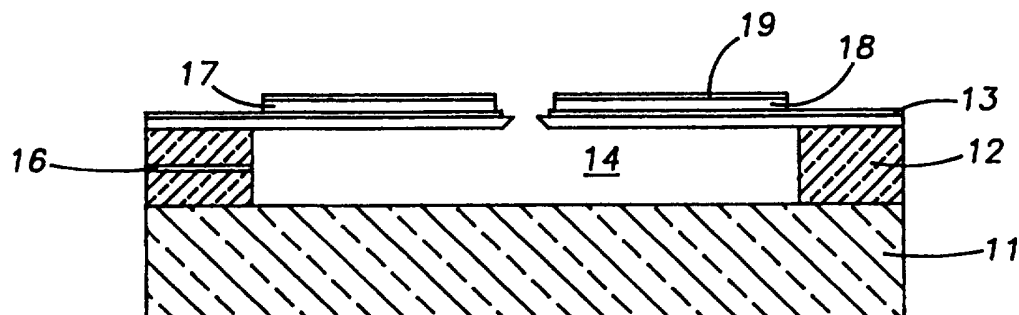

INTERNATIONAL APPLICATION PUBLISHED UNDER THE PATENT COOPERATION TREATY (PCT)

<p>(51) International Patent Classification ⁶ : B05B 17/06, B41J 2/025, 2/035, 2/04, 2/16</p>	A1	<p>(11) International Publication Number: WO 97/12689 (43) International Publication Date: 10 April 1997 (10.04.97)</p>
<p>(21) International Application Number: PCT/US96/14717 (22) International Filing Date: 11 September 1996 (11.09.96) (30) Priority Data: 08/530,919 20 September 1995 (20.09.95) US (71) Applicant: THE BOARD OF TRUSTEES OF THE LELAND STANFORD JUNIOR UNIVERSITY [US/US]; Suite 350, 900 Welch Road, Palo Alto, CA 94304 (US). (72) Inventors: KHURI-YAKUB, Brutus, Thomas; 4151 Donald Drive, Palo Alto, CA 94305 (US). LEVIN, Laurent; 71, rue Convention, F-75015 Paris (FR). (74) Agents: TEST, Aldo, J. et al.; Flehr, Hohbach, Test, Albritton & Herbert, 4 Embarcadero Center, Suite 3400, San Francisco, CA 94111-4187 (US).</p>		<p>(81) Designated States: JP, KR, European patent (AT, BE, CH, DE, DK, ES, FI, FR, GB, GR, IE, IT, LU, MC, NL, PT, SE). Published <i>With international search report. Before the expiration of the time limit for amending the claims and to be republished in the event of the receipt of amendments.</i></p>

(54) Title: FLUID DROP EJECTOR AND METHOD



(57) Abstract

An improved fluid drop ejector is disclosed which includes one wall comprising a thin elastic membrane (13) having an orifice defining a nozzle and means (17) responsive to electrical signals for deflecting the membrane to eject drops of fluid from said nozzle.

FOR THE PURPOSES OF INFORMATION ONLY

Codes used to identify States party to the PCT on the front pages of pamphlets publishing international applications under the PCT.

AM	Armenia	GB	United Kingdom	MW	Malawi
AT	Austria	GE	Georgia	MX	Mexico
AU	Australia	GN	Guinea	NE	Niger
BB	Barbados	GR	Greece	NL	Netherlands
BE	Belgium	HU	Hungary	NO	Norway
BG	Bulgaria	IE	Ireland	NZ	New Zealand
BF	Burkina Faso	IT	Italy	PL	Poland
BH	Benin	JP	Japan	PT	Portugal
BR	Brazil	KE	Kenya	RO	Romania
BY	Belarus	KG	Kyrgystan	RU	Russian Federation
CA	Canada	KP	Democratic People's Republic of Korea	SD	Sudan
CF	Central African Republic	KR	Republic of Korea	SE	Sweden
CG	Congo	KZ	Kazakhstan	SG	Singapore
CH	Switzerland	LI	Liechtenstein	SI	Slovenia
CI	Côte d'Ivoire	LK	Sri Lanka	SK	Slovakia
CM	Cameroon	LR	Liberia	SN	Senegal
CN	China	LT	Lithuania	SZ	Swaziland
CS	Czechoslovakia	LU	Luxembourg	TD	Chad
CZ	Czech Republic	LV	Latvia	TG	Togo
DE	Germany	MC	Monaco	TJ	Tajikistan
DK	Denmark	MD	Republic of Moldova	TT	Trinidad and Tobago
EE	Estonia	MG	Madagascar	UA	Ukraine
ES	Spain	ML	Mali	UG	Uganda
FI	Finland	MN	Mongolia	US	United States of America
FR	France	MR	Mauritania	UZ	Uzbekistan
GA	Gabon			VN	Viet Nam

FLUID DROP EJECTOR AND METHODBrief Summary of the Invention

This invention relates generally to fluid drop ejectors and method of operation, and more particularly to fluid drop
5 ejectors wherein the drop size, number of drops, speed of ejected drops, and ejection rate are controllable.

Background of the Invention

Fluid drop ejectors have been developed for inkjet printing. Nozzles which allow the formation and control of small ink
10 droplets permit high resolution, resulting in printing sharper characters and improved tonal resolution. Drop-on-demand inkjet printing heads are generally used for high-resolution printers.

In general, drop-on-demand technology uses some type of pulse generator to form and eject drops. In one example, a
15 chamber having an ink nozzle is fitted with a piezoelectric wall which is deformed when a voltage is applied. As a result, the fluid is forced out of the nozzle orifice and impinges directly on an associated printing surface. Another type of printer uses bubbles formed by heat pulses to force fluid out of the nozzle.
20 The drops are separated from the ink supply when the bubbles collapse.

There is a need for an improved fluid drop ejector for use not only in printing, but also, for photoresist deposition in the semiconductor and flat panel display industries, drug and
25 biological sample delivery, delivery of multiple chemicals for chemical reactions, DNA sequences, and delivery of drugs and biological materials for interaction studies and assaying, and a need for depositing thin and narrow layers of plastics for use as permanent and removable gaskets in micro-machines. There

is also need for a fluid ejector that can cover large areas with little or no mechanical scanning.

Objects and Summary of the Invention

5 It is an object of this invention to provide an improved fluid drop ejector.

It is another object of the invention to provide a fluid drop ejector in which the ejected fluid, drop size, drop velocity, ejection rate and number of drops can be easily controlled.

10 It is a further object of the invention to provide a fluid drop ejector which can be micro-machined.

It is another object of the invention to provide a fluid drop ejector which can be micro-machined to provide a selectively excitable matrix of membranes having nozzles for ejection of fluid drops.

15 It is a further object of the invention to provide a fluid drop ejector in which a membrane including a nozzle is actuated to eject droplets of fluid, at or away from the mechanical resonance of the membrane.

20 The foregoing and other objects are achieved by a fluid drop ejector which includes a fluid reservoir with one wall comprising a thin, elastic membrane having an orifice defining a nozzle. The membrane is adapted to mechanically vibrate on application of bending forces applied preferentially at its resonant frequency. When said reservoir contains fluid, the membrane deflects to form and eject drops at the nozzle. The reservoir is not necessarily full of fluid.

Brief Description of the Drawings

30 The foregoing and other objects of the invention will be more fully understood from the following description read in connection with the accompanying drawings, wherein:

Figure 1 is a sectional view of a drop-on-demand fluid drop ejector in accordance with the invention including a piezoelectrically driven membrane;

35 Figure 2 is a top plan view of the ejector shown in Figure 1;

Figure 3 is a sectional view of a drop-on-demand fluid drop ejector in accordance with another embodiment of the invention;

5 Figures 4A-4C show the ac voltage applied to the piezoelectric transducer of Figures 1 and 2, the mechanical oscillation of the membrane, and continuous ejection of fluid drops;

10 Figures 5A-5C show the application of ac voltage pulses to the piezoelectric transducer of Figures 1 and 2, the mechanical oscillation of the membrane and the drop-on-demand ejection of drops;

 Figures 6A-6C show the first three mechanical resonant modes of a membrane as examples among all the modes of superior order in accordance with the invention;

15 Figures 7A-7D show the deflection of the membrane responsive to the application of an excitation ac voltage;

 Figure 8 is a side elevational view of a fluid drop ejector wherein the membrane is electrostatically oscillated;

 Figure 9 shows another embodiment of an electrostatically oscillated membrane;

20 Figure 10 shows a fluid drop ejector in which the membrane is oscillated by a magnetic driver;

 Figures 11A-11D show the steps in the fabrication of a matrix of fluid drop ejectors of the type shown in Figures 1 and 2;

25 Figure 12 is a top plan view of a matrix fluid drop ejector formed in accordance with the process of Figures 11A-11D;

 Figures 13A-13C show the steps in the fabrication of a matrix of electrostatic fluid drop ejectors;

30 Figure 14 is a top plan view of the fluid drop ejector shown in Figure 12;

 Figure 15 is a bottom plan view of the fluid drop ejector shown in Figure 12; and

 Figure 16 shows another embodiment of a matrix fluid drop ejector.

35 Description of the Preferred Embodiments

 A fluid drop ejector according to one embodiment of this invention is shown in Figures 1 and 2. The ejector includes

a support body or substrate 11 which can have apertures for the supply of fluid. A cylindrical wall 12 supports an elastic membrane 13. The support 11, wall 12 and membrane 13 define a fluid reservoir 14. An aperture 16 may be formed in the wall
5 12 to permit continuous supply of fluid into the reservoir to replenish fluid which is ejected, as will be presently described. The supply opening could be formed in the support body or substrate 11 or its apertures. A piezoelectric annular disk
10 17 is attached to or formed on the upper surface of the membrane 13. The disk 17 includes conductive contact films 18 and 19. The piezoelectric film can also be formed on the bottom surface of the membrane, or can itself be the membrane.

In accordance with the invention, the membrane is driven so that it mechanically oscillates preferably into resonance.
15 This is illustrated in Figures 4 through 6. Figure 4A shows a sine wave excitation voltage which is applied to the piezoelectric transducer. The transducer applies forces to the membrane responsive to the applied voltage. Figure 4B shows the amplitude of deflection at the center of the membrane
20 responsive to the applied forces. It is noted that when the power is first applied, the membrane is only slightly deflected by the first power cycle, as shown at 22, Figure 4B. The deflection increases, whereby, in the present example, at the third cycle, the membrane is in maximum deflection, as shown
25 at 23, Figure 4B. At this point, its deflection cyclically continues at maximum deflection with the application of each cycle of the applied voltage, and permits the ejection of each corresponding drop, as shown in Figure 4C. When the power is
30 turned off, the membrane deflection decays as shown at 24, Figure 4B. The frequency at which the membrane resonates is dependent on the membrane material, its elasticity, thickness, shape and size. The shape of the membrane is preferentially circular; however, the other shapes, such as square, rectangular, etc., can be made to resonate and eject fluid drops. In particular,
35 an elliptic membrane can eject two drops from its focal points at resonance. The amount of deflection depends on the magnitude of the applied power. Figure 6 shows, for a circular membrane, that the membrane may have different modes of resonant

deflection. Figure 6A shows deflection at its fundamental frequency; Figure 6B at the first harmonic and Figure 6C at the second harmonic.

5 The action of the membrane to eject drops of fluid is illustrated in Figures 7A-7D. These figures represent the deflection at the fundamental resonance frequency. Figure 7A shows the membrane deflected out of the reservoir, with the liquid in contact with the membrane. Figure 7B shows the membrane returning to its undeflected position, and forming an elongated bulb of fluid 26 at the orifice nozzle. Figure 7C shows the membrane extending into the reservoir and achieving sufficient velocity for the bulb to cause it to break away from the body of fluid 26 and form a drop 27 which travels in a straight line away from the membrane and nozzle toward an associated surface such as a printing surface. Figure 7D represents the end of the cycle and the shape of the fluid bulb at that point.

Referring to Figure 4C, it is seen that the membrane reaches maximum deflection upon application of the third cycle of the applied voltage. It then ejects drops with each cycle of the applied voltage as long as the applied voltage continues. Figures 5A-5C show the application of excitation pulses. At 29, Figure 5A, a four-cycle pulse is shown applied, causing maximum deflection and ejection of two single drops. The oscillation then decays and no additional drops are ejected. At 30, three cycles of power are applied, ejecting one drop. It is apparent that drops can be produced on demand. The drop rate is equal to the frequency of the applied excitation voltage. The drop size is dependent on the size of the orifice and the magnitude of the applied voltage. The fluid is preferably fed into the reservoir at constant pressure to maintain the meniscus of the fluid at the orifice in a constant concave, flat, or convex shape, as desired. The fluid must not contain any air bubbles, since it would interfere with operation of the ejector.

35 Figure 3 shows a fluid drop ejector which has an open reservoir 14a. The weight of the fluid keeps it in contact with the membrane. The bulb 26a is ejected due to the suppression caused by deflection of the membrane 13 into the fluid.

A fluid drop ejector of the type shown in Figure 3 was constructed and tested. More particularly, the resonant membrane comprised a circular membrane of steel (0.05 mm in thickness; 25 mm in diameter, having a central hole of 150 μ m in diameter). This membrane was supported by a housing composed of a brass cylinder with an outside diameter of 25 mm and an inside diameter of 22.5 mm. The membrane was actuated by an annular piezoelectric plate bonded on its bottom and on axis to the circular membrane. The annular piezoelectric plate had an outside diameter of 23.5 mm and an inside diameter of 18.8 mm. Its thickness was 0.5 mm. The reservoir was formed by the walls of the housing and the top was left open to permit refilling with fluid. The device so constructed ejected drops of approximately 150 μ m in diameter. The ejection occurred when applying an alternative voltage of 15 V peak to the piezoelectric plate at a frequency of 15.5 KHz (with 0.3 KHz tolerance of bandwidth), which corresponded to the resonant frequency of the liquid loaded membrane. This provided a bending motion of the membrane with large displacements at the center. Thousands of identical drops were ejected in one second with the same direction and velocity. The level of liquid varied from 1-5 mm with continuous ejection while applying a slight change in frequency to adapt to the change in the resonant frequency of the composite membrane due to different liquid loading. When the level of liquid remained constant, the frequency of drop formation remained relatively constant. The excitation was sinusoidal, although square waves and triangular waveforms were used as harmonic signals and also gave continuous drop ejection as the piezoelectric material was excited.

As will be presently described, the fluid drop ejector can be implemented using micro-machining technologies of semiconductor materials. The housing could be silicon and silicon oxide, the membrane could be silicon nitride, and the piezoelectric could be a deposited thin film such as zinc oxide. In this manner, the dimensions of an ejector could be no more than 100 microns and the orifice could be anywhere from a few to tens of microns. Two-dimensional matrices can be easily implemented for printing at high speed with little or no relative

motion between the fluid drop ejector and object upon which the fluid is to be deposited.

The membrane can be excited into resonance with other types of drivers. For example, Figure 7 shows an ejector in which the membrane is electrostatically vibrated. The membrane 31 may be of silicon nitride with a conductive film 32. The membrane is spaced from the substrate 33 by an insulating oxide ring 34; a conductive film 36 is applied to the lower surface of the substrate. Thus, when voltage is applied between the two conductive films, it induces a force proportional to the square of the electric field between the two conductive films 32, 36. The added simplicity of not needing a piezoelectric transducer is quite important; however, such a design will only work for fluids that are non-conductive. Micro-machining such a device will be described below.

Figure 9 shows an electrostatic fluid drop ejector which can be used to eject conductive fluids. The same reference numbers have been applied to parts corresponding to Figure 8. The fluid drop ejector of Figure 9 includes an insulating support 37 which supports a rigid conductive member 38 spaced from the film 32. Voltage applied between the conductive member 37 and conductive film 32 will give rise to forces proportional to the square of the electric field therebetween. These forces will serve to deflect the membrane 31.

Figure 10 illustrates a device similar to that of Figures 8 and 9, where like reference numbers have been applied to like parts. However, the transducer 39 is a magnetic transducer electrically driven to deflect and bring into resonance the membrane 31. This transducer can also be driven magnetically or electrically by another transducer placed at a distance such as behind a piece of paper.

Referring to Figures 11A-11D, the steps of forming a micro-machined matrix of fluid drop ejectors of the type shown in Figures 1 and 2 from semiconductor material are shown. By well-known semiconductor film or layer-growing techniques, a silicon substrate 41 is provided with successive layers of silicon oxide 42, silicon nitride 43, metal 44, piezoelectric material 45 and metal 46. The next steps, shown in Figure 11B, are to mask and

etch the metal film 46 to form disk-shaped contacts 48 having a central aperture 49 and interconnected along a line. The next step is to etch the piezoelectric layer in the same pattern to form transducers 51. The next step is to mask and etch the film
5 44 to form disk-shaped contacts 52 having central apertures 53 and interconnected along columns 55, Figure 12. The next steps, Figure 11D, are to mask and etch orifices 54 in the silicon nitride layer 43. This is followed by selectively etching the silicon oxide layer 42 through the orifices 54 to form a fluid
10 reservoir 56. The silicon nitride membrane is supported by silicon oxide posts 57.

Figure 12 is a top plan view of the matrix shown in Figures 11A-11D. The dotted outline shows the extent of the fluid reservoir. It is seen that the membrane is supported by the
15 spaced posts 57. The lower contacts of the piezoelectric members in the horizontal rows are interconnected as shown and the upper contacts of the piezoelectric members in the columns are interconnected as shown, thereby giving a matrix in which the individual ejectors can be excited, thereby ejecting selected
20 patterns of drops. By micro-machining, closely spaced patterns of orifices or nozzles can be achieved. If the spacing between orifices is 100 μm , the matrix will be capable of simultaneously depositing a resolution of 254 dots per inch. If the spacing between orifices is 50 μm , the matrix will be capable of
25 simultaneously depositing a resolution of 508 dots per inch. Such resolution would be sufficient to permit the printing of lines or pages of text without the necessity of relative movement between the print head and the printing surface.

The steps of forming a matrix, including electrostatic excited fluid drop ejectors of the type shown in Figure 9, are
30 illustrated in Figures 13A-13C. The first step is to start with the highly doped polysilicon wafer 61 which serves as the substrate. The next steps are to grow a thick layer (1-10 μm) of oxide 62 thermally or by chemical vapor deposition or any other IC processing method, followed by the deposition of a 7500
35 Å-thick layer of low-stress LPCVD silicon nitride 63. The back side of the wafer is stripped of these layers and a 500 Å film of gold 64 is evaporated on both sides of the wafer. The

5 resulting structure is shown in Figure 13A. A resist pattern
of 2 μm diameter dots on a two-dimensional grid with 100 μm
period is transferred lithographically to the wafer. The gold
and nitride are etched through the dots by using a suitable
10 chemical etch for the gold and a plasma etch for the nitride.
The resulting structure is shown in Figure 13B. The holes 66
provide access to silicon dioxide which acts as a sacrificial
layer. The sacrificial layer is etched away by pure hydrofluoric
acid during a timed etch. This leaves a portion 67 of the
15 thermal oxide layer supporting the silicon nitride membrane.
The size of the unsupported silicon nitride membrane is
controlled by the etch time. However, if processing were termi-
nated at this point, the surface tension between the liquid
etchant and the silicon nitride layer would pull the nitride
20 membrane down as the etchant is removed. Once the nitride and
silicon are in contact, Vander Wals forces would hold the
membrane to the silicon substrate and the device would no longer
function. Two different techniques can be employed to prevent
this from occurring. First, chemically roughening the silicon
25 surface to reduce the surface area to which the membrane is
exposed and thus, reduce the Vander Wals forces holding the
membrane. The preferred chemical etchant is potassium hydroxide
and is an anisotropic silicon etchant. After 20 minutes of
etching, pyramidal posts are left on the silicon surface. The
30 second step used for preventing sticking is to freeze-dry the
structure; this results in the liquid etch sublimating instead
of evaporating. The patterned upper metal film is interconnected
along rows as shown in Figure 14 and the bottom film is patterned
and interconnected in columns as shown in Figure 15. This
provides a means for individually addressing the individual fluid
drop ejectors to electrostatically eject a dot pattern.

35 The invention has been described in connection with the
ejection of a single fluid as, for example, for printing a single
color or delivering a single biological material or chemical.
It is apparent that ejectors can be formed for ejecting two or
more fluids for color printing and chemical or biological
reactions. The spacing of the apertures and the size and
location of the associated membranes can be selected to provide

isolated columns or rows of interconnected reservoirs. Adjacent rows or columns can be provided with different fluids. An example of a matrix of fluid ejectors having isolated rows of fluid reservoirs is shown in Figure 16. The fluid reservoirs 56a are interconnected along rows 71. The rows are isolated from one another by the walls 57a. Thus, each of the rows of reservoirs can be supplied with a different fluid. Individual ejectors are energized by applying voltages to the interconnections 58a and 59a. The illustrated embodiment is formed in the same manner as the embodiment of Figure 12. It is apparent that spacing of apertures and reservoirs of the embodiment of Figures 14 and 15 can be controlled to form isolated rows or columns of reservoirs and apertures to provide for delivery of multiple fluids. The processing of the fluid drop ejector assembly of Figures 14 and 15 can be controlled so that there are individual fluid reservoirs with individual isolated membranes.

WHAT IS CLAIMED:

1. A fluid drop ejector comprising:
at least one fluid reservoir,
at least one elastic membrane having at least one orifice
5 defining at least one nozzle adapted to be in contact with a
fluid in said reservoir,
displacement means responsive to an applied electrical
signal for displacing said at least one membrane to bring said
at least one membrane into mechanical oscillation whereby, when
10 the fluid is in contact with said at least one membrane, the
displacement of the membrane causes the formation and ejection
of a drop of fluid from said at least one nozzle with each cycle
of oscillation.
2. A fluid drop ejector as in Claim 1 wherein the means for
15 displacing said at least one membrane comprises a piezoelectric
transducer affixed to said at least one membrane.
3. A fluid drop ejector as in Claim 1 wherein the means for
displacing said at least one membrane comprises an
electromagnetic transducer affixed to said at least one membrane.
- 20 4. A fluid drop ejector as in Claim 1 wherein the means for
displacing said at least one membrane comprises a conductive
film on the surface of said membrane and a spaced conductor
whereby application of the ac electrical signal between the film
and spaced conductor generates an electrostatic force which
25 deflects said at least one membrane.
5. A fluid drop ejector as in Claim 1 which comprises a
plurality of elastic membranes in contact with said at least
one fluid reservoir, each including displacement means for
applying ac electrical signals to each of said displacement means
30 to eject drops from selected membranes.
6. A fluid drop ejector as in Claim 5 wherein said at least
one fluid reservoir comprises at least two adjacent fluid

- reservoirs and said at least one elastic membrane includes at least one membrane in contact with fluid in each of said reservoirs, whereby fluids can be selectively ejected from each said reservoir.
- 5 7. A fluid drop ejector as in Claim 6 wherein said fluid reservoirs are elongated, and a plurality of membranes are in line along each of said reservoirs.
8. A fluid drop ejector as in Claim 5 wherein said ejector includes a plurality of elastic membranes arranged in a matrix.
- 10 9. A fluid drop ejector which includes:
a substrate,
a matrix of elastic membranes, each including at least one aperture,
a support structure for supporting the membranes on said
15 substrate and defining at least one fluid reservoir for receiving a fluid,
means for supplying fluid to said fluid reservoir, and
displacement means responsive to an applied electrical
signal for selectively displacing said membranes to cause
20 formation and ejection of drops of fluid from said reservoir.
10. A fluid drop ejector as in Claim 9 wherein the means for displacing said membranes comprises piezoelectric transducers affixed to each of said membranes.
- 25 11. A fluid drop ejector as in Claim 9 wherein the means for displacing said membranes comprises electromagnetic transducers affixed to each of said membranes.
- 30 12. A fluid drop ejector as in Claim 9 wherein the means for displacing said membranes comprises a conductive film on the surface of each of said membranes and a spaced conductor whereby application of the ac electrical signal between the film and spaced conductor generates an electrostatic force which deflects said membranes.

13. A fluid drop ejector as in Claim 9 wherein said support structure defines a plurality of fluid reservoirs whereby each reservoir can receive a different fluid.

- 5 14. The method of fabricating a fluid drop ejector comprising the steps of:
- providing a substrate;
 - forming a support layer on said substrate;
 - forming a membrane layer of material on said support layer;
 - forming apertures in said membrane layer to expose said
- 10 support layer; and
- etching away portions of said support layer to leave unsupported membrane spaced from said substrate to define therewith a fluid reservoir.

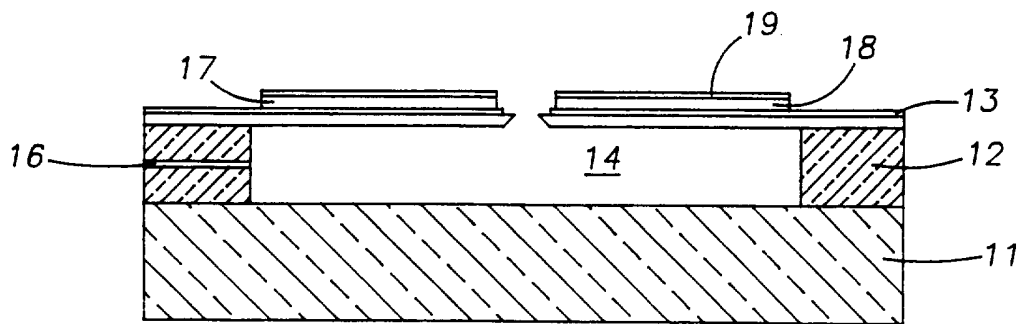

FIG. - 1

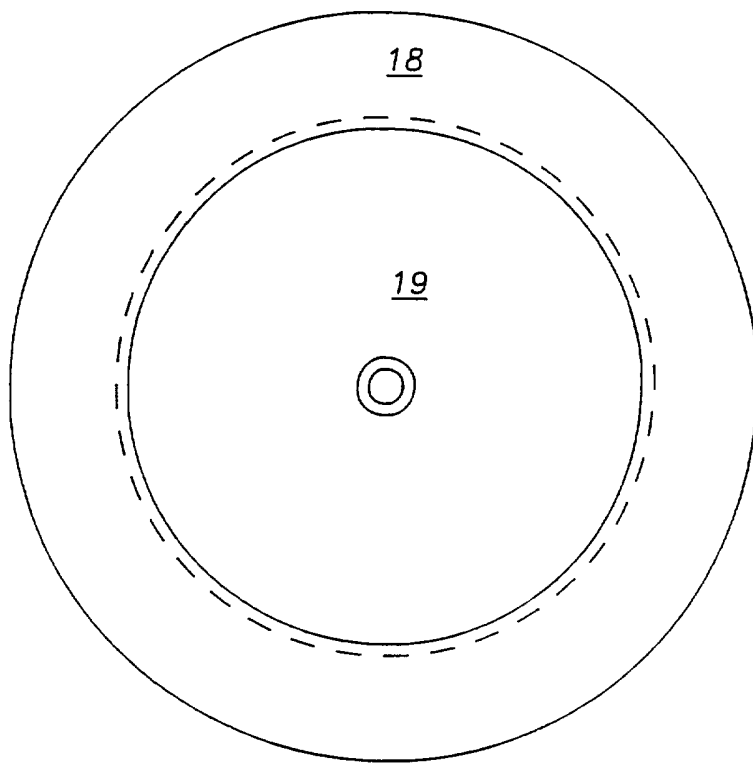

FIG. - 2

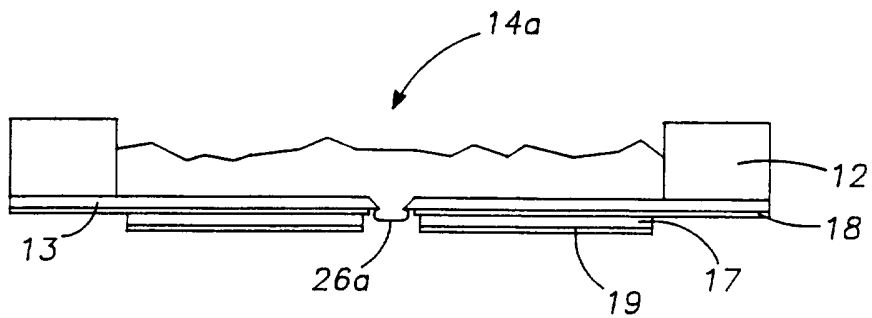

FIG. - 3

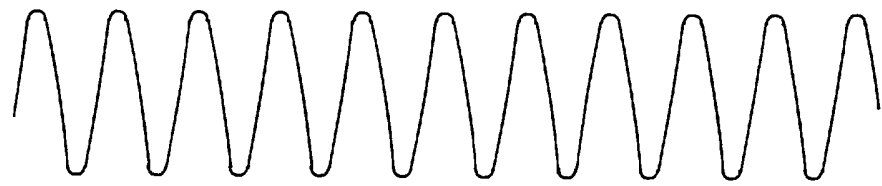

FIG. - 4A

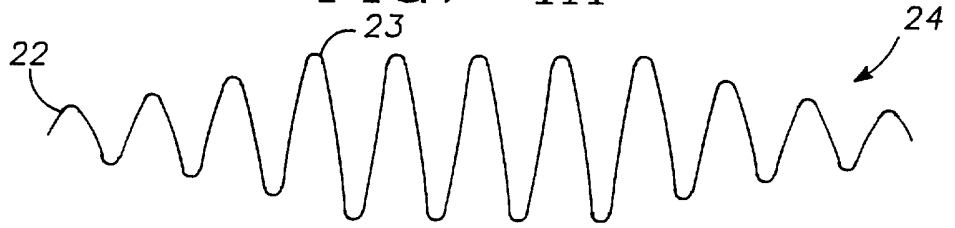

FIG. - 4B

• • • • •

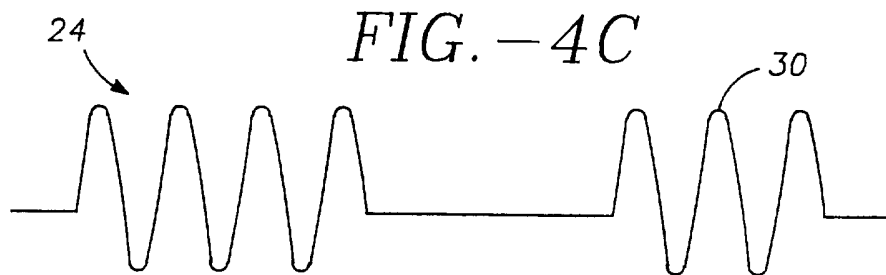

FIG. - 4C

FIG. - 5A

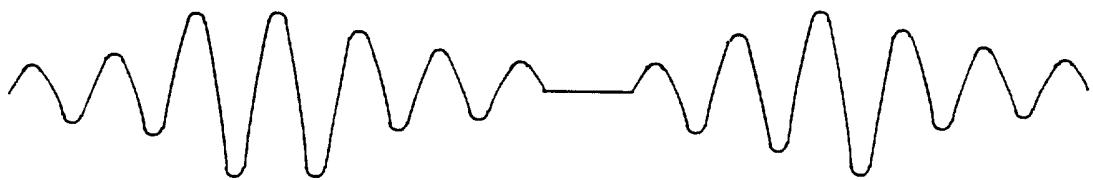

FIG. - 5B

• •

•

FIG. - 5C



FIG. - 6A

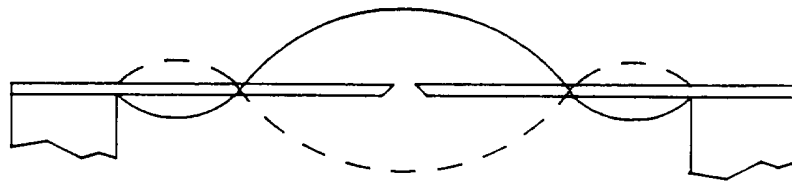

FIG. - 6B

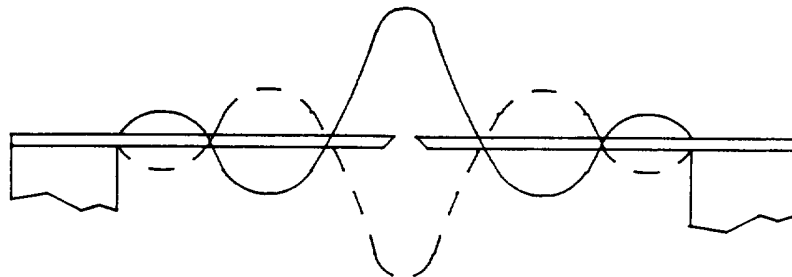

FIG. - 6C

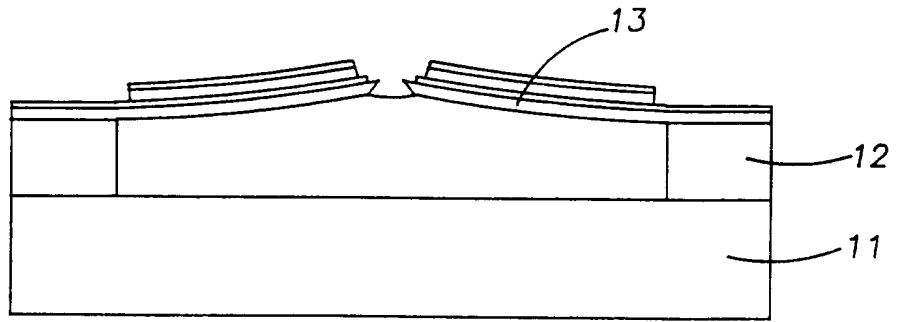

FIG. - 7A

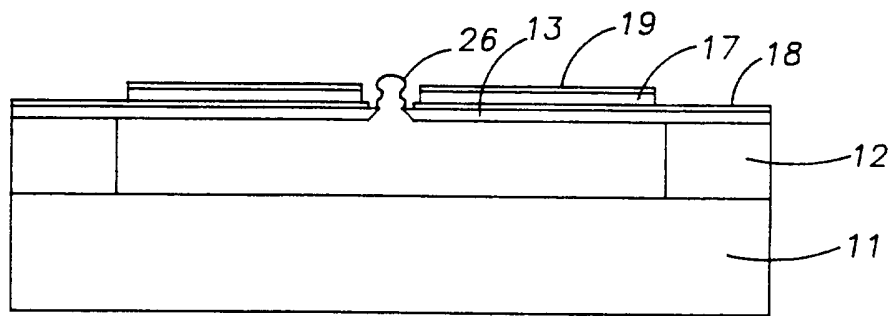

FIG. - 7B

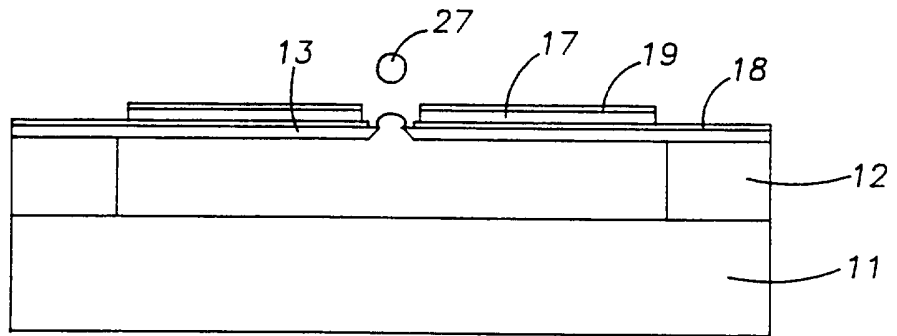

FIG. - 7C

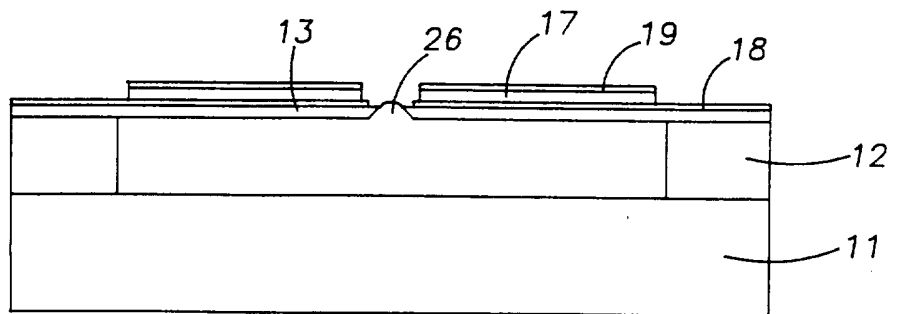

FIG. - 7D

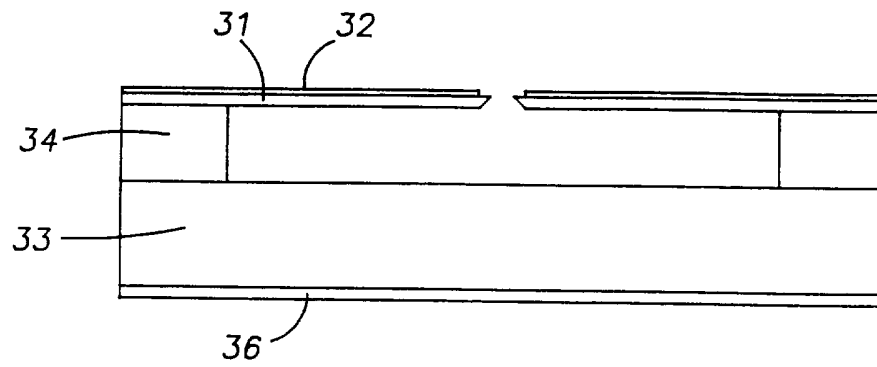

FIG. - 8

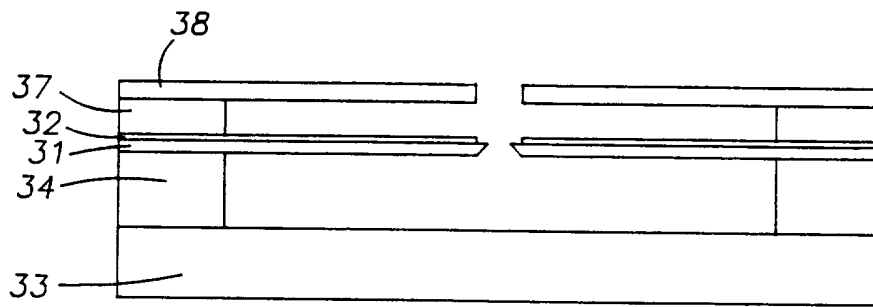

FIG. - 9

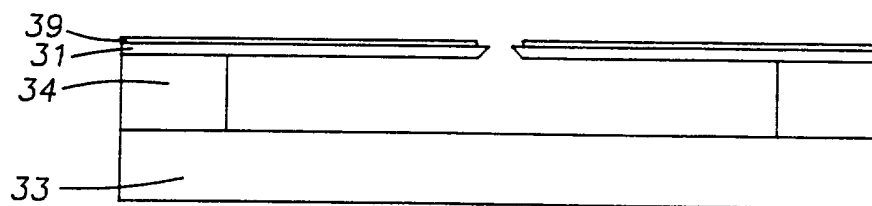

FIG. - 10

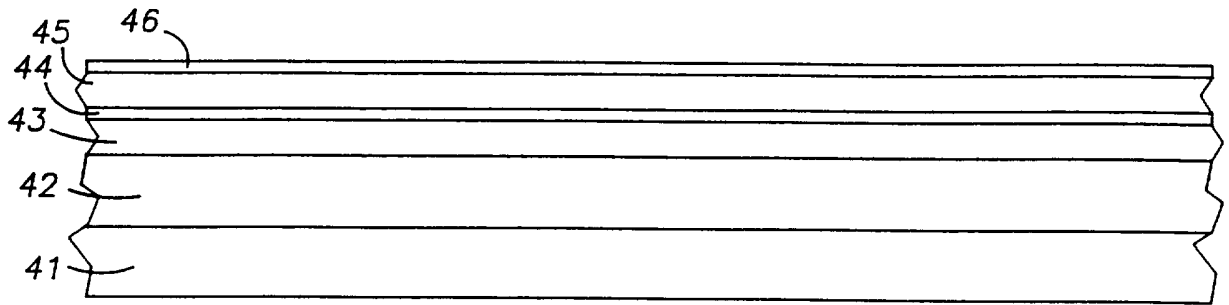

FIG. - 11A

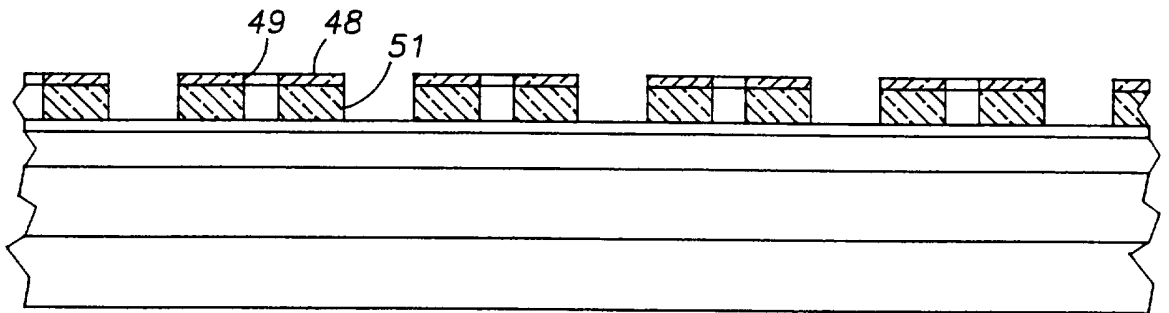

FIG. - 11B

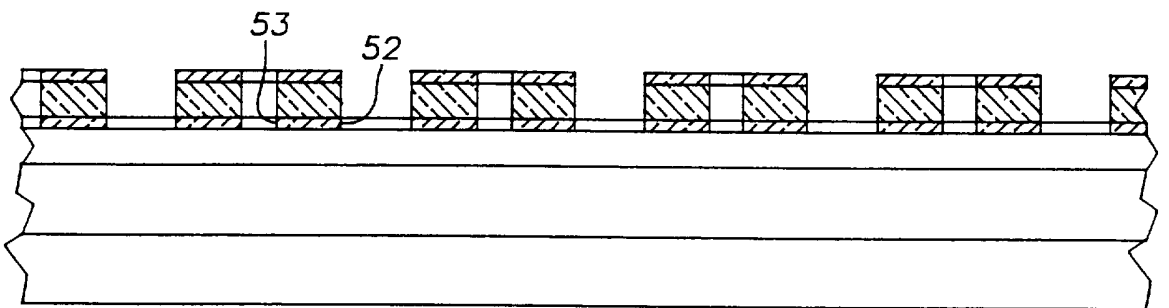

FIG. - 11C

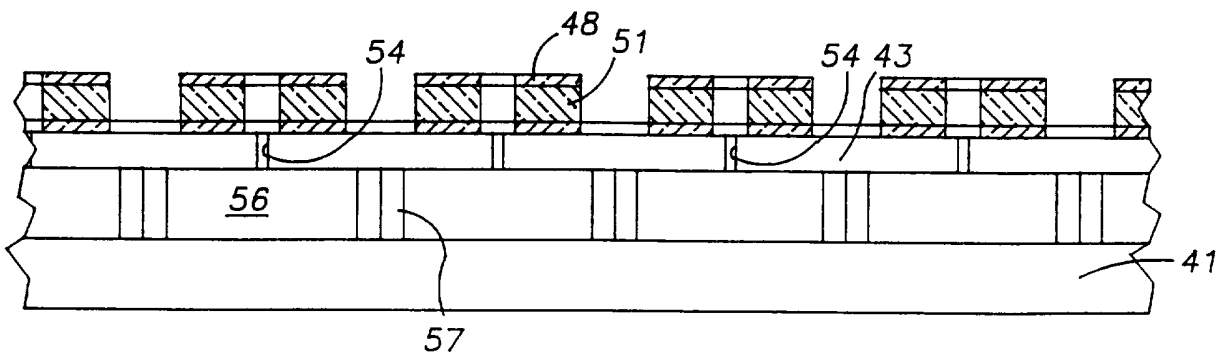

FIG. - 11D

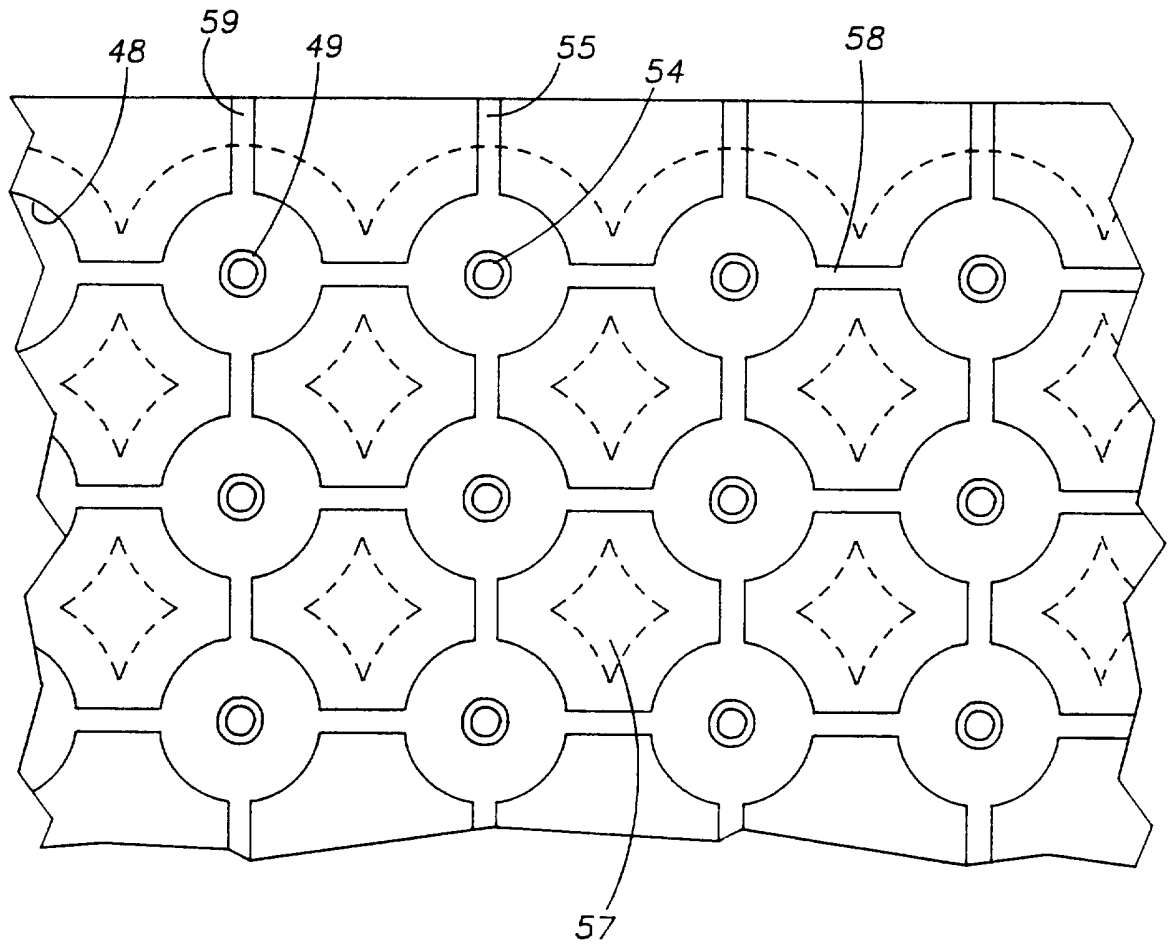

FIG. - 12

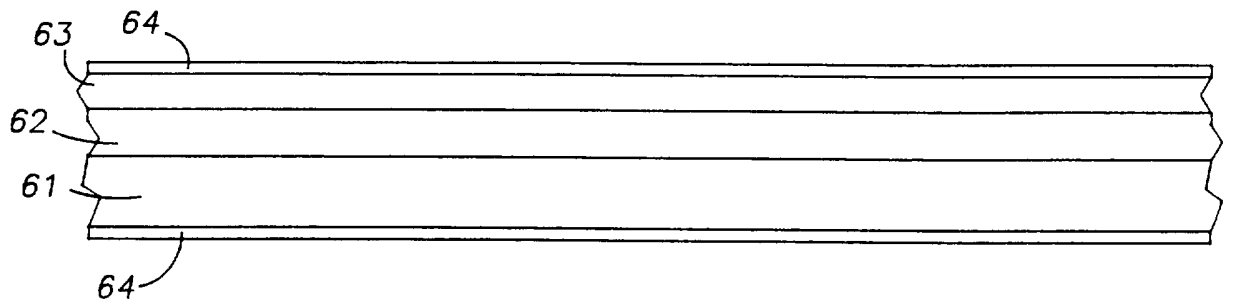

FIG. - 13A

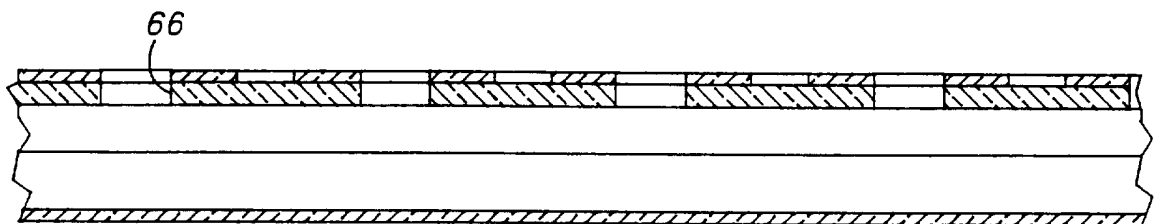

FIG. - 13B

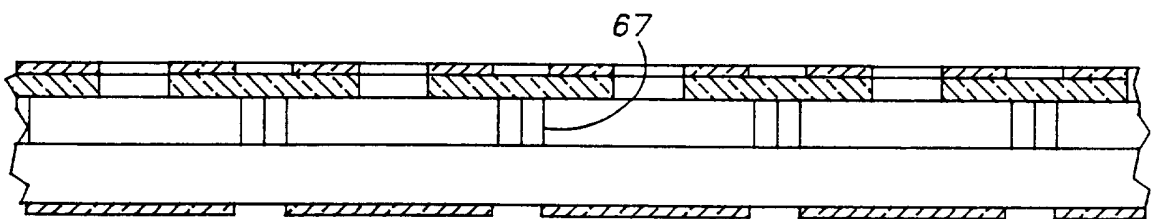

FIG. - 13C

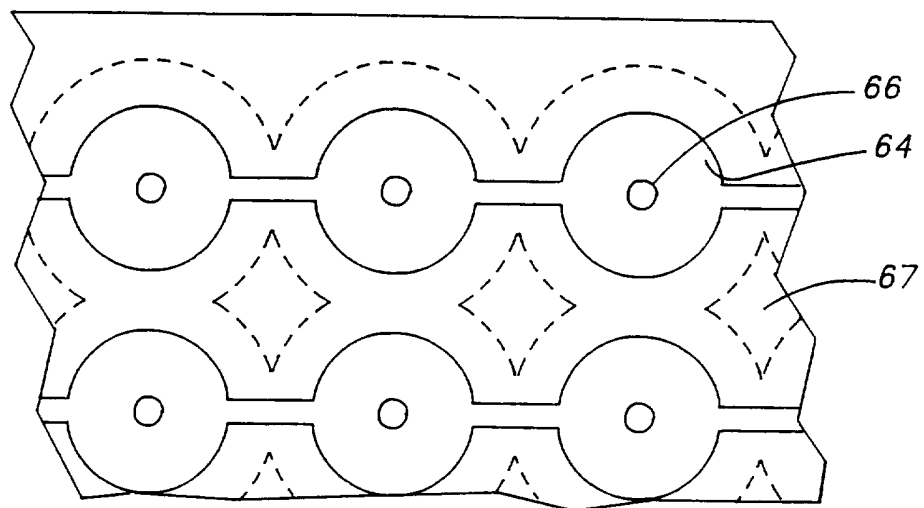

FIG. - 14

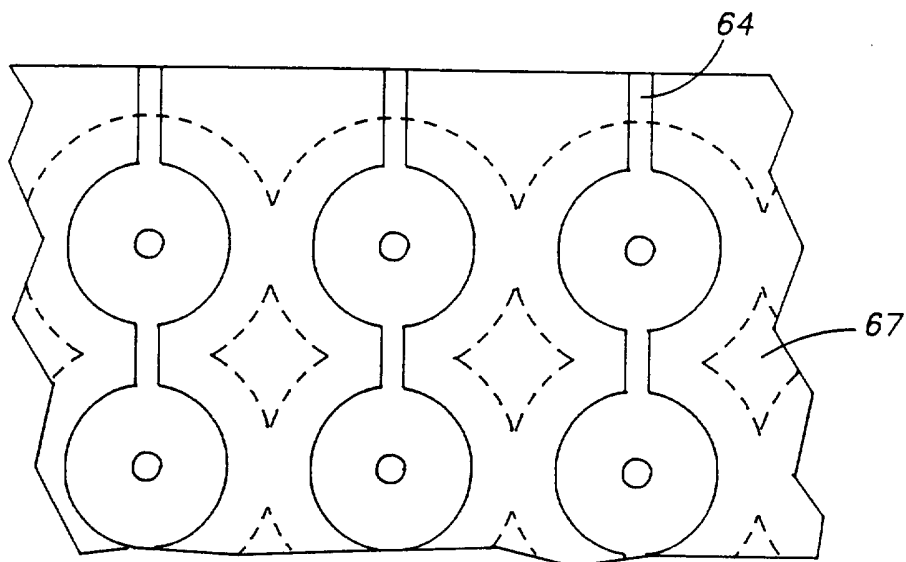

FIG. - 15

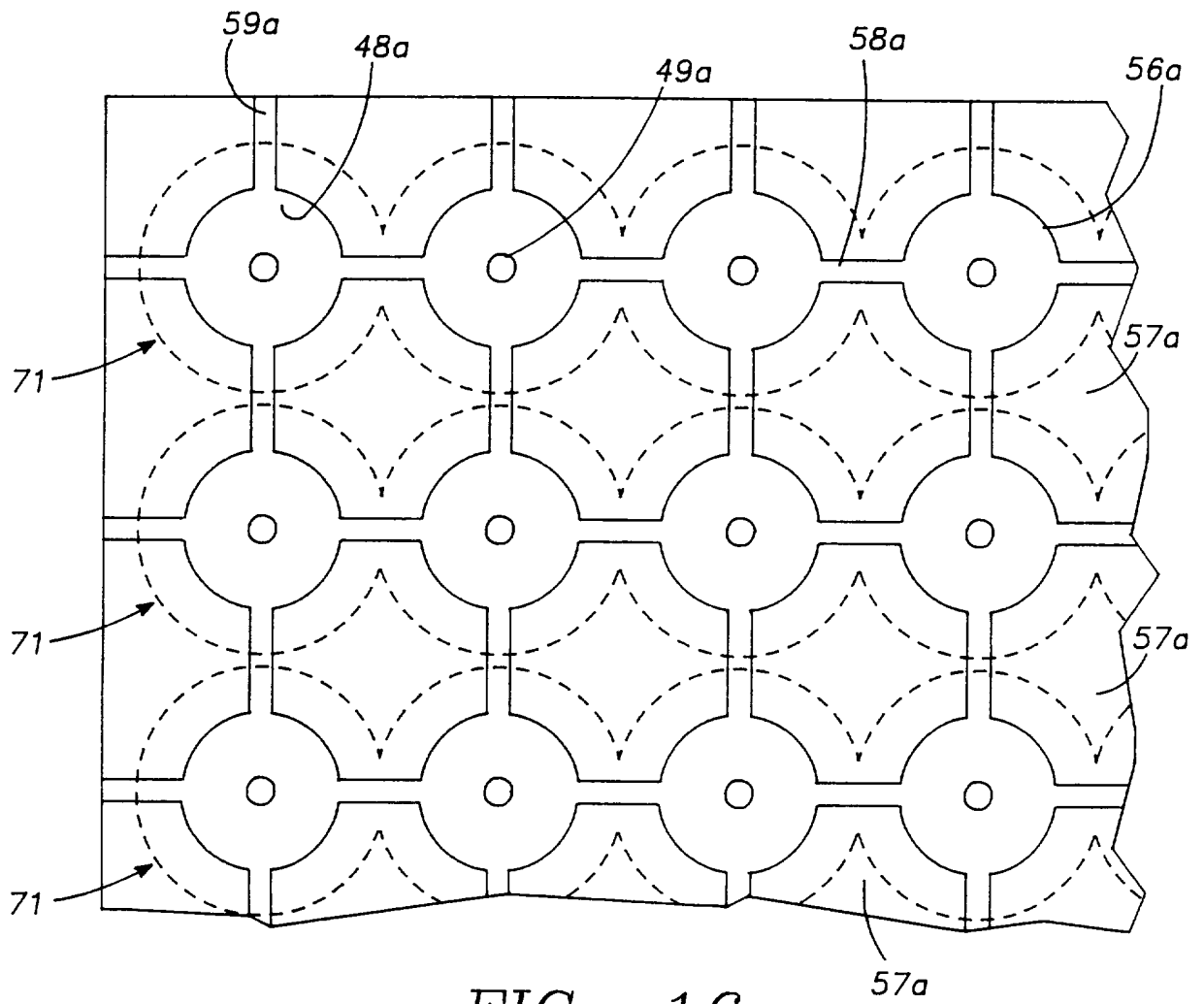

FIG. - 16

INTERNATIONAL SEARCH REPORT

International Application No
PCT/US 96/14717

A. CLASSIFICATION OF SUBJECT MATTER
 IPC 6 B05B17/06 B41J2/025 B41J2/035 B41J2/04 B41J2/16

According to International Patent Classification (IPC) or to both national classification and IPC

B. FIELDS SEARCHED
 Minimum documentation searched (classification system followed by classification symbols)
 IPC 6 B05B B41J G01D

Documentation searched other than minimum documentation to the extent that such documents are included in the fields searched

Electronic data base consulted during the international search (name of data base and, where practical, search terms used)

C. DOCUMENTS CONSIDERED TO BE RELEVANT

Category *	Citation of document, with indication, where appropriate, of the relevant passages	Relevant to claim No.
X	EP 0 077 636 A (MATSUSHITA ELECTRIC IND CO LTD) 27 April 1983	1,2
Y	see the whole document	3
Y	--- WO 93 10910 A (TECHNOLOGY PARTNERSHIP) 10 June 1993	3
A	see page 8, line 19 - page 10, line 29; claims 1,2,4,9	1,2
X	--- WO 93 01404 A (IVRI YEHUDA) 21 January 1993	1,2
A	see the whole document	3,4
	--- -/--	

Further documents are listed in the continuation of box C. Patent family members are listed in annex.

* Special categories of cited documents :

<p>*A* document defining the general state of the art which is not considered to be of particular relevance</p> <p>*E* earlier document but published on or after the international filing date</p> <p>*L* document which may throw doubts on priority claim(s) or which is cited to establish the publication date of another citation or other special reason (as specified)</p> <p>*O* document referring to an oral disclosure, use, exhibition or other means</p> <p>*P* document published prior to the international filing date but later than the priority date claimed</p>	<p>*T* later document published after the international filing date or priority date and not in conflict with the application but cited to understand the principle or theory underlying the invention</p> <p>*X* document of particular relevance; the claimed invention cannot be considered novel or cannot be considered to involve an inventive step when the document is taken alone</p> <p>*Y* document of particular relevance; the claimed invention cannot be considered to involve an inventive step when the document is combined with one or more other such documents, such combination being obvious to a person skilled in the art.</p> <p>* & * document member of the same patent family</p>
--	--

Date of the actual completion of the international search 6 December 1996	Date of mailing of the international search report 18.03.97
--	---

Name and mailing address of the ISA European Patent Office, P.B. 5818 Patentlaan 2 NL - 2280 HV Rijswijk Tel. (+ 31-70) 340-2040, Tx. 31 651 epo nl, Fax (+ 31-70) 340-3016	Authorized officer Nielsen, M
---	--------------------------------------

INTERNATIONAL SEARCH REPORT

International Application No
PCT/US 96/14717

C.(Continuation) DOCUMENTS CONSIDERED TO BE RELEVANT		
Category *	Citation of document, with indication, where appropriate, of the relevant passages	Relevant to claim No.
X	<p>WO 92 11050 A (MINNESOTA MINING & MFG) 9 July 1992 see abstract see page 5, line 12-26 see page 7, line 4 - page 8, line 7 see page 28, line 16-33 see page 31, line 9 - page 32, line 28; figures 17,20,21</p> <p style="text-align: center;">---</p>	1-3
X	<p>US 4 702 418 A (CARTER ROBERT E ET AL) 27 October 1987 see the whole document</p> <p style="text-align: center;">---</p>	1
X	<p>PATENT ABSTRACTS OF JAPAN vol. 008, no. 182 (M-319), 22 August 1984 & JP 59 073963 A (FUJI XEROX KK), 26 April 1984, see abstract</p> <p style="text-align: center;">---</p>	1,2
X	<p>PATENT ABSTRACTS OF JAPAN vol. 009, no. 200 (C-298), 16 August 1985 & JP 60 068071 A (MATSUSHITA DENKI SANGYO KK), 18 April 1985, see abstract</p> <p style="text-align: center;">---</p>	1,2
X	<p>PATENT ABSTRACTS OF JAPAN vol. 011, no. 213 (M-605), 10 July 1987 & JP 62 030048 A (SEIKO EPSON CORP), 9 February 1987, see abstract</p> <p style="text-align: center;">---</p>	1,2
X	<p>EP 0 542 723 A (BESPAK PLC) 19 May 1993 see abstract; figures 3-10</p> <p style="text-align: center;">-----</p>	1

INTERNATIONAL SEARCH REPORT

Information on patent family members

International Application No PCT/US 96/14717

Patent document cited in search report	Publication date	Patent family member(s)	Publication date
EP 0077636 A	27-04-83	JP 1479263 C JP 58122070 A JP 63027065 B JP 58067374 A AU 553251 B AU 8924482 A CA 1206995 A US 4533082 A	10-02-89 20-07-83 01-06-88 21-04-83 10-07-86 21-04-83 01-07-86 06-08-85

WO 9310910 A	10-06-93	AT 131421 T AU 665222 B AU 3090292 A DE 69206824 D DE 69206824 T EP 0615470 A JP 7501481 T US 5518179 A	15-12-95 21-12-95 28-06-93 25-01-96 23-05-96 21-09-94 16-02-95 21-05-96

WO 9301404 A	21-01-93	NONE	

WO 9211050 A	09-07-92	AU 9089591 A EP 0563120 A NZ 241034 A US 5487378 A	22-07-92 06-10-93 28-03-95 30-01-96

US 4702418 A	27-10-87	NONE	

EP 0542723 A	19-05-93	AT 143295 T AU 637658 B AU 6789790 A CA 2031907 A CN 1054916 A,B DE 69002926 D DE 69002926 T DE 69028718 D DE 69028718 T EP 0432992 A EP 0718046 A ES 2043293 T ES 2092146 T	15-10-96 03-06-93 23-07-92 13-06-91 02-10-91 30-09-93 23-12-93 31-10-96 06-02-97 19-06-91 26-06-96 16-12-93 16-11-96

INTERNATIONAL SEARCH REPORT

(Information on patent family members)

International Application No

PCT/US 96/14717

Patent document cited in search report	Publication date	Patent family member(s)	Publication date
EP 0542723 A		FR 2655572 A	14-06-91
		GB 2240494 A,B	07-08-91
		GB 2263076 A,B	14-07-93
		IE 69858 B	16-10-96
		IL 96597 A	12-04-94
		IT 1244181 B	08-07-94
		JP 4100557 A	02-04-92
		JP 6040984 B	01-06-94
		NO 179275 B	03-06-96
		RU 2051755 C	10-01-96
		US 5152456 A	06-10-92
		US 5261601 A	16-11-93
