

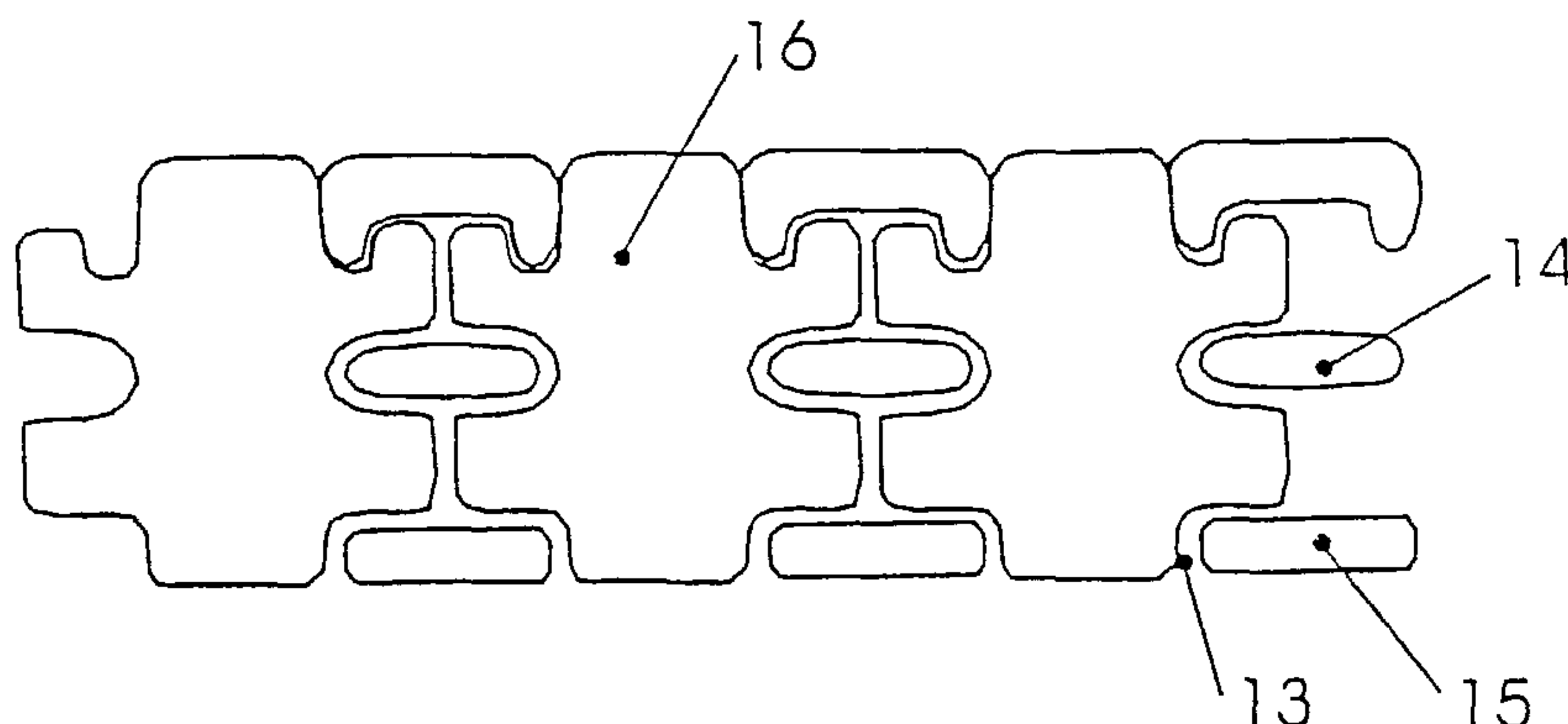

(86) Date de dépôt PCT/PCT Filing Date: 2001/04/11
 (87) Date publication PCT/PCT Publication Date: 2001/11/01
 (85) Entrée phase nationale/National Entry: 2002/09/10
 (86) N° demande PCT/PCT Application No.: DK 2001/000262
 (87) N° publication PCT/PCT Publication No.: 2001/081809
 (30) Priorités/Priorities: 2000/04/25 (PA 2000 00672) DK;
 2000/11/15 (PA 2000 01707) DK

(51) Cl.Int.⁷/Int.Cl.⁷ F16L 11/16
 (71) Demandeur/Applicant:
 NKT FLEXIBLES I/S, DK
 (72) Inventeurs/Inventors:
 GLEJBOL, KRISTIAN, DK;
 WEDEL-HEINEN, JAKOB, DK;
 RYTTER, JAN CHRISTIAN, DK
 (74) Agent: FETHERSTONHAUGH & CO.

(54) Titre : TUYAU FLEXIBLE ARME ET SON UTILISATION
 (54) Title: ARMoured, FLEXIBLE PIPE AND USE OF SAME



(57) **Abrégé/Abstract:**

A flexible armoured pipe, which comprises an inner liner, which is surrounded by a pressure armour, is built up by the joining together of profiles, which have a number of recesses. According to the invention, the profiles are configured as K-profiles (10, 16, 17), which have recesses (10a, 10b, 10c, 10d), which are arranged in adjoining surfaces of the profile. When the profiles are brought together, the recesses form a cavity in which a locking element (12, 14, 18) can be inserted, the function of which is to prevent displacement of the K-profiles at right-angles to the axial direction of the pipe when this is exposed to axial, compressive forces. The locking element can be I-shaped (14), be circular or be configured as a wire (18) with a C-shaped cross-section. The locking element can also be made either of a rigid or an elastic, deformable material. With a C-shaped locking element, the whole of the cavity, which is formed by the recesses, is not filled out. A channel is hereby formed through which undesired fluids can be led away or through which cleaning fluids can be introduced.

(12) INTERNATIONAL APPLICATION PUBLISHED UNDER THE PATENT COOPERATION TREATY (PCT)

(19) World Intellectual Property Organization
International Bureau(43) International Publication Date
1 November 2001 (01.11.2001)

PCT

(10) International Publication Number
WO 01/81809 A1

- (51) International Patent Classification⁷: F16L 11/16
- (21) International Application Number: PCT/DK01/00262
- (22) International Filing Date: 11 April 2001 (11.04.2001)
- (25) Filing Language: Danish
- (26) Publication Language: English
- (30) Priority Data:
PA 2000 00672 25 April 2000 (25.04.2000) DK
PA 2000 01707 15 November 2000 (15.11.2000) DK
- (71) Applicant (for all designated States except US): NKT FLEXIBLES I/S [DK/DK]; Priorparken 510, DK-2605 Brøndby (DK).
- (72) Inventors; and
(75) Inventors/Applicants (for US only): GLEJBØL, Kristian [DK/DK]; Kvædehaven 109, DK-2600 Glostrup (DK). WEDEL-HEINEN, Jakob [DK/DK]; Mosehøjvej 46B, DK-2920 Charlottenlund (DK). RYTTER, Jan, Christian [DK/DK]; Kastрупvej 18, 4. tv., DK-2300 København S (DK).
- (74) Agent: LARSEN & BIRKEHOLM A/S; Skandinavisk Patentbureau, Banegårdspladsen 1, P.O. Box 362, DK-1570 København V (DK).
- (81) Designated States (national): AE, AG, AL, AM, AT, AT (utility model), AU, AZ, BA, BB, BG, BR, BY, BZ, CA, CH, CN, CO, CR, CU, CZ, CZ (utility model), DE, DE (utility model), DK, DK (utility model), DM, DZ, EE, EE (utility model), ES, FI, FI (utility model), GB, GD, GE, GH, GM, HR, HU, ID, IL, IN, IS, JP, KE, KG, KP, KR, KZ, LC, LK, LR, LS, LT, LU, LV, MA, MD, MG, MK, MN, MW, MX, MZ, NO, NZ, PL, PT, RO, RU, SD, SE, SG, SI, SK, SK (utility model), SL, TJ, TM, TR, TT, TZ, UA, UG, US, UZ, VN, YU, ZA, ZW.
- (84) Designated States (regional): ARIPO patent (GH, GM, KE, LS, MW, MZ, SD, SL, SZ, TZ, UG, ZW), Eurasian patent (AM, AZ, BY, KG, KZ, MD, RU, TJ, TM), European patent (AT, BE, CH, CY, DE, DK, ES, FI, FR, GB, GR, IE, IT, LU, MC, NL, PT, SE, TR), OAPI patent (BF, BJ, CF, CG, CI, CM, GA, GN, GW, ML, MR, NE, SN, TD, TG).
- Published:
— with international search report
- For two-letter codes and other abbreviations, refer to the "Guidance Notes on Codes and Abbreviations" appearing at the beginning of each regular issue of the PCT Gazette.

(54) Title: ARMoured, FLEXIBLE PIPE AND USE OF SAME

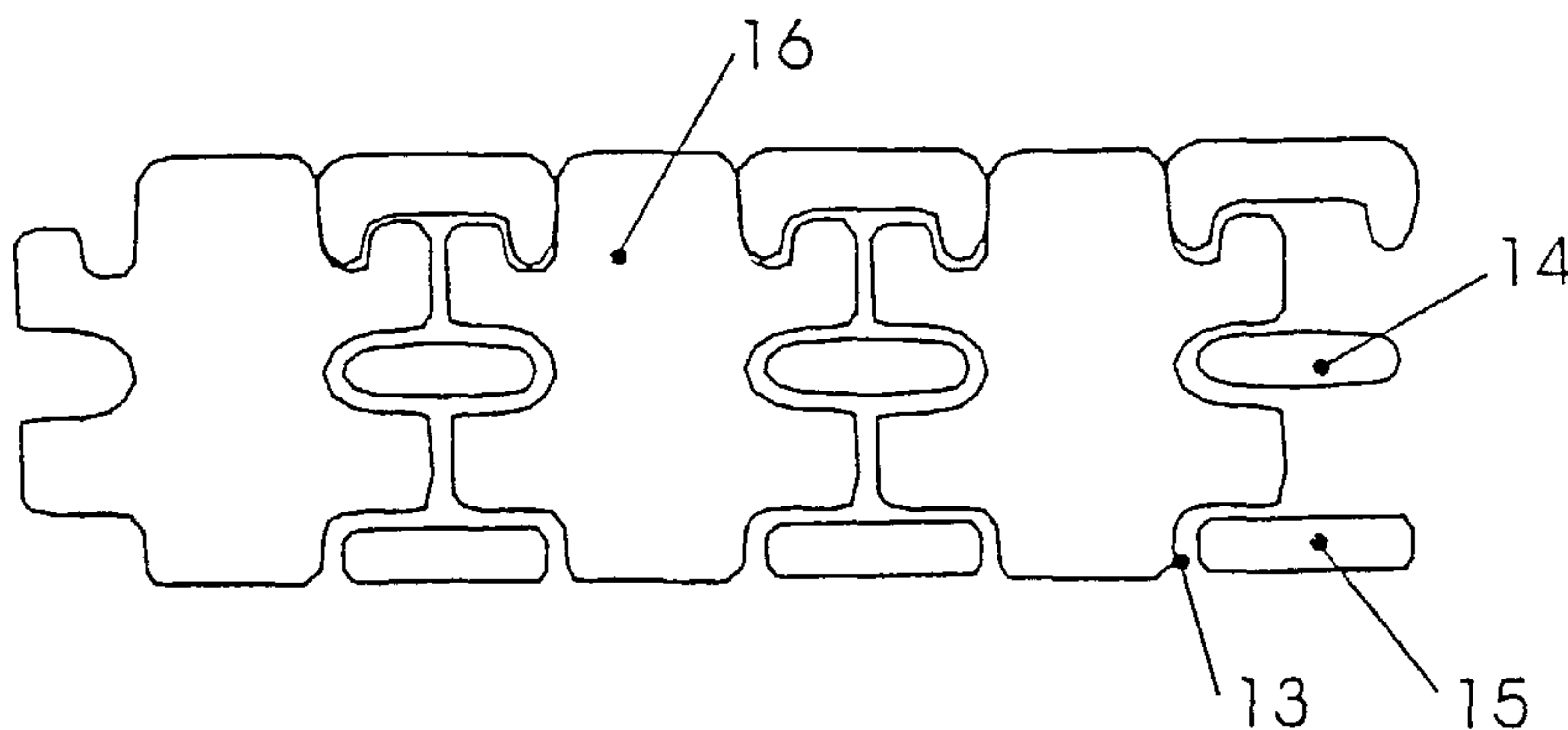

(57) Abstract: A flexible armored pipe, which comprises an inner liner, which is surrounded by a pressure armour, is built up by the joining together of profiles, which have a number of recesses. According to the invention, the profiles are configured as K-profiles (10, 16, 17), which have recesses (10a, 10b, 10c, 10d), which are arranged in adjoining surfaces of the profile. When the profiles are brought together, the recesses form a cavity in which a locking element (12, 14, 18) can be

inserted, the function of which is to prevent displacement of the K-profiles at right-angles to the axial direction of the pipe when this is exposed to axial, compressive forces. The locking element can be I-shaped (14), be circular or be configured as a wire (18) with a C-shaped cross-section. The locking element can also be made either of a rigid or an elastic, deformable material. With a C-shaped locking element, the whole of the cavity, which is formed by the recesses, is not filled out. A channel is hereby formed through which undesired fluids can be led away or through which cleaning fluids can be introduced.

WO 01/81809 A1

Armoured, flexible pipe and use of same

The invention concerns a flexible, armoured pipe comprising an inner liner, which among other things is surrounded by a spirally-wound pressure
5 armour, where this is built up of a number of profiles in which a number of recesses are provided, and where the profiles are held together by a number of locking profiles.

The invention also concerns a use of the pipe.

10

Pipes of the above-mentioned type normally comprise an inner barrier layer, the so-called inner liner, which forms a barrier against the out-flow of the fluid which is desired to be transported through the pipe. Moreover, pipes of the above-mentioned type comprise an outer barrier layer, the so-called outer liner, which prevents the surrounding environment from
15 influencing the space in between the inner and the outer liner.

On the outside of the inner liner one or more armouring layers are wound, which are not chemically bound to the remaining components of the pipe, but can move in relation to these, which ensures the flexibility of the pipe
20 during laying-out and operation.

The whole of the pipe armouring is most often placed between the inner and the outer liner, but in certain cases only a part of the armouring layers will be placed between the inner and the outer liner, while the remaining
25 part of the armouring is placed outside the outer liner. When a part of the armouring lies outside the outer liner, an additional layer can be applied to the outside of the pipe with the object of protecting the outermost armouring layer against mechanical damage.

30

In order to prevent the collapse of the inner liner, the inner side of this is often lined with a flexible, wound, permeable pipe, a so-called carcass.

5 The above-mentioned type of flexible pipe is used, among other things, for the transport of fluids and gases in different depths of water. They are used especially in situations where very high or varying water pressure exists along the longitudinal axis of the pipe. As an example can be mentioned riser pipes which extend from the seabed up to an installation on or near the surface of the sea. Pipes of this type are also used between
10 installations, which are located at great depths on the seabed, or between installations near the surface of the sea.

Some of the armouring layers are wound with a great angle relative to the longitudinal direction of the pipe, and will therefore primarily be able to
15 absorb the radial forces that arise as a result of outer or inner pressure. The profiles thus prevent the collapse or rupture of the pipe as a result of pressure influences and are therefore called pressure armour.

The pressure armour will always lie in the space between the pipe's inner
20 and outer liner, and is most often built up of different profiles in metal.

In that very high inner pressure can exist inside the pipe, a mutual anchoring of the pressure-bearing profiles is of great importance, since a slipping of these along the axis of the pipe can result in too great a mutual
25 profile distance with damage of the inner liner as a consequence. The mutual mechanical anchoring is achieved by configuring the profiles in such a manner that they lock together mechanically when they are wound.

In order to ensure the flexibility of the pipe, the pressure armour layer is
30 designed so that a limited mutual movement of the pressure-bearing profiles is permitted.

Unlike the pressure armour, profiles, which are wound with a small angle in relation to the longitudinal axis of the pipe, will not be able to absorb radial forces to any significant degree, but on the other hand are able to absorb forces exerted along the longitudinal axis of the pipe. In the following, this type of armouring will be referred to as tension armour, in that its primary task is to absorb tensile forces as a result of inner pressure in the pipe and its suspension. The tension armour is placed either in the space between the inner and the outer liner, or on the outside of the outer liner.

Under certain conditions of operation, the pipe will be exposed to compressive, axial forces, which will compress the pipe. Providing that the tension armour is prevented from expanding radially, it will be able to absorb these compressive forces. However, if the pipe is constructed in such a manner that the radial expansion of the pipe's tension armour is not prevented, the tension armour will not be able to absorb the compressive, axial forces, in that these will be absorbed primarily by the inner and the outer liner. This compression can continue until the free volume between the pressure armour profiles is used up, after which the compressive, axial forces will be absorbed primarily by the pressure armour, which is made of a material with far greater rigidity than the inner and outer liner. In this connection it is a problem that the pressure armour is not stable in compression, the reason being that the pressure armour profiles will have a tendency to slide out over each other with subsequent damage to the pipe.

It is an object of the present invention to provide a new configuration of pressure armour profiles that prevents the profiles from sliding out over each other.

It is also an object of the invention to increase the barrier characteristics of the pressure armour, which in certain cases can considerably increase the functionality of the finished pipe.

The objects of the invention are achieved in that at least two of the recesses are provided along adjoining surfaces of the profiles in the spiral winding, and that a locking element is arranged in a cavity which is formed by the two adjoining recesses, or that the profile is configured with at least
5 one recess and at least one adjoining tongue.

Means are thus provided in the armouring for the prevention of uncontrolled, radial displacement of the primary, spirally-wound profiles. Moreover, means are provided in the armouring, which prevent a free, or
10 almost free flow between the concave and the convex side of the armouring. Furthermore, the primary, spirally-wound profiles are provided with at least two recesses in which a profile of another kind is placed, whereby a locking of the primary, spirally-wound profiles against mutual, uncontrolled, axial displacement is achieved.

15 In a most preferred embodiment, as disclosed in more detail in claim 2, the profile is configured as a K-profile with four recesses. A locking against uncontrolled, radial displacement is hereby achieved, in that at least two recesses are provided along adjoining surfaces in K-profiles, and in that a
20 locking element is arranged in the space which is formed by the two adjoining recesses.

In other words, the configuration of the armouring according to the invention distinguishes itself from hitherto-known pressure armouring by a mutual
25 locking of the K-profiles, not only along the axial direction of the pipe, but also at right-angles hereto, which can be attributed to the use of locking profiles and locking elements with different functions.

As disclosed in claim 3, by the K-profile having two recesses disposed in
30 the corners of the profile, and by an I-profile being placed in the space formed by two recesses in adjoining profiles, it is ensured that in the event

of great pressure influences, there is no migration of material, e.g. inner liner material, into the spaces which exist between the profiles.

5 As disclosed in claim 8, by the locking element being made of an elastic, deformable material, an essential barrier against migration of fluids between the concave and convex parts of the armouring is achieved, which can give the armouring an important extra functionality when the locking profile is configured so that the deformation of this is necessary for it to be accommodated in the adjoining recesses.

10

As disclosed in claim 9, by configuring the locking element as a wire with a C-shaped cross-section, it is ensured that a longitudinal channel is provided which, for example, can be used for the leading away of undesired fluids or the supply of cleaning liquids or the like.

15

Expedient embodiments of the invention are also disclosed in the dependent claims.

20

As mentioned, the invention also concerns a use of the pipe. This use is disclosed in more detail in claim 14.

The invention will now be explained in more detail with reference to the drawing, in which

25 fig. 1 shows a normal construction of a flexible, armoured pipe with its different layers,

fig. 2 shows an alternative construction of a flexible, armoured pipe, where the tension armour is placed on the outside of the inner
30 liner,

- fig. 3 shows a K-profile for the pressure armour according to the invention,
- fig. 4 shows K-profiles according to fig. 3 joined together in the formation of armour,
- fig. 5 shows a second embodiment of joined-together K-profiles according to the invention,
- figs. 6 & 7 show further embodiments corresponding to fig. 3, but with other locking elements, while
- fig. 8 shows a further embodiment of the profile according to the invention, where a tongue replaces the one of the adjoining recesses and the locking profile.

In fig. 1 a pipe is seen which consists of an inner liner 3, which surrounds a carcass 1 consisting of a spirally-wound metal band 2, which forms an inner pipe. During its production, the metal band 2 is formed with flaps that engage with one another, so that they hereby lock the individual windings in the metal band 2 to one another in such a manner that the carcass 1 is flexible. Since the inner carcass 1 in itself is not impermeable, the object of the surrounding inner liner 3 is to prevent the flow of fluids to or from the inside of the pipe.

25

On the outside of the inner liner 3, one or more layers of profiles 5,6 are wound in a spiral manner, which form windings with a large angle in relation to the longitudinal direction of the pipe. As a consequence of the large angle, these profiles will primarily be able to absorb radial forces that arise due to inner or outer pressure. The inner pressure arises during operation of the pipe. The outer pressure stems partly from the hydrostatic pressure

30

of the surroundings, and partly from mechanical influences during the laying-out of the pipe. The windings thus form a pressure armour which prevents rupture of the inner liner 3 as a result of a high pressure on the inside of the pipe, or its collapse as a result of a high pressure on the outside of the pipe.

Fig. 1 also shows that a tension armour, which consists of one or more spirally-wound layers 7,8, is provided on the outside of the pressure armour.

Between the pressure armour and the tension armour an intermediate sheath can be laid, the object of which is to prevent fluids from migrating between the tension armour and the pressure armour. An outer sheath 9 finally surrounds these layers.

Since the present invention does not concern the intermediate sheath, the tension armour and the outer sheath, these elements will not be discussed in more detail.

In comparison with the embodiment in fig. 1, fig. 2 shows an alternative positioning of the pipe's outer liner.

An embodiment such as shown in fig. 2 will prevent the build-up of compressive stresses in the tension armour, which makes this embodiment particularly advantageous when the tension armour elements are made of a fibre-reinforced plastic composite.

According to the invention, in a first embodiment as shown in fig. 3, the pressure armour is built up of K-profiles 10 which, in a first embodiment, have four locking grooves or recesses 10a, 10b, 10c and 10d. As shown in fig. 4, these K-profiles are held together by locking profiles in the form of C-

profiles 11, which can engage in the recesses 10b, 10c, which lie on the outer side of the pressure armour.

As will also be seen in fig. 4, in the recesses 10a and 10d, which form a cavity along adjoining edges of the K-profile, a locking element 12 is placed. This locking element 12 absorbs radial forces, which could otherwise displace the K-profiles along the adjoining edges and cause the K-profiles to "tip".

In fig. 5 is seen a variant of the K-profile shown with the reference number 16. This corresponds to the profile in fig. 3, but with the difference that two of the corners of the K-profile 16 are configured with cut-outs to accommodate an I-profile 15, the function of which is to prevent material, such as liner material, from running from the inside of the pipe out towards the locking elements and the C-profiles, in that a compressive force on the I-profile 15 from the inside of the pipe will block the passage of material.

Fig. 6 shows an embodiment corresponding to that in fig. 4. The difference is that the recesses are semicircular in shape, and that the locking element has a circular cross-section.

Fig. 7 shows an embodiment like that in fig. 3, but now with a locking element 18 with a C-shaped cross-section placed in the cavity. This locking element involves that not the entire cavity is filled out, but that a channel 19 is provided in the cavity. This channel can possibly be used for the removal of undesired fluids or for the introduction of cleaning fluids into the pipe. The removal can, for example, be controlled by establishing a suitable difference in pressure between the ends of the pipe.

Finally, fig. 8 shows a variant 17 of the K-profile, which, along its adjoining edges (when two or more K-profiles engage with one another), is provided

with a recess and a tongue corresponding hereto. In this way, it becomes possible to avoid the use of locking elements, which can have certain advantages from the point of view of production technique.

5 For all of the embodiments described, it applies that the material in that profile which prevents slipping will not be loaded as heavily as the surrounding K-profiles. In the configuration of this profile, there is thus great freedom of choice of materials other than the material of which the K-profiles are made, should this be expedient.

10

As examples of the use of alternative metals, mention can be made of a round wire, cf. fig. 6, where this wire can be made of a metal or an alloy with a lower semi-conductor potential than that metal of which the surrounding K-profiles are made. Such a method will ensure cathodic protection of the K-profiles.

15

Another example can be in an embodiment as shown in fig. 7, merely with a zinc strip rolled down in the C-profile 18, which is surrounded by K-profiles 10. Since this zinc strip will be in galvanic contact with the surrounding armour, it will effect a very effective protection of the system against corrosion.

20

It is obvious that the present invention can be exercised in other ways than those shown above while still within the scope of the patent claims.

25

For example, the K-profiles can with advantage also be used as internal pressure armour in the inner liner, in cases where this is desired to be armoured against very great external compressive forces.

Furthermore, there is great freedom in the use of the principles of the invention in cases where several pipes are connected by means of coupling elements etc.

CLAIMS

1. Flexible, armoured pipe which comprises an inner liner which, among other things, is surrounded by a spirally-wound pressure armour, where
5 this is built up of a number of profiles (10,16,17) in which a number of recesses (10a,10b,10c,10d) are provided, and where the profiles are held together by a number of locking profiles, **characterized in** that at least two of the recesses are provided along adjoining surfaces in the profiles of the spiral winding, and that a locking element (12,14,18) is
10 arranged in a cavity which is formed by the two adjoining recesses, or that the profile is provided with at least one recess and at least one adjoining tongue.
2. Flexible, armoured pipe according to claim 1, **characterized in** that the
15 profile is configured as a K-profile with four recesses.
3. Flexible, armoured pipe according to claim 1, **characterized in** that the K-profile has two recesses (13) which are arranged in the corners of the profile, and that an I-profile (15) is provided in the cavity which is formed
20 by the two recesses in adjoining profiles.
4. Flexible, armoured pipe according to claim 1 – 3, **characterized in** that the locking element wholly or partly fills out the cavity.
- 25 5. Flexible, armoured pipe according to claim 1 – 4, **characterized in** that the locking element (14) is configured as an I-profile.
6. Flexible, armoured pipe according to claim 1 – 3, **characterized in** that the cavity is formed geometrically as two semicircles.

7. Flexible, armoured pipe according to claim 6, **characterized in** that the locking element is configured with a substantially circular cross-section.
8. Flexible, armoured pipe according to one or more of the foregoing claims, **characterized in** that the locking element is made of an elastic, deformable material.
9. Flexible, armoured pipe according to claim 1 – 4, **characterized in** that the locking element is configured as a wire with a C-shaped cross-section.
10. Flexible, armoured pipe according to claim 1 – 9, **characterized in** that the locking profiles are C-shaped.
11. Flexible, armoured pipe according to claim 1 – 10, **characterized in** that the profiles consist of a material which wholly or partly is made of metal, a metal alloy or a ceramic-reinforced metal material.
12. Flexible, armoured pipe according to claim 1 – 11, **characterized in** that the profiles consist of a material which wholly or partly is made of a polymer or an armoured polymer.
13. Flexible, armoured pipe according to claim 1 – 12, **characterized in** that the inner liner surrounds a carcass, and that the carcass is configured as the pressure armour according to claims 1, 2 or 4 – 9.
14. Use of a flexible, armoured pipe according to any of the claims 1 – 13 for the transport of fluids such as water, ammonia, hydrocarbons etc.

1/4

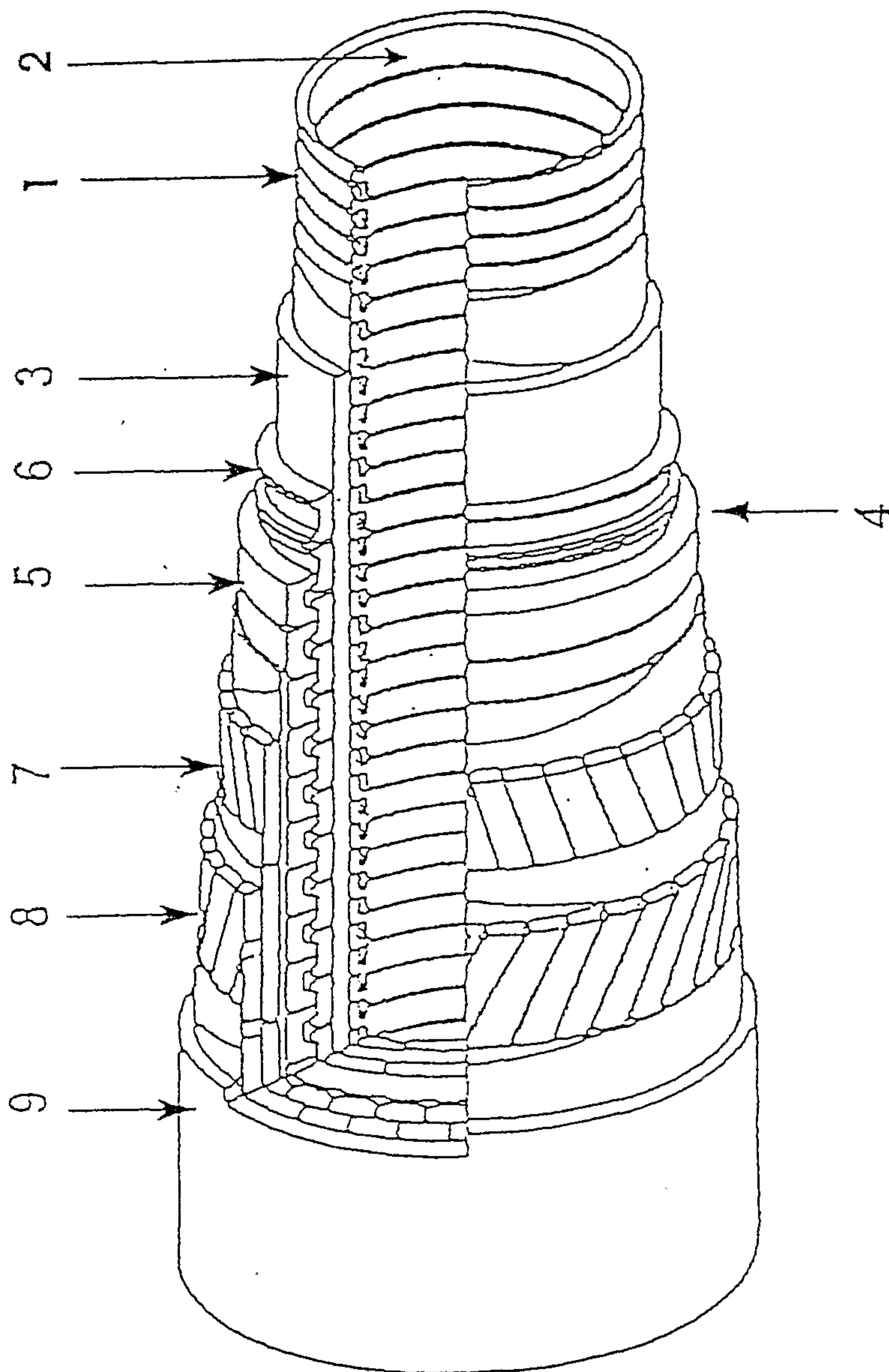

Fig 1

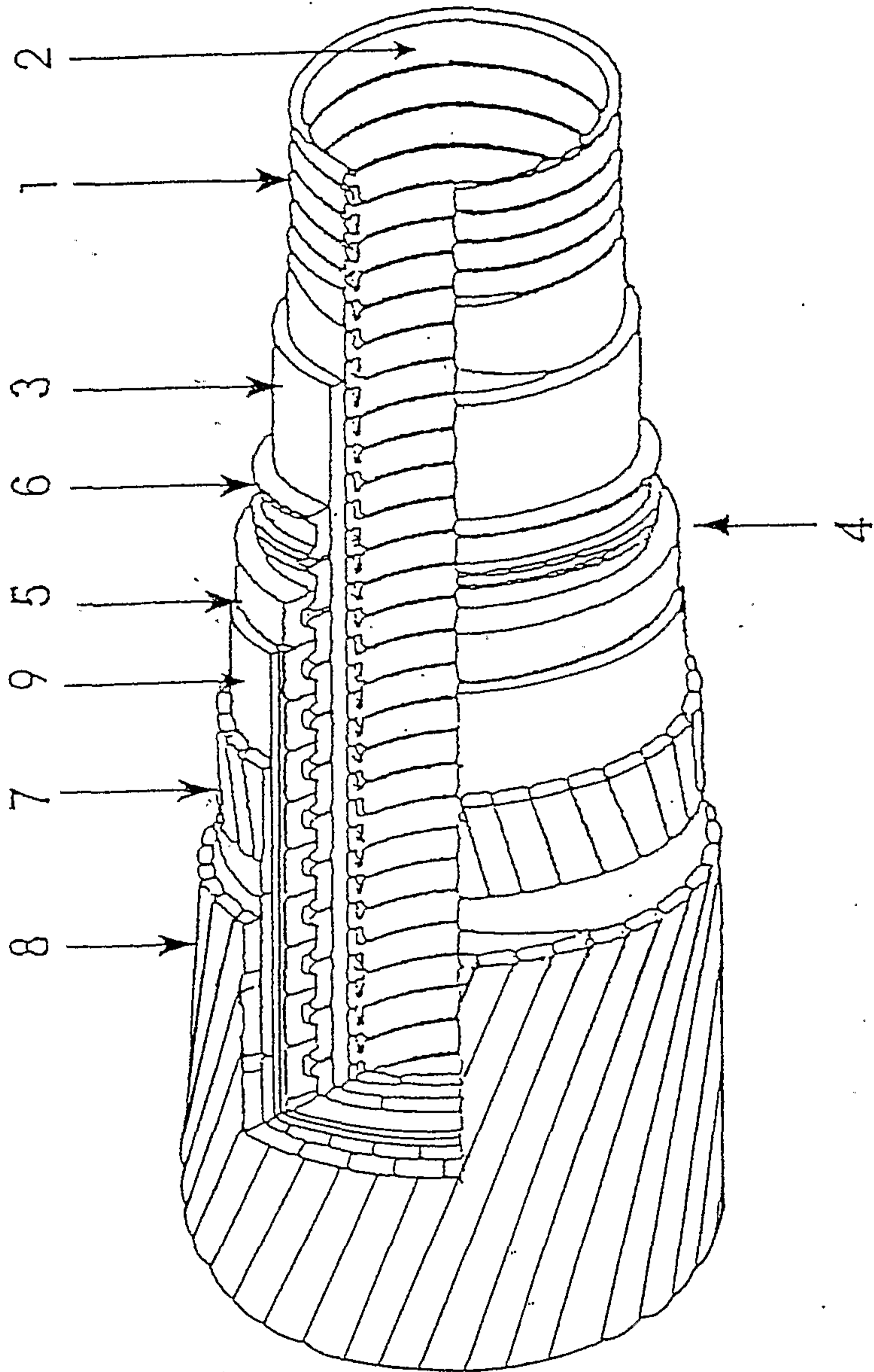

Fig 2

3/4

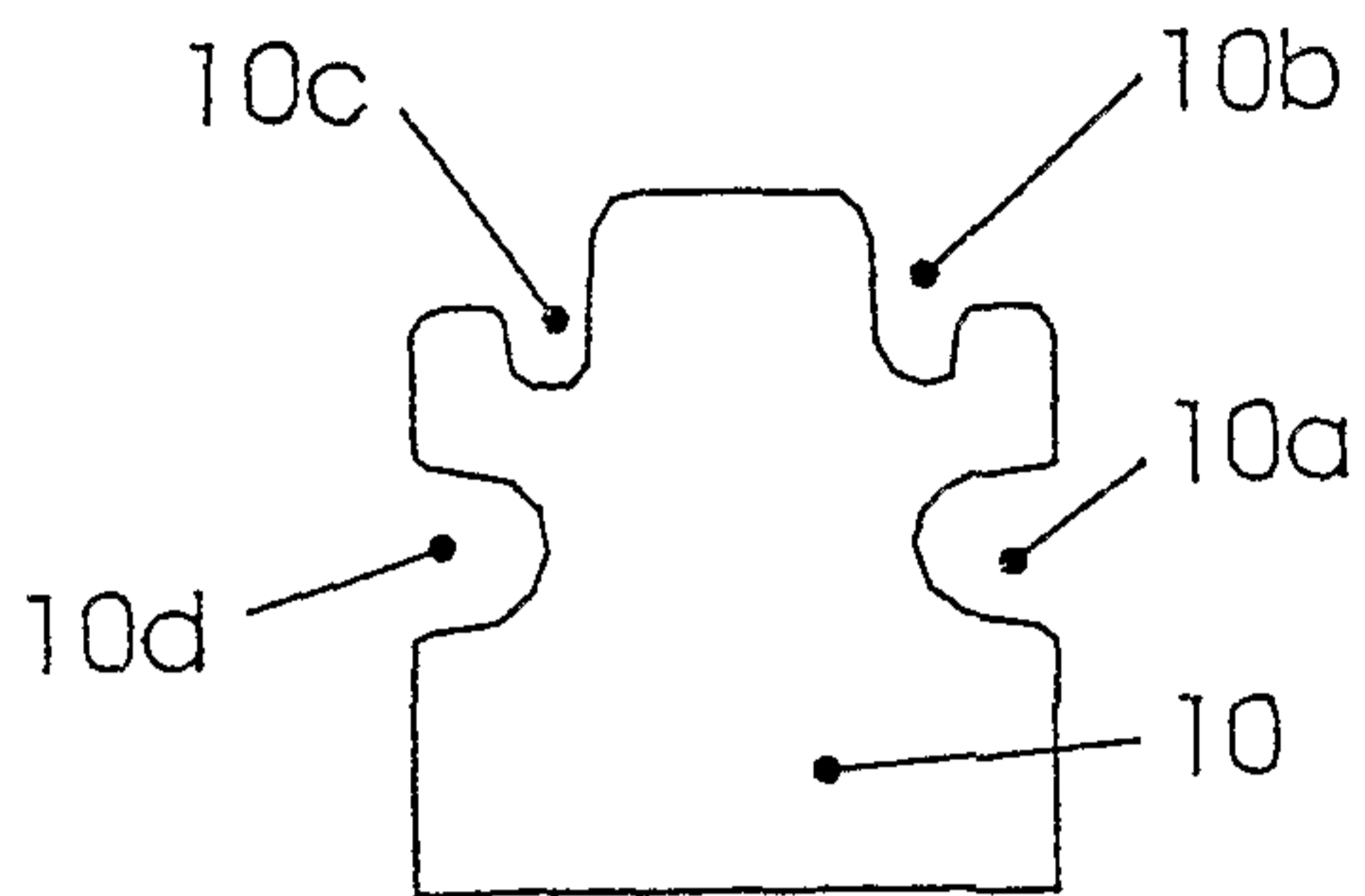

Fig 3

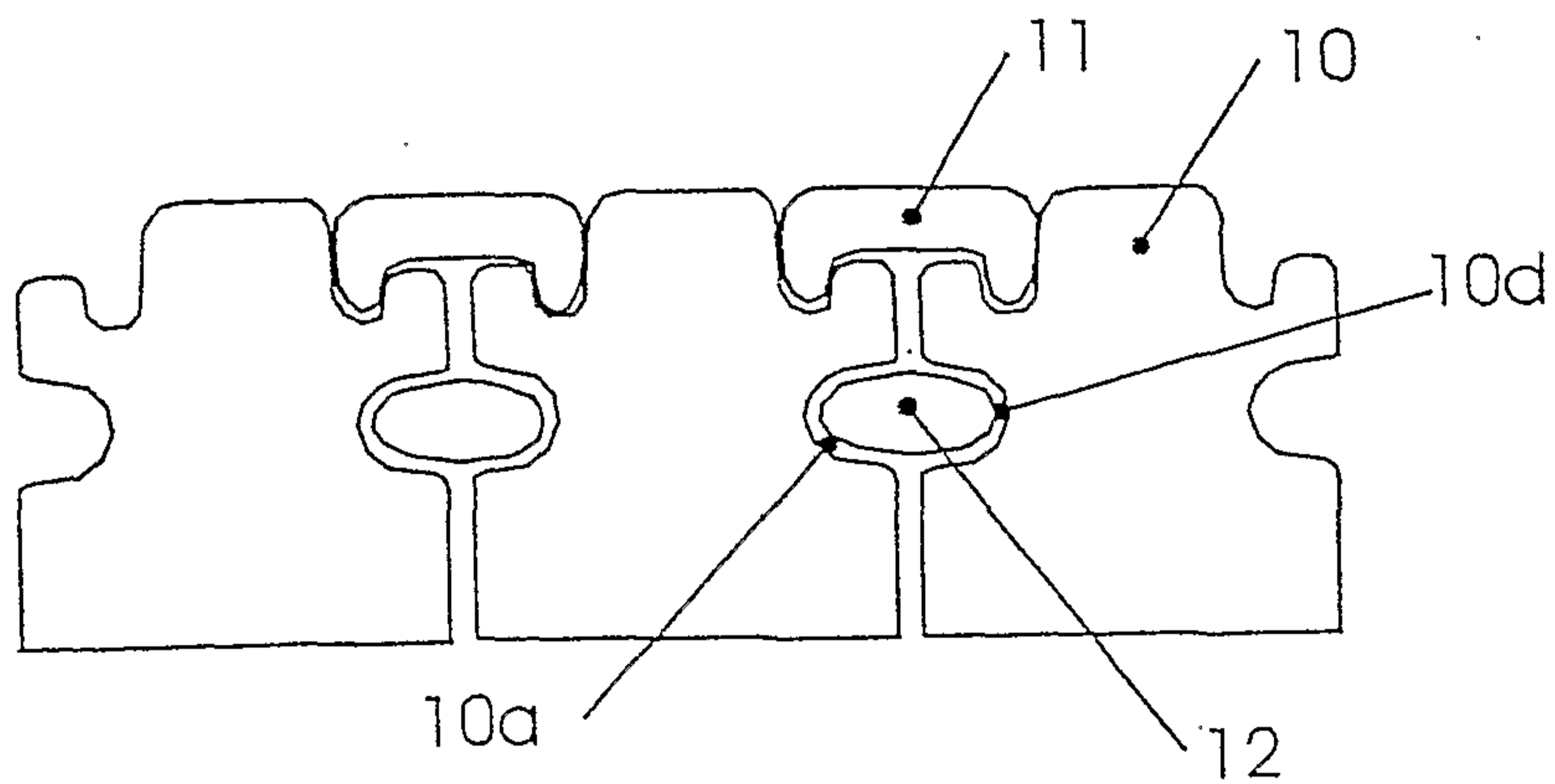

Fig 4

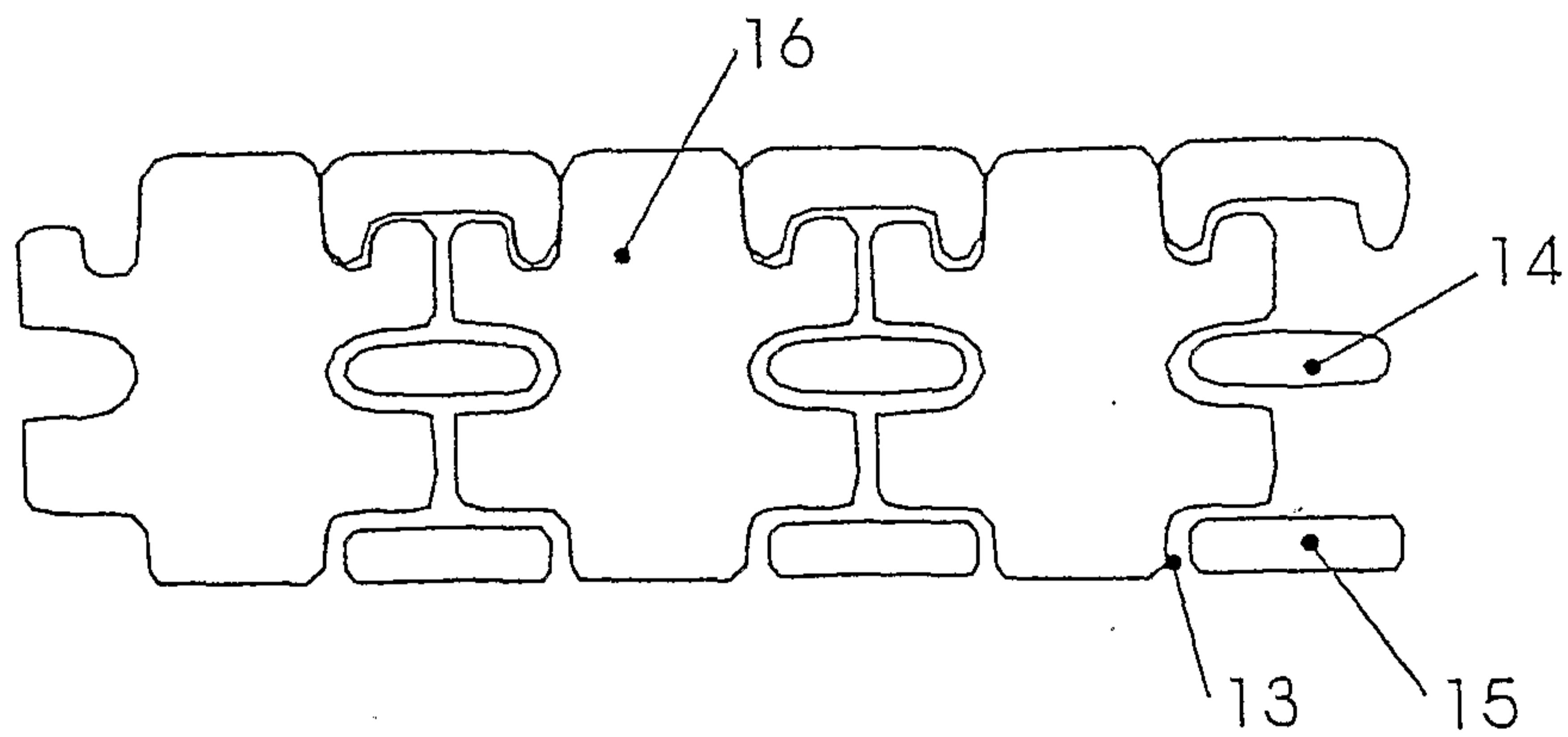

Fig 5

4/4

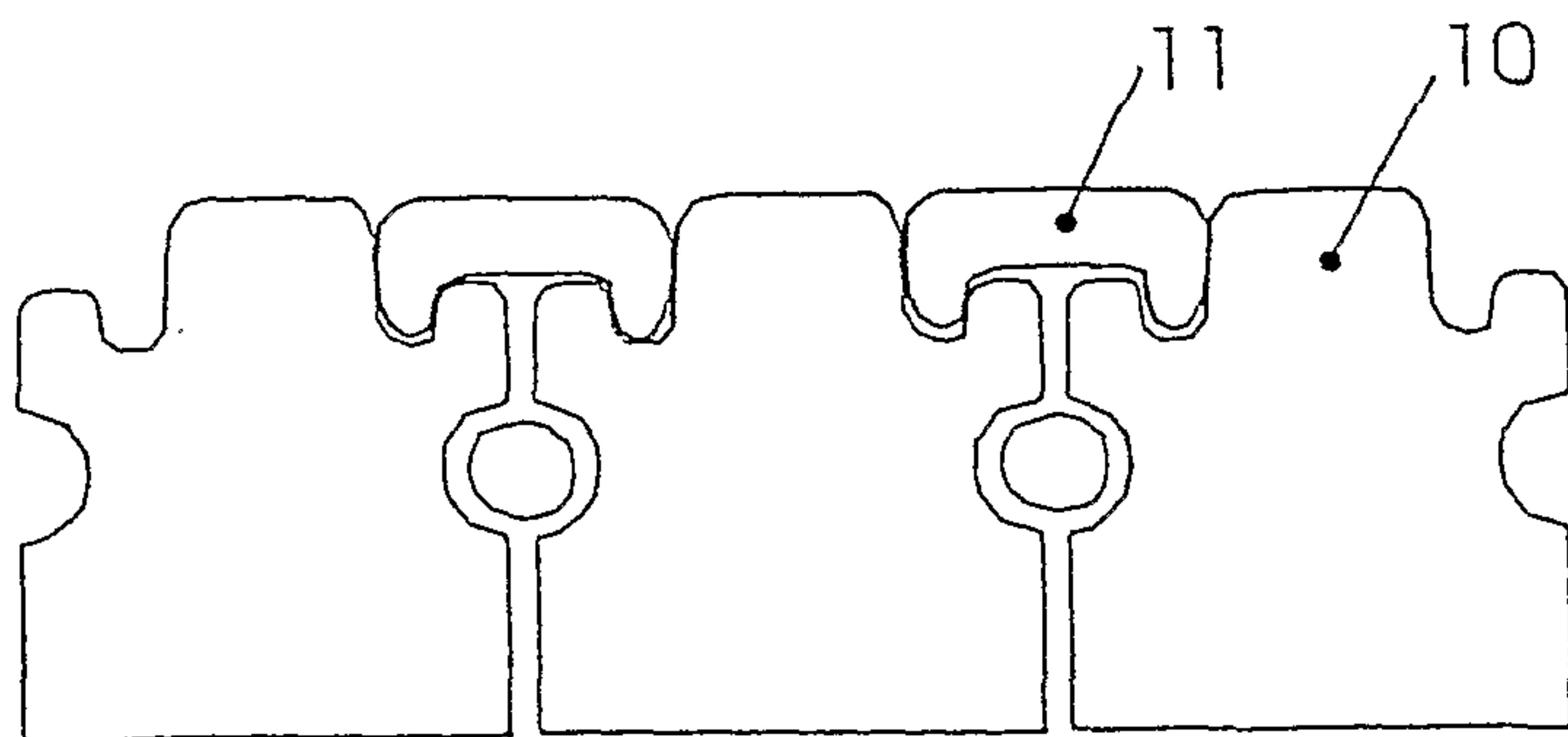

Fig 6

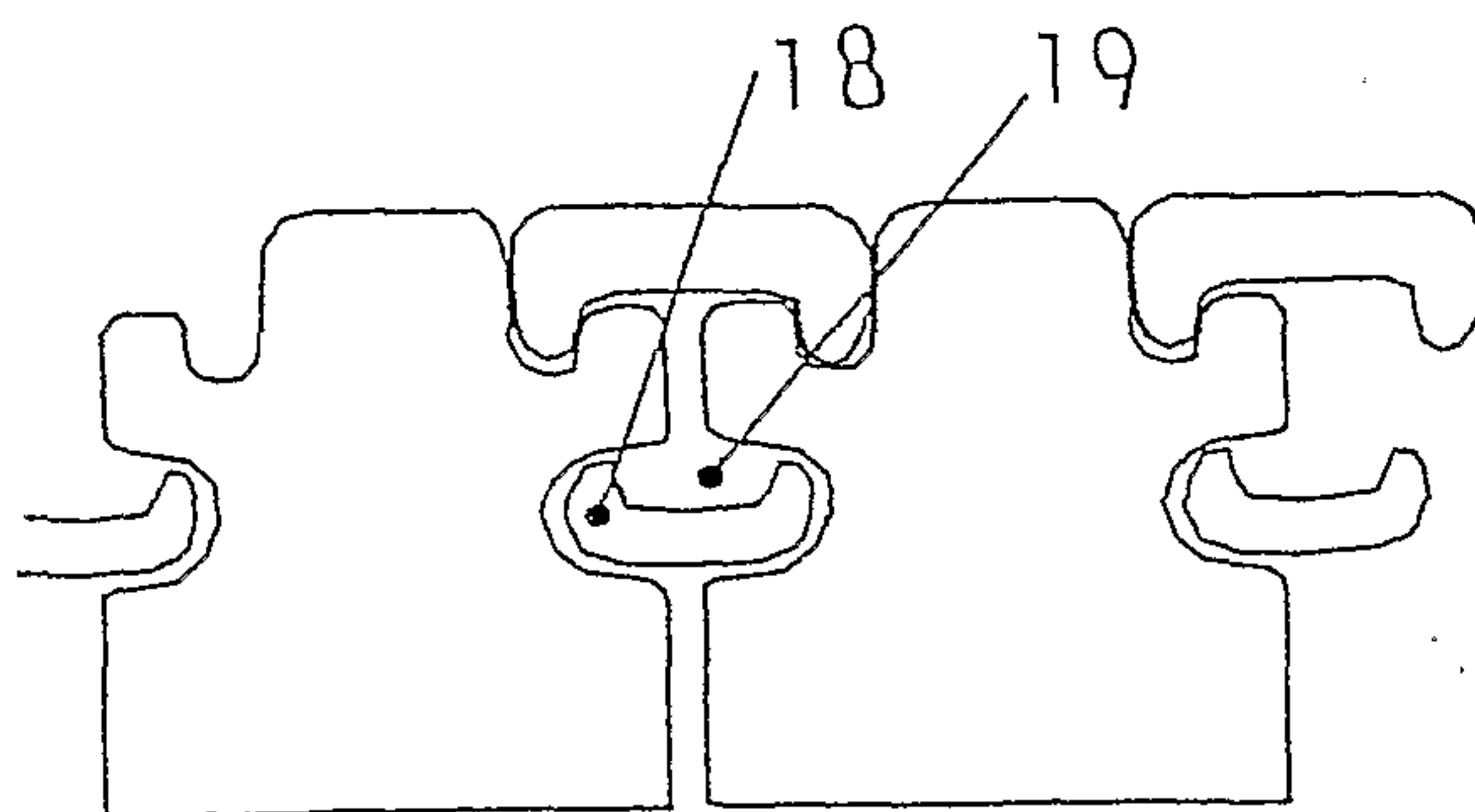

Fig7

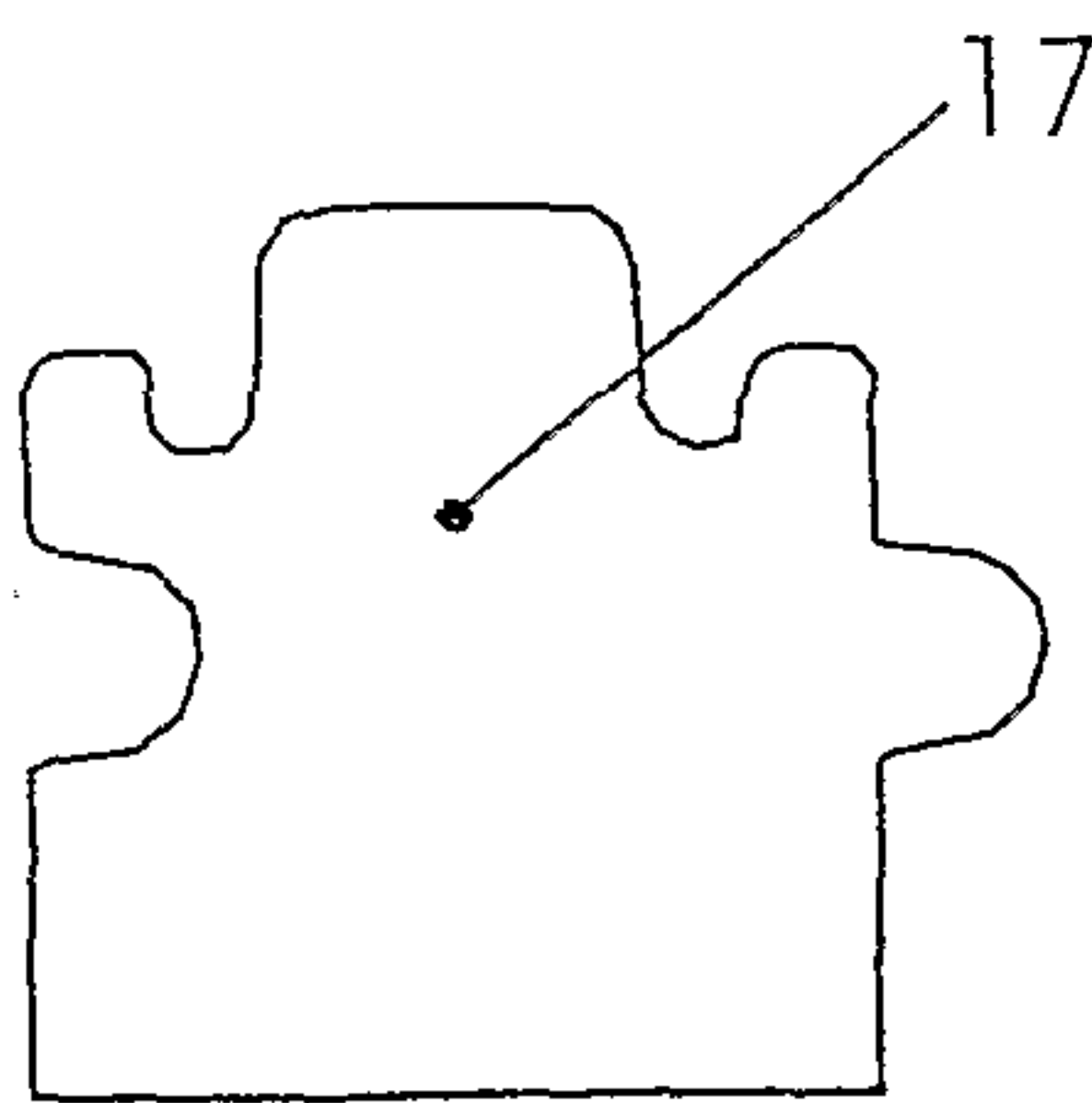

Fig8

