

[54] **ELECTROSTATIC FOCUSSED DEVICES
ESPECIALLY FOR MICROWAVE TUBES**

[75] Inventors: **Alain Bert; Roger Enjalbert; Pierre Kern**, all of Paris, France

[73] Assignee: **Thomson-CSF, Paris, France**

[22] Filed: **Apr. 5, 1972**

[21] Appl. No.: **241,163**

[30] **Foreign Application Priority Data**

Apr. 27, 1971 France 71.14989

[52] U.S. Cl. 315/5.34, 313/256, 313/287,
313/252

[51] Int. Cl. H01j 23/08

[58] Field of Search .. 315/5.34, 5.35; 313/256, 261,
313/287, 253, 252

[56] **References Cited**

UNITED STATES PATENTS

2,825,835 3/1958 Heppner 313/153 X

3,449,617	6/1969	Kreuchen et al.	315/5.34
3,409,794	11/1968	Heathcote.....	313/261
3,483,419	12/1969	Luebke.....	315/5.34
2,972,079	2/1961	Wolkstein.....	313/256 X
3,436,588	4/1969	Hechtel.....	315/5.34 X
3,681,643	8/1972	Blatter.....	313/261
3,295,000	12/1966	Johnson.....	313/256

Primary Examiner—Rudolph V. Rolinec
Assistant Examiner—Saxfield Chatmon, Jr.
Attorney, Agent, or Firm—John W. Malley et al.

[57] **ABSTRACT**

The focussing devices of the invention comprise a metal electrode (6) assembled in the envelope (10) through which the electron beam being focussed propagates, said assembly being realised by means of a fixing system comprising a flexible skirt (11) attached around the envelope, and rigid insulating components rigidly attached on the one hand to the electrode (6) and on the other to the skirt (11).

9 Claims, 7 Drawing Figures

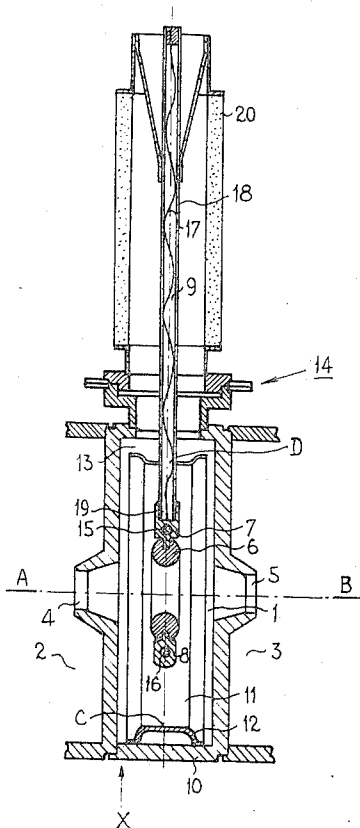

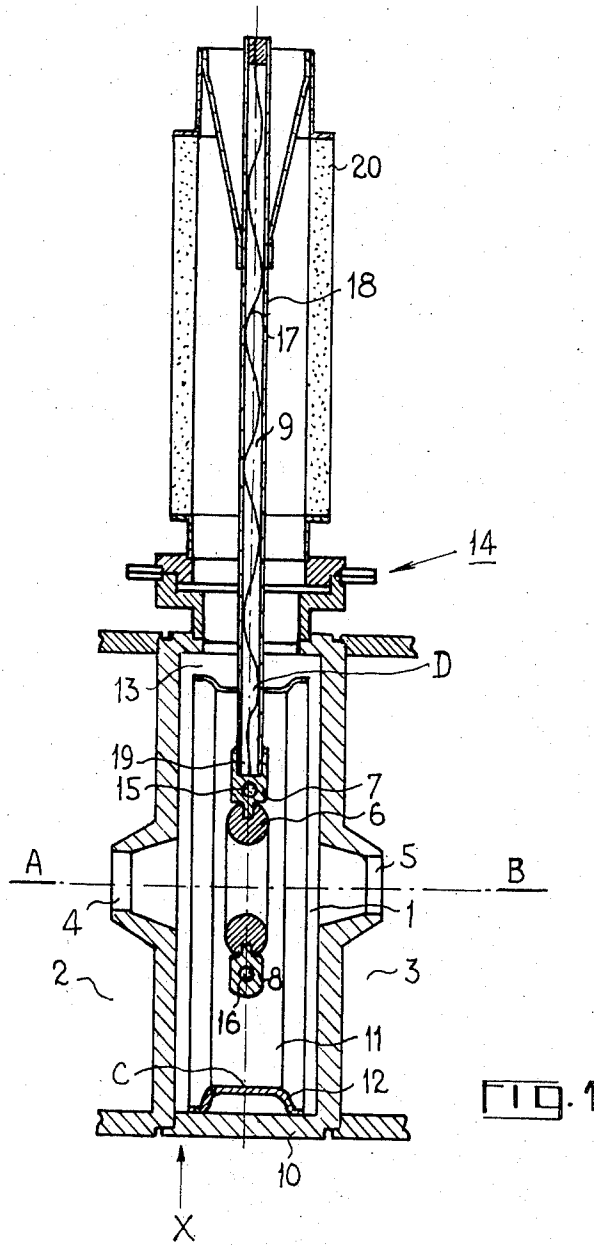

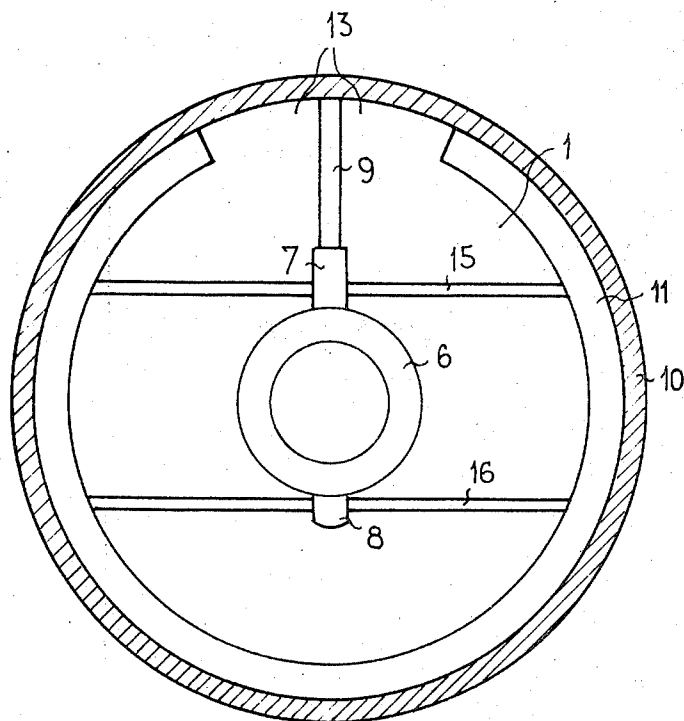

FIG. 2

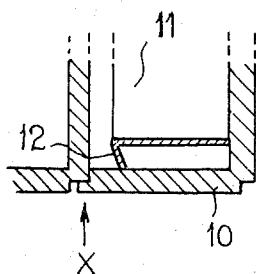

FIG. 3

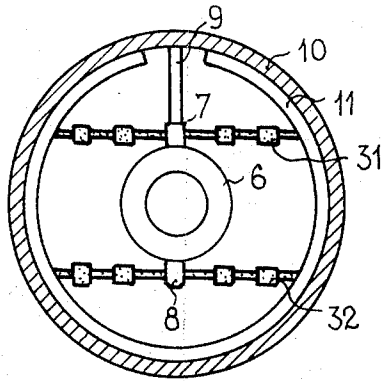

FIG. 4

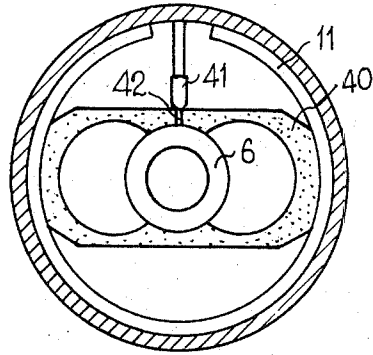

FIG. 5

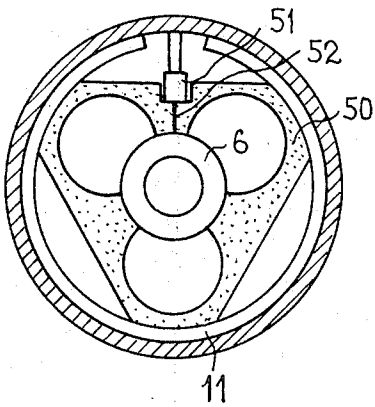

FIG. 6

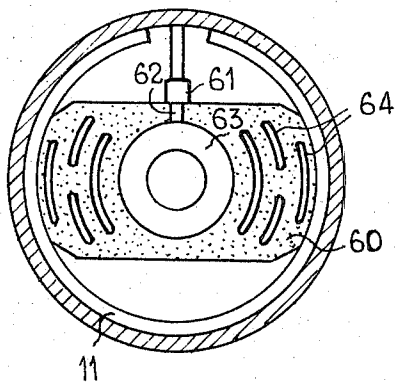

FIG. 7

ELECTROSTATIC FOCUSING DEVICES ESPECIALLY FOR MICROWAVE TUBES

The present invention relates to improvements in electrostatic electron beam focussing devices, or electrostatic lenses. It relates more particularly to electrostatic lenses for microwave tubes and to the means by which they are attached in such tubes.

The problems of focussing electron beams are very important in microwave tubes and more particularly in tubes where the beam passes over a long trajectory and where important defocussing may arise. This is the case, for example, in multicavity klystron amplifiers where efficient focussing is essential in the drift spaces between the different cavities.

Magnetic focussing devices are frequently used, because their use requires less accuracy than do electrostatic focussing devices. In electrostatic devices the positioning of the focussing device must be extremely accurate and the electrical insulation gives rise to extremely delicate technological problems. The major drawback of magnetic focussing devices is their weight, which is very much higher than that of electrostatic focussing devices and becomes prohibitive if the tubes to which they are fitted are part for example of airborne equipment.

Electrostatic focussing devices for microwave tubes generally comprise an annular conductive electrode, of a toroidal shape for example, raised to a negative potential in relation to the reference potential which is that of the tube body for example, thus constituting together with said body an electrostatic lens centred on the axis of the beam and being attached to the tube enclosure by a fixing system which both maintains the electrode in the proper position and electrically insulates it from the other tube components.

The design of this fixing or attachment system is a particularly delicate matter. In other words, the position of the electrode must be highly accurate at the time of manufacture of the tube, must remain so during the various stages of its manufacture, in particular the stoving operation, and must also remain so during use. Thus, a system which is accurate from the beginning of its construction is required; the deformations appearing in this system during the stoving operation must not modify the centering of the electrode; furthermore said system must be extremely stable during operation of the tube, and particularly if the tube is inserted in an airborne equipment which is subjected to severe vibrations.

The known fixing or attachment devices make use of several artifices in order to try to resolve these various problems. For example, the system for fixing the electrode to the tube comprises alumina rods which are inserted into the electrode without being soldered or brazed thereto and which are assembled onto the tube enclosure or envelope by means of elements having one degree of freedom, in order to avoid the appearance of eccentricity during the stoving operation due to the expansion of the electrode and of the alumina rods in particular; such a non-rigid fixing system makes it difficult to obtain a convenient centering and possibly involves twisting phenomena, the electrode axis then making an angle with the axis of the electron beam. Moreover, it has major drawbacks as far as achieving good vibration resistance is concerned.

The object of the invention is to provide an electrostatic focussing device in which the system for attaching the electrode to the envelope provides both good electrical insulation and accurate and stable positioning of the electrode in relation to the electron beam axis, this both during manufacturing and during operation of the tube, even in situations where the device is subjected to severe vibrations.

In accordance with the invention, an electrostatic device for focussing an electron beam propagating within an envelope along an axis which is fixed in relation to said envelope, and comprising an annular electrode having applied a potential which is negative in relation to said envelope by means of a voltage supply lead penetrating within said envelope, and a system for fixing said electrode to said envelope while assuming that they are electrically insulated from one another, and that said electrode is centered onto the axis of the electron beam, said system comprising a flexible skirt attached to the interior of said envelope around the axis of the electron beam, and components made of rigid insulating material which maintain said electrode rigidly fixed to said skirt, said skirt comprising an opening for the passage of said voltage supply lead.

Other objects, characteristics and results of the invention will become apparent from the ensuing description given by way of non-limitative example and illustrated by the attached figures in which:

FIG. 1 illustrates a schematic sectional view of part of a klystron equipped with an electrostatic focussing device in accordance with the invention;

FIG. 2 is a sectional view on X of part of FIG. 1;

FIG. 3 is a fragmentary sectional view of part of FIG. 1, in accordance with a variant embodiment; and,

FIGS. 4, 5, 6 and 7 are simplified sectional views equivalent to that of FIG. 2, illustrating different embodiments of the device in accordance with the invention.

FIGS. 1 and 2 illustrate an embodiment of a focussing device in accordance with the invention, applied to a klystron. It goes without saying that this kind of device can be applied to other kinds of microwave tubes and even to other kinds of equipment than such tubes; it can be utilised in any equipment which requires accurate focussing of an electron beam whose axis is fixed in relation to the envelope or enclosure through which it is propagating.

In FIG. 1, a section through a drift space 1 between two cavities 2 and 3, of a klystron, has been illustrated. The axis AB designated both the beam axis (the beam has not been shown) and the direction of propagation of the beam. The walls constituting the two cavities of the klystron and the envelope surrounding the drift space 1, are made of metal and are at a reference potential which is for example the earth potential. The passage of the electron beam along the axis AB, between cavities and drift space, takes place through the openings 4 and 5.

FIG. 2 schematically illustrates a view of this drift space 1 as it appears after making section along X (FIG. 1) and removing all the part to the left of X.

A consideration of these two figures where similar references correspond to similar elements, will show how an embodiment of the focussing device in accordance with the invention is arranged.

An electrostatic lens is constituted in a manner known per se, by a metal annular electrode 6 cooperat-

ing with the body of the tube and forming a solid of revolution therewith. Said electrode, for example of toroidal form, is centered on the axis AB by a fixing system forming part of the invention, and is brought to a negative potential in relation to the reference potential hereinbefore referred to, by voltage supply means 9 described hereinafter.

The system for fixing the electrode 6 to the cylindrical envelope 10 comprises a flexible skirt 11 of cylindrical form, constituted for example by a thin copper sheet profiled in the manner indicated by its section 12 (FIG. 1) and brazed by its edges to the interior of the metal envelope 10 in which the focussing electrode 6 is arranged. Said skirt 11 is opened over part 13 of its periphery in order to pass the voltage supply lead 9; this opening, of course, corresponds with the voltage supply connection 14 assembled on the body of the tube. It should be noted that the profile of the section 12 of the skirt 11 can differ from that shown in FIG. 2; in all cases, it must be such that the skirt has adequate flexibility. FIG. 3 illustrates a variant embodiment of this profile, which is simple to create.

The system of fixing the electrode 6 comprises, furthermore, two rods 15 and 16 which are cylindrical in the embodiment shown in FIGS. 1 and 2. These rods are attached to the electrode 6 at two diametrically opposite points by two components 7 and 8 which are integral with the electrode and each provided with a hole whose axis is perpendicular to the axis AB. The axes of said holes are substantially parallel with one another and the two rods 15 and 16 each passes through one of said holes in the respective components 7 and 8. These two rods are constituted by a rigid material which is a good electrical insulator, for example alumina, and are rigidly attached to the components 7 and 8 by brazing for example.

The points of attachment of the rods 15 and 16 to the skirt 11 and the length of these rods are chosen so that the axis of the electrode 6 coincides accurately with the axis AB of the envelope 10 forming the drift space 1. In the example described, where the two rods 15 and 16 are equidistant from the axis of the electrode 6, the rods have the same length.

The voltage supply lead 9, which can be applied at any point on the electrode 6, will here advantageously be connected to one of the two components supporting the rods, for example the component 7 which is then made up of conductive material which may be the same as that constituting the electrode 6, e.g. stainless steel. In some manufacture embodiments, the components 7 and 8 can form part of the electrode itself; in others, they are attached thereto and soldered or brazed in position.

As FIG. 1 indicates, the voltage is applied to the electrode 6 through a metal wire 17 located in a metal tube 18, the wire being brazed or soldered to the component 7 at one of its ends and to the metal tube 18 at its other end. The tube 18 is inserted with one end in the component 7 whose top part is provided with a recess 19 for this purpose; its other end is connected to an insulating pot 20 which surrounds it in order to provide good insulation of the negative voltage supplied to the electrode 6, which voltage may be very high in relation to the reference voltage of the body of the klystron. The diameter of the metal tube 18 is chosen so as to minimize the electric field produced in the envelope 10 between said tube and the body of the klystron.

A connection 14 which has not been described here in a detailed way, but which can be of any known kind, is used to attach the pot 20 to the klystron body.

As already mentioned, the tube 18 constituting the voltage supply lead 9 passes through the open part 13 of the skirt 11.

An electrostatic focussing device such as that described, has several important advantages.

One advantage is that all the components constituting the system used to attach the electrodes 6 to the envelope 10, are connected together by soldering or brazing. The risk in the variation of the relative positions, is thus virtually eliminated, even in the presence of vibration. As already pointed out, these rigid connections run no risk of effecting the centering of the electrode even during the stoving of the tube. In other words, the flexibility of the skirting 11 enables it to absorb the distortions and differential expansions of these components, for example the electrode 6 and the rods 15 and 16. If the centering of the electrode 6 on the axis AB of the klystron is accurately established at the time of assembly, then it will remain so during the various phases of manufacture of the tube and during operation thereof; thanks to the flexibility of the skirt 11, this centering will be maintained even if the tube is used in airborne equipment subjected to vibration.

However, the accuracy of the centering at the time of assembly is quite an easy matter to arrange. In other words, the electrode 6, the rods 15 and 16 and the skirt 11 constitute a sub-assembly which can be mechanically set prior to assembly in the envelope 10, and then subsequently brazed or soldered in position in said envelope. At this moment, the centering of the electrode 6 on the axis AB can be effected simply and accurately with the help of a gauge block for example which cooperates with the envelope 10 and the internal diameter of the electrode 6.

Another advantage of this device is that the components which make up the fixing system, are simple and consequently inexpensive.

It should be noted that this kind of focussing device and its voltage supply system have much higher resonance frequencies than the prior art ones which are generally heavier. This makes them particularly relevant to application in airborne equipment.

FIGS. 4, 5, 6 and 7 illustrate in a highly schematic manner equivalent views to that of FIG. 2 (section X in FIG. 1) of other embodiments of the device in accordance with the invention. In these figures, references identical to those of FIG. 2, indicate identical elements.

In the embodiment of FIG. 4, the cylindrical rods 15 and 16 are replaced by grooved rods 31, 32 in order to increase the distance obtained between the electrode 6 and the skirt 11 over the surface of the rods 31 and 32, thus lengthening the pass of the leakage currents and improving the breakdown voltage conditions. In this case, the components 7 and 8 no longer contain a cylindrical hole but are slotted; as in the preceding cases, the rods are soldered or brazed to these components.

In FIGS. 5 and 6, cylindrical rods 15 and 16 of FIG. 2 have been replaced by flat components 40 and 50 of rigid insulating material such as alumina, soldered or brazed to the skirt 11 and directly attached, likewise by soldering or brazing, to the electrode 6. The shape of these components is such that the distance between the electrode and the skirt over their surface, is as long as

possible in order to improve the voltage breakdown stability. In these two examples, the voltage supply lead 9 again takes the form, as before, of a wire inside a metal tube, the tube being inserted into a metal component, respectively 41 and 51, part of which, respectively 42 and 52, is attached by soldering or brazing, to the electrode 6.

In the embodiment shown in FIG. 7, the technology used to manufacture the electrode 6 is different. This time, an insulating plate 60 of alumina for example, is machined centrally in accordance with the toroidal form of the electrode, the electrode being constituted by a conductive deposit 63, metallic for example, having a thickness of some few tenths of a millimeter, applied to the toroidal zone. The voltage can be supplied at 9, as before, to a metal component 61 attached to the plate 60 and electrically connected to the deposit 63 which constitutes the electrode, by a metallized zone 62 for example. The plate 60 is machined in order to increase the length of the path of the leakage currents; it is for example pierced by slots such as those 64.

What I claim is:

1. An electrostatic device for focussing an electron beam propagating within an envelope along an axis which is fixed in relation to said envelope which constitutes a surface of revolution around the axis of said beam, comprising:
 - an annular electrode having applied thereto a potential which is negative in relation to said envelope by means of a voltage supply lead penetrating within said envelope; and
 - a system for fixing said electrode to said envelope in an electrically insulated relationship from one another, said electrode being centered with respect to the axis of the electron beam, said system comprising:
 - a flexible cylindrical skirt attached to the interior of said envelope around the axis of the electron beam, said skirt exhibiting a profiled section in planes containing said axis, the edges of said skirt being attached to said envelope whereby the skirt is elastically deformable between its edges; and
 - components of rigid insulating material attached on the one hand to the said electrode, and on the other hand to said skirt between the said two edges, said skirt further having an opening therein for the passage of said voltage supply lead.
2. A focussing device according to claim 1, wherein said components made of rigid insulating material are constituted by two cylindrical rods having the same length, fixed at their mid-points to the electrode by means of two pieces which are themselves attached onto two diametrically opposite points of said electrode, said two pieces being each provided with a hole whose axis is perpendicular to the axis of said electrode, the two rods passing respectively through said two holes where they are rigidly fixed to the said two pieces in order to be parallel with one another and symmetrical in relation to the axis of the electrode and

being furthermore rigidly attached by their ends to said skirt.

3. A focussing device according to claim 2, wherein at least one of the two said pieces in which the two cylindrical rods are fixed, is of a conductive material, located in front of said opening of said skirt, and connected to said voltage supply lead.

4. A focussing device according to claim 2 wherein said two rods of rigid insulating material are grooved, the two holes in which they are inserted and fixed into the said two pieces which are attached to the electrode, being open over part of their peripheries.

5. A focussing device according to claim 1 wherein said components of rigid insulating material are constituted by a flat plate disposed perpendicularly to the axis of said electrode and attached rigidly on the one hand to said skirt and on the other to said electrode which said skirt maintains centered onto the axis of said electron beam.

6. A focussing device according to claim 5 wherein said flat plate is cut out in order to increase the path for the leakage currents between said electrode and said skirt.

7. A focussing device according to claim 1, wherein said components of rigid insulating material comprise a flat plate arranged perpendicularly to the axis of the electron beam and rigidly attached to said skirt, said electrode including a film of conductive material deposited onto a toroidal zone machined at the center of said flat plate.

8. A microwave tube having an electrostatic device for focussing an electron beam propagating within an envelope of said tube along an axis which is fixed in relation to said envelope which constitutes a surface of revolution around the axis of said beam, comprising:

- an annular electrode having applied thereto a potential which is negative in relation to said envelope by means of a voltage supply lead penetrating within said envelope; and
- a system for fixing said electrode to said envelope in an electrically insulated relationship from one another, said electrode being centered with respect to the axis of the electron beam, said system comprising:
 - a flexible cylindrical skirt attached to the interior of said envelope around the axis of the electron beam, said skirt exhibiting a profiled section in planes containing said axis, the edges of said skirt being attached to said envelope whereby the skirt is elastically deformable between its edges; and
 - components of rigid insulating material attached on the one hand to said electrode, and on the other hand to said skirt between the said two edges, said skirt further having an opening therein for the passage of said voltage supply lead.

9. A microwave tube according to claim 8, wherein said tube is a multicavity klystron having a drift space separating the cavities of said klystron, the focussing device being positioned in said drift space.

* * * * *