

P. SETTINO.  
VALVE.

APPLICATION FILED FEB. 25, 1903.

NO MODEL.

2 SHEETS—SHEET 1.

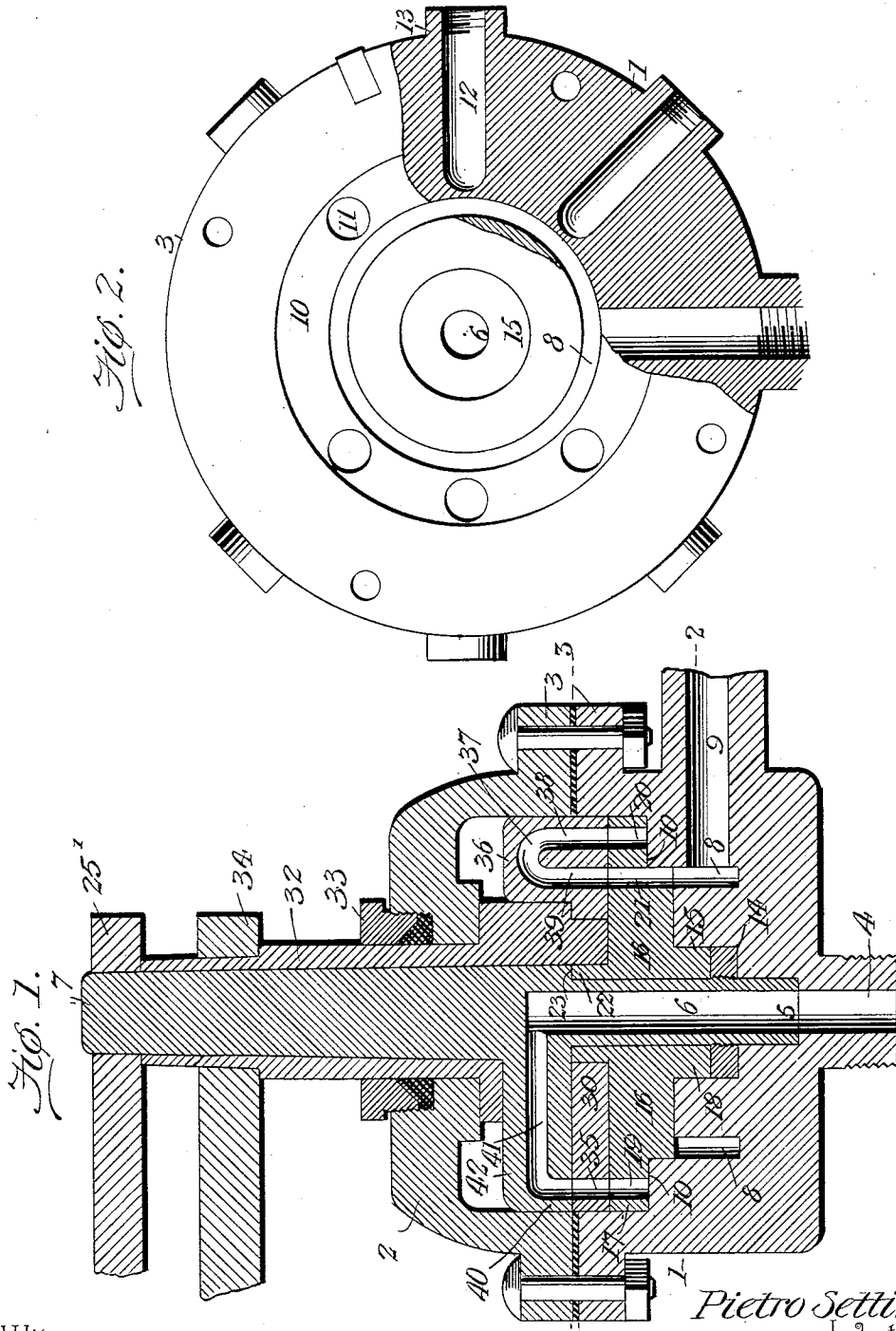

Witnesses  
*E. J. Stewart*  
*Geo. E. Parker*

*Pietro Settino*  
 Inventor  
 by *Chas. H. Snow*  
 Attorneys

P. SETTINO.  
VALVE.

APPLICATION FILED FEB. 25, 1903.

2 SHEETS—SHEET 2.

NO MODEL.

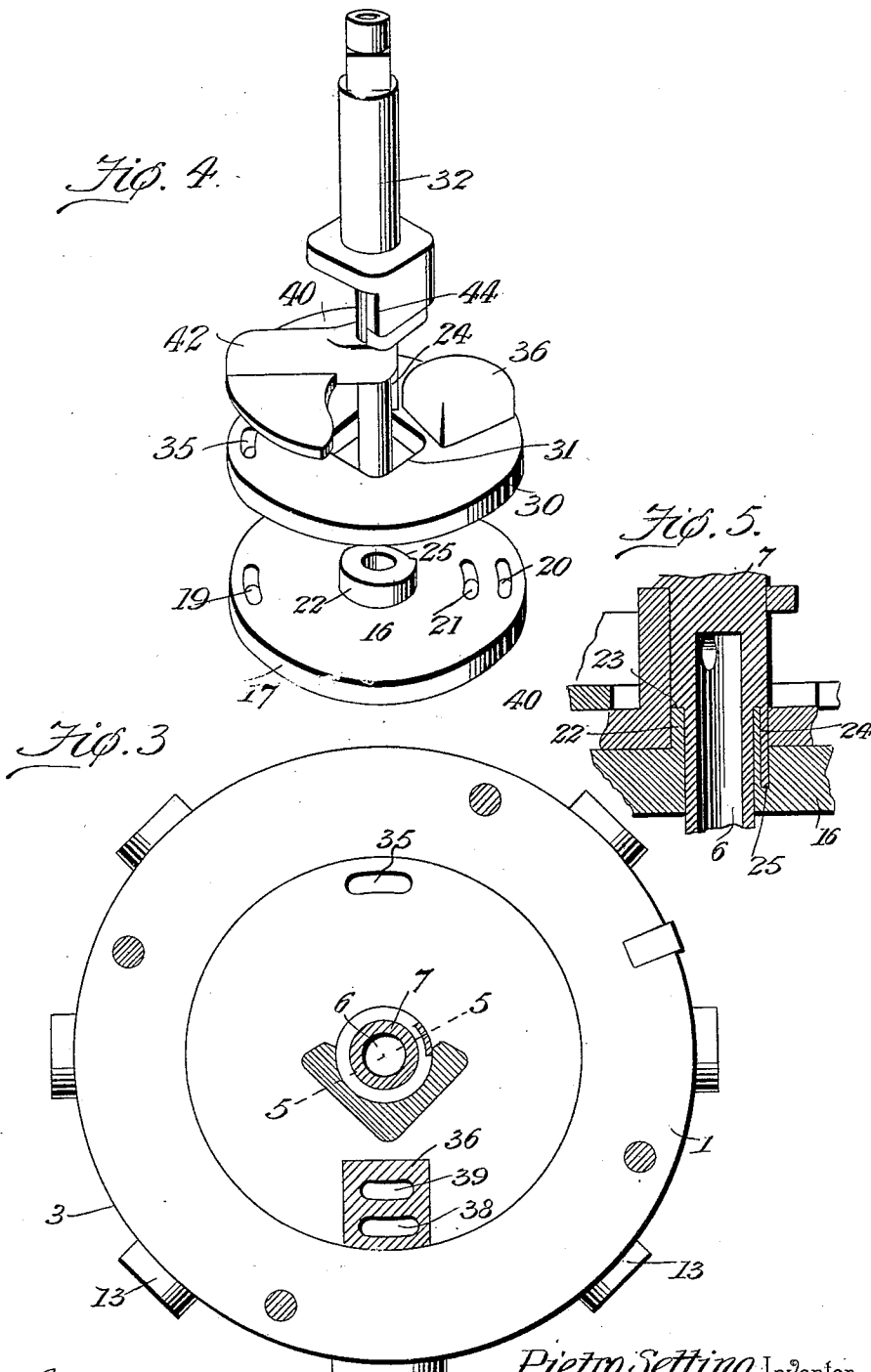

Witnesses  
*E. H. Lewatt*  
*Jno & Parker*

Pietro Settino Inventor  
 by *Chas. Snow & Co.*  
 Attorneys

# UNITED STATES PATENT OFFICE.

PIETRO SETTINO, OF STEELTON, PENNSYLVANIA.

## VALVE.

SPECIFICATION forming part of Letters Patent No. 735,162, dated August 4, 1903.

Application filed February 25, 1903. Serial No. 145,049. (No model.)

*To all whom it may concern:*

Be it known that I, PIETRO SETTINO, a citizen of the United States, residing at Steelton, in the county of Dauphin and State of Pennsylvania, have invented a new and useful Valve, of which the following is a specification.

This invention relates to certain improvements in valves, and particularly to that class of valves for controlling the flow of fluids in a number of directions—as, for instance, in the flow of water or other fluid to and from a plurality of cylinders having pistons actuated in opposite directions by the fluid under pressure, although it may be employed for other purposes for directing the flow of fluids in any direction.

A further object of the invention is to provide a simple form of ported valve by which the flow of the fluid may be positively controlled by the operator without loss of any of the fluids or reduction of pressure.

With these and other objects in view the invention consists in the novel construction and arrangement of parts hereinafter described, illustrated in the accompanying drawings, and particularly pointed out in the appended claims, it being understood that various changes in the form, proportions, size, and minor details of the structure may be made without departing from the spirit or sacrificing any of the advantages of the invention.

In the accompanying drawings, Figure 1 is a longitudinal sectional elevation of a valve constructed in accordance with the invention. Fig. 2 is a sectional plan view of the same on the line 2 2 of Fig. 1. Fig. 3 is a similar view on the line 3 3 of Fig. 1. Fig. 4 is a detail perspective view of the more important parts of the valve detached. Fig. 5 is a detail sectional view on the line 5 5 of Fig. 3.

Similar numerals of reference are employed to indicate corresponding parts throughout the several figures of the drawings.

The valve-casing comprises two members 1 and 2, having bolting-flanges 3 for the passage of a number of bolts, by which the two sections may be secured together, a ring of packing material being preferably introduced between the two in order to render the casing water-tight. The section 1 is provided

with a centrally-disposed coupling member 4, to which may be coupled a supply or inlet pipe for the fluid under pressure, and the fluid is introduced into the valve-chamber through an opening 5, communicating with a similar channel or bore 6, formed in a centrally-located valve-stem 7. In the lower section 1 of the casing is an annular groove 8, into which the waste water passes and is discharged through a port or passage 9, which may be connected in any suitable manner to a discharge-pipe, or the fluid may be discharged into any suitable receptacle in accordance with the character of the mechanism with which the device is connected. At the top of the outer wall of the annular groove 8 is a shoulder 10, annular in form, and extending downwardly through this shoulder are a number of openings 11, which communicate with radiating ports or passages 12, which extend out to the periphery of the valve and are connected to coupling members 13 in the form of extensions having internal or external screw-threads for connection with pipes or tubes leading to the cylinders or other vessels with which the valve is connected. In the present instance six ports or passages 12 are shown as a matter of illustration, although it will be understood that the valve may be employed in connection with a greater or a less number, as may be desired, the number of ports being limited only by the size of the valve-casing.

The lower portion of the hollow valve-stem 7, which has been previously referred to, is preferably threaded and receives an internally-threaded collar or disk 14, which may be formed of Babbitt metal or the like, in order to form a packing, and the latter is located in a circular recess 15 at the central portion of the lower member of the casing.

16 designates a valve-disk fitting within the upper portion of the annular groove 8 and forming a closure therefor, said disk being provided with an enlarged annular flange 17, which fits over the shoulder or valve-seat 10, and at the center of the disk is a hub 18, fitting within the circular recess 15 and bearing against the upper surface of the packing-ring 14. The valve-disk 16 is provided with three ports or passages 19, 20, and 21, extending completely through the disk and all ar-

ranged in the same diametral line. The ports 19 and 20 are so arranged as to be brought into alinement with the several vertically-disposed ports 11, which communicate with the radial ports 12, while the port 21 communicates with the annular groove 8 and thence with the discharge-port 9. The construction is such that the port 21 is at all times and under all circumstances in free communication with the annular groove 8, so that any fluid passing through said port can flow directly through the discharge-port 9. Extending from the central portion of the upper face of the valve-disk 16 is an annular flange or hub member 22, and resting on this is an annular shoulder 23, formed on the valve-stem 7. The valve-stem 7 has a depending finger or lug 24, which extends through an opening 25, formed in the valve-disk, a portion of the opening being formed by cutting away the outer wall of the flange or collar 22. This connection serves as a coupling means between the valve-stem and the disk, so that when the valve-stem is turned by its operating-lever 25' the lower valve-disk will also be moved and may be traveled until the ports are in communication with the vertical ports 11 or may be stopped at any point between adjacent ports in order to entirely cut off the flow of water or other fluid through the valve-casing.

Mounted above the valve-disk 16 is a second disk 30, having a centrally-disposed opening 31 of square or polygonal form and adapted to receive the lower end of a tubular valve-stem 32, the lower end of this valve-stem being cut away for a portion of its circumference, but retaining at least two of its angular walls, which fit within the opening 31 and when turned permit the turning movement of the valve-disk 30 independent of the lower disk 16. The tubular valve-stem 32 passes through a suitable stuffing-box 33 and at its upper end is provided with a suitable operating handle or lever 34. The valve-disk 30 is provided with a port or passage 35, which may be placed in communication with the corresponding port 19 of the lower disk 16, and said upper disk is further provided with an enlarged boss 36, in which is formed a port or channel 37, opening at 38 and 39 at the lower face of the valve-disk, these openings being adapted to communicate with the ports 20 and 21, respectively, of the lower valve-disk 16.

Mounted above the disk 30 is a valve disk or segment 40, which is secured to and rotates with the valve-stem 32, and the upper portion of said segment is enlarged to form a radially-disposed port 41, communicating at its inner end with the central passage 6 of the valve-stem and at its outer end opening at the lower face of the segment at a distance from the center of rotation corresponding to that of the ports 19 and 35, so that it may be placed in communication with these ports to permit the water or other fluid entering through the passage-way 5 of the spindle to pass through the several ports of the valve-disks to any one of

the ports 11 and from thence to the different radiating ports 12, leading to the pipes. The enlarged portion of the disk 40 is in the form of a radiating rib 42, which plays between the vertical walls 44 formed by cutting away the lower portion of the hollow valve-stem 32 and these walls forming a stop for limiting the movement of the segment and the lower valve-disk 16 in both directions.

It will be noted that the segment 40 and the lower valve-disk 16 are both connected to and rotate with the central valve-stem 7, while the central disk 30 is secured to and is movable independently by the valve-stem 32 and its operating-handle. The inlet-ports 19, 35, and 41 are arranged at one side of the disks, while the corresponding escape-ports 20, 21, 38, and 39 are disposed in the same diametral line at the opposite side of the disk, and the coupling members 13, to which the several fluid-pipes are connected, are disposed in diametral alining pairs, so that when the valve is moved into alinement with any one or other of the pairs of ports the fluid will pass from the supply-pipe through the central channel 5, the port 41, port 35, port 19 to any one of the ports 11 and its radiating ports 12 to the cylinder or other device with which the valve is connected, while the waste water or return from corresponding source will enter the diametrically opposed port 12 and pass upwardly through the corresponding port 11, through port 20, port 38, port 39, port 21 to the annular groove 8, and thence through the discharge-pipe 9, or in some cases the discharge-pipe 9 may be used as the supply member, while the port of the central spindle 7 may serve as the discharge outlet. When it is desired to place the water pressure and exhaust connections consecutively in communication with a number of cylinders or other devices, the two handles or levers 25' and 34 are grasped and moved; but under ordinary circumstances it is preferred to operate the valve in the following manner: Supposing the valve members to be in such position as to place diametrically alining ports 11 in proper communication for the supply and exhaust of the water or other fluid and it is desired to stop the flow, the handle 25' is grasped and turned to its fullest extent or until the edge of the radiating rib 42 comes into contact with one of the vertical walls 44 at the lower portion of the valve-stem 32. This moves the ports 19, 20, 21, and 41 into position immediately above the second pair of diametrically alining ports 11, but of course shuts off the flow of water through the valve-casing, as the centrally-disposed valve-disk 31 remains in place and its ports are out of alinement with those of the other members. The second handle or lever 34 is then grasped and turned until it is disposed below and in the same radial line with the upper handle, thus placing the several ports in communication and establishing a new circulation through a second cylinder or other de-

vice. By this means it becomes unnecessary to place any designating marks on the upper or outer face of the cylinder to indicate the correct positions of the operating-handles; but the casing may be provided with such indicating marks as a matter of precaution, or the coupling members to which the several pipes are connected may serve a similar purpose.

1c The several valve-disks and the segment, together with the seat members, are ground and properly faced in order to form fluid-tight joints, and by preference brass or similar metal is used. When worn or leaking, 15 the upper member of the casing may be readily removed and the valve-disks taken out and reground.

It will be understood that the valve may be employed for use in connection with any desired number of cylinders or other devices, 20 the number being limited only by the size of the casing.

Having thus described the invention, what is claimed is—

25 1. In a valve, a casing having an inlet-port and an exhaust-port and being further provided with a plurality of ports arranged in diametrically opposing pairs, a plurality of superposed ported disks, and concentrically- 30 disposed valve-stems extending out through a single stuffing-box at one side of the valve-casing.

2. In a valve, a casing having a plurality of ports arranged in diametrically opposing 35 pairs and having inlet and exhaust ports for a fluid, a plurality of ported disks disposed one above the other, the upper and lower disks being connected and movable together, and the central disk having a movement inde- 40 pendent of the others.

3. In a valve, a casing having a plurality of ports arranged in diametrically opposing pairs and provided with inlet and exhaust 45 ports for the fluid, a plurality of ported valve members disposed one above the other, a valve-stem connected to two of the valve members, and an independent valve-stem connect- ed to the intermediate member.

4. The combination in a valve, a casing hav- 50 ing ports, a valve-seat into which the ports open, a pair of ported valve members in which the ports are alining, said ports being spaced one from the other and movable simultane- ously, and a third valve member disposed be- 55 tween the two and movable independent thereof.

5. In a valve, an annular valve-seat, a plu- 60 rality of ports opening at the seat, a ported valve-disk bearing on the seat, a second ported valve member spaced from the valve-disk and movable therewith, and an intermediate ported valved member movable independ- ently of the other two.

6. In a valve, a casing having an annular 65 valve-seat, a plurality of ports opening at the seat, a valve-disk mounted on said seat and provided with inlet and escape ports, there

being an annular groove formed in the seat and placing one of the disk-ports in commu- 70 nication with an exhaust-port, a valve-stem having a central channel forming a water-in- let and connected to said disk, a valve-seg- ment having a port or channel communicat- ing with the passage of the stem and having 75 its outlet in alinement with one of the ports of the disk, an intermediate valve-disk hav- ing ports corresponding to those of the lower disk, and a second valve-stem having an in- dependent connection with said intermediate 80 valve-disk.

7. The combination in a valve, of a casing having an annular valve-seat, a plurality of ports opening at the seat, independently-op- 85 erable valve-disks for controlling the flow of the fluid, a central stem connected to one of said valve-disks, a hollow stem encircling the first and connected to a second disk, and means for limiting the movement of one of the stems with respect to the other.

8. In a valve, supply and discharge ports, 90 a plurality of valve-disks, independently-op- erable valve-stems connected to the disks, and means carried by the stems for limiting the movement of one with respect to the other.

9. In a valve, a casing having an annular 95 valve-seat, a plurality of ports opening at the seat, an annular discharge-groove, an escape- port communicating therewith, a centrally- disposed valve-stem having a passage form- ing a fluid-inlet, a valve-disk mounted on the 100 seat and provided with diametrically oppos- ing ports for governing respectively the inlet and escape of the fluid, a second disk mount- ed on the first and movable independently 105 thereof, said second disk having ports corre- sponding to those of the first disk, and a port- ed valve-segment mounted on the second disk and connected to the valve-stem of the first disk, the port of said segment communicating 110 at one end with the passage of the stem and at its opposite end communicating with the corresponding ports of the two disks.

10. In a valve, a two-part casing one of the members of which is provided with an annu- 115 lar valve-seat and an annular groove, a dis- charge-port in communication with the lat- ter, a valve-disk mounted on the seat and provided with diametrically opposing ports, a valve-segment spaced from the disk and provided with a radially-arranged port, a 120 valve-stem connected to both the disk and the segment and having a central passage for fluid, said passage being in communication with the radiating port of the segment, an intermediate ported disk disposed between 125 the first disk and the segment, a hollow stem carrying said intermediate disk and sur- rounding the first stem, and independent op- erating-levers connected to said stems.

11. The combination in a valve, of a two- 130 part casing one of the members of said casing being provided with an annular valve-seat, a plurality of ports opening at the valve-seat, an annular groove formed in that member

having a valve-seat and communicating with  
a discharge-opening, a centrally-disposed  
spindle having a passage for the inlet of a  
fluid under pressure, a valve-disk mounted  
5 on the seat and provided with diametrically  
opposing inlet and escape ports, a valve-seg-  
ment having a radially-arranged port com-  
municating at its inner end with the passage-  
way of the stem and at its outer end being  
10 disposed in alinement with one of the ports  
of the disk, an intermediate ported disk dis-  
posed between the first disk and the seg-  
ment, there being a slotted connection between the  
stem and the lower disk, a hollow valve-stem  
15 surrounding the first stem and having a rec-

tangular portion adapted to a similarly-  
shaped opening in the intermediate disk, the  
rectangular portion being cut away to form  
a pair of stop-shoulders for limiting the move-  
ment of the segment and lower disk, and in- 20  
dependent operating-levers connected to the  
two stems.

In testimony that I claim the foregoing as  
my own I have hereto affixed my signature in  
the presence of two witnesses.

PIETRO SETTINO.

Witnesses:

E. M. SNAVELY,  
ISRAEL N. BUSER.