

No. 646,266.

Patented Mar. 27, 1900.

S. DIESCHER.

APPARATUS FOR PICKLING OR CLEANING METAL SHEETS.

(Application filed July 26, 1899.)

(No Model.)

14 Sheets—Sheet 1.

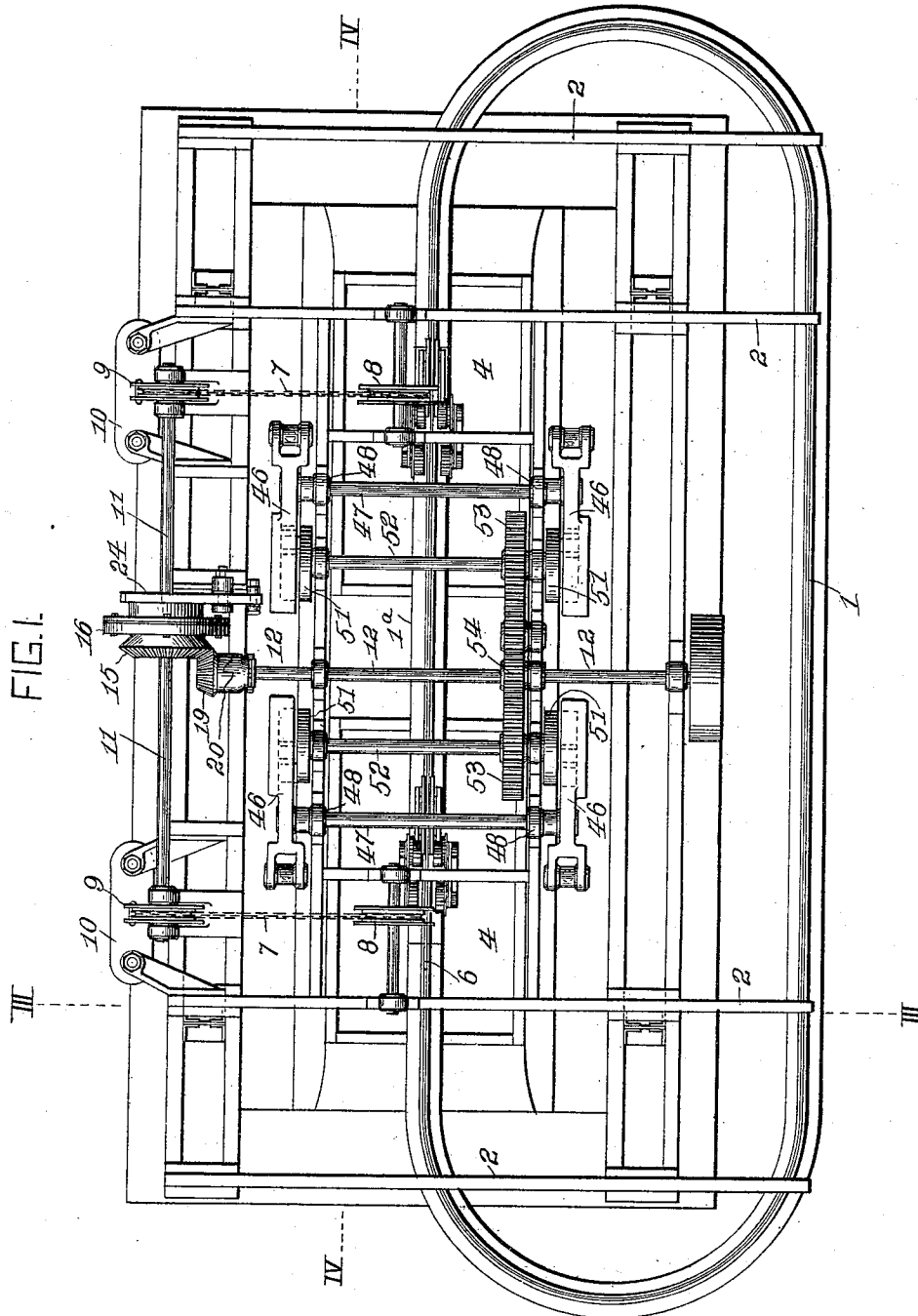

WITNESSES:

*Herbert Bradley*  
*A. E. Gaither*

INVENTOR,

*Samuel Diescher*  
by *Darius B. Wolcott*

Att'y.

No. 646,266.

Patented Mar. 27, 1900.

S. DIESCHER.

APPARATUS FOR PICKLING OR CLEANING METAL SHEETS.

(No Model.)

(Application filed July 26, 1899.)

14 Sheets—Sheet 2.

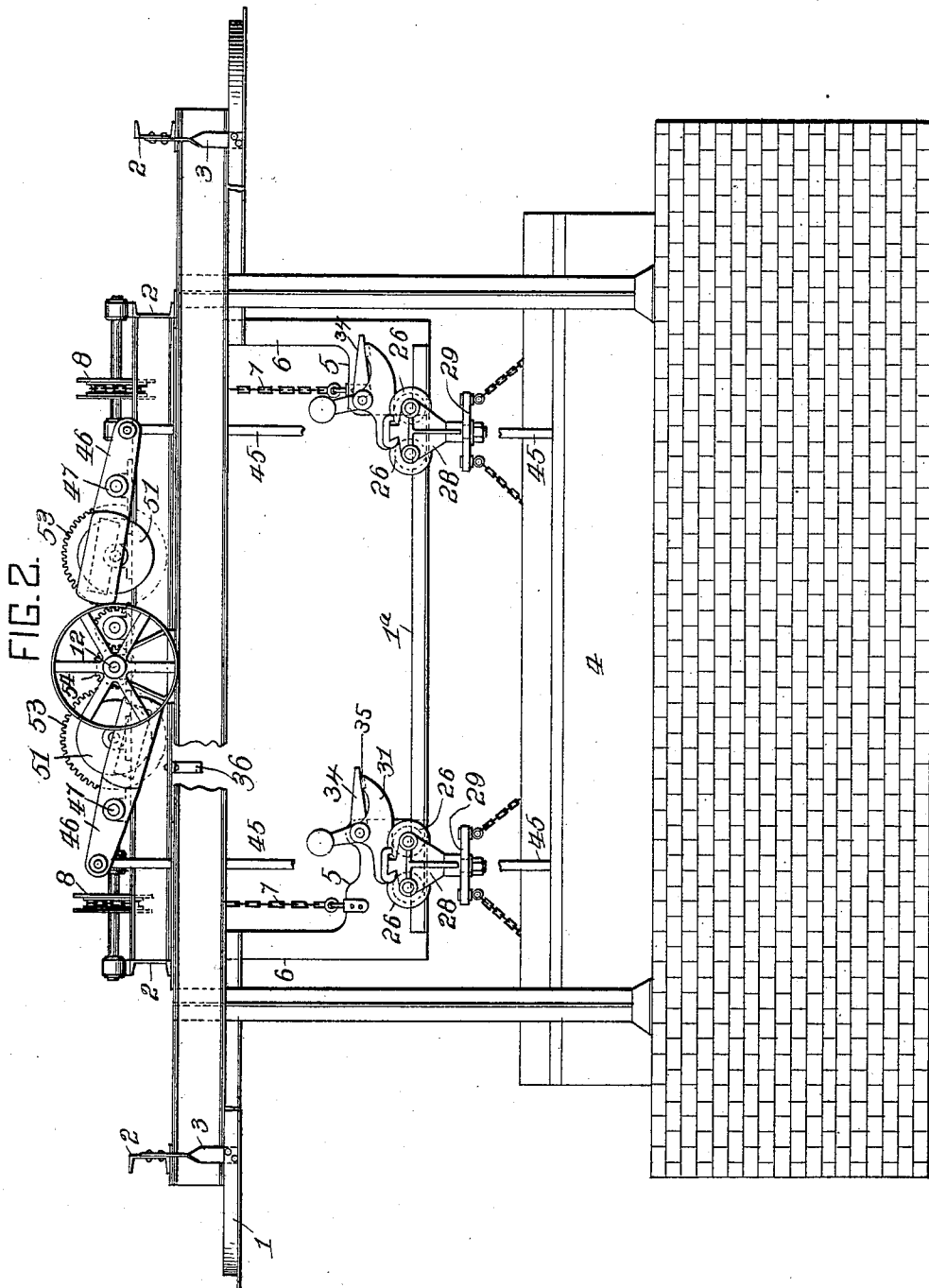

WITNESSES:  
*Herbert Bradley*  
*J. E. Gaither*

INVENTOR,  
*Samuel Diecher*  
*by Danrie S. Wolcott*  
Att'y.

S. DIESCHER.

APPARATUS FOR PICKLING OR CLEANING METAL SHEETS.

(No Model.)

(Application filed July 26, 1899.)

14 Sheets—Sheet 3.

FIG. 3.

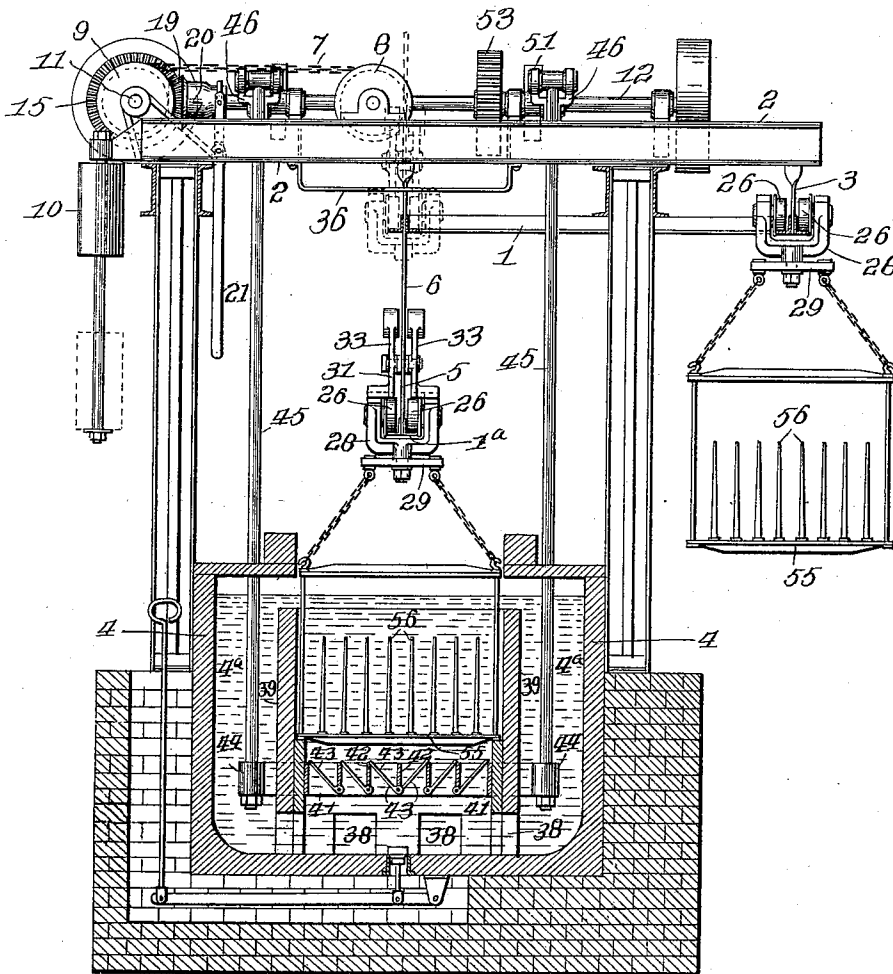

WITNESSES:

*Herbert Bradley*  
*A. E. Gaither*

INVENTOR,

*Samuel Diescher*  
by *Darius B. Wolcott*  
Att'y.

No. 646,266.

Patented Mar. 27, 1900.

S. DIESCHER.

APPARATUS FOR PICKLING OR CLEANING METAL SHEETS.

(No Model.)

(Application filed July 26, 1899.)

14 Sheets—Sheet 4.

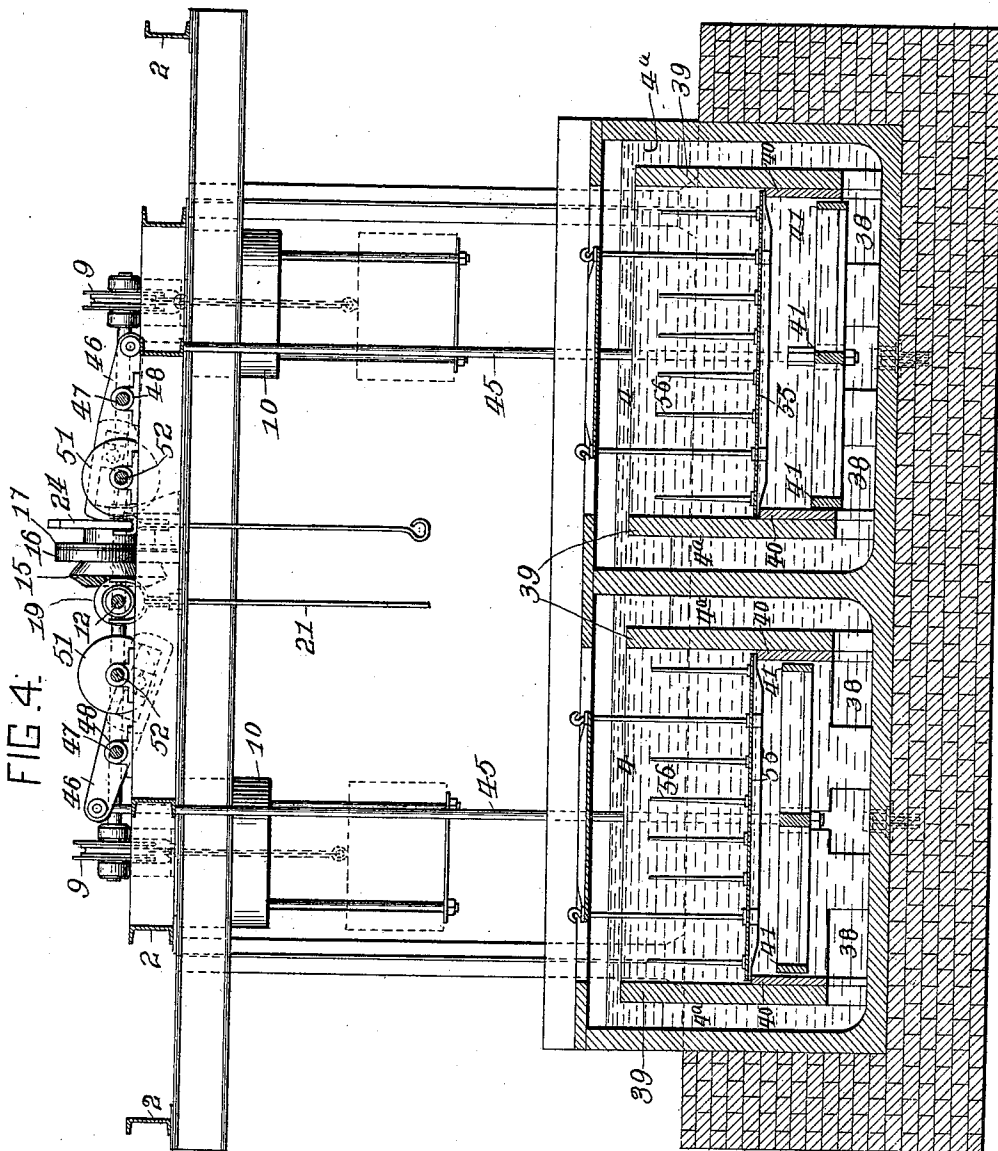

WITNESSES:

*Herbert Bradley*  
*J. C. Gaither*

INVENTOR,

*Samuel Diescher*  
by *Darius S. Wolcott*

Att'y.

No. 646,266.

Patented Mar. 27, 1900.

S. DIESCHER.

APPARATUS FOR PICKLING OR CLEANING METAL SHEETS.

(No Model.)

(Application filed July 26, 1899.)

14 Sheets—Sheet 5.

FIG. 5.

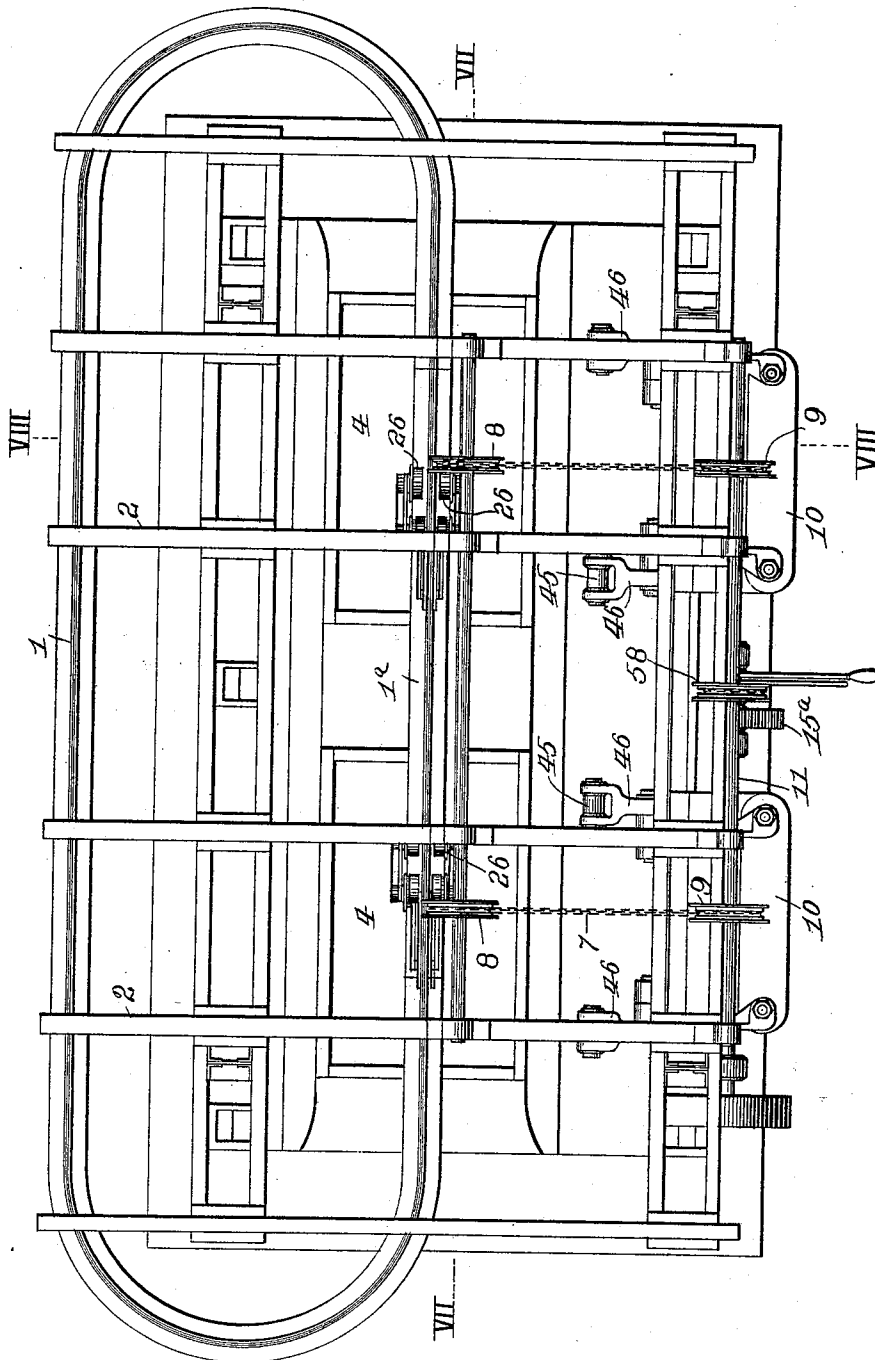

WITNESSES:

*Herbert Madley*  
*J. E. Gaither*

INVENTOR.

*Samuel Diescher*  
by *Darius S. Wolcott*  
Att'y.

S. DIESCHER.

APPARATUS FOR PICKLING OR CLEANING METAL SHEETS.

(Application filed July 26, 1899.)

(No Model.)

14 Sheets—Sheet 6

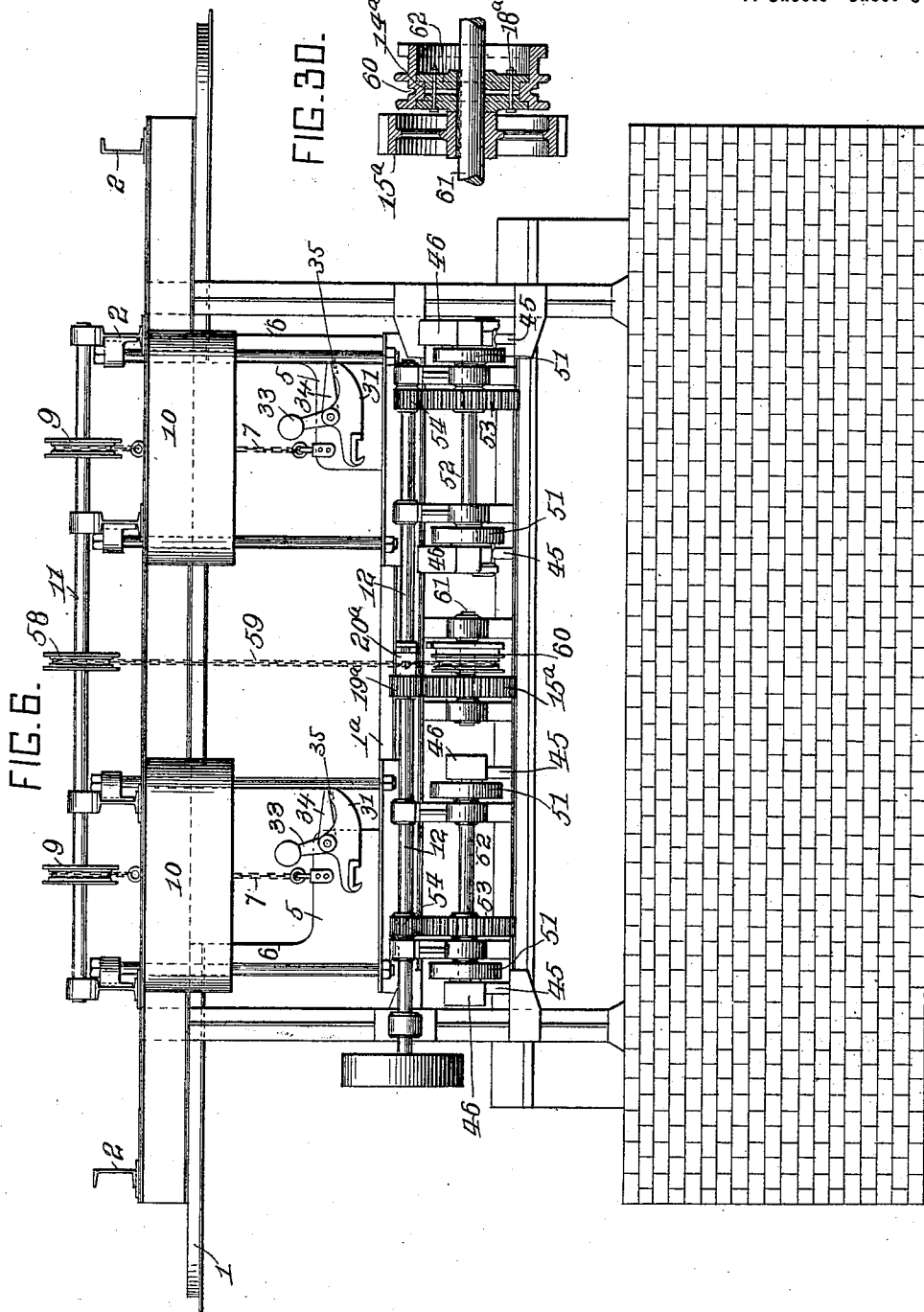

WITNESSES:  
*Herbert Bradley*  
*J. E. Gauthier*

INVENTOR,  
*Samuel Diescher*  
 by *Darius S. Wolcott*

Att'y.

S. DIESCHER.

APPARATUS FOR PICKLING OR CLEANING METAL SHEETS.

(Application filed July 26, 1899.)

(No Model.)

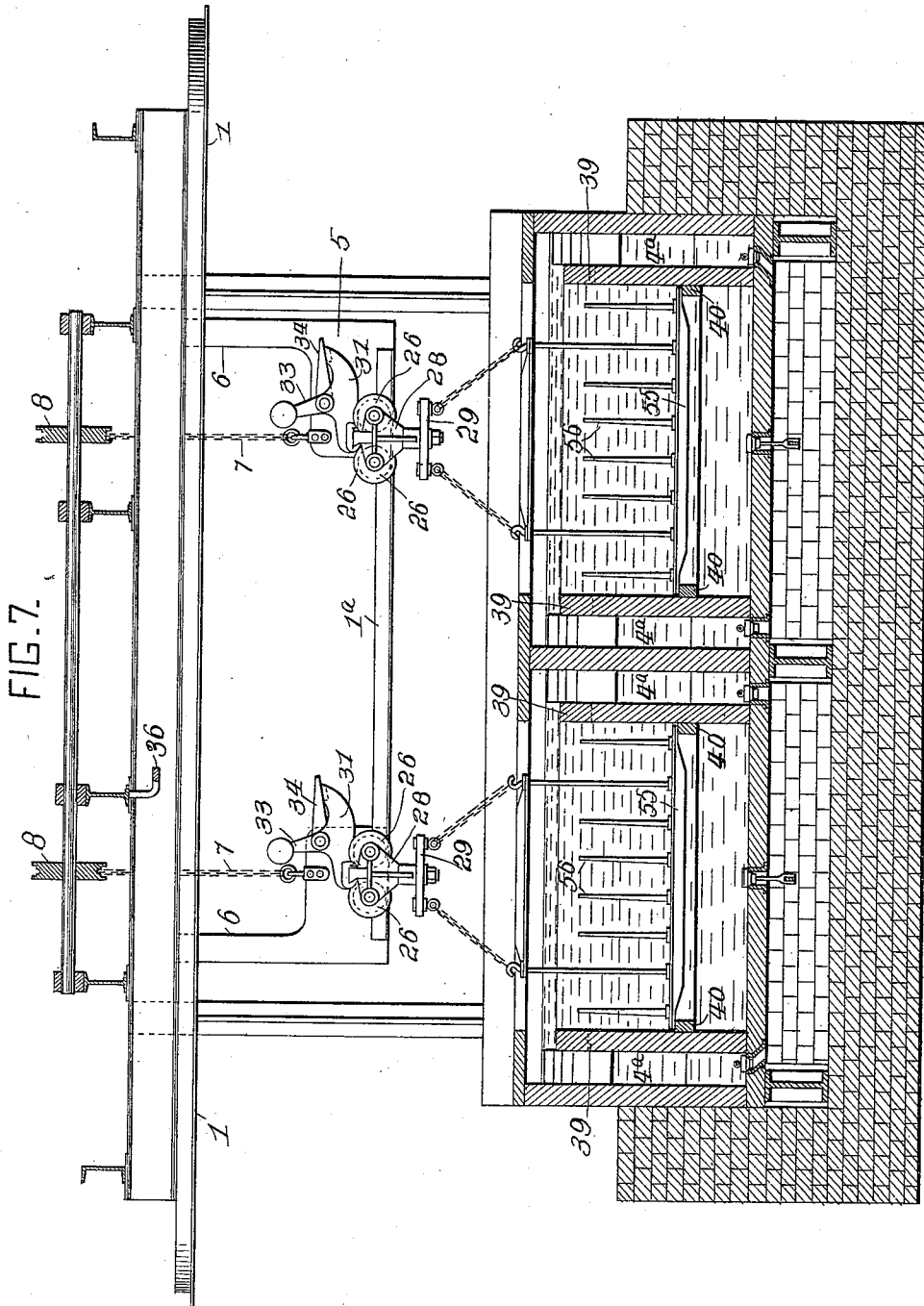

FIG. 7.

WITNESSES:

*Herbert Bradley*  
*J. E. Gaither*

INVENTOR,

*Samuel Diescher*  
by *Darius S. Wolcott*

Att'y.

No. 646,266.

Patented Mar. 27, 1900.

S. DIESCHER.

APPARATUS FOR PICKLING OR CLEANING METAL SHEETS.

(No Model.)

(Application filed July 26, 1899.)

14 Sheets—Sheet 8.

FIG. 8.

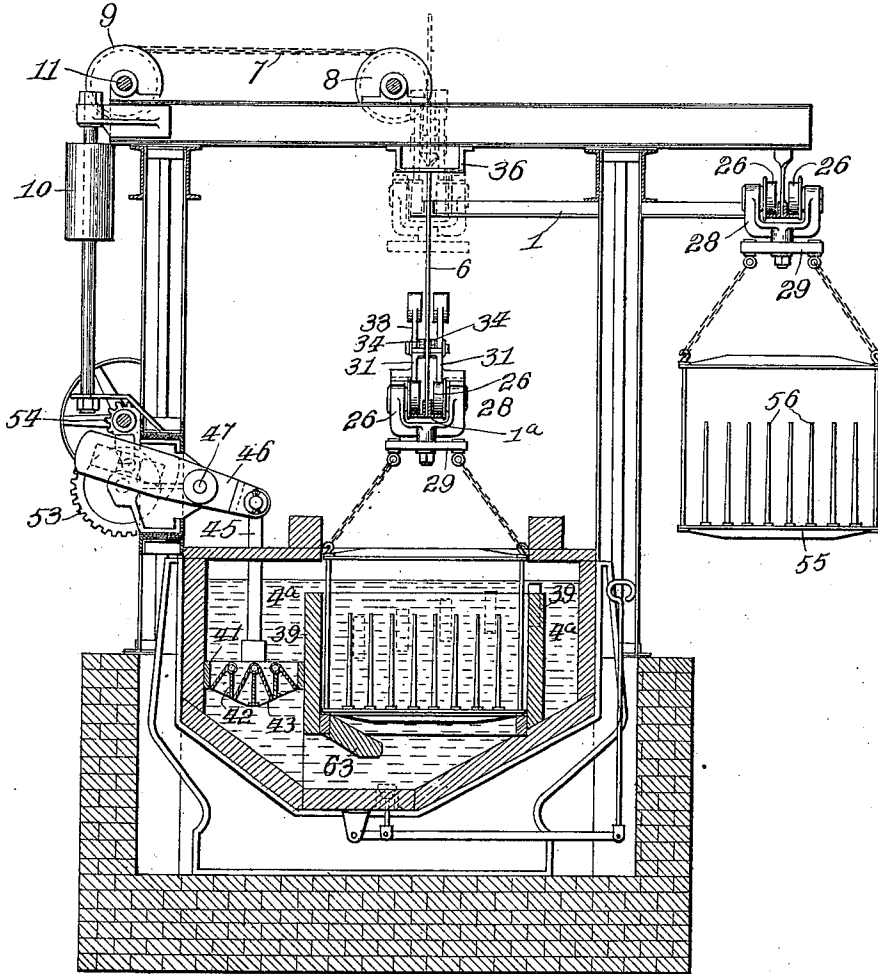

WITNESSES:

*Herbert Bradley*  
*A. O. Gaicher*

INVENTOR,

*Samuel Diescher*  
by *Darius B. Wolcott*

Att'y.

S. DIESCHER.

APPARATUS FOR PICKLING OR CLEANING METAL SHEETS.

(No Model.)

(Application filed July 26, 1899.)

14 Sheets—Sheet 9.

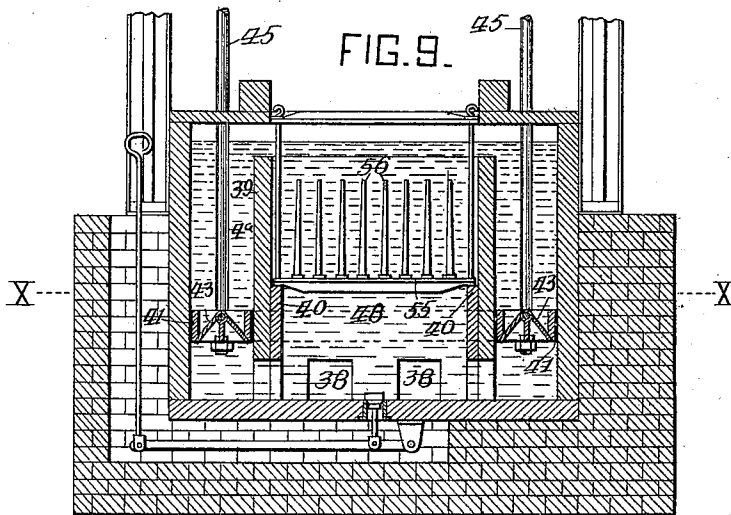
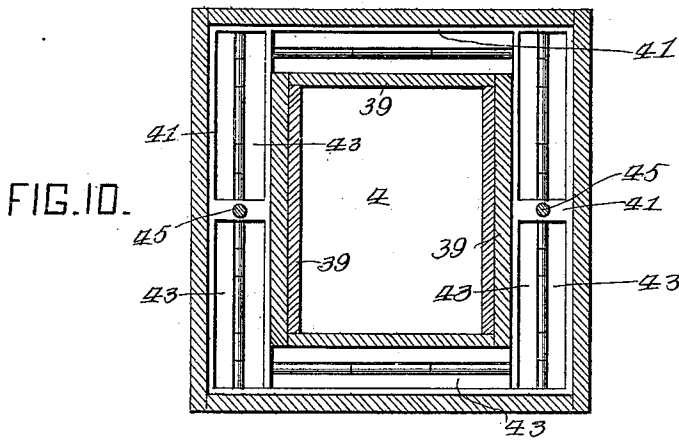

WITNESSES:

*Herbert Bradley*  
*J. E. Gaicher*

INVENTOR,

*Samuel Diescher*  
by *Darius S. Wolcott*  
Att'y.

No. 646,266.

Patented Mar. 27, 1900.

S. DIESCHER.

APPARATUS FOR PICKLING OR CLEANING METAL SHEETS.

(No Model.)

(Application filed July 26, 1899.)

14 Sheets—Sheet 10.

FIG. 11.

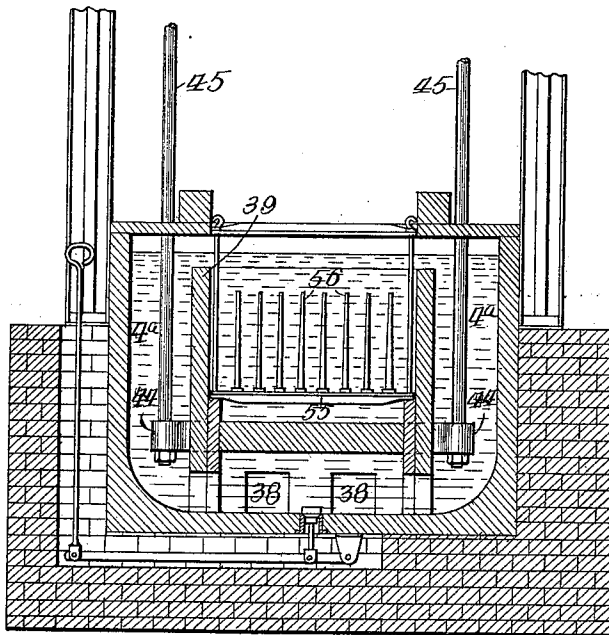

WITNESSES:

*Herbert Bradley*  
*A. C. Gaither*

INVENTOR,

*Samuel Diescher*  
*by Samuel S. Wolcott*

Att'y.

No. 646,266.

Patented Mar. 27, 1900

S. DIESCHER.

APPARATUS FOR PICKLING OR CLEANING METAL SHEETS.

(No Model.)

(Application filed July 26, 1899.)

14 Sheets—Sheet II.

FIG. 13.

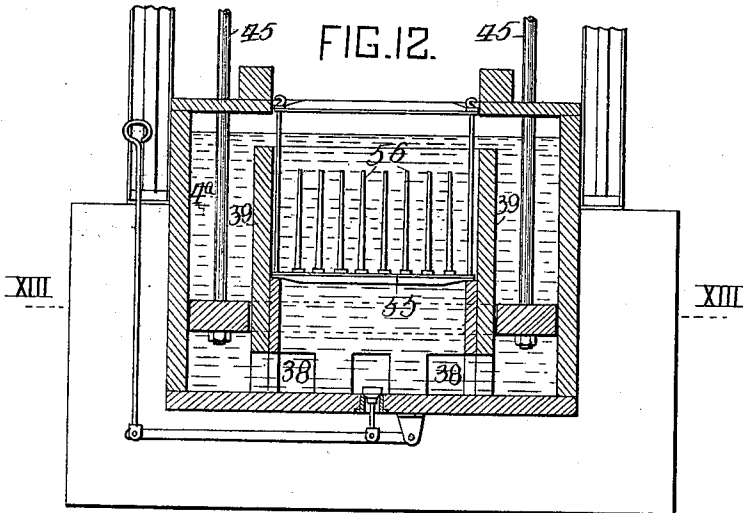
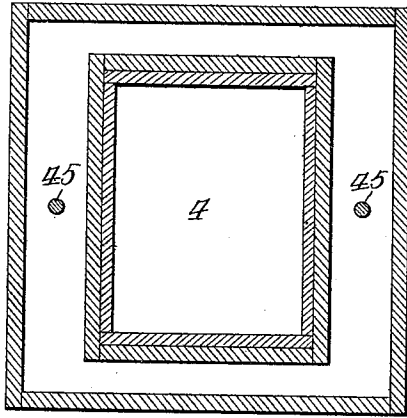

WITNESSES:

*Herbert Bradley*  
*F. E. Gaither*

INVENTOR,

*Samuel Diescher*  
by *Samuel B. Wolcott*  
Att'y.

S. DIESCHER.

APPARATUS FOR PICKLING OR CLEANING METAL SHEETS.

(Application filed July 26, 1899.)

(No Model.)

14 Sheets—Sheet 12.

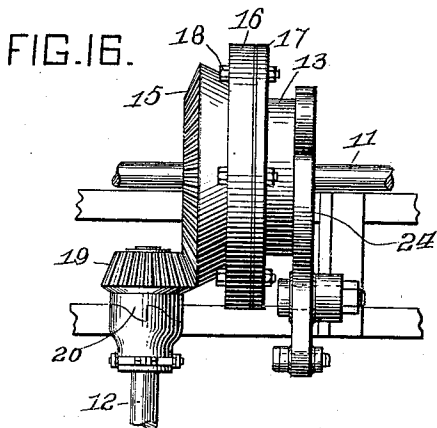
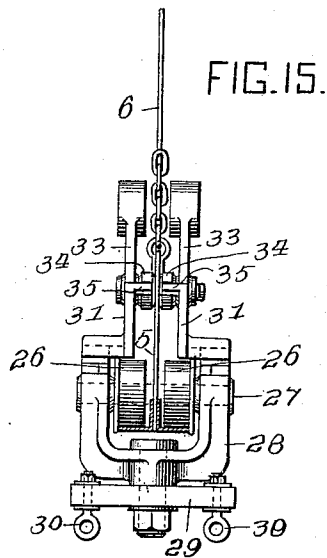
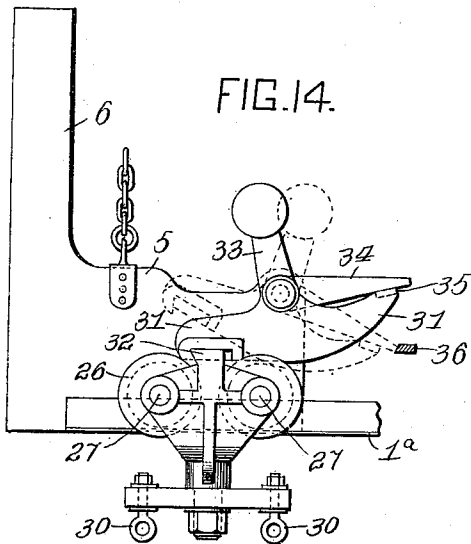
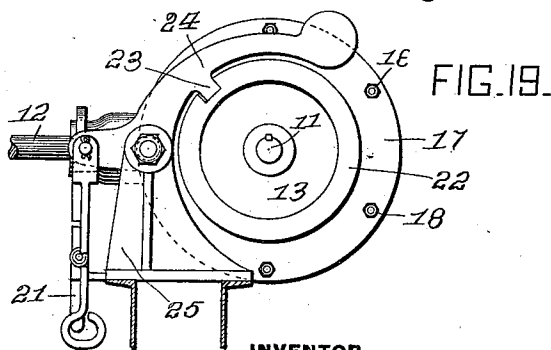
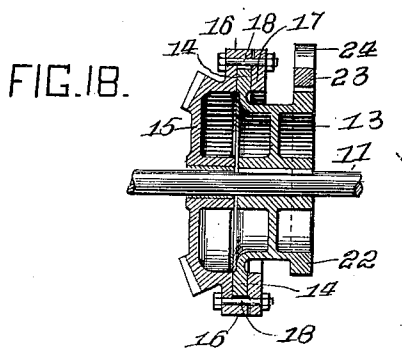
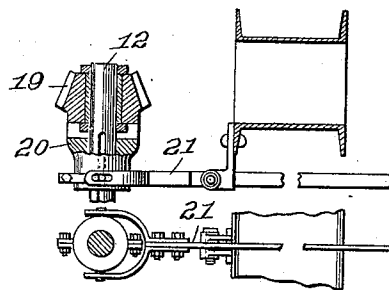

FIG. 17.



WITNESSES:

*Herbert Bradley*  
*J. E. Gaither*

INVENTOR,

*Samuel Diescher*  
by *Danvers Wolcott*

Att'y.

S. DIESCHER.

APPARATUS FOR PICKLING OR CLEANING METAL SHEETS.

(No Model.)

(Application filed July 26, 1899.)

14 Sheets—Sheet 13.

FIG. 20.

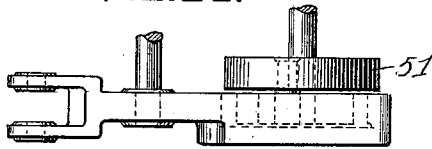

FIG. 21.

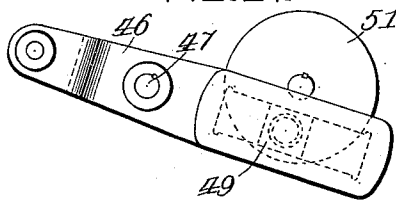

FIG. 22.

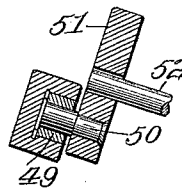

FIG. 23.

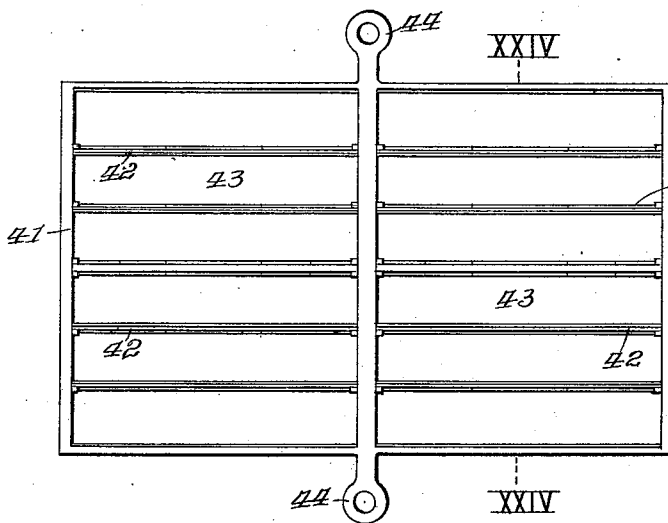
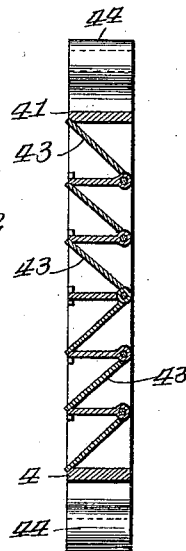

FIG. 24.



WITNESSES:

*Herbert Bradley*  
*J. C. Gaither*

INVENTOR,

*Samuel Diescher*  
by *Samuel S. Wolcott*

Att'y.

S. DIESCHER.

APPARATUS FOR PICKLING OR CLEANING METAL SHEETS.

(Application filed July 26, 1899.)

(No Model.)

14 Sheets—Sheet 14.

FIG. 25.

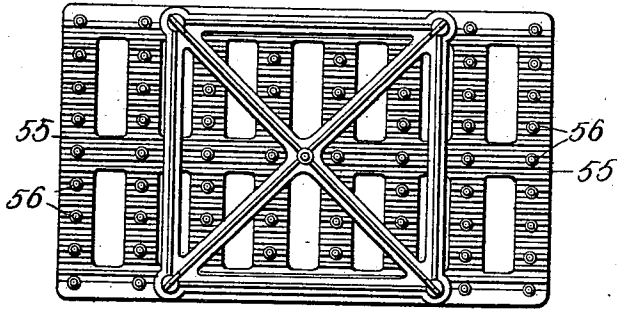

FIG. 26.

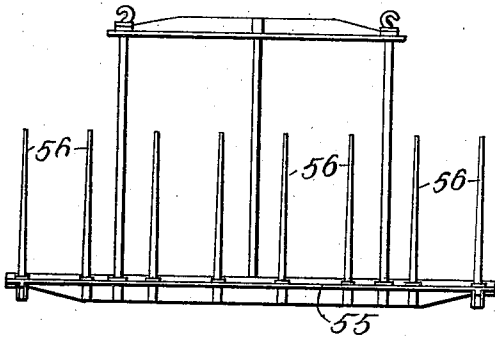

FIG. 27.

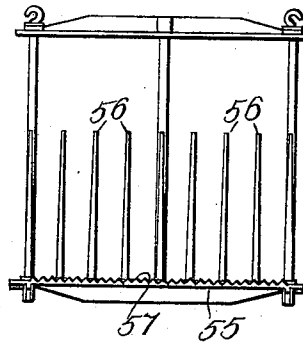

FIG. 29.

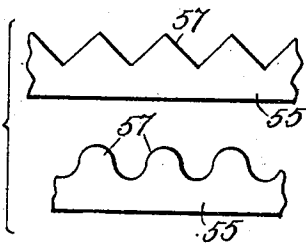
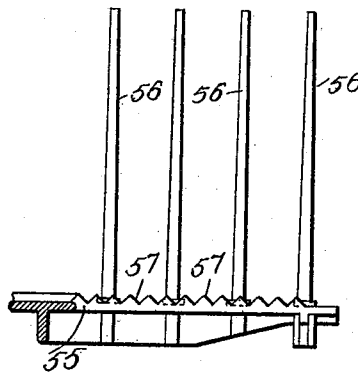

FIG. 28.



WITNESSES:

*Herbert Bradley*  
*J. C. Gaither*

INVENTOR,

*Samuel Diescher*  
 by *Darius S. Wolcott*  
 Att'y.

# UNITED STATES PATENT OFFICE.

SAMUEL DIESCHER, OF PITTSBURG, PENNSYLVANIA.

## APPARATUS FOR PICKLING OR CLEANING METAL SHEETS.

SPECIFICATION forming part of Letters Patent No. 646,266, dated March 27, 1900.

Application filed July 26, 1899. Serial No. 725,131. (No model.)

*To all whom it may concern:*

Be it known that I, SAMUEL DIESCHER, a citizen of the United States, residing at Pittsburg, in the county of Allegheny and State of Pennsylvania, have invented or discovered a certain new and useful Improvement in Apparatus for Pickling or Cleaning Metal Sheets, of which improvement the following is a specification.

The invention described herein relates to certain improvements in mechanism for pickling and swilling metal sheets, and has for one object a construction of mechanism whereby the cage containing the sheets to be cleaned can be easily and quickly shifted into position above the bath, lowered into and raised from the bath, and then shifted to a convenient point for unloading and recharging the cage.

It is a further object of the invention to effect such a movement of the liquid in the bath as will insure a uniform and practically simultaneous cleansing of all portions of the sheets in the bath and also to effect a separation of the sheets, so that the liquid will have access to all parts thereof.

The invention is hereinafter more fully described and claimed.

In the accompanying drawings, forming a part of this specification, Figure 1 is a top plan view of my improved machine. Fig. 2 is a side elevation of the same. Figs. 3 and 4 are sectional elevations of the same, the planes of section being indicated, respectively, by the lines III III and IV IV, Fig. 1. Fig. 5 is a top plan view of a modified construction of the machine. Fig. 6 is a side elevation of the same. Figs. 7 and 8 are sectional elevations, the planes of section being indicated, respectively, by the lines VII VII and VIII VIII, Fig. 5. Fig. 9 is a sectional elevation of the cleaning-tank and plunger, illustrating a further modification of said parts. Fig. 10 is a sectional plan of the tank proper, the plane of section being indicated by the line X X, Fig. 9. Figs. 11 and 12 are sectional elevations illustrating further modifications in the construction of the tank and plunger. Fig. 13 is a sectional plan, the plane of section being indicated by the line XIII XIII, Fig. 12. Figs. 14 and 15 are detail ele-

ventions on an enlarged scale, showing a portion of the movable track-section and trolley-lock. Figs. 16 to 19, inclusive, are detail views, on an enlarged scale, of the clutch and friction connections from the driving-shaft to the hoisting-shaft. Figs. 20, 21, and 22 are details of the plunger-operating devices. Fig. 23 is a plan view of the plunger. Fig. 24 is a section of the same, the plane of section being indicated by the line XXIV XXIV, Fig. 23. Figs. 25, 26, and 27 are plans and elevations of the crate. Fig. 28 is an enlarged detail view of the same. Fig. 29 illustrates different forms of spreading-teeth for the crate, and Fig. 30 is a sectional detail view of the frictional connection between the driving and hoisting shafts.

In the practice of my invention I employ a continuous elevated track 1, from which the crates carrying the sheets to be treated are suspended. This track, which is suspended from transverse beams 2, supported by a suitable framework, consists of two angle-bars secured on opposite sides of the suspending-straps 3. This track, which may be circular, oval, or of other suitable shape, is so arranged with reference to the treating tanks or vats 4 as to pass directly over said tanks or vats. A portion 1<sup>a</sup> of the track above the tanks or vats is made vertically movable, and the angle-bars forming this movable section are secured to the plates 5, which are provided with guide portions or arms 6, arranged between the angle-bars of the stationary portion of the track, as clearly shown in Figs. 1, 2, 3, 7, 8, 14, and 15. These arms will guide the movable track during its up and down movements and insure its being brought into alinement with the stationary portion of the track when raised. The movable section is supported by chains 7, having one end attached to the plates 5, said chains passing over the guide-pulleys 8 and the sprocket-wheels 9 and having their opposite ends connected to counterweights 10. The sprocket-wheels 9 are keyed on a shaft 11, which is frictionally driven by suitable mechanism interposed between it and the driving-shaft 12. A desirable form of such connection is clearly shown in Figs. 16 to 19, inclusive, and consists of a wheel 13, keyed to the shaft 11 and

provided with an outwardly-turned flange 14, which is preferably thickened or enlarged, as shown in Fig. 18. A gear-wheel 15 is loosely mounted on the shaft 11 and is provided with an angular rib 16, adapted to bear against one side and extend over the flange 14 of the wheel 13. The flange 14 is clamped against the angular rib 16 by an annular plate 17, which is drawn against the flange by bolts 18. The gear-wheel 13 intermeshes with a pinion 19, loosely mounted on the power-shaft 12, with which it is adapted to be locked by a clutch 20. One part or member of this clutch is so keyed to the shaft as to rotate therewith and also to be moved longitudinally thereof by the lever 21 into and out of engagement with the other member of the clutch.

In order to hold the rail-section 1<sup>a</sup> and the load carried thereby in raised position after the pinion 19 has been freed by the disengagement of the parts or members of the clutch 20, provision is made for locking the hoisting-shaft 11 as against rotation. A convenient means for locking the shaft consists in forming a notched rib 22 on the wheel 13 for engagement with a tooth 23 on the weighted lever 24, which is pivotally mounted on a stand 25, secured to the frame of the machine. The notch in the rib 22 is so located that the tooth of lever 24 will engage therewith when the movable rail-section has been raised up into alinement with the track.

The outwardly-projecting flanges of the angle-bars forming the continuous track form supports or rails for the wheels 26 of the trolleys, said wheels being loosely mounted on pins or studs 27, secured to an inverted yoke 28, said yoke spanning the entire track, as shown clearly in Figs. 14 and 15. This construction will permit of the free travel of the trolley around the track without interference by the guide-arm 6 and straps 3. A cross-bar 29 is pivotally connected to the yoke and is provided with eyes 30, whereby the supporting-chains of the crate may be connected to the yoke. By this construction it is possible to shift the crates to any position along the track, thereby rendering it possible to load some crates while other crates are being treated in the baths, and then to raise the movable track-section into alinement with the main track and shift the crates, with treated sheets, along to a point where they can be unloaded and another load of sheets placed thereon.

In order to hold the trolleys or trucks from movement off the movable rail-section when it is loaded, catches or dogs 31 are pivotally mounted on the plates 5 of the movable sections in such position that notches in their forward ends will engage projections 32 on the trucks or trolleys, as clearly shown in Figs. 14 and 15. As shown, these catches or dogs 31 are provided with upwardly-extending arms 33, which are so weighted and project at such an angle or direction from the dogs that the weights will tend to hold the

dogs in either locked or unlocked position, the weights being shifted across the axis of movement as the dogs are changed from locked to unlocked position. It will be observed by reference to Figs. 2, 7, and 14 that the tailpieces of the dogs project in reverse direction to the normal movement of the trolleys as they are shifted—*i. e.*, from right to left in Figs. 2 and 7—along the track, so that when the trolleys are pushed into position on the movable track-section the tails of the dogs will be raised by contact with the trolley during such movement, thereby shifting the weighted arms over in position to yieldingly hold the dogs so as to engage the projections 32. In order to effect an automatic unlocking of the trolleys when the rail-section 1<sup>a</sup> is raised into alinement with the main track, levers 34 are loosely mounted on the pivot-pins of the dogs and are made of such a length as to project beyond the tailpiece thereof, which is provided with a lateral projection 35, on which the levers will rest. As the movable rail-section is raised these levers 35 will strike stops 36 on the frame of the machine, and thereby on the continued upward movement of the rail-section shift the dogs 31 into unlocked position, so that the trolleys can be shifted along the track. As the rail-section is lowered the ends of these levers 34 will strike the stops 36, which will raise the levers without in any way affecting the dogs 31.

As shown in Figs. 1, 3, and 4, the crate or frame carrying the sheets to be treated is lowered into the tank or vat 4 and is preferably supported while the sheets are being treated by stops or shoulders 40, although the crate or frame may be supported by the removable rail-section. After the crate or frame has been lowered, so that the sheets are wholly immersed in the cleansing liquid, the latter is given a vertical movement between the sheets by the operation of a suitably-arranged plunger, as will be hereinafter described.

It has heretofore been customary in pickling apparatus to arrange the sheet-supporting crate in one compartment of the tank and a plunger in the other compartment, said compartments communicating with each other by ports or passages near the bottoms thereof. The agitation of the fluid was effected by up-and-down movement of the plunger, which being solid and nearly filling the compartment in which it was placed would merely effect a back-and-forth movement of the fluid in both compartments. In such a construction a considerable power is necessarily lost in overcoming the inertia of the fluid and also in changing its direction of movement. In order to overcome this objectionable feature, I employ plungers which are provided with openings therethrough, and in said openings are arranged any suitable form or construction of valves which are adapted to be opened as the plunger is moved in one direc-

tion and to be automatically closed by the weight of fluid when the direction of movement of the plunger is reversed. A desirable construction of such a form of plunger is clearly shown in Figs. 3, 8, 9, 23, and 24 and consists of a frame 41, having a series of longitudinal plates 42 secured therein, said plates dividing the frame into longitudinal compartments. In each of these compartments is arranged a leaf 43, pivotally mounted at its lower edge and of a sufficient width to extend diagonally across this compartment. In such a construction these valves or leaves will when the plunger is moved down swing up into approximate parallelism with the longitudinal plates, and thereby permit a free flow of water through the compartment. When the direction of movement of the plunger is reversed, the valves will be thrown across their openings or compartments onto adjacent partitions, thereby rendering the plunger approximately solid, so that the fluid will be caused to move with the plunger.

As shown in Figs. 3, 23, and 24, the frame 41 is provided with lugs 44, which project laterally through slots in partitions 39 and are connected to the lower ends of rods 45, which have their upper ends connected to levers 46. These levers are secured on shafts 47, which are loosely mounted in bearings 48, secured on the frame of the machine. The opposite ends of the levers are longitudinally slotted or grooved for the reception of blocks 49, loosely mounted therein and carried by pins 50, eccentrically secured to the disks 51. These disks are secured on shafts 52, having gear-wheels 53 keyed thereon. These gear-wheels are driven directly or through an interposed idler by a pinion 54 on the power-shaft 12, as clearly shown in Figs. 1 and 2. By reference to Figs. 20 and 21 it will be seen that when the disks 51 are rotated in the direction of the arrow *a* the block 49 will move toward the axes of the levers and that therefore the movements of the levers will be accelerated during the upward movement of the blocks, but will be retarded as the blocks move down, as they will be shifted away from the axes of the levers. By this construction and arrangement quick down and slow up movements of the plungers are effected.

As shown in Figs. 25 to 28, inclusive, the crate for the metal sheets consists of a bed-plate 55, having openings therethrough to permit of the free flow of liquid to the sheets, said openings being by preference at an angle to the planes of the sheets when placed in the plate. The sheets are supported in a vertical position by posts 56. In order to insure the separation of the lower edges of the sheets, so that the pickling and cleaning fluid may flow freely between, ribs or projections 57 are formed on the upper face of the plate 55. When the sheets are placed in the crate, they should be arranged with the lower edges of adjoining sheets on opposite sides of the ribs or projections. As the liq-

uid is forced up along the sides of the sheets the latter will be lifted up, and as they drop down they will strike on the ribs or projections in such manner as to effect a separation of adhering sheets.

While it is preferred to use two vats or a double vat, as shown in Figs. 1 to 7, inclusive, and to make the removable rail-section 1<sup>a</sup> of sufficient length to extend over both chambers or vats, so that two batches of sheets can be simultaneously treated, it will be readily understood by those skilled in the art that the capacity of the machine can be easily increased or diminished.

In order to cause the cleansing fluid to flow vertically between the sheets, it is preferred to arrange the plunger so as to operate in a space or chamber below the frame or crate, as shown in Figs. 3, 4, and 11, and to avoid using tanks of excessive depths means are provided, as by the passages 4<sup>a</sup>, whereby the liquid raised by the upward movement of the plungers can flow from a point or points above the upper edges of the sheets to a point or points adjacent to the lower end of the tank or vat. By the employment of a valved plunger of the character described the vertical flow of liquid up between the sheets will be always in the same direction, thereby rendering it possible to use less power for reciprocating the plunger. While such movement is preferably effected by arranging the plunger directly below the crate, as shown in Figs. 1 to 4, it may be effected by arranging the plunger in one or more of the conduits or passages 4<sup>a</sup>, which are connected to the tank or vat at or adjacent to its upper and lower ends, as shown in Figs. 5 to 10, inclusive. In the construction shown in Figs. 5 to 8 the plunger is shown in a passage or conduit connected to the treating-tank by ports 38 through the partition 39. In this form of apparatus it is preferred to arrange the hoisting mechanism and the plunger-operating mechanism alongside of the tank or vat. In order to operate the hoisting-shaft 11, carrying the sprocket-wheels 9, a drum 58 is secured on the shaft 11, and one end of a chain 59 is secured to the drum. The opposite end of the chain is attached to a drum 60, which is frictionally secured to the shaft 61, as shown in Fig. 30. As shown, disks 62 are keyed to the shaft 61 and are drawn against opposite sides of a rib 14<sup>a</sup>, formed on the interior wall of the drum by means of bolts 18<sup>a</sup>. The shaft 61 is driven by a gear-wheel 15<sup>a</sup>, keyed on the shaft and intermeshing with a pinion 19<sup>a</sup>, detachably secured on the power-shaft 12<sup>a</sup> by any suitable form of clutch mechanism, (indicated at 20<sup>a</sup>.)

As shown in Fig. 8, the bottoms of the passage 4<sup>a</sup> are preferably shaped to direct the liquid into the main compartment, the bottom of which is shaped to direct the liquid up through the crate. In order to prevent the formation of a current up along the partition

adjacent to the chamber containing the plunger, a deflecting-plate 63 is secured to the partition, as shown.

As shown in Figs. 9 and 10, a plunger for effecting the circulation of the liquid may be placed in passages or conduits 4<sup>a</sup> on each side of the tank or vat.

While it is preferred to employ a valved plunger to effect a continuous circulation of the liquid, the invention, as regards the claims covering the mechanism for handling the crates and for operating the plungers, is not limited to use in connection with valved plungers, as solid plungers can be used with such devices. When using solid plungers, it is preferred either to use one plunger, arranged in the tank or vat below the crate, as shown in Fig. 11, or a plunger in each of the passages or conduits 4<sup>a</sup>, as shown in Figs. 12 and 13.

I claim herein as my invention—

1. In an apparatus for pickling or cleaning sheets, the combination of an elevated track having a movable section, a trolley movable along the track, a lock carried by the track and arranged to engage the trolley as it moves to position on the section, a vat or tank arranged below the movable track-section, means for raising and lowering the track-section, and means actuated on the upward movement of the track-section to release the trolley-lock, substantially as set forth.

2. In an apparatus for pickling or cleaning sheets, the combination of an elevated track having a movable section, a winding-drum having a frictional connection to the driving-shaft, a stop for holding the drum as against rotation, a chain connecting the drum to the movable track-section, a trolley movable along the track and a vat or tank arranged below the movable track-section, substantially as set forth.

3. In an apparatus for pickling or cleaning sheets, the combination of a vat or tank, a frame for supporting the sheets to be treated, a plunger arranged below the frame, and means for reciprocating the plunger, whereby

vertical currents are produced in the cleansing liquid between the sheets in the tank or vat, substantially as set forth.

4. In an apparatus for pickling or cleaning sheets, the combination of a tank or vat, a frame for supporting the sheets to be treated, and a reciprocating plunger operative on the cleansing fluid provided with valves or leaves arranged to be operated by fluid-pressure on the movement of the plunger, substantially as set forth.

5. In an apparatus for pickling or cleaning sheets, the combination of a tank or vat, passages connected to the upper and lower ends of the tank or vat, a frame for supporting the sheets to be treated in the tank or vat between its upper and lower ends, and a reciprocating plunger operative on the cleansing liquid for causing an upward movement of the liquid in the tank or vat, substantially as set forth.

6. In an apparatus for pickling or cleaning sheets, the combination of a tank or vat, passages connected to the upper and lower ends of the tank or vat, a frame for supporting the sheets to be treated in the tank or vat between its upper and lower ends, a valved plunger operative on the cleansing liquid and means for reciprocating the plunger, substantially as set forth.

7. In an apparatus for pickling or cleaning sheets, the combination of a tank or vat, a plunger for effecting a movement of the liquid in the tank or vat said plunger being provided with valves arranged to be operated by fluid-pressure on the movement of the plunger, and mechanism interposed between the power-shaft and the plunger whereby the latter is given a quick forward and a slow return movement while the shaft rotates at a uniform speed, substantially as set forth.

In testimony whereof I have hereunto set my hand.

SAMUEL DIESCHER.

Witnesses:

DARWIN S. WOLCOTT,  
F. E. GAITHER.