



US00D780834S

(12) **United States Design Patent**
Eberlen

(10) **Patent No.:** **US D780,834 S**

(45) **Date of Patent:** **** Mar. 7, 2017**

(54) **SET OF STRING ATTACHMENTS FOR GUITAR**

(71) Applicant: **Richard Michael Eberlen**,
Waxahachie, TX (US)

(72) Inventor: **Richard Michael Eberlen**,
Waxahachie, TX (US)

(**) Term: **15 Years**

(21) Appl. No.: **29/505,407**

(22) Filed: **Oct. 15, 2015**

(51) **LOC (10) Cl.** **17-03**

(52) **U.S. Cl.**
USPC **D17/20**

(58) **Field of Classification Search**
USPC D17/4, 18-20, 99; D25/119, 199
(Continued)

(56) **References Cited**

U.S. PATENT DOCUMENTS

3,962,948 A * 6/1976 Marletta G10D 3/04
84/294
4,248,126 A * 2/1981 Lieber G10D 3/04
84/299

(Continued)

OTHER PUBLICATIONS

Musikmesse 2012 video: AddString—fit an extra string to your acoustic guitar, posted at musicradar.com, earliest date available Mar. 23, 2012, [online], acquired on Jul. 1, 2016. Available from Internet, <URL: <http://www.musicradar.com/news/guitars/musikmesse-2012-video-addstring-fit-an-extra-string-to-your-acoustic-guitar-536054>>.*

(Continued)

Primary Examiner — Cathron Brooks

Assistant Examiner — Aula Soroush

(57) **CLAIM**

I claim the ornamental design for a set of string attachments for guitar, as shown.

DESCRIPTION

FIG. 1 is a front perspective view of a set of string attachments for guitar showing my new design, mounted on a guitar which is shown in broken lines for illustrative purposes only and forming no part of the claimed design; FIG. 2 is a front perspective view of the top element in FIG. 1 thereof; FIG. 3 is a front perspective view of the middle element in FIG. 1 thereof; FIG. 4 is a front perspective view of the bottom element in FIG. 1 thereof; FIG. 5 is a front view of the top element in FIG. 1 thereof; FIG. 6 is a back side view of the top element in FIG. 1 thereof; FIG. 7 is a left side view of the top element of FIG. 1 thereof; FIG. 8 is a right side view of the top element in FIG. 1 thereof; FIG. 9 is a top view of the top element in FIG. 1 thereof; FIG. 10 is a bottom view of the top element in FIG. 1 thereof; FIG. 11 is a front view of the middle element of FIG. 1 thereof; FIG. 12 is a back side view of the middle element in FIG. 1 thereof; FIG. 13 is a left side view of the middle element in FIG. 1 thereof; FIG. 14 is a right side view of the middle element in FIG. 1 thereof; FIG. 15 is a top view of the middle element in FIG. 1 thereof; FIG. 16 is a bottom view of the middle element in FIG. 1 thereof; FIG. 17 is a front view of the bottom element in FIG. 1 thereof; FIG. 18 is a back side view of the bottom element in FIG. 1 thereof; FIG. 19 is a left side view of the bottom element in FIG. 1 thereof;

(Continued)

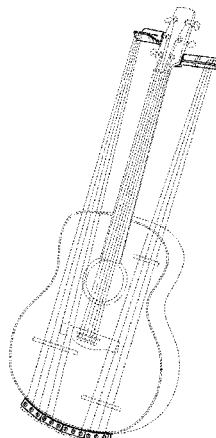

FIG. 20 is a right side view of the bottom element in FIG. 1 thereof;
 FIG. 21 is a top view of the bottom element in FIG. 1 thereof;
 FIG. 22 is a bottom view of the bottom element in FIG. 1 thereof;
 FIG. 23 is a front view of the bottom element in FIG. 1 thereof;
 FIG. 24 is a front perspective view of a set of string attachments for guitar in use;
 FIG. 25 is a front perspective view of a set of string attachments for guitar in use; and,
 FIG. 26 is a front perspective view of a set of string attachments for guitar in use.
 The guitar and other elements shown in broken lines in FIG. 1, FIG. 23, FIG. 24, FIG. 25 and FIG. 26 form no part of the claimed design and are included merely to indicate or to illustrate the environment of the design.

1 Claim, 9 Drawing Sheets

(58) **Field of Classification Search**
 CPC G10H 1/342; G10H 3/18; G10H 2220/076;

G10H 2220/165; G10H 2220/221; G10H 2220/30; G10H 2220/485
 See application file for complete search history.

(56) **References Cited**

U.S. PATENT DOCUMENTS

D705,043	S *	5/2014	Michaud	D8/366
D733,934	S *	7/2015	Underkofler	D25/102
2014/0083275	A1 *	3/2014	Martin	G10D 3/12
				84/307
2015/0310838	A1 *	10/2015	Borisoff	G10D 3/14
				84/299
2016/0104467	A1 *	4/2016	Chang	G10D 3/14
				84/304

OTHER PUBLICATIONS

Ben Morris Modifies His Martin Guitar for Tripleplay, posted at tripletalk.fishman.com, earliest date available Nov. 27, 2013, [online], acquired on Jul. 1, 2016. Available from Internet, <URL: <http://tripletalk.fishman.com/2013/11/ben-morris-modifies-his-martin-guitar-for-tripleplay/>>.*

* cited by examiner

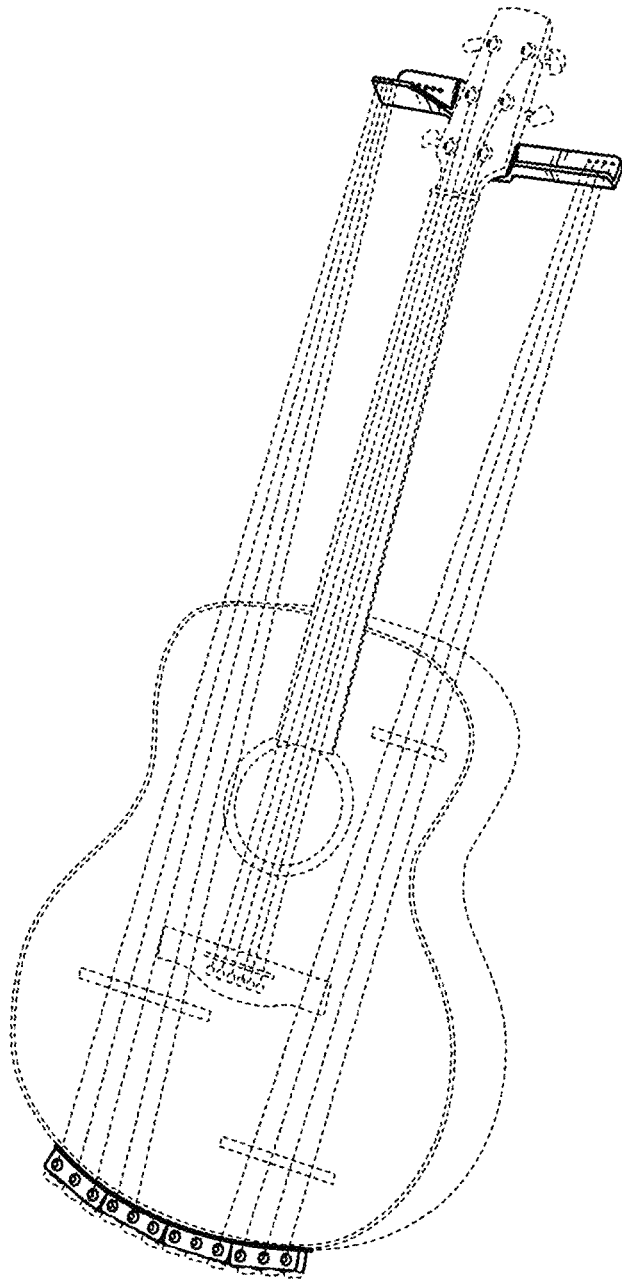

FIG. 1

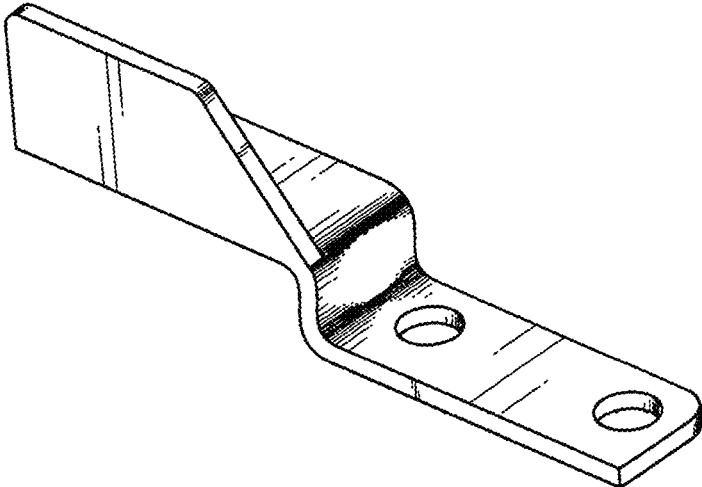

FIG. 2

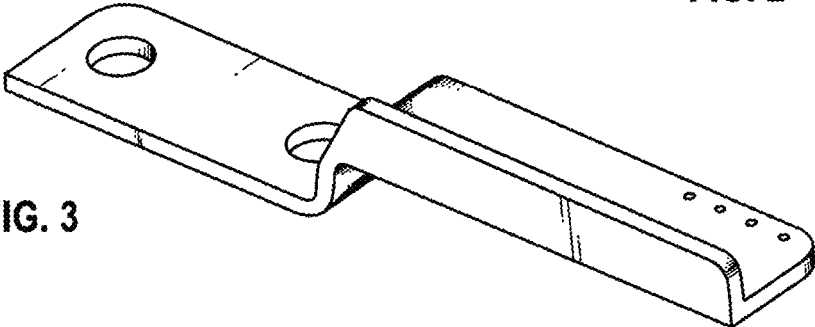

FIG. 3

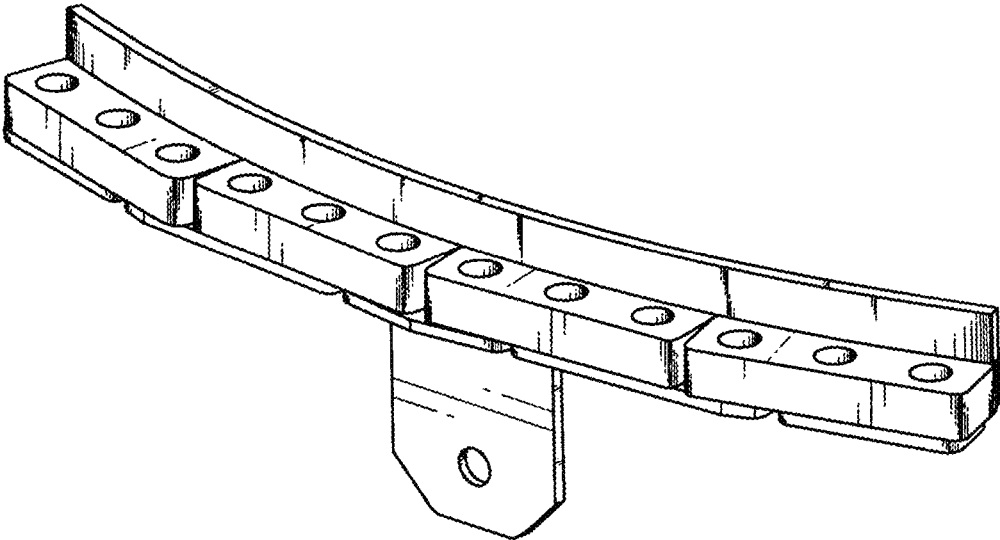

FIG. 4



FIG. 5

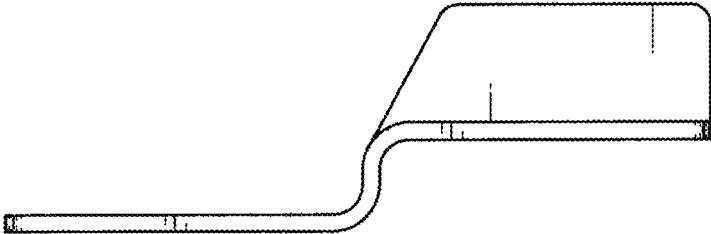

FIG. 6

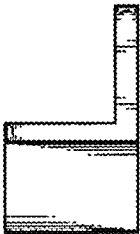

FIG. 7

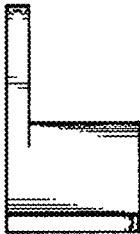

FIG. 8



FIG. 9



FIG. 10

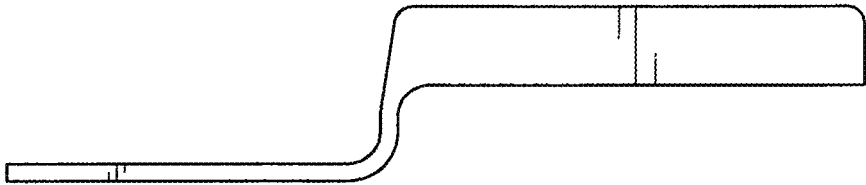

FIG. 11

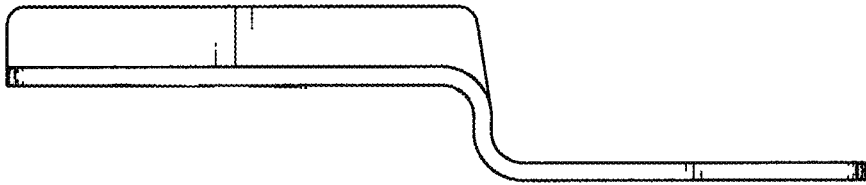

FIG. 12



FIG. 13

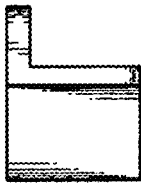

FIG. 14

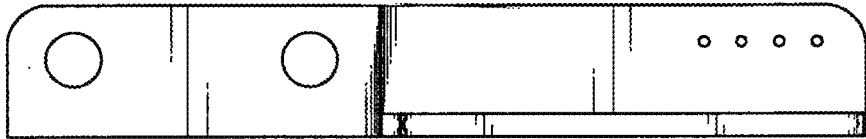

FIG. 15



FIG. 16

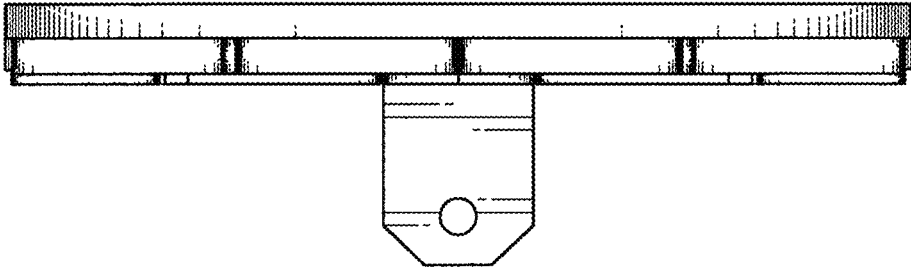

FIG. 17

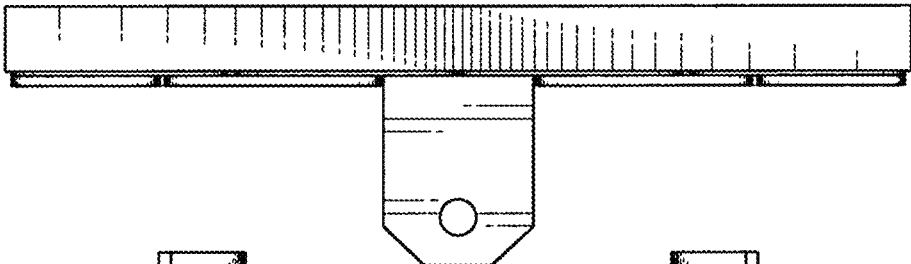

FIG. 18

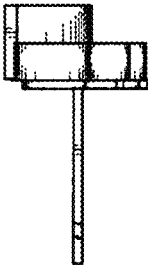

FIG. 19

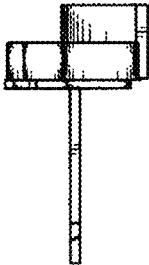

FIG. 20

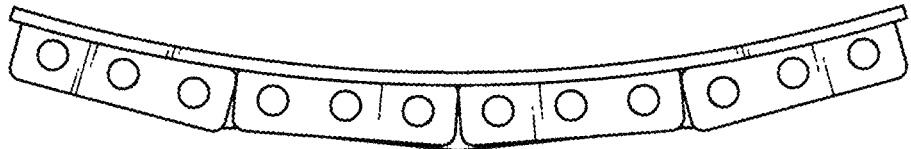

FIG. 21

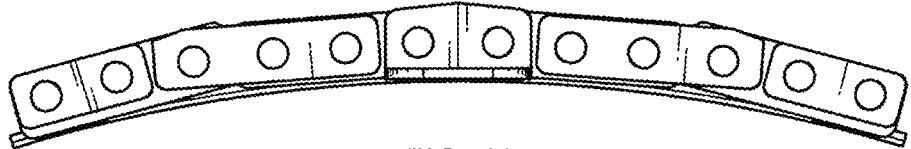

FIG. 22

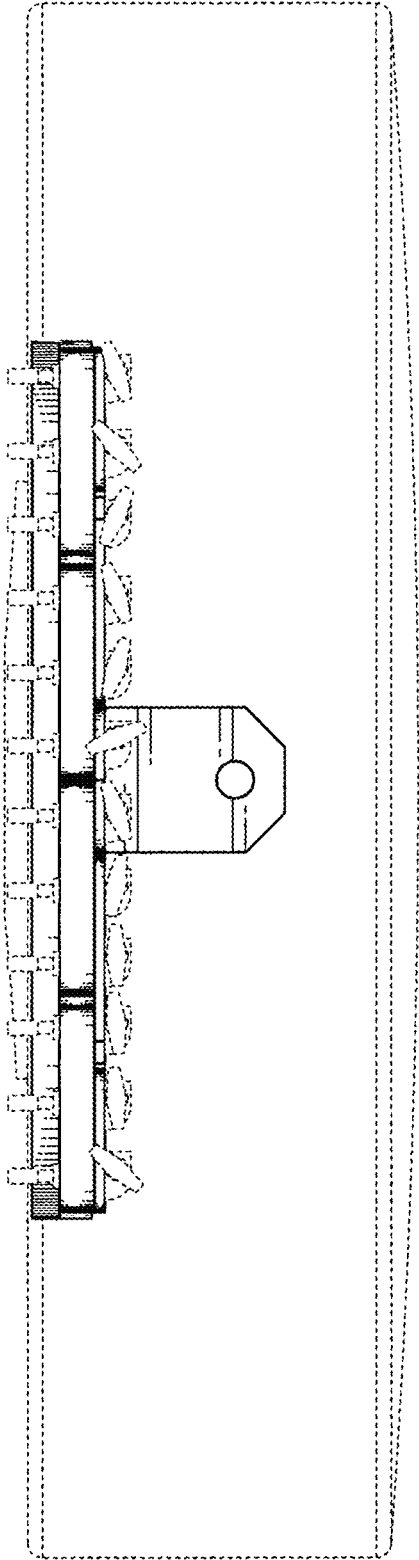

FIG. 23

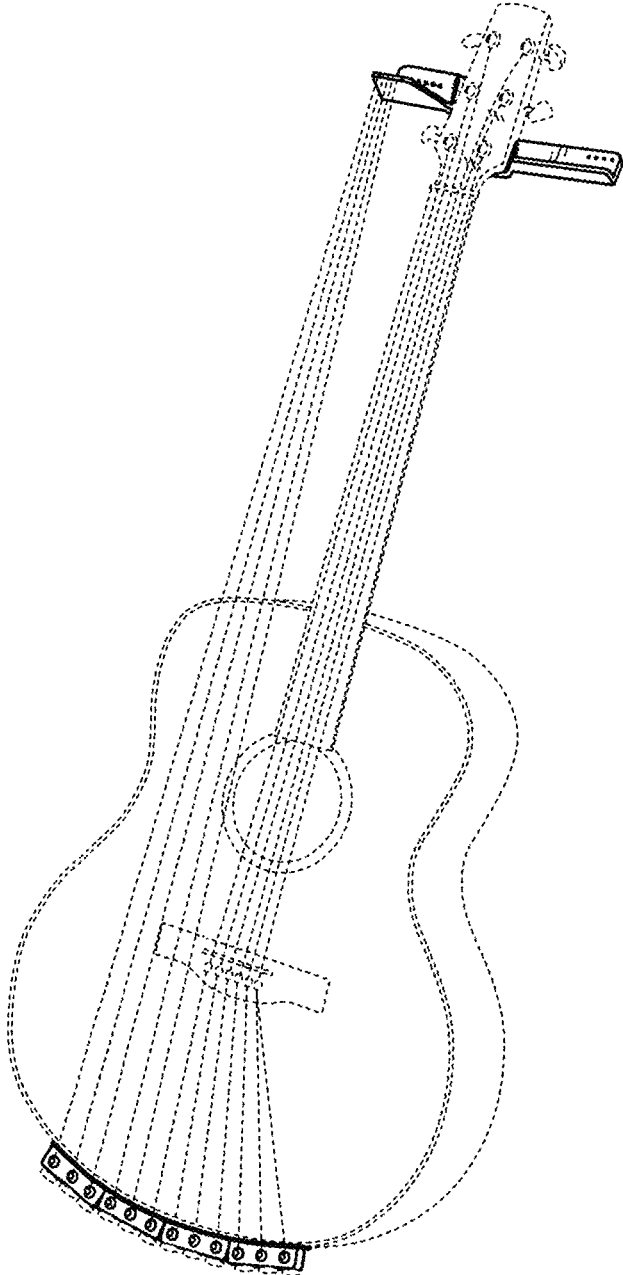

FIG. 24

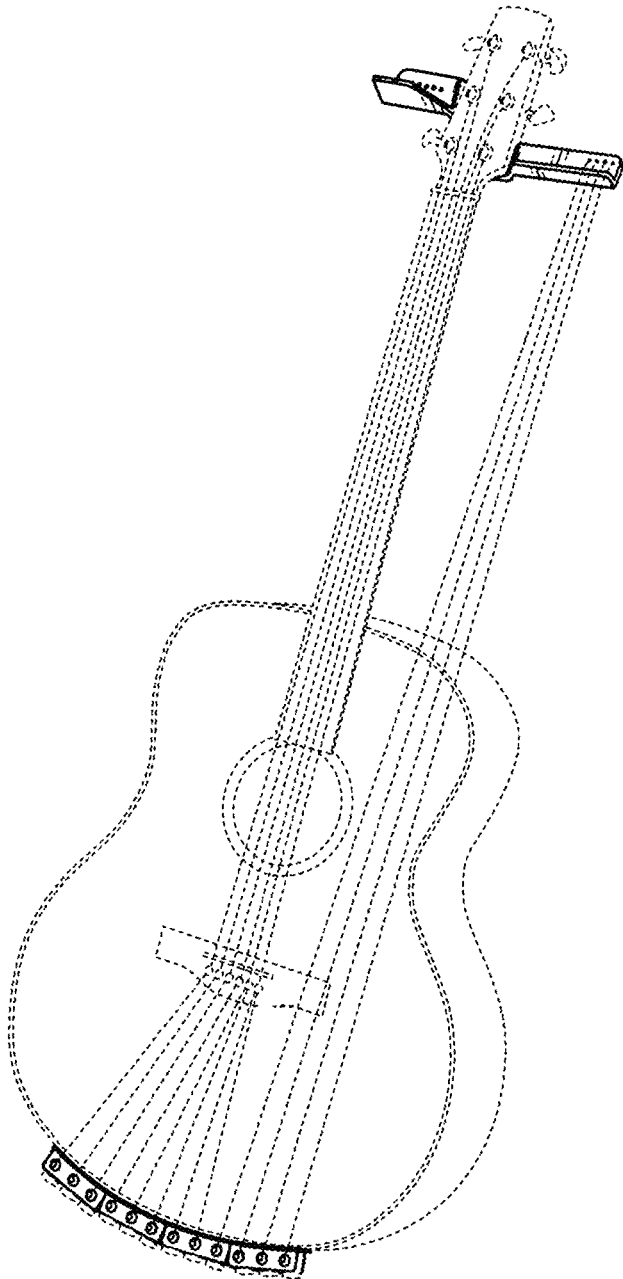

FIG. 25

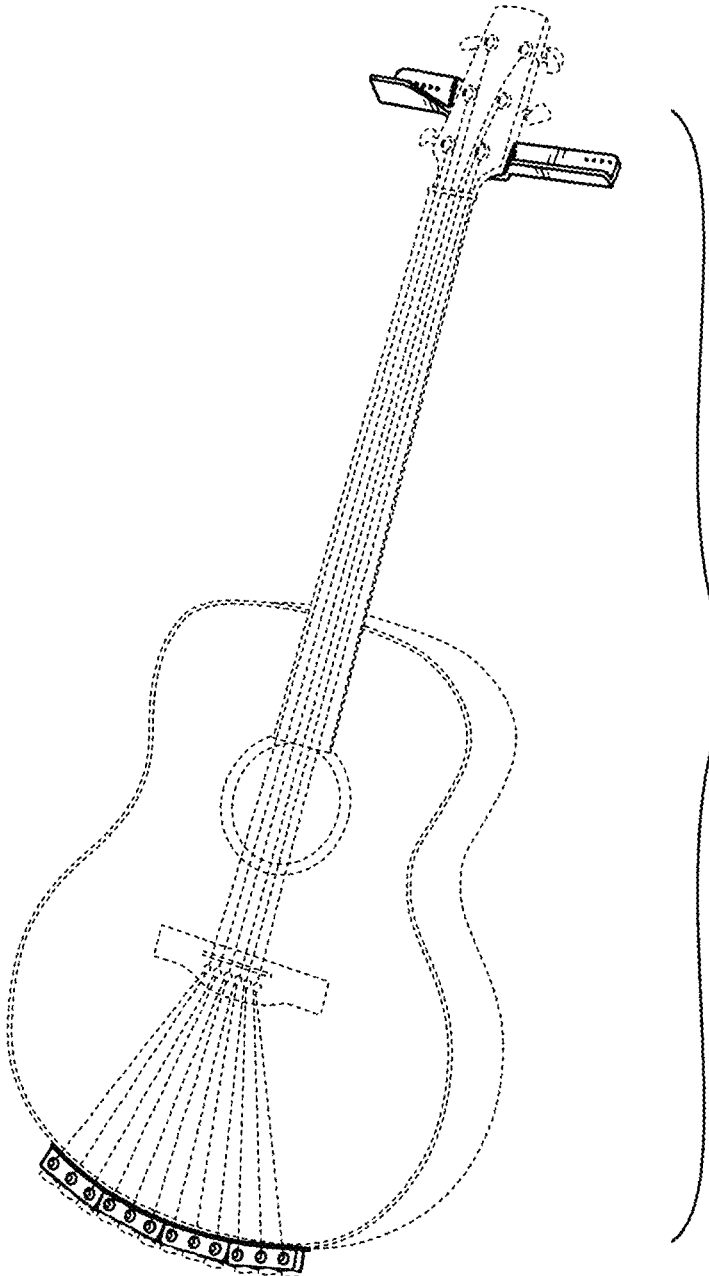

FIG. 26