

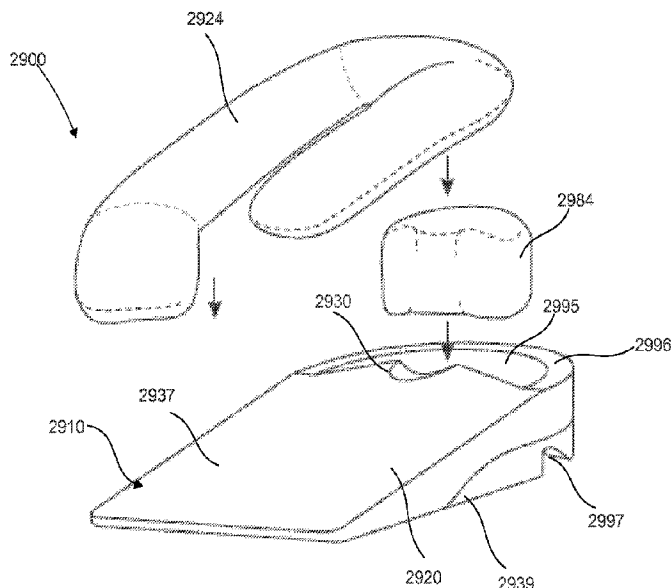

(86) **Date de dépôt PCT/PCT Filing Date:** 2015/08/07
 (87) **Date publication PCT/PCT Publication Date:** 2016/02/11
 (45) **Date de délivrance/Issue Date:** 2023/10/17
 (85) **Entrée phase nationale/National Entry:** 2017/02/03
 (86) **N° demande PCT/PCT Application No.:** US 2015/044151
 (87) **N° publication PCT/PCT Publication No.:** 2016/022886
 (30) **Priorité/Priority:** 2014/08/08 (US14/455,389)

(51) **Cl.Int./Int.Cl. A47G 9/10** (2006.01),
A47C 20/00 (2006.01), **A47C 3/16** (2006.01),
A47G 9/06 (2006.01), **A61G 7/075** (2006.01)
 (72) **Inventeurs/Inventors:**
 MELCHER, CARL, US;
 CLARK, AARON, US;
 ERICKSON, CLINT, US
 (73) **Propriétaire/Owner:**
 AMENITY HEALTH, INC., US
 (74) **Agent:** SMART & BIGGAR LP

(54) **Titre : SYSTEMES ET PROCEDES DE COUSSIN THERAPEUTIQUE**
 (54) **Title: THERAPEUTIC CUSHION SYSTEMS AND METHODS**



(57) **Abrégé/Abstract:**

Apparatus and methods for providing therapeutic treatment for symptoms associated with GERD and/or other digestive disorders and/or other medical conditions are described herein. In some embodiments, an apparatus includes a base support having a support element portion and an encasement portion. The support element portion has a first end portion, a second end portion and a top surface disposed at an angle relative to a bottom surface. The second end portion has a height greater than the first end portion. A support pillow member is fixedly coupled to the base support between at least a portion of the encasement portion and at least a portion of the second end portion of the support element portion. The support pillow member, the support element portion and the encasement portion collectively define an interior region that includes a receiving portion configured to receive at least a portion of a user's arm therein.

(12) INTERNATIONAL APPLICATION PUBLISHED UNDER THE PATENT COOPERATION TREATY (PCT)

(19) World Intellectual Property
Organization
International Bureau(10) International Publication Number
WO 2016/022886 A3(43) International Publication Date
11 February 2016 (11.02.2016)

(51) International Patent Classification:

A47C 20/02 (2006.01) A47G 9/10 (2006.01)
A47C 20/04 (2006.01)

(21) International Application Number:

PCT/US2015/044151

(22) International Filing Date:

7 August 2015 (07.08.2015)

(25) Filing Language:

English

(26) Publication Language:

English

(30) Priority Data:

14/455,389 8 August 2014 (08.08.2014) US

(63) Related by continuation (CON) or continuation-in-part (CIP) to earlier application:

US 14/455,389 (CIP)
Filed on 8 August 2014 (08.08.2014)(71) Applicant: AMENITY HEALTH, INC. [US/US]; 8830
Rehco Rd., Suite E, San Diego, California 92121 (US).(72) Inventors: MELCHER, Carl; 5851 Camino De La Costa,
La Jolla, California 92037 (US). CLARK, Aaron; 11366
West San Raphael Driveway, San Diego, California 92130
(US). ERICKSON, Clint; 6317 Peach Way, San Diego,
California 92130 (US).(74) Agents: ZIMMER, Kevin, J. et al.; Cooley LLP, 1299
Pennsylvania Ave., Suite 700, Washington, District of
Columbia 20004 (US).(81) Designated States (unless otherwise indicated, for every
kind of national protection available): AE, AG, AL, AM,
AO, AT, AU, AZ, BA, BB, BG, BH, BN, BR, BW, BY,
BZ, CA, CH, CL, CN, CO, CR, CU, CZ, DE, DK, DM,
DO, DZ, EC, EE, EG, ES, FI, GB, GD, GE, GH, GM, GT,
HN, HR, HU, ID, IL, IN, IR, IS, JP, KE, KG, KN, KP, KR,
KZ, LA, LC, LK, LR, LS, LU, LY, MA, MD, ME, MG,
MK, MN, MW, MX, MY, MZ, NA, NG, NI, NO, NZ, OM,
PA, PE, PG, PH, PL, PT, QA, RO, RS, RU, RW, SA, SC,
SD, SE, SG, SK, SL, SM, ST, SV, SY, TH, TJ, TM, TN,
TR, TT, TZ, UA, UG, US, UZ, VC, VN, ZA, ZM, ZW.(84) Designated States (unless otherwise indicated, for every
kind of regional protection available): ARIPO (BW, GH,
GM, KE, LR, LS, MW, MZ, NA, RW, SD, SL, ST, SZ,
TZ, UG, ZM, ZW), Eurasian (AM, AZ, BY, KG, KZ, RU,
TJ, TM), European (AL, AT, BE, BG, CH, CY, CZ, DE,
DK, EE, ES, FI, FR, GB, GR, HR, HU, IE, IS, IT, LT, LU,
LV, MC, MK, MT, NL, NO, PL, PT, RO, RS, SE, SI, SK,
SM, TR), OAPI (BF, BJ, CF, CG, CI, CM, GA, GN, GQ,
GW, KM, ML, MR, NE, SN, TD, TG).

Declarations under Rule 4.17:

— as to applicant's entitlement to apply for and be granted a
patent (Rule 4.17(ii))

Published:

— with international search report (Art. 21(3))

— before the expiration of the time limit for amending the
claims and to be republished in the event of receipt of
amendments (Rule 48.2(h))

[Continued on next page]

(54) Title: THERAPEUTIC CUSHION SYSTEMS AND METHODS

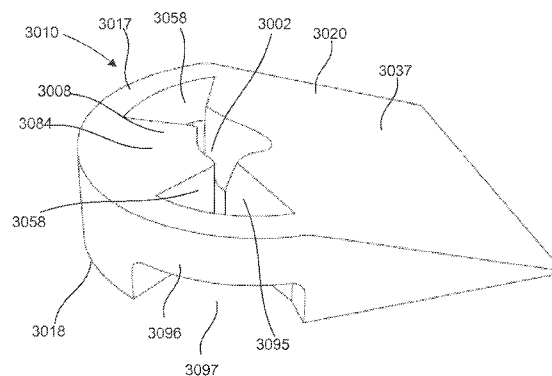

FIG. 102

(57) Abstract: Apparatus and methods for providing therapeutic treatment for symptoms associated with GERD and/or other digestive disorders and/or other medical conditions are described herein. In some embodiments, an apparatus includes a base support having a support element portion and an encasement portion. The support element portion has a first end portion, a second end portion and a top surface disposed at an angle relative to a bottom surface. The second end portion has a height greater than the first end portion. A support pillow member is fixedly coupled to the base support between at least a portion of the encasement portion and at least a portion of the second end portion of the support element portion. The support pillow member, the support element portion and the encasement portion collectively define an interior region that includes a receiving portion configured to receive at least a portion of a user's arm therein.

WO 2016/022886 A3 

(88) Date of publication of the international search report:
7 April 2016

THERAPEUTIC CUSHION SYSTEMS AND METHODS

[1001]

Background

[1002] Some embodiments described herein relate to therapeutic cushion systems and methods, and in particular, to therapeutic cushion systems and methods for use in the treatment of various medical conditions, such as, for example, gastro-esophageal reflux disease.

[1003] Gastro-esophageal reflux disease (GERD) is a medical term that describes a malady in which acid-laden, partially digested stomach contents reflux – i.e., flow in an abnormal backward fashion – from the stomach into the esophagus. Reflux of gastric contents into the esophagus is most common, and does the most damage, when the GERD sufferer is sleeping and unaware that the reflux is occurring.

[1004] Some known systems use pillows or other supportive apparatuses to effectively manage or control symptoms of conditions that otherwise would have required a medical prescription or surgery to alleviate. For example, some known pillow options include an elevated pillow with a protrusion within the pillow focused on the cervical region of the neck, which is intended to provide comfort or better resting conditions for individuals suffering from cardiac conditions, emphysema or other respiratory difficulties. Such a

pillow does not allow for an extended support below the sacrum region of the spine; nor does the pillow provide for any comfortable position other than supine.

[1005] Some known devices include an orthopedic pillow that can be used to minimize snoring in an individual. While such a pillow can be used to address conditions such as snoring, such a pillow may not be configured to treat conditions such as GERD. In fact, such an orthopedic pillow typically only provides an elevation component and fails to address any other component that may be desired for the relief of symptoms of a GERD sufferer.

[1006] Another known system includes a support pillow including a body with a central section and two wings for use in controlling symptoms associated with head and neck hyperextension, which is often seen in infants with bronchopulmonary dysplasia, or other related conditions. Another known system includes an apparatus that can be used to prevent positional plagiocephaly in an infant by distributing loads otherwise borne by the head of the infant across a horizontal surface. While these systems may provide a benefit to infants, their specific design and structural engineering is based on the user of the pillow being an infant. Such pillows are not disclosed as providing a benefit for an adult or adolescent user suffering from GERD.

[1007] Most of the above described known systems focus on conditions relating to infants and/or the head-only region, without regard to addressing support of, or interaction with, the entire body. Other known systems include a pillow meant to accommodate an adult person (as a general body pillow) or an infant (to assist in supporting the infant in a seated position). Such systems, however, do not contemplate use of the pillow to alleviate symptoms relating to gastric or esophageal disorders. Additionally, such a pillow may not accommodate the necessary features specific for controlling or managing such disorders. Another known system includes a large, contoured body pillow to facilitate relief from persistent back and neck pain, respiratory and digestive disorders; however, the bulk of such a pillow is typically in excess of what is practical for use by a normal individual in a bed.

[1008] Thus, a need exists for therapeutic cushion systems and methods that can address the shortcomings of the known pillow systems identified above, and that can be used to manage and/or control symptoms associated with GERD and/or other medical conditions, while maintaining a practical, accommodating fit for the user.

Summary

[1009] Apparatus and methods for providing therapeutic treatment for symptoms associated with GERD and/or other digestive disorders and/or other medical conditions are described herein. In some embodiments, an apparatus includes a base support that includes a support element portion and an encasement portion. The support element portion has a first end portion and a second end portion and a top surface disposed at an angle relative to a bottom surface of the support element. The second end portion has a height greater than the first end portion. A support pillow member is fixedly coupled to the base support between at least a portion of the encasement portion and at least a portion the second end portion of the support element portion. The support pillow member, the support element portion and the encasement portion collectively defining an interior region, the interior region including a receiving portion configured to receive at least a portion of a user's arm therein.

[1009a] In particular, there is described an apparatus comprising: a base support including a support element portion and an encasement portion, the support element portion having a first end portion and a second end portion and a top surface disposed at an angle relative to a bottom surface, the second end portion of the support element portion having a height greater than a height of the first end portion of the support element portion, the second end portion of the support element portion and the encasement portion collectively defining an interior region bounded entirely about a perimeter of the interior region by a portion of the encasement portion and a portion of the second end portion of the support element portion; and a support pillow member disposable within the interior region, the support pillow member, the second end portion of the support element portion and the encasement portion collectively defining a first receiving portion between the support pillow member and at least one of the second end portion of the support element portion or the encasement portion and a second receiving portion, opposite the first receiving portion, between the support pillow member and at least one of the second end portion of the support element portion or the encasement portion when the support pillow member is disposed within the interior region, the first receiving portion and the second receiving portion each configured to receive at least a portion of a user's arm therein.

[1009b] There is also described an apparatus comprising: a base support including a support element portion and an encasement portion, the support element portion having a first end portion and a second end portion and a top surface disposed at an angle relative to a bottom surface, the second end portion of the support element portion having a height greater than a height of the first end portion of the support element portion, the support element portion having a centerline extending between the first end portion and the second end portion, the encasement portion extending from the second end portion of the support element portion, the support element portion and the encasement portion collectively defining an interior region bounded entirely about a perimeter of the interior region by a portion of the encasement portion and a portion of the second end portion of the support element portion; and a support pillow member disposable within the interior region, the support pillow member, the support element portion and the encasement portion collectively defining a receiving portion configured to receive at least a portion of a user's arm therein when the support pillow member is disposed within the interior region, the receiving portion having a centerline laterally offset from the centerline of the support element portion.

[1009c] There is also described an apparatus comprising: a base support including a support element portion and an encasement portion, the support element portion having a first end portion and a second end portion and a top surface disposed at an angle relative to a bottom surface, the second end portion having a height greater than a height of the first end portion, the support element portion and the encasement portion collectively defining an interior region between the support element portion and the encasement portion; and a support pillow member disposable within the interior region, the support pillow member includes a first side wall and an opposite second side wall, the support pillow member, the support element portion and the encasement portion collectively defining a first receiving portion and a second receiving portion each configured to receive at least a portion of a user's arm therein when the support pillow member is disposed within the interior region, the first receiving portion being disposed between the encasement portion and one of the first side wall and the second side wall of the support pillow member, the second receiving portion being disposed between the other of the first side wall and the second side wall of the support pillow member.

[1009d] There is also described an apparatus, comprising: a base support including a support element portion and an encasement portion, the support element portion having a first end portion and a second end portion and a top surface disposed at an angle relative to a bottom surface, the second end portion of the support element portion having a height greater than a height of the first end portion of the support element portion; and a support pillow member fixedly coupled to the base support between at least a portion of the encasement portion and at least a portion the second end portion of the support element portion, the support pillow member having a first wall disposed at a first angle relative to a longitudinal centerline of the base support and a second wall on an opposite side of the support pillow member disposed at a second angle relative to the longitudinal centerline, the second wall angled in an opposite direction of the first wall, the support pillow member, the support element portion and the encasement portion collectively defining an interior region, the interior region including a receiving portion configured to receive at least a portion of a user's arm therein.

[1009e] There is also described an apparatus comprising: a base support including a support element portion and an encasement portion, the support element portion having a first end portion and a second end portion and a top surface disposed at an angle relative to a bottom surface, the second end portion of the support element portion having a height greater than a height of the first end portion of the support element portion, the second end portion of the support element portion and the encasement portion collectively defining a bounded interior region; and a support pillow member disposable within the interior region, the support pillow member, the second end portion of the support element portion and the encasement portion collectively defining a receiving portion between the support pillow member and at least one of the second end portion of the support element portion or the encasement portion when the support pillow member is disposed within the interior region, the receiving portion having a bounded perimeter having a smaller volume than the interior region and configured to receive at least a portion of a user's arm therein.

[1009f] There is also described an apparatus comprising: a base support including a support element portion and an encasement portion, the support element portion having a first end portion and a second end portion and a top surface disposed at an angle relative to a bottom

surface, the second end portion of the support element portion having a height greater than a height of the first end portion of the support element portion, the support element portion having a centerline extending between the first end portion and the second end portion, the support element portion and the encasement portion collectively defining a bounded interior region; and a support pillow member disposable within the interior region, the support pillow member, the support element portion and the encasement portion collectively defining a receiving portion configured to receive at least a portion of a user's arm therein when the support pillow member is disposed within the interior region, the receiving portion having a bounded perimeter having a centerline laterally offset from the centerline of the support element portion.

[1009g] There is also described an apparatus comprising: a base support including a support element portion and an encasement portion, the support element portion having a first end portion and a second end portion and a top surface disposed at an angle relative to a bottom surface, the second end portion having a height greater than a height of the first end portion, the support element portion and the encasement portion collectively defining an interior region between the support element portion and the encasement portion; and a support pillow member disposable within the interior region, the support pillow member, the support element portion and the encasement portion collectively defining a first receiving portion and a second receiving portion each configured to receive at least a portion of a user's arm therein when the support pillow member is disposed within the interior region, the first receiving portion being disposed on an opposite side of the support pillow member than the second receiving portion.

[1009h] There is also described an apparatus for providing therapeutic treatment, comprising: a support element portion having a first end portion and a second end portion and a top surface disposed at an angle relative to a bottom surface, the second end portion having a height greater than a height of the first end portion; an encasement portion disposed proximate to the second end portion of the support element portion, the second end portion of the support element having an end surface facing the encasement portion, the end surface of the support element extending from a center portion of the support element toward a lateral side of the apparatus and being angled in a direction away from the encasement portion in a

top view of the apparatus, the support element portion and the encasement portion collectively defining an interior region bounded entirely about a perimeter of the interior region by a portion of the encasement portion and a portion of the support element portion; and a support pillow member disposable within the interior region, the support pillow member, the second end portion of the support element portion and the encasement portion collectively defining a receiving portion between the support pillow member and at least one of the second end portion of the support element portion or the encasement portion, the receiving portion configured to receive at least a portion of a user's arm therein.

Brief Description of the Drawings

[1010] FIG. 1 is a schematic illustration of a therapeutic cushion system, according to an embodiment.

[1011] FIG. 2 is a perspective view of a therapeutic cushion system, according to an embodiment.

[1012] FIG. 3 is a side view of the therapeutic cushion system of FIG. 2.

[1013] FIG. 4 is top view of the riser element and support element of the therapeutic cushion system of FIG. 2.

[1014] FIG. 5 is a top view of the body element of the therapeutic cushion system of FIG. 2.

[1015] FIG. 6 is a side perspective view of the riser element and support element of the therapeutic cushion system of FIG. 2.

[1016] FIG. 7 is a side view of the support element of the therapeutic cushion system of FIG. 2.

[1017] FIG. 8 is a front perspective view of the support element of the therapeutic cushion system of FIG. 2.

[1018] FIG. 9 is a side perspective view of the cushion member of the support element of FIG. 8.

[1019] FIG. 10 is a front perspective view of the riser element of the therapeutic cushion system of FIG. 2.

[1020] FIG. 11 is a partially unassembled view of the riser element of FIG. 10.

[1021] FIG. 12 is a side view of the riser element of FIG. 11.

[1022] FIG. 13 is a top view of the body element of the therapeutic cushion system of FIG. 2.

[1023] FIGS. 14A and 14B illustrate a method of assembling the therapeutic cushion system of FIG. 2.

[1024] FIGS. 15A-15C illustrate a method of adjusting a position of the riser element relative to the support element of the therapeutic cushion system of FIG. 2.

[1025] FIGS. 16-19 illustrate a method of using the therapeutic cushion system of FIG. 2.

[1026] FIGS. 20 and 21 are each a perspective view of the therapeutic cushion system of FIG. 2 illustrating the body element in different configurations.

[1027] FIGS. 22 and 23 are each a perspective view of the therapeutic cushion system of FIG. 2 illustrating an alternative orientation for use of the therapeutic cushion system.

[1028] FIGS. 24(A)-(J) each illustrate the therapeutic cushion system of FIG. 2 in use by a user with the body element in different configurations and the user in different positions.

[1029] FIG. 25 is a perspective view of a therapeutic cushion system, according to another embodiment.

[1030] FIGS. 26-29 and 30(A) – 30(I) each illustrate a different embodiment of a body element.

[1031] FIGS. 31(A) – 31(E) each illustrate a different embodiment of a body element including different filler zoning options.

[1032] FIG. 32(A) is a top view of a therapeutic cushion system, according to another embodiment shown in a first configuration, and FIG. 32(B) is a top view of the therapeutic cushion system of FIG. 32(A) shown in a second configuration.

[1033] FIG. 33 is a side view of the therapeutic cushion system of FIGS. 32(A) and 32(B).

[1034] FIG. 34 is a perspective view of the therapeutic cushion system of FIG. 32(A) and 32(B) shown on a bed, and FIG. 35 is a perspective view of the therapeutic cushion system of FIGS. 32(A) and 32(B) illustrating a user positioned on the therapeutic cushion system.

[1035] FIG. 36 is a perspective view of a therapeutic cushion system, according to another embodiment with an optional pillow.

[1036] FIG. 37 is a side view of the therapeutic cushion system of FIG. 36, and FIG. 38 is an end view taken along line A-A in FIG. 37.

[1037] FIG. 39 is a top view of the therapeutic cushion system of FIG. 37 with a side support member shown on two sides of the support element.

[1038] FIG. 40 is a cross-sectional view of the side support member of the therapeutic cushion system of FIG. 36.

[1039] FIG. 41 is a top view of the therapeutic cushion system of FIG. 36 with an optional body element.

[1040] FIGS. 42(A)-(D) each illustrate a cross-sectional view of alternative embodiments of a side support member.

[1041] FIG. 43 is a perspective view of a therapeutic cushion system, according to another embodiment with an optional pillow.

[1042] FIG. 44 is a side view of the therapeutic cushion system of FIG. 43, and FIG. 45 is an end view taken along line B-B in FIG. 44.

[1043] FIG. 46 is a top view of the therapeutic cushion system of FIG. 43 with a side support member shown disposed on two sides of the support element.

[1044] FIG. 47 is a top view of the therapeutic cushion system of FIG. 43 with an optional body element.

[1045] FIG. 48 is a side view of a therapeutic cushion system, according to another embodiment, and FIG. 49 is an end view of the therapeutic cushion system of FIG. 61 taken along line C-C in FIG. 48.

[1046] FIG. 50 is a top view of a sling member of the therapeutic cushion system of FIG. 48 and FIG. 51 is a top view of a sling member of the therapeutic cushion system of FIG. 48 with an optional body element.

[1047] FIG. 52 is a top view of the frame and pad member of the therapeutic cushion system of FIG. 48.

[1048] FIG. 53 is a side view of the therapeutic cushion system of FIG. 48 illustrating a bed length version, and FIG. 54 is a side view of the therapeutic cushion system of FIG. 48 illustrating a torso length version.

[1049] FIG. 55 is a side view of a therapeutic cushion system, according to another embodiment.

[1050] FIG. 56 is a side view of a therapeutic cushion system, according to another embodiment.

[1051] FIG. 57 is a side view of a therapeutic cushion system, according to another embodiment, and FIG. 58 is a side exploded view of the therapeutic cushion system of FIG. 57.

[1052] FIG. 59 is a side view of a therapeutic cushion system, according to another embodiment, and FIG. 60 is a side exploded view of the therapeutic cushion system of FIG. 59.

[1053] FIG. 61 is a top view of a support element, according to an embodiment.

[1054] FIG. 62 is a side view of the support element of FIG. 61, shown adjacent a portion of a riser element.

[1055] FIG. 63 is a front end view of the support element of FIG. 61 taken along line E-E in FIG. 61, and FIG. 64 is a foot end view of the support element of FIG. 61 taken along line D-D in FIG. 61.

[1056] FIG. 65 is a side view of a support element, according to another embodiment.

[1057] FIG. 66 is a side view of a support element, according to another embodiment.

[1058] FIG. 67 is a perspective view of a therapeutic cushion system, according to another embodiment.

[1059] FIG. 68 is a top view of the therapeutic cushion system of FIG. 67.

[1060] FIG. 69 is an end view of the therapeutic cushion system of FIG. 67 taken along line F-F in FIG. 68.

[1061] FIG. 70 is a side view of the therapeutic cushion system of FIG. 67.

[1062] FIG. 71 is a perspective view of a therapeutic cushion system, according to another embodiment.

[1063] FIG. 72 is a top view of the therapeutic cushion system of FIG. 71.

[1064] FIG. 73 is an end view of the therapeutic cushion system of FIG. 71 taken along line G-G in FIG. 72.

[1065] FIG. 74 is a side view of the therapeutic cushion system of FIG. 71.

[1066] FIG. 75 is a top view of a therapeutic cushion system according to another embodiment.

[1067] FIG. 76 is a top view of a support element including non-slip features, according to an embodiment.

[1068] FIG. 77 is a side perspective view of a support element including non-slip features according to another embodiment.

[1069] FIGS. 78(A)-78(F) are each a top view of a different embodiment of a support element including non-slip features.

[1070] FIG. 79 is a side perspective view of a therapeutic cushion system, according to another embodiment.

[1071] FIG. 80 is a side perspective view of a side extension element of the therapeutic cushion system of FIG. 79.

[1072] FIG. 81 is a perspective view of a therapeutic cushion system, according to another embodiment.

[1073] FIG. 82 is a side view of the therapeutic cushion system of FIG. 81.

[1074] FIG. 83 is a top view of the therapeutic cushion system of FIG. 81.

[1075] FIG. 84 is a bottom view of the therapeutic cushion system of FIG. 81.

[1076] FIG. 85 is a front end view and FIG. 86 is a rear end view of the therapeutic cushion system of FIG. 81.

[1077] FIG. 87 is a side view of the therapeutic cushion system of FIG 81 with the body element removed.

[1078] FIG. 88 is a front end view and FIG. 89 is a rear end view of the therapeutic cushion system of FIG. 81 with the body element removed.

[1079] FIG. 90 is a top view and FIG. 91 is a bottom view of the therapeutic cushion system of FIG. 81 with the body element removed.

[1080] FIG. 92 is a perspective view of a portion of a base support of the therapeutic cushion system of FIG. 81 shown transparent to illustrate an interior region of the base support.

[1081] FIG. 93 is a top view of a portion of the therapeutic cushion system of FIG. 81 with the body element removed.

[1082] FIG. 94 is an exploded view of the therapeutic cushion system of FIG. 81.

- [1083] FIG. 95 is a partial exploded view of the therapeutic cushion system of FIG. 81.
- [1084] FIG. 96 is a perspective view of a therapeutic cushion system, according to another embodiment.
- [1085] FIG. 97 is a top view of the therapeutic cushion system of FIG. 96.
- [1086] FIG. 98 is a side view of the therapeutic cushion system of FIG. 96.
- [1087] FIG. 99 is a bottom view of the therapeutic cushion system of FIG. 96.
- [1088] FIG. 100 is a front end view of the therapeutic cushion system of FIG. 96.
- [1089] FIG. 101 is a rear end view of the therapeutic cushion system of FIG. 96.
- [1090] FIG. 102 is a front perspective view of the base support of the therapeutic cushion system of FIG. 96.
- [1091] FIG. 103 is a bottom perspective view of the base support of the therapeutic cushion system of FIG. 96.
- [1092] FIG. 104 is a rear end view of the base support of the therapeutic cushion system of FIG. 96.
- [1093] FIG. 105 is a side view of the base support of the therapeutic cushion system of FIG. 96.
- [1094] FIG. 106 is a top view of the base support of the therapeutic cushion system of FIG. 96.
- [1095] FIG. 107 is a bottom view of the base support of the therapeutic cushion system of FIG. 96.
- [1096] FIG. 108 is a rear perspective view of the base support of therapeutic cushion system of FIG. 96.
- [1097] FIG. 109 is a top view of the body element of the therapeutic cushion system of FIG. 96.

- [1098] FIG. 110 is a front end view of the body element of the therapeutic cushion system of FIG. 96.
- [1099] FIG. 111 is a side view of the body element of the therapeutic cushion system of FIG. 96.
- [1100] FIG. 112 is a partial side view illustrating a user disposed on the therapeutic cushion system of FIG. 96.
- [1101] FIG. 113 is a perspective view illustrating a user disposed on the therapeutic cushion system of FIG. 96.
- [1102] FIG. 114 is a top view of a body element, according to another embodiment.
- [1103] FIG. 115 is a front end view of the body element of FIG. 114.
- [1104] FIG. 116 is a side view of the body element of FIG. 114.
- [1105] FIG. 117 is a side view of the body element of FIG. 114.
- [1106] FIG. 118 is a top view of a body element, according to another embodiment.
- [1107] FIG. 119 is a front end view of the body element of FIG. 118.
- [1108] FIG. 120 is a side view of the body element of FIG. 118.
- [1109] FIG. 121 is an exploded perspective view of the base support of FIG. 102 and the body element of FIG. 114, shown with the base support disposed on a support surface.
- [1110] FIG. 122 is a perspective view of the base support of FIG. 102 and the body element of FIG. 114, shown with the base support disposed on a support surface.
- [1111] FIG. 123 is a side view illustrating a user disposed on the base support of FIG. 102 and using the body element of FIG. 114.
- [1112] FIGS. 124 and 125 are each a bar graph illustrating results of a first example study evaluating the effects of using a therapeutic cushion system.
- [1113] FIGS. 126-129 are each a bar graph illustrating results of a second example study evaluating the effects of using a therapeutic cushion system.

Detailed Description

[1114] Apparatus and methods for providing therapeutic treatment for symptoms associated with GERD and/or other digestive disorders and/or other medical conditions or ailments are described herein. In some embodiments, a therapeutic cushion system as described herein can allow the user to sleep comfortably for an extended period of time in a substantially flat or an inclined right-side lateral decubitus (RLD) position, or a substantially flat or an inclined left-side lateral decubitus (LLD) position. In the inclined RLD position or the inclined LLD position, the therapeutic cushion system can serve to minimize, or eliminate, gastro-esophageal reflux. For example, the inclined RLD position can facilitate the emptying of the stomach into the duodenum, and the inclined LLD position can facilitate the reduction of reflux episodes.

[1115] In some embodiments, an apparatus includes a base support that includes a support element portion and an encasement portion. The support element portion has a first end portion and a second end portion and a top surface disposed at an angle relative to a bottom surface of the support element. The second end portion has a height greater than the first end portion. A support pillow member is fixedly coupled to the base support between at least a portion of the encasement portion and at least a portion the second end portion of the support element portion. The support pillow member, the support element portion and the encasement portion collectively defining an interior region, the interior region including a receiving portion configured to receive at least a portion of a user's arm therein.

[1116] In some embodiments, an apparatus includes a base support including a support element portion and an encasement portion. The support element portion has a first end portion and a second end portion and a top surface disposed at an angle relative to a bottom surface. The second end portion of the support element portion has a height greater than a height of the first end portion of the support element portion. A support pillow member formed with a foam material is coupled to the encasement portion. The support pillow member, the support element portion and the encasement portion collectively define an interior region that includes a receiving portion configured to receive at least a portion of a user's arm therein.

[1117] In some embodiments, an apparatus includes a body element that includes a foam insert member disposed within an outer cover. The body element includes an arc portion,

and a first arm and a second arm each extending from the arc portion. The body element further includes a side support bolster disposed on at least one of the first arm or the second arm and configured to maintain a user in a side position. In some embodiments, the body element includes a neck support portion that can support a user's neck when the user's head is disposed on the arc portion.

[1118] In some embodiments, an apparatus includes a support base and a support pillow member. The support base includes a support element portion and an encasement portion. The support element portion has a first end portion and a second end portion and a top surface disposed at an angle relative to a bottom surface of the support element. The second end portion has a height greater than the first end portion. The support element portion and the riser element portion collectively define an interior region. The support pillow member is disposable within the interior region. The support pillow member, the support element portion and the encasement portion collectively define a receiving portion configured to receive at least a portion of a user's arm therein.

[1119] In some embodiments, a method of using a therapeutic cushion system can include coupling a riser element of a cushion system to a support element of the cushion system such that the riser element and the support element collectively define a receiving portion between the riser element and the support element. The support element includes a top surface disposed at an angle relative to a bottom surface. A body element can be provided for placement on at least one of a portion of the support element or a portion of the riser element. The body element has a first arm and a second arm connected by an arc portion. The support element, riser element and body element are collectively configured to support a user in an inclined side position with the user's arm disposable within the receiving portion.

[1120] In some embodiments, an apparatus includes a support element having a first end portion, a second end portion and a top surface disposed at an angle relative to a bottom surface. The second end portion has a height greater than a height of the first end portion. A riser element is coupled to a body element such that the body element can be moved between a first position in which a first portion of the body element extends from a side portion of the riser element and a second portion of the body element is disposed substantially perpendicular to the first portion, and a second position in which the first portion of the body element is disposed on top of the riser element. The second portion of

the body element configured to be disposed at least partially on the support portion when the riser element is disposed adjacent the second end portion of the body element.

[1121] In some embodiments, a method of treating symptoms associated with gastro-esophageal reflux disease (GERD) can include positioning a user's body on a therapeutic cushion system such that the user is disposed on the therapeutic cushion system in an inclined right-side lateral decubitus (RLD) position or inclined left-side lateral decubitus (LLD) position such that the user's pyloric sphincter is disposed at an elevation lower than an elevation of the user's esophageal sphincter. For example, the user can be disposed on a support element (or a base support as described herein) of a therapeutic cushion system having an inclined top surface of between 6 degrees and 30 degrees. In such an embodiment, the user can be positioned on the support element (or base support) at an angle between about 5 and 20 degrees depending on factors, such as, for example, the density and/or deflection properties of the support element, and/or the weight of the user. The user's right arm or left arm can be positioned within a receiving portion of the therapeutic cushion system defined between the support element and a riser element of the therapeutic cushion system. The user of the therapeutic cushion system can be maintained in the inclined RLD position or LLD position for a sufficient time period to treat symptoms associated with GERD. In some embodiments, the time period is at least one hour. In some embodiments, the time period is 6 hours. In some embodiments, the maintaining includes positioning a body element of the therapeutic cushion system proximate at least one of the riser element or the support element of the therapeutic cushion system. In some embodiments, the maintaining includes positioning a body element of the therapeutic cushion system proximate a base support of the therapeutic cushion system

[1122] In some embodiments, an apparatus includes a cushion system including a support element portion and a riser element portion. The support element portion has a first end portion and a second end portion and a top surface disposed at an angle relative to a bottom surface. The second end portion has a height greater than a height of the first end portion. The support element portion and the riser element portion collectively define a receiving portion configured to receive a user's arm therein and a side support member is configured to be disposed on a portion of the top surface of the support element portion. The side support member is configured to maintain the user in a side position on the cushion system.

[1123] In some embodiments, an apparatus includes a frame member and a sling member coupled to the frame member. The sling member defines an opening between a first portion and a second portion of the sling member. The first portion of the sling member is configured to support a user's head and the second portion of the sling member is disposed at an angle between about 6 and about 30 degrees relative to the first portion. The opening is configured to receive at least a portion of the user's arm therethrough. A pad member is disposed below the opening and configured to support at least a portion of the user's arm when disposed through the opening. The apparatus is configured to be supported on a support surface and support a user in an inclined side position.

[1124] In some embodiments, an apparatus includes a body element that has a first end portion including an arc portion, and a first arm and a second arm each extending away from the arc portion. The body element is configured to maintain a user in a side position. The body element includes an outer sleeve member and a pillow insert. The outer sleeve member includes stitching along an outer edge portion and is free of stitching along an inner edge portion.

[1125] In some embodiments, an apparatus includes a support element that includes a first end portion and a second end portion that has a height greater than a height of the first end portion. The support element also includes a top surface disposed at an angle relative to a bottom surface, a cushion portion, and an inflatable chamber configured to adjustably modify a firmness and/or height of the support element. The apparatus further includes a riser element. The riser element and the support element collectively define a receiving portion configured to receive a user's arm.

[1126] In some embodiments, a kit includes a cushion system that includes multiple support elements and multiple riser elements. Each support element from the multiple support elements includes a first end portion and a second end portion and a top surface disposed at an angle relative to a bottom surface. Each support element from the multiple support elements is selectively stackable on top of another of the support elements to vary at least one of a thickness or a firmness of a support portion of the cushion system. Each riser element from the multiple riser elements is selectively stackable on top of another riser element to vary at least one of a thickness or a firmness of a riser portion of the cushion system. The riser portion and the support portion are collectively configured to support a

user in an inclined side position with an arm of the user disposed within a receiving portion defined between the support portion and the riser portion.

[1127] In some embodiments, a kit includes a cushion system that includes multiple stackable elements. Each stackable element from the multiple stackable elements includes a support element and a riser element. Each support element includes a first end portion and a second end portion and a top surface disposed at an angle relative to a bottom surface. At least one stackable element from the multiple stackable elements includes an opening defined between the support element and the riser element. Each stackable element from the multiple stackable elements is selectively stackable on top of another stackable element to vary at least one of a thickness or a firmness of cushion system.

[1128] In some embodiments, an apparatus includes a support element and a riser element. The support element has a first end portion and a second end portion and a top surface disposed at an angle relative to a bottom surface. The second end portion has a height greater than a height of the first end portion. The top surface is disposed at an angle between about 6 degrees and about 30 degrees relative to the bottom surface. The riser element includes straps configured to adjustably couple the riser element proximate to the second end portion of the support element.

[1129] FIG. 1 is a schematic illustration of a therapeutic cushion system according to an embodiment. A therapeutic cushion system (also referred to herein as “cushion system”) 100 includes a support element 120 (also referred to herein as “wedge support” or “wedge element”), a riser element 122 and a body element 124 (also referred to herein as a “body pillow”). As described above, the cushion system 100 can be used, for example, for the treatment of symptoms associated with GERD and/or other digestive disorders and/or other medical conditions. For example, the cushion system 100 can allow the user to sleep for an extended period of time in an inclined right-side lateral decubitus (RLD) position (as described in more detail below), which can minimize, or eliminate, gastro-esophageal reflux while facilitating the emptying of the stomach into the duodenum, or an inclined left-side lateral decubitus (LLD) position, which can facilitate the reduction of reflux episodes.

[1130] Said another way, the support element 120 can have a height dimension that varies from a caudad end portion (also referred to herein as “first end portion”) of the support element 120 to a cephalad end portion (also referred to herein as “second end portion”) of

the support element 120 (e.g., nearest the user's head), with the greatest height dimension being, for example, on the cephalad end portion of the support element 120. The support element 120 can include a concave or indented portion (not shown in FIG. 1) disposed on the top surface of the support element 120, for example, at or near the cephalad end as described in more detail below with reference to specific embodiments. The concave portion can be used, for example, to relieve pressure in the user's downside axilla when the user is lying in a lateral decubitus position on the cushion system 100.

[1131] The support element 120 can also have a shape that can promote an appropriate torso angle for a user to comfortably maintain a lateral decubitus position on the support element 120 during use. For example, the support element 120 can include a curved exterior portion that can help increase the comfort of a user lying in a lateral decubitus position for an extended period of time without uncomfortable pressure or pain in a downside shoulder or arm. In some embodiments, the support element 120 can include beveled corners on the cephalad end of the support element 120 that can accommodate additional ergonomic arm and elbow placement during use of the cushion system 100.

[1132] The support element 120 can be a variety of different lengths, widths and/or thicknesses. For example, in some embodiments, the support element 120 can have a length that is shorter than a typical sized bed, such that the user's legs extend at least partially off the support element 120 during use. Such a support element 120 can be referred to as having a torso length. In some embodiments, the support element 120 can be the length of a typical bed and can be referred to herein as having a bed length. In some embodiments, the support element 120 can include multiple portions that can be stacked together.

[1133] The support element 120 can include an outer casing 121 and a cushion member 123 that can be disposed within the outer casing 121. The outer casing 121 of the support element 120 can be formed with one or more materials. For example, in some embodiments, the outer casing 121 can include a top portion on which the user contacts during use of the cushion system 100 that is formed with a first material, and a bottom portion that contacts the support surface (e.g., top surface of a bed) on which the support element 120 is disposed during use that is formed with a second material. The top portion (e.g., the top surface) of the outer casing 121 can be formed with, for example, a four-way stretch material that is highly conformable, such as, for example, cotton/spandex, nylon/spandex, polyester/spandex or blends of any blend of cotton, nylon or polyester combined with spandex or elastane, and

the bottom portion can be formed with a more robust material, such as, for example, poplin, canvas, gabardine or twill made using any combination of cotton, polyester or nylon, to provide durability.

[1134] The outer casing 121 of the support element 120 can include an opening through which the cushion member 123 can be inserted and can include a fastener such as, for example, a zipper, buttons, snaps, flaps, hook and loop fasteners or other suitable coupling method to close or partially close the opening. The cushion member 123 can be formed with one or more foam materials, such as, for example, polyurethane or rubber latex, or visco-elastic polyurethane (e.g., memory foam). In some embodiments, the cushion member 123 can include multiple different foam materials each having a different density and/or a different deflection property. In alternative embodiments, the cushion member 123 can include one or more inflatable chambers. In other alternative embodiments, the cushion member 123 can include a filler material, such as a polyester material, disposed within an inner casing. In some embodiments, the support element 120 can include multiple cushion members 123. For example, multiple cushion members 123 can be stacked together within the outer casing 121.

[1135] The riser element 122 can be removably coupled to the support element 120. For example, the riser element 122 can be coupled to the support element 120 near or proximate the second end portion (i.e., cephalad end portion) of the support element 120 and can be used to support a neck and head of a user. The riser element 122 can be coupled to the support element 120 with a variety different coupling methods. For example, in some embodiments, the riser element 122 can include straps along lateral side edges of the riser element 122 that can be coupled to the support element 120 along lateral side edges of the support element 120. The straps can include a coupling portion that can be coupled to a mating coupling portion disposed on the support element 120. For example, the coupling portion on the support element 120 can be buttons, and the coupling portion on the riser element 122 can be holes or openings configured to be coupled to the buttons. In alternative embodiments, other types of coupling portions can be included. For example, the riser element 122 can be coupled to the support element 120 with hook and loop fasteners, snaps, strings or ties, zippers, or any other suitable coupling method. In another alternative embodiment, the straps can be on the support element 120 and can be coupled to the riser

element 122. In another alternative embodiment, the support element 120 and the riser element 122 can be formed as or incorporated within a single, uniform component.

[1136] In some embodiments, the straps can include multiple coupling portions such that the riser element 122 and the support element 120 can be adjustably coupled together. For example, straps on the riser element 122 (as described above) can include multiple openings disposed at different locations along a length of the straps that can be selectively coupled to buttons on the support element 120. In alternative embodiments the support element can include multiple coupling portions to which the coupling portions on the straps can be selectively coupled. The adjustability of the position of the riser element 122 relative to the support element 120 allows the user to adjust an angle of the user's head and/or neck when supported on the riser element 122. In addition, the adjustability of the riser element 122 relative to the support element 120 can compress the riser element 122 to change or affect, for example, a height of the user's head when supported on the riser element 122. Thus, a user can position the riser element 122 to achieve a desired position and/or compression of the riser element 122 and/or to accommodate users having different sized arms.

[1137] In some embodiments, the riser element 122 can be coupled to the support element 120 such that a receiving portion is formed between the second end portion of the support element 120 and an end portion of the riser element 122. The receiving portion can be, for example, an opening, void, cavity, pocket, space or gap, etc. between the support element 120 and the riser element 122, in which a user can insert at least a portion of the user's arm. The receiving portion can be defined by flexible or conformable portions of the cushion system 100 such that the size of the receiving portion can vary as the user inserts an arm. For example, in some embodiments, a portion of the support element 120 can contact a portion of the riser element 122 such that as the user inserts an arm into the receiving portion, the user moves or flexes a portion of the support element 120 and/or a portion of the riser element 122.

[1138] During use of the cushion system 100, a user can place a downside shoulder and arm within the receiving portion when lying in a side position. Insertion of the user's arm within the receiving portion between the support element 120 and the riser element 122 can also mitigate the tendency of the user from sliding downward on the angled top surface of the support element 120 and can help stabilize the user in the lateral or side position during use of the cushion system 100. A position of the user's arm and shoulder can be adjusted

within the receiving portion between the support element 120 and the riser element 122, such that user's downside axilla rests within the concave portion of the support element 120.

[1139] The riser element 122 can include a pillow insert 125 that can be disposed within an outer casing 127. The outer casing 127 can include an opening through which the pillow insert 125 can be inserted, and can include a fastener such as, for example, a zipper, buttons, snaps, flaps, hook and loop fasteners or other suitable coupling method to close or partially close the opening. The outer casing 127 can be formed with the same or similar materials as the outer casing 121 described above for the support element 120. For example, the outer casing 127 can include a first portion formed with a four-way stretch material and a second portion formed with a more robust material such as described for support element 120. The pillow insert 125 can include an inner casing (not shown in FIG. 1) that can contain a filler material (not shown in FIG. 1) therein. The filler material can be, for example, a clustered polyester fiber material, such as, for example, any combination of polyester fibers, clustered polyester fiber, down alternative made from synthetic fibers, polystyrene beads/pellets, shredded foam, or down feathers. The inner casing of the pillow insert 125 can also be formed with a four-way stretch material as described above for the outer casing 127. The inner casing of the pillow insert 125 can also include an opening through which the filler material can be inserted, and can include a fastener such as, for example, a zipper, buttons, snaps, or other suitable coupling method to close or partially close the opening. In alternative embodiments, the inner casing may not include such an opening. For example, after the filler material has been inserted into the inner casing, the inner casing can be closed with, for example, stitching.

[1140] The four-way stretch material of the outer casing 127 of the riser element 122 described above, in conjunction with the pillow insert 125 having an inner casing formed with the four-way stretch material and having a clustered polyester fiber filler material can allow the riser element 122 to be malleable and shape-retaining. For example, in such an embodiment, the user can conform the riser element 122 to a desired thickness and/or shape for that user's needs and preference. For example, the user can conform or adjust the riser element 122 to form cavities or to otherwise fit or conform to the user's face, ear, arm, etc. The conformed shape can be maintained for an extended time period and/or until the user disperses the filler material of the pillow insert 125 by, for example, shaking or fluffing the riser element 122.

[1141] The body element 124 can include a pillow insert 129 that can be disposed within a sleeve member 131. The sleeve member 131 can include an opening or openings through which the pillow insert 129 can be inserted, and can include a fastener such as, for example, a zipper, buttons, snaps, or other suitable coupling method to close or partially close the opening(s). The pillow insert 129 can be formed the same as or similar to the pillow insert 125 described above for the riser element 122. For example, the pillow insert 129 can include an inner casing (not shown in FIG. 1) containing a filler material (not shown in FIG. 1). The filler material can be, for example, a clustered polyester fiber material, such as, for example, the materials described above for the riser element 122. The inner casing of the body element 124 can be formed with, for example, a four-way stretch material as described above for the inner casing of the riser element 122. The sleeve member 131 can be formed with, for example, a four-way stretch material as described above for the riser element 122 and the support element 120, or can be constructed of a two-way stretch material, such as, for example, jersey or interlock. Thus, as described above for the riser element 122, the body element 124 can also be manipulated, conformed, adjusted, dispersed, etc., to conform to a desired shape and/or thickness. The inner casing of the pillow insert 129 can also include an opening through which the filler material can be inserted, and can include a fastener such as, for example, a zipper, buttons, snaps, or other suitable coupling method to close or partially close the opening. In alternative embodiments, the inner casing may not include such an opening. For example, after the filler material has been inserted into the inner casing, the inner casing can be closed with, for example, stitching.

[1142] The body element 124 can have a variety of different shapes and be a variety of different sizes. For example, in some embodiments, the body element 124 can include an arc portion at a cephalad end connecting a first arm and a second arm of the body element 124. In some embodiments, the arc portion can have a curvature of, for example, substantially 180 degrees. In other embodiments, the arc portion can have a different curvature, for example, between about 30 degrees and 180 degrees. In some embodiments, the first arm and the second arm can extend parallel to each other away from the arc portion. In some embodiments, the first arm of the body element 124 can have a length that is about half a length of the second arm of the body element 124. In some embodiments, the first arm can be substantially the same length as the second arm.

[1143] The body element 124 can be reconfigurable into a variety of different shapes and configurations for use on the support element 120 and/or riser element 122 as described in more detail below. Optionally, in some embodiments, the body element 124 can be used independently of the support element 120 and the riser element 122. In some embodiments, the body element 124 and the riser element 122 can be integrally formed or incorporated within a single component. In such an embodiment, the body element 124 can be moved from a first position in which the body element 124 is unfolded and a second configuration in which the body element 124 is folded and such that a portion of the body element 124 is disposed on a portion of the riser element 122. In some embodiments, the body element 124 and the riser element 122 can be coupled by a flexible hinge such that the body element 124 can be moved between the folded configuration and the unfolded configuration. In some embodiments, the flexible hinge can be formed with, for example, a fabric material.

[1144] The sleeve member 131 of the body element 124 can be formed in a tubular shape such that the pillow insert 129 can be inserted therein through an opening defined on one end of the sleeve member 131. The sleeve member 131 can include stitching along a single outer edge such that the body element 124 can be free of stitching along an inner edge portion of the sleeve member 131 where a user typically contacts the sleeve member 131 during use. Such an embodiment can provide increased comfort for the user as many known body pillows that have such inner stitching can tend to become taut when tension is applied, resulting in an awkward and potentially painful fit for the user. In addition, the stitching being along an outer edge portion the sleeve member 131 can eliminate or reduce distortion of the body element 124 during use, which can further provide improved feel and comfort to the user. In some embodiments, stitching can be included on the body element 124 at additional targeted areas of the body element 124 as described, for example, with reference to FIGS. 26-28. The inner casing of the pillow insert 129 of the body element 124 can also be constructed in a tubular shape in the same or similar manner as the sleeve member 131. For example, the inner casing of pillow insert 129 can include stitching along an outer edge of the inner casing, and be free of stitching along an inner edge.

[1145] As described above, the user can manipulate, conform, disperse, etc., the clustered polyester fiber filler material within the body element 124 and/or the riser element 122 to create cavities or bulges to accommodate specific body parts and/or portions to accommodate the user's needs and/or preferences. The shape and/or cavity formed by the

user can be maintained for an extended time period and/or until the user disperses the filler material of the riser element 122 and/or the body element 124 by, for example, shaking the riser element 122 and/or body element 124. The combination of the four-way stretch material and clustered polyester filler material can allow for the redistribution of the filler material in an equalized manner throughout the body element 124 and/or riser element 122. The reconfigurable filler material of the body element 124 and/or the riser element 122 can also minimize undesirable and irreversible migration of the filler material, which can occur in some known cushion systems due to their non-pliable stuffing and non-stretch material. In addition, the clustered polyester fiber filler material of the body element 124 and/or the riser element 122 can be machine washed and dried without causing clumping of the filler material. The combination of the filler material and the four-way stretch outer casing 127 and inner casing of pillow insert 125 of the riser element 122, and sleeve member 131 and inner casing of the pillow insert 129 of the body element 124, provides for post-laundering redistribution of the filler material to substantially its original state.

[1146] In some embodiments, the cushion system 100 can include a side support member or portion (not shown in FIG. 1) that can be used as an alternative to the body element 124. In some embodiments, the riser element 122 and the support element 120 are formed as single component and define a receiving portion (e.g., space or opening) in which the user's arm can be disposed during use. In some embodiments, the cushion system 100 can be implemented in an adjustable bed, such as, for example, a bed used in a medical facility. In some embodiments, the cushion system 100 can be implemented with a sling-type support element and riser element. For example, in such an embodiment, the sling-type support element and riser element can include a sling portion coupled to a frame member. In some such embodiment, support legs or feet and/or or wheels, such as castors, can be coupled to the frame member. In some embodiments, the cushion system 100 can include one or more inflatable chambers that can allow a user to adjust a height and/or firmness of the cushion system 100.

[1147] In some embodiments, the cushion system 100 can include stackable elements. For example, in some embodiments, the support element 120 can include multiple separate stackable support portions each having a cushion member and an outer casing, and multiple stackable riser elements 122 each having a cushion member or pillow insert within an outer casing. In some embodiments, the cushion system 100 can include multiple stackable

elements that each include a support element and riser element formed as a single component. Example embodiments of cushion systems including such stackable elements are described in more detail below.

[1148] To use the cushion system 100, a user can removably couple the riser element 122 to the support element 120 as described above. The user can place the riser element 122 and the support element 120 on a support surface (e.g., a top surface of a bed) either before or after being coupled together. The body element 124 can be positioned on the support element 120 or with a portion of the body element 124 on the support element 120 and a portion on the riser element 120. The user can then lie on the assembled cushion system 100 in a RLD or LLD position such that the user is aligned in approximately a center portion of the support element 120. The user inserts the user's right or left arm beneath the body element 124 and within the receiving portion formed between the support element 120 and the riser element 122. Optionally, the user can adjust the position of the user's right or left arm and shoulder within the receiving portion between the support element 120 and the riser element 122, such that user's downside axilla rests within the centered concave portion of the support element 120.

[1149] With the user's arm within the space between the support element 120 and the riser element 122, the cushion system 100 can maintain the user in the inclined RLD or LLD position. Thus, the tendency of the user to slide down the angled portion of the support element 120 can be reduced or eliminated. Further illustrations and details of how a user can be positioned on the cushion system 100 are described below. In some embodiments, the support element 120 and the riser element 122 can be used without the use of the body element 124. In some embodiments, use of only the body element 124 may be desirable.

[1150] As described above, the cushion system 100 can be used as a method of treatment for GERD and/or other digestive disorders. To use the cushion system 100 for this purpose, the user can follow the steps described above for being positioned on the cushion system 100 in an inclined RLD position or an inclined LLD position. For example, in the inclined RLD position, the therapeutic cushion system 100 can serve to minimize, or eliminate, gastro-esophageal reflux while it facilitates the emptying of the stomach into the duodenum. For example, in the inclined RLD position, the exit valve (i.e., the pyloric sphincter) of the user's stomach will be positioned substantially at a bottom right side of the user's abdomen below or at an elevation lower than an elevation of the user's esophageal sphincter. Thus,

when the user remains in the inclined RLD position for a sufficient period of time, the stomach contents of the user can drain out of the stomach and into the duodenum. For example, a time period between about 1-4 hours may be needed to empty the contents of the stomach into the duodenum such that the user feels relief from symptoms associated with GERD and/or other digestive disorders. The time frame can vary depending on various factors such as for example, the user's overall health, other conditions the user may have such as diabetes, or gastroparesis, or the type and amount of food the user has consumed prior to resting on the cushion system, etc. In another example, in the inclined LLD position, a reduction in the frequency of reflux episodes of the user can result.

[1151] FIGS. 2-25 illustrate a therapeutic cushion system and methods of using the therapeutic cushion system, according to an embodiment. A therapeutic cushion system 200 (also referred to herein as a "cushion system") includes a support element 220, a riser element 222 and a body element 224. As described above for cushion system 100, the cushion system 200 can be used, for example, for the treatment of symptoms associated with GERD and/or other digestive disorders.

[1152] The support element 220 can have a variety of different shapes and/or sizes. In this embodiment, the support element 220 has a substantially wedged shape as shown in the side view of, for example, FIG. 7. Specifically, the support element 220 includes a top surface 237 that is disposed at an angle θ relative to a bottom surface 239 as shown in FIG. 7. In some embodiments, the angle θ can be, for example, between about 6 degrees and about 30 degrees. Said another way, the support element 220 has a height H1 at a first end portion 215 of the support element 220 and a height H2 at a second end portion 216 of the support element 220 and the height H2 is greater than the height H1 as shown, for example, in FIG. 7. The height H1 can be for example, up to 2 inches, and the height H2 can be between, for example, about 6 inches and 14 inches. The support element 220 also has a length L that can be, for example, between about 20 inches and 40 inches, such that the support element 220 has a torso length (as described above) and can promote an appropriate torso angle for user to comfortably maintain a lateral decubitus position on the support element 220 during use.

[1153] The support element 220 also includes a concave portion 230 (see, e.g., FIGS. 4, 5, 8 and 9) disposed on the top surface 237 of the support element 220. As described above, the concave portion 230 can be used to relieve pressure in the user's downside axilla when

the user is lying in a lateral decubitus position on the cushion system 200. The support element 220 also includes curved exterior portions that can help increase the comfort of a user lying in the lateral decubitus position for an extended period of time without uncomfortable pressure or pain in a downside shoulder or arm. In this embodiment, the support element 220 also includes beveled corners 233 on the second end portion of the support element 220 (see, e.g., FIGS. 4 and 6) that can accommodate additional ergonomic arm and elbow placement during use of the cushion system 200.

[1154] The support element 220 includes an outer casing 221, as shown, for example, in FIGS. 4 and 6-8, and a cushion member 223, as shown in FIG. 9 that can be disposed within the outer casing 221. The outer casing 221 of the support element 220 can be formed with one or more materials as described above for support element 120. For example, the outer casing 221 can include a top portion 238 (see, e.g., FIGS. 7-8) on which the user contacts during use of the cushion system 200 that is formed with a first material, and a bottom portion 236 that contacts the support surface (e.g., top surface of a bed) on which the support element 220 is disposed during use that is formed with a second material that is different than the first material. The top portion of the outer casing 221 can be formed with, for example, a four-way stretch material and the bottom portion can be formed with a more robust material as described above for support element 120. The top portion 238 and the bottom portion 236 can be coupled together with, for example, stitching. In this embodiment, the support element 220 includes buttons 228 on lateral side edges of the support element 220 (see, e.g., FIGS. 2, 3 and 6-8) that can be used to removably couple the riser element 222 to the support element 220 as described in more detail below.

[1155] The outer casing 221 of the support element 120 can also include an opening (not shown) through which the cushion member 223 can be inserted and can include a fastener (not shown) such as, for example, a zipper, buttons, snaps, flaps, or other suitable coupling method to close or partially close the opening. In this embodiment, the cushion member 223 is formed with, for example, one or more foam materials as previously described. The cushion member 223 includes a cavity 244 defined on top surface portion of the cushion member 223, as shown in FIG. 9. The cavity 244 forms the concave portion 230 of the support element 220 when the cushion member 223 is disposed within the outer casing 221.

[1156] The riser element 222 includes a pillow insert 225 that can be disposed within an outer casing 227. The outer casing 227 can include an opening 242 through which the

pillow insert 225 can be inserted as shown in FIG. 11. The outer casing 227 can include a fastener (not shown) such as, for example, a zipper, buttons, snaps, or other suitable coupling method to close or partially close the opening, as previously described for cushion assembly 100. The outer casing 227 can be formed with the same or similar materials as the outer casing 221 described above for the support element 220. For example, the outer casing 227 can include a first portion 232 formed with a four-way stretch material and a second portion 234 formed with a more robust material. The pillow insert 225 can include an inner casing 235 that can be formed with a four-way stretch material as described above and that can contain a filler material (not shown) therein. The filler material can be, for example, a clustered polyester fiber material, such as, for example, a material described above for pillow insert 125. The inner casing 235 of the pillow insert 225 can also include an opening (not shown) through which the filler material can be inserted, and can include a fastener (not shown) such as, for example, a zipper, buttons, snaps, or other suitable coupling method to close or partially close the opening. In alternative embodiments, the inner casing 235 may not include such an opening. For example, after the filler material has been inserted into the inner casing 235, the inner casing 235 can be closed with, for example, stitching.

[1157] As described above for cushion assembly 100, the four-way stretch material of the outer casing 227 of the riser element 222, in conjunction with the four-way stretch material of the inner casing 235 and the clustered polyester fiber filler material of the pillow insert 225 can allow the riser element 222 to be malleable and shape-retaining. For example, the user can conform the riser element 222 into a desired thickness and/or shape and/or form cavities or bulges to meet that user's needs and preference, as previously described.

[1158] The riser element 222 can be removably coupled to the support element 220 as shown, for example in FIGS. 2-4. For example, in this embodiment, the riser element 222 includes straps 226 along lateral side edge portions of the riser element 222 and the straps 226 each include multiple sets of button holes 240 that can be selectively coupled to the buttons 226 on the support element 220. The riser element 222 can also include bands 219 (see, e.g., FIGS. 10-12) that can be used to hold the straps 226 against the lateral side edge of the riser element 222. In this manner, the riser element 222 and the support element 220 can be adjustably coupled together to meet a user's particular needs, as described in more detail below. For example, as previously described, the riser element 222 can be coupled to

the support element 220 such that a receiving portion 258 (e.g., space, opening, void, pocket, etc.) (see, e.g., FIG. 4) is defined between the second end portion 216 of the support element 220 and the riser element 222. A user can place a downside shoulder and arm within the receiving portion 258 when lying in a RLD or LLD position. The straps 226 can be formed with, for example, the same material as the bottom portion 234 (e.g., poplin, canvas, gabardine or twill made using any combination of cotton, polyester or nylon) of the riser element 222 to provide strength to the straps 226. Similarly, the buttons 228 of the support element 220 can be disposed on the bottom portion 236 of the support element 220, which can be formed with the same material as the bottom portion 234 of the riser element 222.

[1159] As shown in FIGS. 5 and 13, in this embodiment, the body element 224 includes an arc portion 241 that has a substantially 180 degree curvature at a cephalad end portion, a first arm 247 and second arm 248 each extending from the arc portion 241 in a caudad direction. In this embodiment, the first arm 247 has a length that is shorter than a length of the second arm 248. For example, the first arm 247 can have a length, for example, about half a length of the second arm 248. The body element 224 is reconfigurable into a variety of different shapes for use on the support element 220 and/or riser element 222 as described in more detail below. Optionally, in some embodiments, the body element 224 can be used independently of the support element 220 and the riser element 222.

[1160] The body element 224 includes a pillow insert 229 (see e.g., FIG. 12) that can be disposed within a sleeve member 231. The sleeve member 231 can be formed in a tubular shape and includes a first opening 243 and a second opening 245 through which the pillow insert 229 can be inserted. The opening 243 can include a fastener (not shown) such as, for example, a zipper that can be used to close the opening 243. The fastener can also extend along an outer edge of the sleeve member 231 such that a portion 251 of the sleeve member 231 along the outer edge portion 249 can be opened to aid in insertion and removal of the pillow insert 229, as shown in FIG. 12. Optionally, a second fastener (not shown) can be included that can be used to open and close the opening 245 in a similar manner.

[1161] The tubular shape of the sleeve member 231 can be formed, for example, by sewing or stitching along an outer edge portion 249 of the sleeve member 231. Thus, the sleeve member 231 can be free of stitching along an inner edge portion 250 of the sleeve member 231 where a user typically contacts the sleeve member 231 during use. As described above, having the inner edge portion 250 free of stitching can provide increased

comfort for the user and can eliminate or reduce distortion of the body element 224 during use. In this embodiment, the sleeve member 231 also includes stitching features 252 that extend at an angle from the inner edge portion 250 to the outer edge portion 249. The stitching 252 can extend, for example, at a 45 degree angle.

[1162] The pillow insert 229 can be formed the same as or similar to the pillow insert 225 described above for the riser element 222. For example, the pillow insert 229 can include an inner casing 246 that can contain a filler material (not shown). The filler material can be, for example, a clustered polyester fiber material, as previously described for pillow insert 129. The inner casing 246 can be formed with, for example, a four-way stretch material as described above. The sleeve member 231 can be formed with, for example, a four-way stretch material as described above for the riser element 222 and the support element 220, or alternatively can be formed with, for example, a two-way stretch material as described for sleeve member 131. Thus, as described above for the riser element 222, the body element 224 can also be manipulated, conformed, adjusted, dispersed, etc., to conform to a desired shape and/or thickness. Although not shown, the inner casing 246 of the pillow insert 229 can also include an opening through which the filler material can be inserted, and can include a fastener (not shown) such as, for example, a zipper, buttons, snaps, or other suitable coupling method to close or partially close the opening. In alternative embodiments, the inner casing 246 may not include such an opening. For example, after the filler material has been inserted into the inner casing 246, the inner casing 246 can be closed with, for example, stitching.

[1163] To use the cushion system 200, the user can removably couple the riser element 222 to the support element 220 as shown in FIGS. 13, 14 and 15A-15C. Specifically, the user can select one of the set of openings 240 on the straps 226 to couple to the buttons 228 on the support element 220 such that the riser element 222 is disposed at a desired position relative to the support element 222. For example, the riser element 222 can be positioned relative to the support element 220 such that the riser element 222 is at a desired height to place the user's head and neck and at a desired longitudinal distance from the support element 220. As shown in FIG. 15A, if the user couples the first set of button holes 240 (the set furthest from an end of the straps 226) to the buttons 228, the riser element 222 will be at a maximum height. If the user uses the second set of button holes 240, as shown in FIG. 15B, the riser element 222 will be at a medium height, and if the user uses the third set of

button holes 240 (the set closest to the end of the straps 226) the riser element 222 will be at a lowest height. The user can place the riser element 222 and the support element 220 on, for example, a bed or other surface on which the user intends to use the cushion system 200 either before or after coupling the riser element 222 to the support element 220.

[1164] With the riser element 222 coupled to the support element 220, the user can place the body element 224 on top of the riser element 222 and the support element 220, as shown for example, in FIG. 14. Specifically, the arc portion 241 is placed on the riser element 222 and the second arm 248 of the body element 224 is positioned on a left side of the riser element 222 and support element 220 (as viewed in a top view of the cushion system) such that a portion of the second arm 248 (depending on its length) extends off the support element 220, as shown, for example, 2, 3, 14 and 15A-15C. Although the cushion system 200 is described below for a user positioned in a RLD position, it should be understood that the cushion system 200 can alternatively be assembled for a user to be positioned in a LLD position on the cushion system 200 in a similar manner.

[1165] The user can then lie on the assembled cushion system 200 in the RLD position such that the user is aligned in approximately a center portion of the support element 220. For example, the user can insert the user's right arm below the arc portion 241 of the body element 224 and within the receiving portion 258 between the riser element 222 and the support element 220, as shown in FIG. 16, and then out through the space on an outer side of the second arm 248 of the body element 224, as shown in FIG. 17. In other words, the user's arm can be positioned within the receiving portion 258 and the user's hand can extend out of the space. The user can check to ensure the user's body is in approximately the middle of the support element 220. Optionally, the user can adjust the position of the user's right arm and shoulder within the space between the support element 220 and the riser element 222, such that user's downside axilla rests within the centered concave portion 230 of the support element 220. The user can then place the second arm 248 (i.e., the long arm) between the user's legs and place or tuck the first arm (the short arm) behind or under the user's back, hips and/or buttocks with the user's knees in a bent position, as shown in FIG. 18. The user can situate the user's head, neck and arms until the user is in a comfortable position, as shown in FIG. 19. In some embodiments, the user's hip can be anchored or supported on the bed or support surface on which the cushion system 200 is disposed to help limit or prevent the user from sliding down the support element 220, and maintain the user

in a desired position on the cushion system 200. For example, in some embodiments, the support element 220 can have a length such that the user's hip is positioned at least partially on the bed or support surface when the user is positioned on the cushion system 200.

[1166] With the user's arm within the space between the support element 220 and the riser element 222, the cushion system 200 can maintain the user in an inclined RLD position. Thus, the tendency of the user to slide down the angled top surface portion 237 of the support element 220 can be reduced or eliminated. As described above, the user can also manipulate, conform, disperse, etc., the clustered polyester fiber filler material within the body element 224 and/or the riser element 222 to create cavities or bulges to accommodate specific body parts and/or portions related to its use for GERD or other medical conditions to accommodate the user's needs and/or preferences, for example, a user may accommodate a breathing apparatus or other similar device.

[1167] FIGS. 20-23 illustrate different alternative configurations for using the cushion system 200. FIG. 20 illustrates the body element 224 disposed with the second arm 228 folded over the arc portion 241. FIG. 21 illustrates the body element 224 with the second arm 248 folded toward the first arm 247 such that the second arm 248 does not extend substantially off the support element 220. FIGS. 22 and 23 illustrate use of the cushion system 200 with the riser element 222 and the support element 220 disposed in an alternative position. Specifically, FIG. 22 illustrates the support element 220 disposed in an upright position with the second end portion 216 supported on a support surface (e.g., a bed or a floor) and the riser element 222 disposed in an upright position proximate to the support element 220. As shown in FIG. 23, the body element 224 can be positioned against the riser element 222 and the support element 220 such that a user can use the cushion system 200 as a back rest in a seated or semi-seated position. FIG. 24 illustrates use of the cushion system 200 without the riser element 222. As shown in FIG. 24, the body element 224 can be placed on the support element 220.

[1168] FIGS. 24(A)-24(J) each illustrate a user using the cushion system 200 in various configurations and positions. FIG. 24(A) illustrates the user positioned in an inclined LLD position. In other words, the body element 224 is positioned on the support element 220 and the riser element 222 with the second arm 248 (i.e., the long arm) on a right side of the cushion system 200 (as viewed from a top view of the cushion system 200). FIGS. 24(B) and 24(C) illustrate the user in an inclined RLD position, as described above, for example,

with reference to FIGS. 16-19. FIGS. 24(D) and 24(E) illustrate the body element 224 in a folded position similar to the configuration shown with reference to FIG. 20, and the user positioned in an inclined supine position on the cushion system 200. FIGS. 24(F) and 24(G) illustrate the body element 224 folded position similar to the configuration shown with reference to FIG. 21 and the user positioned in a prone position on the cushion system 200. FIG. 24(I) illustrates the cushion system 200 in an upright reclined configuration similar to the configuration shown with reference to FIGS. 22 and 23, and FIG. 24(H) illustrates the cushion system 200 in a similar configuration as with FIG. 24(I) but with the body element 224 wrapped around to the front of the user. This position can be used, for example, to support the user's hand(s), a book, or in the case of a nursing mother, a nursing infant.

[1169] FIG. 24(J) illustrates the cushion system 200 with a user in a right side inclined position similar to the position shown in FIG. 24(C), except in FIG. 24(J) the second arm 248 (the long arm) of the body element 224 running along the user's back and tucked or placed forward between the user's knees. This position can allow the user to change from a RLD position to a LLD position (and vice versa) without having to flip over the body element 224.

[1170] FIG. 25 illustrates use of a cushion system 200' that is similar to the cushion system 200. The cushion system 200' includes a support element 220' that can be configured the same as or similar to the support element 220. In this embodiment, the support element 220' has a longer length than the support element 220 and can be used without a riser element. As shown in FIG. 25, the support element 220' can be used with a body element 224 described above, or with another body element as described herein.

[1171] FIGS. 26-28 each illustrate different embodiments of a body element showing various stitching features. The body elements of FIGS. 26-28 can each be configured the same as or similar to and function the same as or similar to the embodiments of a body element described above. FIG. 26 illustrates a body element 324 that is similar to the body element 224 described above and includes a sleeve member 331 that has stitching 353 along an outer edge portion 349 of the body element 324 and a pair of stitching features 352 disposed at angles and extend from an inner edge portion 350 of the body element 324 to the outer edge portion 349. FIG. 27 illustrates a body element 424 that includes a sleeve member 431 that has stitching 453 along an outer edge portion 449 and a pair of stitching features 452 each disposed at an angle and extending from an inner edge portion 450 to the

outer edge portion 449. The body element 424 also includes a stitching feature 454 that extends from the inner edge portion 450 to the outer edge portion 449 and is disposed between the stitching features 452. FIG. 28 illustrates a body element 524 that includes a sleeve member 531 that has stitching 553 along an outer edge portion 549 of the body element 524 and four stitching features 552 that extend at an angle from an inner edge portion 550 of the body element 524 to the outer edge portion 549 of the body element 524.

[1172] The stitching features 352, 452, 454, 552 described above can be disposed on the respective body elements 324, 424, 524 at a substantially equal distance from each other or at different distances from each other. Further, in alternative embodiments, more or less stitching features can be included on a body element of a cushion system described herein.

[1173] FIGS. 29 and 30(A)-30(I) illustrate different embodiments of a body element that can be used alone or within a cushion system as described herein. Each of the body elements described with respect to FIGS. 29 and 30(A)-30(I) can be configured the same as or similar to and function the same as or similar to the embodiments of a body element described above. FIG. 29 illustrates a body element 624. The body element 624 includes a first arm 647 and a second arm 648 and a sleeve member 631 that has an inner edge portion 650 and an outer edge portion 649 in which a pillow insert (not shown) can be disposed. The sleeve member 631 includes stitching features 652 similar that extend at an angle from the inner edge portion 650 to the outer edge portion 649 and can include stitching (not shown) along the outer edge portion 649 as described above for previous embodiments. In this embodiment, the second arm 648 includes an end portion 655 that is disposed at an angle relative to a remainder of the second arm 648. The end portion 655 can be disposed, for example, at an angle of up to about 25 degrees. A stitching feature 656 can be disposed at the start of the bend portion 655. The first arm 647 includes a rounded or curved end portion 657, and the end of the end portion 655 can optionally be similarly rounded. FIGS. 30(A)-30(I) each illustrate different embodiments of a body element having different shapes and sizes.

[1174] FIGS. 31(A)-31(E) each illustrate further different embodiments of a body element that can be used alone or within a cushion system as described herein and that include various different filler zoning options. Filler zoning can allow various filler materials and/or filler materials with different densities to be placed at targeted locations within the body element. Filler zones can be formed, for example, by way of internal fabric

baffles, sewn-in segmentation, or by self-contained individual insert members. Each zone within a body element can be accessed and/or inserted within a body element during manufacturing, for example, via a semi-permanently stitched closure. Alternatively, each zone can be accessed by a user (e.g., during in-home use) via a closure member, including, for example, zipper(s), snap(s), button(s), hook and loop fasteners, etc. Each embodiment of a body element described with reference to FIGS. 31(A)-31(E) can include the same or similar features, and can function the same or similar to, other embodiments of a body element described herein, and therefore certain details are not described with reference to FIGS. 31(A)-31(E).

[1175] FIG. 31(A) illustrates a body element 2124 that includes a first filler zone A and a second filler zone B. FIG. 31(B) illustrates a body element 2224 that includes a first filler zone A and a second filler zone B. FIG. 31(C) illustrates a body element 2324 that includes a first filler zone A, a second filler zone B, and a third filler zone C. FIG. 31(D) illustrates a body element 2424 that includes a first filler zone A, a second filler zone B, and a third filler zone C. FIG. 31(E) illustrates a body element 2524 that includes a first filler zone A, a second filler zone B, a third filler zone C, a fourth filler zone D and a fifth filler zone E.

[1176] The fillers zones shown and described with respect to FIGS. 31(A)-31(E) are example embodiments of body elements having various quantity and types of filler zones. It should be understood that alternative embodiments can include a different quantity, size and/or shape of filler zone. Further, although not shown with respect to other embodiments of a body element described herein, it should be understood that other embodiments of a body element can include filler zones.

[1177] FIGS. 32(A), 32(B) and 33-35 illustrate another embodiment of a therapeutic cushion system. A therapeutic cushion system 700 (also referred to herein as a “cushion system”) includes a support element 720, a riser element 722 and a body element 724. The support element 720, riser element 722 and body element 724 can each be constructed the same as or similar to, and can function the same as or similar to, the support elements, riser elements, and body elements described above for previous embodiments. Therefore, some details are not described below with respect to support element 720, riser element 722 and/or the body element 724.

[1178] The support element 720 can be formed the same as or similar to the support elements described above. For example, the support element 720 can include a first end portion 715 and a second end portion 716 and a top surface 737 that is angled relative to a bottom surface 739, as shown, for example, in FIG. 33.

[1179] In this embodiment, the body element 724 and the riser element 722 are formed as a single component and the body element 724 can be moved between a first unfolded configuration, as shown in FIG. 32(B), and a second folded configuration, as shown in FIG. 32(A). A fabric hinge portion 763 is formed between a portion of the body element 724 and a portion of the riser element 722 that allows a user to fold a portion of the body element 724 for use. Specifically, the body element 724 includes a first arm 747 connected to the riser element 722 by the fabric hinge portion 763, and a second arm 748. When in the second folded configuration, the first arm 747 is substantially disposed on the riser element 722 as shown in FIGS. 32(A), 32(B) and 33-35.

[1180] A user can use the cushion system 700 in the same or similar manner as described above for previous embodiment. For example, as shown in FIG. 34 the user can place the cushion system 700 on bed, and position the combination riser element 722 and body element 724 proximate to the second end portion 716 of the support element 720. For example, the riser element 722 can be positioned at a desired distance from the support element 720 such that a receiving portion (e.g., a gap, opening, pocket, etc.) 758 is defined between the riser element 722 and the support element 720. The body element 724 can be folded over the riser element 722 as described above and as shown for example, in FIGS. 34 and 35. As shown in FIG. 35, the user can be positioned on the cushion system 700 in an inclined side position with the user's arm disposed within the receiving portion 758.

[1181] FIGS. 36-41 illustrate an embodiment of a therapeutic cushion system that includes a bed length support element. A therapeutic cushion system 800 (also referred to herein as a "cushion system") includes a support element 820, a riser element 822 and a side support member 864. The support element 820 and the riser element 822 can each be constructed the same as or similar to, and can function the same as or similar to, the support elements and riser elements, respectively, described above for previous embodiments. Therefore, some details with respect to the support element 820 and riser element 822 are not described below. The cushion system 800 can also include an optional pillow 859 or the pillow 859 can be a pillow provided by a user.

[1182] In this embodiment, the support element 820 and the riser element 822 are formed as a single component and define a receiving portion 858 between the support element 820 and the riser element 822. The receiving portion 858 can be used as a shoulder relief area for the user to place a portion of a user's arm when using the cushion system 800. In this embodiment, the support element 820 and the riser element 822 can collectively have a wedge shape. Specifically, the support element 820 includes a top surface 837 that is angled relative to a bottom surface 839 between a first end portion 815 and a second end portion 816. The riser element 822 includes a top surface 817 that is angled relative to a bottom surface 818 that is continuous with the bottom surface 839 of the support element 820.

[1183] The support element 820 and the riser element 822 can be placed on a support surface S (as shown in FIGS. 37, 38 and 41), such as, for example, a bed, box spring, bed foundation or floor, for use by a user. The support element 820 and the riser element 822 collectively have a length that is substantially the same as a length of the support surface (e.g., bed) on which it is to be used as shown in FIGS. 37, 38 and 41. In alternative embodiments, the cushion system 800 can have a torso size as described above, for example, for cushion systems 200 and 700.

[1184] The support element 820 can include a cushion member (not shown) and a concave portion 830 as described above for previous embodiments. The cushion member can be formed with, for example, one or more foam materials as described above for previous embodiments. The riser element 822 can include a pillow insert (not shown) and a riser foam portion (not shown). The riser foam portion can be integral with the cushion member of the support element 820 or can alternatively be a separate foam portion or portions constructed the same as or similar to the cushion member. An outer casing 861 can encase both cushion member of the support element and the pillow insert and foam portion of the riser element. The outer casing 861 can be formed with one or more materials as described above, for example, for outer casing 121 and outer casing 127.

[1185] The pillow insert can be disposed, for example, within a pocket formed in the riser foam portion or can be disposed on top of the riser foam portion. The pillow insert can include an inner casing (not shown) and filler material (not shown) as described above for previous embodiments such that the riser element 822 can include a compliant region to allow a user to form cavities or bulges to accommodate specific body parts and/or portions to accommodate the user's needs and/or preferences.

[1186] The side support member 864 can be placed on the support element 820 during use and used to help maintain a user in a lateral position. In alternative embodiments, the side support member 864 can be fixedly attached to the support element 820 or integrally formed with the support element 820. In this embodiment, the side support member 864 has a wedge shape with a substantially triangular cross-section as shown in FIG. 40. In alternative embodiments, the side support member 864 can have different shapes, sizes, and cross-sections, such as, for example, the cross-sectional views of alternative embodiments of a side support member 864-1, 864-2, 864-3 and 864-4 illustrated in FIGS. 42(A)-(D). The side support member 864 can include an outer casing 865 (see, e.g., FIG. 39) and an insert member 866 (see, e.g., FIG. 40). The outer casing 865 can be constructed, for example, the same as or similar to the outer casings 125 and 127 or the sleeve member 131 described above. The insert member 866 of the side support member 864 can be formed with, for example, one or more foam materials, or can include a filler material such as the filler material described above, for example, for pillow insert 125.

[1187] The user can be positioned on the cushion system 800 as described above for previous embodiments, in an inclined RLD or LLD position, depending on the particular needs of the user, with the user's right or left arm disposed within the receiving portion 858. As described above, the side support member 864 can be placed on the support element 820 and used to help maintain the user in the RLD or LLD position. For example, as shown in FIG. 39, the side support 864 can be disposed on the support element 820 on either a right or left side of the support element 820.

[1188] FIG. 41 illustrates the cushion system 800 with an optional body element 824 instead of the side support member 864 and pillow 859. The body element 824 can be formed the same as or similar to and function the same as or similar to the body elements described above for previous embodiment. When using the body element 824, the user may not use the pillow 859.

[1189] FIGS. 43-47 illustrate an embodiment of a therapeutic cushion system that is similar to the cushion system 800. A therapeutic cushion system 900 (also referred to herein as a "cushion system") includes a support element 920, a riser element 922 and a side support member 964. The support element 920, riser element 922 can each be constructed the same as or similar to, and can function the same as or similar to, the support elements

and riser elements described above for previous embodiments. The cushion system 900 can also include an optional pillow 959 or the pillow 959 can be a pillow provided by a user.

[1190] In this embodiment, the support element 920 and the riser element 922 are integrally formed as a single component and collectively have a wedge shape. In this embodiment, the support element 920 and the riser element 922 collectively have a top surface 937 that is angled relative to a bottom surface 939 between a first end portion 915 and a second end portion 916, as shown, for example, in FIG. 43. The support element 920 and the riser element 933 can be formed the same as or similar to, and include the same or similar features as described above for the support element 820 and the riser element 822, except in this embodiment, the support element 920 and the riser element 922 do not define a space or receiving portion in which a user's arm can be disposed. The support element 920 and the riser element 922 can be placed on a support surface S (as shown in FIGS. 44, 45 and 47), such as, for example, a bed, for use by a user. The support element 920 and the riser element 922 collectively have a length that is substantially the same as a length of the support surface (e.g., bed) on which it is to be used as shown in FIGS. 44, 45 and 47. In alternative embodiments, the cushion system 900 can have a torso size as described above, for example, for cushion systems 200 and 700.

[1191] The side support member 964 can also be constructed the same as or similar to and include the same features as described above for side support member 864. The side support member 964 can be placed on the support element 920 during use and used to help maintain a user in a side position. In alternative embodiments, the side support member 964 can be fixedly attached to the support element 920 or integrally formed with the support element 920.

[1192] The user can be positioned on the cushion system 900 as described above for previous embodiments, in an inclined RLD or LLD position, depending on the particular needs of the user. As described above, the side support member 964 can be placed on the support element 920 and used to help maintain the user in the inclined RLD or LLD position. For example, as shown in FIG. 46, the side support 964 can be disposed on the support element 920 on either a right or left side of the support element 920. FIG. 47 illustrates the cushion system 900 with an optional body element 924 instead of the side support member 964 and optional pillow 959. The body element 924 can be formed the

same as or similar to and function the same as or similar to the body elements described above for previous embodiment.

[1193] FIGS. 48-52 illustrate a sling-type therapeutic cushion system, according to an embodiment. A therapeutic cushion system 1000 (also referred to herein as a “cushion system”) includes a support element 1020, a riser element 1022 and an optional body element 1024 (shown in FIG. 51). In this embodiment, the support element 1020 and the riser element 1022 are integrally formed and include a sling member 1067 coupled to a frame member 1068. The support element 1020 has a wedge shape as shown, for example, in the side view of FIG. 48.

[1194] The sling member 1067 can be formed with, for example, a fabric material such as, for example, any suitable stretch or non-stretch fabric material, such as for example, canvas or nylon. The frame member 1068 can be formed with, for example, one or more metal, wood or plastic materials. The sling member 1067 can be coupled to the frame member 1068 with a variety of different coupling methods. For example, the sling member 1067 can be coupled to the frame member 1068 with ties, straps, rivets, buttons, snaps, hook and loop fasteners, or any other suitable coupling method, such that the sling member 1067 is sufficiently taut to support a user. The sling member 1067 defines a receiving portion 1058 (e.g., opening, space, gap, etc.) through which a user can place the user’s right or left arm during use of the cushion system 1000. The cushion system also includes a lower pad member 1069 such that when the user’s arm is extended through the opening 1058, the arm can rest on the pad member 1069.

[1195] As shown in FIG. 51, the cushion system 1000 can also include a body element 1024. The body element 1024 can be formed the same as or similar to, and can be used in the same or similar manner as, other body elements described herein, such as, for example, the body element 624 shown in FIG. 29. For example, the body element 1024 can be help maintain the user in a side position and help the user from sliding down the angled portion of the support element 1022 when using the cushion system 1000. During use the cushion system 1000 can be placed on a support surface S, such as a bed, as shown in FIG. 53.

[1196] FIG. 53 illustrates the cushion system 1000 having a bed size length and FIG. 54 illustrates an alternative embodiment of the cushion system 1000 having a torso size length. The cushion system 1000’ can be formed the same as or similar to the cushion system 1000

and can function the same as or similar to the cushion system 1000 and can be supported on a support surface S as shown in FIG. 54. For example, the cushion system 1000' includes a support element 1020' and a riser element 1022' that are integrally formed and define an opening (not shown) that can be used as a shoulder relief area to place the user's arm. The support element 1020' and riser element 1022' include a sling member 1067' coupled to a frame member 1068' and a pad member 1069' disposed below the opening.

[1197] FIG. 55 illustrates an embodiment of a cushion system that includes inflatable air chambers. A therapeutic cushion system 1100 (also referred to herein as a "cushion system") includes a support element 1120 and a riser element 1122. Although not shown, the cushion system 1100 can also include a body element as described above for previous embodiments. In this embodiment, the support element 1120 includes a cushion member 1123 and an inflatable chamber 1170 each encased within an outer casing 1121. Similarly, the riser element 1122 includes a cushion member 1171 and an inflatable chamber 1172 each encased within an outer casing 1127. The cushion member 1123 and the cushion member 1171 can be formed with, for example, one or more foam materials as described above, for example, for cushion member 123. The outer casing 1121 and the outer casing 1127 can each be formed with, for example, one or more materials, as described above, for example, with respect to outer casing 121 and outer casing 127.

[1198] As described above for previous embodiments, the support element 1120 can include a first end portion 1115 and a second end portion 1116 and a top surface 1137 that is angled relative to a bottom surface 1139 between the first end portion 1115 and the second end portion 1116. The support element 1120 can also include a concave portion (not shown) and beveled or angled corners (not shown) disposed on the second end portion 1116 of the support element 1120, as described above for previous embodiments. In some embodiments, the riser element 1122 can also include a pillow insert portion (not shown) that can be disposed, for example, within a pocket formed in the cushion member 1171 of the riser element 1122 or can be disposed on top of the cushion member 1171. The pillow insert portion can include an inner casing (not shown) and filler material (not shown) as described above for previous embodiments such that the riser element 1122 can include a compliant region to allow a user to form cavities or bulges to accommodate specific body parts and/or portions to accommodate the user's needs and/or preferences.

[1199] The inflatable air chamber 1170 can be coupled to an air pump device 1173 and the inflatable chamber 1172 can be coupled to an air pump device 1174. The air pump device 1173 and/or the air pump device 1174 can be, for example, a manual pump in which the user can manually pump air into and out of the inflatable air chambers 1170 and 1172, and adjust the air pressure within the inflatable air chambers 1170 and 1172. In alternative embodiments, the air pump device 1173 and/or the air pump device 1174 can be an automated pump and include controls (not shown) for the user to adjust the air pressure within the inflatable air chambers 1170 and 1172. In alternative embodiments, a single air pump device (e.g., manual or automated) can be used to pump air into and out of both the inflatable air chambers 1170 and 1172.

[1200] The cushion system 1100 can be used the same as or similar to the cushion systems described above for previous embodiments. In this embodiment, the user can place the support element 1120 and the riser element 1122 on a support surface S (e.g., a bed) such that the second end portion 1116 (e.g., the highest end) of the support element 1120 is disposed at a desired distance from the riser element 1122. Thus, a receiving portion 1158 between the support element 1122 and the riser element 1120 can be defined such that the user can place an arm within the receiving portion 1158 during use of the cushion system 1100. The user can also adjust the air pressure within the air chambers 1170 and 1172 such that the support element 1120 and the riser element 1122 each have a desired firmness. As described above for previous embodiments, the support element 1120 and the riser element 1122 can collectively have a bed size length that is substantially the same as a length of the support surface (e.g., bed) on which it is to be used, or can alternatively have a torso size length as described above, for example, for cushion systems 200 and 700.

[1201] FIG. 56 illustrates another embodiment of a cushion system that includes an air chamber. A therapeutic cushion system 1200 (also referred to herein as a “cushion system”) includes a support element 1220 and a riser element 1222 and can also include a body element (not shown) as described above for previous embodiments. In this embodiment, the support element 1220 and the riser element 1222 are integrally formed and include a cushion member 1223, a cushion member 1271 and an inflatable chamber 1170 each encased within an outer casing 1261. The cushion member 1223 and the cushion member 1271 can be integrally formed as a single component or be separate components. The cushion member 1223 and the cushion member 1271 can each be formed with, for example, one or more

foam materials as described above, for example, for cushion member 123. The outer casing 1621 can be formed with, for example one or more materials, as described above, for example, for outer casing 121 and outer casing 127. The support element 1220 and the riser element 1222 define a receiving portion (e.g., an opening, space, gap, pocket, etc.) 1258 in which a user can place an arm during use of the cushion system 1200.

[1202] As described above for previous embodiments, the support element 1220 can include a first end portion 1215 and a second end portion 1216 and a top surface 1237 that is angled relative to a bottom surface 1239 between the first end portion 1215 and the second end portion 1216. The support element 1220 can also include a concave portion (not shown) and beveled or angled corners (not shown) disposed on the second end portion 1216, as described above for previous embodiments. In some embodiments, the riser element 1222 can also include a pillow insert portion (not shown) that can be disposed, for example, within a pocket formed in the cushion member 1271 of the riser element 1222 or can be disposed on top of the cushion member 1271. The pillow insert portion can include an inner casing (not shown) and filler material (not shown) as described above for previous embodiments such that the riser element 1222 can include a compliant region to allow a user to form cavities or bulges to accommodate specific body parts and/or portions to accommodate the user's needs and/or preferences.

[1203] The inflatable air chamber 1270 can be coupled to an air pump device 1273. The air pump device 1273 can be, for example, a manual pump in which the user can manually pump air in and out of the inflatable air chamber 1273 and adjust the air pressure within the inflatable air chambers 1270. In alternative embodiments, the air pump device 1273 can be an automated pump and include controls (not shown) for the user to adjust the air pressure within the inflatable air chamber 1270. In alternative embodiments, the riser element 1222 and the support element 1220 can each include an inflatable air chamber and two separate air pump devices (e.g., manual or automated) can be used to pump air into and out of both the inflatable air chambers, in a similar manner as described above for cushion system 1100.

[1204] The cushion system 1200 can be used the same as or similar to the cushion systems described above for previous embodiments. In this embodiment, the user can place the cushion system 1200 on a support surface S (e.g., a bed) and can adjust the air pressure within the air chamber 1270 such that the support element 1220 and the riser element 1222 each have a desired firmness. As described above for previous embodiments, the support

element 1220 and the riser element 1222 can collectively have a bed size length that is substantially the same as a length of the support surface (e.g., bed) on which it is to be used, or can alternatively have a torso size length as described above, for example, for cushion systems 200 and 700.

[1205] FIGS. 57 and 58 illustrate an embodiment of a cushion system that includes stackable portions to allow a user to assemble the cushion system to have a desired thickness and/or firmness. A therapeutic cushion system 1300 (also referred to herein as a “cushion system”) includes a support element 1320 and a riser element 1322. Although not shown, the cushion system 1300 can also include a body element as described above for previous embodiments. In this embodiment, the support element 1320 includes multiple stackable support elements 1375, 1376 and 1377 and the riser element 1322 includes multiple stackable riser elements 1378, 1379 and 1380 (collectively also referred to herein as stackable elements). Although the support element 1320 is shown with three stackable support elements and the riser element 1322 is shown with three stackable riser elements, it should be understood that more or less stackable support elements and stackable riser elements can alternatively be included. In addition, the support element 1320 can include a different number of stackable support elements than the stackable riser elements of the riser element 1322.

[1206] The stackable elements 1375-1380 can each include a cushion member encased within an outer casing as described above for previous embodiments of a support element (e.g., support element 123). The cushion members can be formed with, for example, one or more foam materials, as described above, for example, for cushion member 123. Each stackable element 1375-1380 can have a cushion member formed with a foam material having the same or different density. The stackable support elements 1375-1377 can be selectively stacked to form the support element 1320 such that the support element 1320 has a desired height or thickness and/or a desired firmness. Similarly, the stackable riser members 1378-1380 can be selectively stacked to form the riser element 1322 such that the riser element 1322 has a desired height or thickness and/or a desired firmness.

[1207] Each of the stackable support elements 1375-1377 of the support element 1320 can include an angled top surface such that the support element 1320 has a wedge shape with a top surface 1337 that is angled relative to a bottom surface 1339 from a first end portion 1315 to a second end portion 1316, as shown in FIG. 57. In alternative

embodiments, each of the stackable elements 1375-1377 can have a top surface that is substantially horizontal or flat, or can have a top surface that is tiered or stepped. Each of the stackable support elements 1375-1377 of the support element 1320 can also include a concave portion (not shown) at, for example, a substantially center location on the highest or second end portion 1316 of the support element 1320, and beveled or angled corners (not shown) as described above for previous embodiments.

[1208] Each of the stackable elements 1378-1380 include a top surface that is at least partially substantially horizontal or flat. In alternative embodiments, each of the stackable elements 1378-1380 can have a top surface that is angled or can be tiered or stepped. In some embodiments, the riser element 1322 can also include a pillow insert portion (not shown) that can be disposed, for example, within a pocket formed in at least one of the stackable riser elements, such as, the stackable riser element 1378 intended to be used as a top of the riser element 1322. The pillow insert portion can include an inner casing (not shown) and filler material (not shown) as described above for previous embodiments such that the stackable riser element 1378 of the riser element 1322 can include a compliant region to allow a user to form cavities or bulges to accommodate specific body parts and/or portions to accommodate the user's needs and/or preferences. In some embodiments, the stackable riser element 1378 may not include a pillow insert, but instead include filler material disposed on a top portion of the cushion member of the stackable riser element 1378.

[1209] The cushion system 1300 can be used the same as or similar to the cushion systems described above for previous embodiments. In this embodiment, the user can place the support element 1320 and the riser element 1322 on a support surface S (e.g., a bed) such that the second end portion 1316 (e.g., the highest end) of the support element 1320 is disposed at a desired distance from the riser element 1322. Thus, a receiving portion 1358 between the support element 1322 and the riser element 1320 can be defined such that the user can place an arm within the receiving portion 1358 during use of the cushion system 1300. For example, the user can stack one or more of the stackable support elements 1375-1377 of the support element 1320 such that the support element 1320 is at a desired height (or has a desired thickness), and has a desired firmness. The user can also stack one or more of the stackable riser elements 1378-1380 of the riser element 1322 such that the riser element 1322 is at a desired height (or has a desired thickness), and has a desired firmness.

The user can stack the stackable elements 1375-1380 on the support surface S, or can stack the stackable elements 1375-1380 first then place the assembled support element 1320 and assembled riser element 1322 on the support surface S. As described above for previous embodiments, the support element 1320 and the riser element 1322 can collectively have a bed size length that is substantially the same as a length of the support surface (e.g., bed) on which it is to be used, or can alternatively have a torso size length as described above, for example, for cushion systems 200 and 700.

[1210] FIGS. 59 and 60 illustrate another embodiment of a cushion system that includes stackable portions to allow a user to assemble the cushion system to have a desired thickness and/or firmness. A therapeutic cushion system 1400 (also referred to herein as a “cushion system”) includes a support element 1420 and a riser element 1422 and can also include a body element (not shown) as described above for previous embodiments. In this embodiment, the support element 1420 and the riser element 1422 are formed as a single cushion element and include multiple stackable cushion elements 1475, 1476 and 1477 that can be stacked on top of each other to form the support element 1420 and riser element 1422. At least one of the stackable cushion elements 1475-1477 can define a receiving portion 1458 between the riser element 1422 and the support element 1420 in which a user can place an arm during use of the cushion system 1400. For example, as shown in FIGS. 59-60, the stackable cushion element 1475 defines the receiving portion 1458. Although the combined support element 1420 and the riser element 1422 is shown with three stackable cushion elements, it should be understood that more or less stackable cushion elements can alternatively be included.

[1211] The stackable cushion elements 1475-1477 can each be formed, for example, similar to the stackable support elements and stackable riser elements described above for cushion system 1300. For example, the stackable cushion elements 1475-1480 can each include a cushion member formed with one or more foam materials, as described above, for example, for cushion member 123. Each of the cushion members 1475-1477 can be formed with a foam material having the same or different density.

[1212] Each cushion member 1475-1477 can also include an outer casing formed with, for example one or more materials, as described above, for example, for outer casing 121 and outer casing 127. Each of the cushion members 1475-1477 can include a top surface angled relative to a bottom surface such that the support element 1420 has a wedge shape

with a top surface 1437 that is angled relative to a bottom surface 1439 from a first end portion 1415 to a second end portion 1416, as shown in FIG. 59. In alternative embodiments, each of the stackable elements 1475-1477 can have a top surface that is substantially horizontal or flat, or can have a top surface that is tiered or stepped. Each of the stackable cushion elements 1475-1477 can also include a concave portion (not shown) at, for example, a substantially center location on the highest portion of the stackable cushion element and beveled or angled corners (not shown), as described above for previous embodiments.

[1213] Each of the stackable elements 1478-1380 includes a top surface that is at least partially substantially horizontal or flat. In alternative embodiments, each of the stackable elements 1478-1480 can have a top surface that is angled or can be tiered or stepped. As described above for riser element 1322, the riser element 1422 can also include a pillow insert portion (not shown) that can be disposed, for example, within a pocket formed in the stackable cushion element 1475. The pillow insert portion can include an inner casing (not shown) and filler material (not shown) as described above for previous embodiments such that the riser element 1422 can include a compliant region to allow a user to form cavities or bulges to accommodate specific body parts and/or portions to accommodate the user's needs and/or preferences. In some embodiments, the stackable cushion element 1475 may not include a pillow insert, but instead include filler material disposed on a top portion of the cushion element 1475.

[1214] The cushion system 1400 can be used the same as or similar to the cushion system 1300 described above. In this embodiment, the user can place the cushion system 1400 (i.e., collectively the support element 1420 and the riser element 1422) on a support surface S (e.g., a bed). For example, the user can stack one or more of the stackable cushion elements 1475-1477 such that the support element 1420 and the riser element 1422 are at a desired height (or have a desired thickness), and have a desired firmness. As described above for previous embodiments, the support element 1420 and the riser element 1422 collectively can have a bed size length that is substantially the same as a length of the support surface (e.g., bed) on which it is to be used, or can alternatively have a torso size length as described above, for example, for cushion systems 200 and 700.

[1215] FIGS. 61-64 illustrate an embodiment of a cushion system that includes a support element with side bolster portions that can be used to help maintain a user in a lateral

position on the cushion system. A therapeutic cushion system 1500 (also referred to herein as a “cushion system”) includes a support element 1520 that can be used with a riser element 1522 (see FIG. 62), such as, for example, the riser element 1122 or 1322. The cushion system 1500 also includes a first side bolster portion 1582 and a second side bolster portion 1583 disposed on an opposite side of the support element 1520. The side bolster portions 1582 and 1583 can be used to help maintain a user in a lateral position during use of the cushion system 1500. In this embodiment, the side bolster portions 1582 and 1583 each include a first top surface portion 1585 and a second top surface portion 1586 disposed at a different angle than the first top surface portion 1586 relative to a bottom surface 1539 of the support element 1520. The side bolster portions 1582 and 1583 also each include an angled or beveled portion 1581 as shown for example in FIGS. 61 and 62.

[1216] The support element 1520 also includes an angled top surface 1537, a concave portion 1530 and beveled or angled portions 1533 at a second end of the support element 1520. As with previous embodiments, the support element 1520 can include a cushion member (not shown) that can be formed with, for example, one or more foam materials, and an outer casing 1521 that can encase the cushion member and the side bolster portions 1582 and 1583. In some embodiments, the side bolster portions 1582 and 1583 can be formed with a foam material that has a different density than the foam material forming the support element 1520. In alternative embodiments, the side bolster portions 1582 and 1583 can each be formed as separate components (i.e., separate from the support element 1520 similar to the side support members 864 and 964 described above).

[1217] The cushion system 1500 can be used the same as or similar to the cushion systems described above for previous embodiments. For example, in this embodiment, the user can place the support element 1520 on a support surface such that the second end (e.g., the highest end) of the support element 1520 is disposed at a desired distance from the riser element 1522 (shown in FIG. 62). Thus, a receiving portion 1558 between the support element 1520 and the riser element 1522 can be defined such that the user can place an arm within the receiving portion 1558 during use of the cushion system 1500. For example, the user can position the user’s body in a lateral position (i.e., either a right-side lateral position or a left-side lateral position) and place the user’s arm within the open space 1558. An optional body element (not shown) can also be used in the same or similar manner as described above for previous embodiments. As described above for previous embodiments,

the support element 1520 can be sized such that the support element 1520 and the riser element 1522 collectively have a bed size length, or can alternatively have a torso size length.

[1218] FIGS. 65 and 66 each illustrate an embodiment of a cushion system that includes side bolster portions. FIG. 65 illustrates a therapeutic cushion system 1600 (also referred to herein as a “cushion system”) that includes a support element 1620 and a riser element 1622 formed as a single component. The support element 1620 and the riser element 1622 collectively define a receiving portion 1658 in which a user can place an arm during use of the cushion system 1600. As with the previous embodiment, the cushion system 1600 also includes a first side bolster portion 1682 and a second side bolster portion (not shown in FIG.65) on an opposite side of the support element 1620 that can each be used to help maintain a user in a lateral position during use of the cushion system 1600. As with the previous embodiment, the first side bolster portion 1682 and the second side bolster portion (not shown) each include a first top surface portion 1685 and a second top surface portion 1686 disposed at a different angle than the first top surface portion 1685 relative to a bottom surface 1639 of the support element 1620. The first side bolster portion 1682 (and the second side bolster portion) also each include an angled or beveled portion 1681.

[1219] The support element 1620 includes an angled top surface 1637, and can include a concave portion (not shown) at a second end of the support element 1620, as described above for previous embodiments. As with previous embodiments, the support element 1620 can include a cushion member (not shown) that can be formed with, for example, one or more foam materials, and an outer casing 1661 can encase the cushion member, the first side bolster portion 1682 and the second side bolster portion (not shown). The outer casing 1661 can also encase a cushion member (not shown) and pillow insert portion (not shown) of the riser element 1622.

[1220] FIG. 66 illustrates a therapeutic cushion system 1700 (also referred to herein as a “cushion system”) that includes a support element 1720 and a riser element 1722 formed as single component. The support element 1720 and the riser element 1722 collectively define a receiving portion 1758 in which a user can place an arm during use of the cushion system 1700. As with the previous embodiment, the cushion system 1700 also includes a first side bolster portion 1782 and a second side bolster portion (not shown in FIG.66) on an opposite side of the support element 1720 that can each be used to help maintain a user in a side

position during use of the cushion system 1700. As with the previous embodiment, the first side bolster portion 1782 and the second side bolster portion (not shown) each include a first top surface portion 1785 and a second top surface portion 1786 disposed at a different angle than the first top surface portion 1785 relative to a bottom surface 1739 of the support element 1720. The first side bolster portion 1782 (and the second side bolster portion) also each include an angled or beveled portion 1781.

[1221] The support element 1720 includes an angled top surface 1737, and can include a concave portion (not shown) at a second end of the support element 1720 as described above for previous embodiments. As with previous embodiments, the support element 1720 can include a cushion member (not shown) that can be formed with, for example, one or more foam materials, and an outer casing 1761 can encase the cushion member, the first side bolster portion 1782 and the second side bolster portion (not shown). The outer casing 1761 can also encase a cushion member (not shown) and pillow insert portion (not shown) of the riser element 1722.

[1222] The cushion systems 1600 and 1700 can each be used in the same or similar manner as described above for previous embodiments of a cushion system. For example, the user can place the cushion system 1600 or 1700 (i.e., the support element 1620, 1720 and the riser element 1622, 1722) on a support surface and the user can position the user's body in a side position (i.e., either a right-side lateral position or a left-side lateral position) and place the user's arm within the receiving portion 1658 or 1758. As described above for previous embodiments, the cushion system 1600 (i.e., the support element 1620 and the riser element 1622 collectively) and the cushion system 1700 (i.e., the support element 1720 and the riser element 1722 collectively) can have a bed size length, or can alternatively have a torso size length. An optional body element (not shown) can also be used in the same or similar manner as described above for previous embodiments.

[1223] FIGS. 67-70 illustrate another embodiment of a cushion system with a side bolster portion. In this embodiment, a therapeutic cushion system 1800 (also referred to herein as a "cushion system") includes a support element 1820 and a riser element 1822 formed as a single component. The support element 1820 and the riser element 1822 collectively define a receiving portion 1858 in which a user can place an arm during use of the cushion system 1800. The cushion system 1800 also includes a side bolster portion 1882 disposed on one side of the support element 1820. The side bolster portion 1882 can be used to help

maintain a user in a right-side position during use of the cushion system 1800. In this embodiment, the side bolster 1882 includes a first top surface portion 1885 and a second top surface portion 1886 disposed at a different angle than the first top surface portion 1885 relative to a bottom surface 1839 of the support element 1820.

[1224] The support element 1820 includes an angled top surface 1837 and a concave portion 1830 at a second end of the support element 1820 as described above for previous embodiments. As with previous embodiments, the support element 1820 can include a cushion member (not shown) that can be formed with, for example, one or more foam materials, and an outer casing 1861 (see, e.g., FIGS. 67 and 70) can encase the cushion member and the side bolster portion 1882. The outer casing 1861 can also encase a cushion member (not shown) and pillow insert portion (not shown) of the riser element 1822. In this embodiment, the side bolster 1882 includes a first top surface portion and a second top surface portion angled at a different angle than the first top surface portion relative to a bottom surface 1839 of the support element 1820.

[1225] The cushion system 1800 can be used in the same or similar manner as described above for previous embodiments of a cushion system. For example, the user can place the cushion system 1800 (i.e., the support element 1820 and the riser element 1822) on a support surface. In this embodiment, the user can position the user's body in a right-side position and place the user's right arm within the open space 1858. An optional body element (not shown) can also be used in the same or similar manner as described above for previous embodiments.

[1226] The cushion system 1800 (i.e., the support element 1820 and the riser element 1822 collectively) has a bed size length. FIGS. 71-74 illustrate a cushion system 1900 (also referred to herein as a "cushion system") that can be configured the same as or similar to the cushion system 1800 but has a torso size length. The cushion system 1900 includes a support element 1920, a riser element 1922, and a side bolster 1982. The support element 1920 and the riser element 1922 are formed as a single component and collectively define a receiving portion 1958 in which a user can place an arm during use of the cushion system 1900. The side bolster portion 1982 is disposed on one side of the support element 1920 and can be used to help maintain a user in a right-side position during use of the cushion system 1900. In this embodiment, the side bolster 1982 includes an angled top surface 1985 that is angled relative to a bottom surface 1939 of the support element 1920. As shown for

example, in FIGS. 71 and 72, the side bolster 1982 extends beyond a tail or foot end of the support element 1920.

[1227] The support element 1920 includes an angled top surface 1937 and a concave portion 1930 at a second end of the support element 1920 as described above for previous embodiments. As with previous embodiments, the support element 1920 can include a cushion member (not shown) that can be formed with, for example, one or more foam materials, and an outer casing 1961 (see, e.g., FIGS. 71 and 74) can encase the cushion member and the side bolster portion 1982. The outer casing 1961 can also encase a cushion member (not shown) and pillow insert portion (not shown) of the riser element 1922.

[1228] The cushion system 1900 can be used in the same or similar manner as described above for previous embodiments of a cushion system. For example, the user can place the cushion system 1900 (i.e., the support element 1920 and the riser element 1922) on a support surface. In this embodiment, the user can position the user's body in a right-side position on the cushion system 1900 and place the user's right arm within the open space 1958. An optional body element (not shown) can also be used in the same or similar manner as described above for previous embodiments.

[1229] Although cushion system 1800 and cushion system 1900 are described above as having a side bolster portion on one side of the cushion system 1800, 1900 such that the user can be positioned on the cushion system 1800, 1900 in a right-side position with the user's right arm within the open space 1858, 1958, in alternative embodiments, the cushion systems 1800 and 1900 can be configured such that the user can be positioned in a left-side position on the cushion system 1800, 1900. For example, the cushion system 1800 and the cushion system 1900 can each alternatively include a side bolster portion on the left side of the cushion system and an open space disposed such that a user can be positioned on the cushion system in a left-side position with the user's left arm within the open space. An example of such an embodiment is illustrated in FIG. 75. As shown in FIG. 75, a therapeutic cushion system 2000 (also referred to herein as a "cushion system") can include a support element 2020 and a riser element 2020 that collectively define a receiving portion 2058 and a side bolster portion 2082. The cushion system 2000 can include features the same as or similar to, and function the same as or similar to, the cushion systems 1800 and 1900.

[1230] FIGS. 76, 77 and 78(A)-78(E) each illustrate a different embodiment of a support element that includes a non-slip feature and that can be included in a cushion system as described herein. The non-slip surface feature(s) can be disposed on a top surface of support element and/or on a bottom surface of a side support member (e.g., 864, 964) or a bolster member (e.g., 1582, 1583). For example, a non-slip surface feature can be disposed on a bottom surface of a side support member (or separate bolster member) and/or on a top surface of the support element on which the side support element is to be disposed. Thus, a non-slip surface feature(s) can also be used, for example, to maintain a side support member (e.g., 864, 964) or a separate bolster member (e.g., 1582, 1583) in a desired position on a support element. A non-slip surface feature(s) can also be used, for example, to maintain a body element in a desired position on a support element and/or to help maintain a user in a desired position on the support element.

[1231] A non-slip feature can include, for example, a patterned tactile treatment used to create a non-slip surface. The patterned treatment can include, for example, ink, rubber, silicone, or other suitable material(s), which can be, for example, digitally printed, screen-printed, sprayed, brushed, ironed on, sewn on, or otherwise applied to at least a portion of the material on the top surface of a support element. The non-slip surface treatment can include, for example, straight lines, curved lines, diagonal lines, various shapes, such as, for example, squares, circles, rectangles, blocks, polygons, ellipses, etc. and/or other ambiguous shapes. In some embodiments, the non-slip surface treatment can include a grooved or grid-like pattern. In some embodiments, the non-slip surface treatment can be applied as a flat or smooth surface, or can be applied such that the non-slip surface is raised with respect to the surface to which it is applied. FIGS. 76, 77 and 78(A)-78(E) illustrate some example patterns and configurations for a non-slip surface, and it should be understood that other patterns and configurations can alternatively be included.

[1232] Each embodiment of a support element described with reference to FIGS. 76, 77 and 78(A)-78(E) can include the same or similar features, and can function the same or similar to, other embodiments of a support element described herein, and therefore certain details are not described with reference to FIGS. 76, 77 and 78(A)-78(E). Further, although not shown with respect to other embodiments of a support element described herein, it should be understood that other embodiments of a support element can include non-slip features as described with respect to FIGS. 76, 77 and 78(A)-78(E).

[1233] FIG. 76 illustrates a support element 2620 that includes two non-slip surface features A disposed on lateral sides of the top surface of the support element 2620, and a non-slip surface feature B disposed on a center portion of the top surface. In this embodiment, the non-slip surface feature A can be used, for example, to help maintain a body element (not shown) in a desired position on the support element 2624. The non-slip surface treatment B can be used, for example, to retain a user of the support element 2524 in a desired position substantially centered on the support element 2624 and also can help prevent or reduce the tendency of the user to slide down an angled top surface of the support element. FIG. 77 illustrates a support element 2720 that includes only two non-slip surface features A disposed on lateral sides of the top surface of the support element 2720. In this embodiment the non-slip surface features A can function in the same manner as described above for the non-slip surface features A of support element 2620. This embodiment also illustrates an example of an applied non-slip pattern. FIGS. 78(A)-78(F) each illustrate a top view of a different embodiment of a support element having various different non-slip surface features.

[1234] FIGS. 79 and 80 illustrate a therapeutic cushion system that includes a side extension element. A side extension element can be coupled to a support element to provide a larger width to support the user's body and/or to support a body element if the user's body is occupying a large portion of the support element. As shown in FIG. 79, a therapeutic cushion system 2800 includes a support element 2820, a riser element 2822 and a side extension element 2887. The support element 2820 and the riser element 2822 can be formed the same as or similar to, and function the same as or similar to, previous embodiments (e.g., support element 220 and riser element 222) described herein and are, therefore, not described in detail with reference to FIGS. 79 and 80.

[1235] The side extension element 2887 includes a first extension member 2888, a second extension member 2889, and a connecting strap 2890 extending between the first extension member 2888 and the second extension member 2889, as shown in FIG. 80. The side extension element 2887 can be fixedly or removably coupled to the support element 2820, as shown in FIG. 79, such that the first extension member 2888 is disposed on a first lateral side of the support element 2820 and the second extension member 2889 is disposed on an opposite second lateral side of the support element 2820.

[1236] The first extension member 2888 and the second extension member 2889 can each be constructed the same as or similar to a support element (e.g., support element 120) as described herein. For example, the first extension member 2888 and the second extension member 2889 can each have an angled top surface (e.g., wedge shape), for example, that substantially matches the angle of the support element 2820. For example, in some embodiments, the first extension member 2888 and the second extension member 2889 can each have a top surface that has an angle between 6 degrees and 30 degrees relative to a bottom surface.

[1237] The first extension member 2888 and the second extension member 2889 can each be a variety of different lengths, widths and/or thicknesses. For example, the first extension member 2888 and the second extension member 2889 can each have a torso length or can each have a bed length as described above for support element 120. The first extension member 2888 and the second extension member 2889 can also each include a cushion member (not shown) disposed within an outer casing 2891.

[1238] The outer casing 2891 can be formed with the same or similar materials as the outer casing 121 described above, and can include a top portion on which the user contacts during use that is formed with a first material, and a bottom portion that contacts the support surface (e.g., top surface of a bed) that is formed with a second material. The top portion (e.g., the top surface) of the outer casing 2891 can be formed with, for example, a four-way stretch material that is highly conformable, such as, for example, cotton/spandex, nylon/spandex, polyester/spandex or blends of any blend of cotton, nylon or polyester combined with spandex, and the bottom portion can be formed with a more robust material, such as, for example, poplin, canvas, gabardine or twill made using any combination of cotton, polyester or nylon, to provide durability.

[1239] The outer casing 2891 can also include an opening (not shown) through which the cushion member can be inserted and can include a fastener such as, for example, a zipper, buttons, snaps, flaps, hook and loop fasteners or other suitable coupling method to close or partially close the opening. The cushion member of the side extension element 2887 can be formed with the same or similar materials as described above for cushion member 123. For example, the cushion member of the side extension element 2887 can be formed with one or more foam materials, such as, for example, polyurethane or rubber latex, and in some embodiments, can include multiple different foam materials each having a different density.

[1240] The side extension element 2887 also includes straps 2892 on each of the first and second extension members 2888 and 2889. The straps 2892 can be formed with, for example, the same or similar material as the straps 226 of riser element 222 described above. Each strap 2892 can include button holes 2893 (only shown on extension member 2888 in FIG. 80) that can be used to removably couple the side extension element 2887 to buttons (not shown in FIGS. 79 and 80) on the support element 2820 (e.g., similar to the buttons 228 on support element 220 described above). For example, in some embodiments, the side extension element 2887 can be coupled to the support element 2820 using the same buttons as used to couple the riser element 2822 to the support element 2820. In some embodiments, a different set of buttons can be used. In alternative embodiments, other coupling methods can be used to couple the straps 2892 to the support element 2820, such as, for example, hook and loop fasteners, snaps, strings or ties, zippers, or any other suitable coupling method.

[1241] The connecting strap 2890 can be formed with, for example, an elastic material, such that the connecting straps 2890 can hold each of the first and second extension members 2888 and 2889 substantially tight against the support element 2820. Each of the first and second extension members 2888 and 2889 can also include a non-slip surface treatment 2894 (only shown on extension member 2889 in FIG. 80) as described above for previous embodiments of a support element.

[1242] FIGS. 81-95 illustrate another embodiment of a therapeutic cushion system. A therapeutic cushion system 2900 (also referred to herein as a “cushion system”) includes a base support 2910, a support pillow member 2984 and an optional body element 2924. The base support 2910 can be constructed the same as or similar to and can function the same as or similar to, the support elements (e.g., 120, 220, etc.) described above for previous embodiments. The support pillow member 2984 can be constructed the same as or similar to, and can function the same as or similar to, the riser elements (e.g., 122, 222, etc.) described above for previous embodiments. For example, the same or similar materials can be used to construct the base support 2910 and the support pillow member 2984 as described above for previous embodiments of a support element and riser element, respectively. Therefore, some details with respect to the materials and construction of the base support 2910 and/or the support pillow member 2984 may not be described below. The body element 2924 can be formed the same as or similar to, and function the same as or similar to

the body elements (e.g., 124, etc.) described above for previous embodiments. For example, the body element 2910 can be formed the same as or similar to the body element 624 described with respect to FIG. 29. Thus, some details with respect to the body element 2924 are not described below.

[1243] The base support 2910 includes a support element portion 2920 and an encasement portion 2996, and can be formed with one or more components. For example, in some embodiments, the base support 2910 is formed as a single component, and in other embodiments, the base support 2910 can be formed with multiple components coupled together to form a single component. For example, multiple components can be adhesively bonded together to form a single component for the base support 2910.

[1244] The base support 2910 can include an interior cushion member (not shown) and an outer casing 2961 that can encase the cushion member of the base support 2910. The outer casing 2961 can be formed with one or more materials as described above, for example, for outer casing 121 of support element 120. The interior cushion member can be formed with, for example, one or more foam materials as described above for previous embodiments. The support element portion 2920 and the encasement portion 2996 of the base support 2910 can be formed integrally as a single component or can be separate components coupled together with, for example, an adhesive. Further, each of the support element portion 2920 and the encasement portion 2996 can be formed as a single component or with multiple components (e.g. foam components) that are coupled (e.g., bonded) together. In some embodiments, the cushion member of the support element portion 2920 can be formed with the same foam material(s) as the foam material(s) used to form the encasement portion 2996. In some embodiments, different foam material(s) are used for the cushion member of the support element portion 2920 and the cushion member of the encasement portion 2996.

[1245] The base support 2910 defines an interior region 2995 between the encasement portion 2996 and the support element portion 2920 (as shown, for example, in FIGS. 90-95), in which the support pillow member 2984 can be disposed. When the support pillow member 2984 is disposed within the interior region 2995, a receiving portion 2958 is defined by the base support 2910 and the support pillow member 2984 on each side of the support pillow member 2984. As with previous embodiments, the receiving portions 2958 can be

used as a relief area for the user to place a portion of a user's arm and/or shoulder when using the cushion system 2900.

[1246] The base support 2910 also defines a lower arm/elbow relief cavity 2997 (also referred to herein as "cavity" or "relief cavity") on each side of the base support 2910 that can receive a portion of a user's arm and/or hand therethrough. For example, the relief cavity(ies) 2997 is in communication with the interior region 2995 (see, e.g., FIG. 92), such that when a user places an arm within the interior region 2995, the user can extend a hand and/or a portion of the user's arm out through one of the relief cavities 2997. Thus, the relief cavity(ies) 2997 can be used to allow increased movement of the user's hand and/or arm while disposed within the receiving portion 2958, and can also act as a ventilation passageway. The base support 2910 can also include an optional pocket 2998 and/or optional transport handles 2999 that can be coupled to the outer casing 2961. For example, in some embodiments, the pocket 2998 and/or transport handles 2999 can be sewn to the outer casing 2961. The pocket 2998 can be formed with the same or different material(s) as the outer casing 2961 and can be used, for example, to place an object such as a cell phone. The handles 2999 can also be formed with the same or different material(s) as the outer casing 2961 and can be used to help transport the base support 2910 to a desired location.

[1247] The support element portion 2920 of the base support 2910 can have a variety of different shapes and/or sizes. For example, as shown in FIGS. 81, 82, 87, 94 and 95, the support element portion 2920 can have a wedge shape. Specifically, the support element portion 2920 includes a top surface 2937 that is angled relative to a bottom surface 2939 (see, e.g., FIGS. 83, 84 and 87) between a first end portion 2915 and a second end portion 2916 (see, e.g., FIGS. 87, 90 and 91). Said another way, the second end portion 2916 has a height greater than the first end portion 2915. In some embodiments, the angled top surface 2937 can be disposed, for example, at an angle between 6 degrees and 30 degrees relative to the bottom surface 2939 of the support element portion 2920. The support element portion 2920 also includes a concave portion 2930, and beveled or angled corners 2933 (see, e.g., FIGS. 90 and 91) on the second end portion 2916 of the support element portion 2920 that can accommodate additional ergonomic arm and elbow placement during use of the cushion system 2900.

[1248] The encasement portion 2996 extends from the support element portion 2920 and can be a variety of shapes and/or sizes. For example, in this embodiment, the encasement

portion 2996 has a curved shape, as viewed for example, in a top view, as shown, in FIGS. 90 and 91. In other embodiments it can have a different shape, such as, for example, square, rectangular, oval, trapezoidal, or a curved shape with a different radius than the encasement portion 2996 shown in FIGS. 90 and 91. The encasement portion 2996 has a top surface 2917 and a bottom surface 2918. In some embodiments, the top surface 2917 is substantially parallel to the bottom surface 2918. In some embodiments, the top surface 2917 and the bottom surface 2918 are disposed at an angle relative to each other. In some embodiments, the top surface 2917 and/or the bottom surface 2918 may be angled relative to a support surface on which the cushion system 2900 is disposed.

[1249] The support pillow member 2984 can include a pillow insert (not shown) that can be disposed within an outer casing 2927 (see, e.g., FIGS. 90 and 91). For example, the outer casing 2927 can include an opening through which the pillow insert can be inserted, and can include a fastener such as, for example, a zipper, buttons, snaps, flaps, hook and loop fasteners or other suitable coupling method to close or partially close the opening. The outer casing 2927 can be formed with the same or similar materials as described above, for example, for the outer casing 127. For example, in some embodiments, the outer casing 2927 can include a first portion formed with a four-way stretch material and a second portion formed with a more robust material. For example, in some embodiments, a top surface of the outer casing 2927 of the support pillow member 2984 can be formed with the four-way stretch material, and a bottom surface of the outer casing 2927 of the support pillow member 2984 can be formed with a more robust material.

[1250] The pillow insert (that is disposed within the outer casing 2927) can include an inner casing (not shown) that can contain a filler material (not shown) therein, as described above, for example, for pillow inserts 125 and 225. The filler material can be, for example, a clustered polyester fiber material, such as, for example, any combination of polyester fibers, clustered polyester fiber, down alternative made from synthetic fibers, polystyrene beads/pellets, shredded foam, or down feathers. The inner casing of the pillow insert can also be formed with a four-way stretch material as described above for pillow insert 125. In some embodiments, the inner casing of the pillow insert can also include an opening through which the filler material can be inserted, and can include a fastener such as, for example, a zipper, buttons, snaps, or other suitable coupling method to close or partially close the opening. In alternative embodiments, the inner casing may not include such an opening.

For example, after the filler material has been inserted into the inner casing, the inner casing can be closed with, for example, stitching.

[1251] The four-way stretch material of the outer casing 2927 of the support pillow member 2984 described above, in conjunction with the pillow insert having an inner casing formed with the four-way stretch material and having a clustered polyester fiber filler material can allow the support pillow member 2984 to be malleable and shape-retaining. For example, in such an embodiment, the user can conform the support pillow member 2984 to a desired thickness and/or shape for that user's needs and preference. For example, the user can conform or adjust the support pillow member 2984 to form cavities or to otherwise fit or conform to the user's head, face, ear, shoulder, arm, etc. The conformed shape can be maintained for an extended time period and/or until the user disperses the filler material of the pillow insert by, for example, shaking or fluffing the support pillow member 2984.

[1252] As described above, the support pillow member 2984 can be placed within the interior region 2995 defined by the base support 2910, as shown for example, in FIGS. 93-95. The encasement portion 2996 can allow for easier setup of the cushion system 2900, and increased user comfort, adjustability and fitment to the cushion system 2900. With the support pillow member 2984 disposed within the interior region 2995, a user's arm can easily enter and exit the receiving portion 2958 and relief cavity 2997. Further, when disposed within the interior region 2995, the support pillow member 2984 is not restricted by specific attachment points, but rather is free to move on its own within the interior region 2995. For example, as shown in FIG. 93, the support pillow member 2984 can move side to side in the direction of Arrows A, and/or up and down in the direction of Arrows B.

[1253] The curved encasement portion 2996 extending from the support element portion 2920 can help provide overall stability to the cushion system 2900. In some embodiments, the encasement portion 2995 can be, for example, about 3 inches wide in a top view. The base support 2910 can have a variety of different lengths and widths. For example, in some embodiments, the overall width of the base support 2910 can be, for example, in the range of 24-39 inches. In one example, the overall width of the base support 2910 is about 30 inches. In some embodiments, the base support 2910 can have a length that is a torso size as described above, for example, for cushion systems 200 and 700.

[1254] In use, the base support 2910 can be placed on a support surface, such as, for example, a bed, box spring, bed foundation or floor, for use by a user in the same or similar manner as described above for previous embodiments. The support pillow member 2984 can be placed within the interior region 2995 as shown, for example, in FIGS. 94 and 95. The body element 2924 can then be positioned on the top surface of the base support 2910 and/or support pillow member 2984 as shown, for example, in FIGS.81-83 and 95. A user can be positioned on the cushion system 2900 as described above for previous embodiments, in an inclined right-side lateral decubitus (RLD) or an inclined left-side lateral decubitus position (LLD), depending on the particular needs of the user, with the user's right or left arm disposed within the receiving portion 2958 and optionally through the relief cavity 2997. For example, the user can be disposed on the base support 2910 of the therapeutic cushion system 2900 having an angled top surface of between 6 degrees and 30 degrees. In such an embodiment, the user can be positioned on the base support 2910 at an angle between about 5 and 20 degrees depending on factors, such as, for example, the density and/or deflection properties of the base support 2910, and/or the weight of the user. In some cases, the user of the therapeutic cushion system 2900 can be maintained in the inclined RLD position or LLD position for a sufficient time period to treat symptoms associated with GERD. In some embodiments, the time period is at least one hour. In some embodiments, the time period is 6 hours. In some embodiments, the maintaining includes positioning a body element (e.g., body element 2924) of the therapeutic cushion system 2900 proximate the base support 2910 and optionally proximate the support pillow member 2996 of the therapeutic cushion system 2900.

[1255] FIGS. 96-113 illustrate another embodiment of a therapeutic cushion system. A therapeutic cushion system 3000 (also referred to herein as a "cushion system") includes a base support 3010, a support pillow member 3084 and an optional body element 3024. Some features of the base support 3010 can be constructed the same as or similar to, and can function the same as or similar to, the support elements (e.g., 120, 220, etc.) described above for previous embodiments. For example, the same or similar materials can be used to construct the base support 3010 as described above for previous embodiments of a support element. Therefore, some details with respect to the materials and construction of the base support 3010 may not be described below.

[1256] As with the previous embodiment (e.g., 2910) the base support 3010 includes a support element portion 3020 and an encasement portion 3096, and can be formed with one or more components. For example, in some embodiments, the base support 3010 is formed as a single component, and in other embodiments, the base support 3010 can be formed with multiple components coupled together to form a single component. For example, multiple components can be adhesively bonded together to form a single component for the base support 3010.

[1257] The base support 3010 can include an interior cushion member (not shown) and an outer casing 3061 that can encase the cushion member of the base support 3010. The interior cushion member can be formed with, for example, one or more foam materials as described above for previous embodiments. The support element portion 3020 and the encasement portion 3096 of the base support 3010 can be formed integrally as a single component or can be separate components coupled together with, for example, an adhesive. Further, each of the support element portion 3020 and the encasement portion 3096 can be formed as a single component or with multiple components (e.g. foam components) that are coupled (e.g., bonded) together. In some embodiments, the cushion member of the support element portion 3020 can be formed with the same foam material(s) as the foam material(s) used to form the encasement portion 3096. In some embodiments, different foam material(s) are used for the cushion member of the support element portion 3020 and the cushion member of the encasement portion 3096.

[1258] In this embodiment, the support pillow member 3084 is formed with a foam material and is coupled to or formed integrally or monolithically with the encasement portion 3096 and/or the support portion 3020 of the base support 3010. In some embodiments, the support pillow member 3084 can be fixedly coupled to the base support 3010. In some embodiments, the support pillow member 3084 is formed with the same foam material as the foam material used to form the support element portion 3020 and/or the encasement portion 3096 of the base support 3010. In some embodiments, the support pillow member 3084 is formed with a different foam material as the foam material used to form the support element portion 3020 and/or the encasement portion 3096 of the base support 3010. In some embodiments, the support pillow member 3084 is a separate component that is adhesively or otherwise coupled to the encasement portion 3096 (see, e.g., FIG. 108 illustrating the support pillow member 3084 coupled to the encasement portion

3096). The support pillow member 3084 can include a top surface 3008 that is substantially flush or aligned with a top surface 3017 (see, e.g., FIG. 102) of the encasement portion 3096 and a bottom surface 3009 that is substantially flush or aligned with a bottom surface 3018 (see, e.g., FIG. 102) of the encasement portion 3096 and/or the bottom surface 3039 of the support element portion 3020 (see, e.g., FIG. 103). The support pillow member 3084 can also include a shoulder relief region or cut-out 3057. The shoulder relief region 3057 can provide additional relief to a user's arm and or shoulder.

[1259] The support pillow member 3084 can be disposed within or encased within the outer casing 3061 together with the interior cushion member (not shown) of the base support 3010. The outer casing 3061 can be formed with one or more materials as described above, for example, for outer casing 121 of support element 120. In some embodiments, the outer casing 3061 can be formed with a four-way stretch material. In some embodiments, the outer casing 3061 can be constructed of a two-way stretch material, such as, for example, jersey or interlock, or a velour fabric. In some embodiments, the outer casing 3061 can be formed with more than one material. For example, in some embodiments, a top portion of the outer casing 3061 can be formed with a two-way or a four-way stretch material, and a bottom portion of the outer casing 3061 can be formed with a more robust material. In some embodiments, the outer casing 3061 can include a two-way or four-way stretch material on an outer surface with an impermeable undercover or sub-layer (i.e., an inside surface) to protect the interior cushion member from liquid absorption.

[1260] The outer casing 3061 can include an opening through which the support pillow member 3084 and base support 3010 can be inserted, and can include a fastener such as, for example, a zipper, buttons, snaps, flaps, hook and loop fasteners or other suitable coupling method to close or partially close the opening. In this embodiment a zipper 3007 is used to open and close the outer casing 3061 as shown, for example, in FIGS. 99, 100 and 105. As shown in FIGS. 98-100 and 105, the zipper 3007 wraps around the encasement portion 3096 at the front or head end of the base support 3010, around the sides of a portion of the support element portion 3020 (see, e.g., FIGS. 98 and 100) and down across the bottom surface 3039 of the support element portion 3020 as shown in FIG. 99.

[1261] In this embodiment, the base support 3010 (i.e., the support portion 3020 and the encasement portion 3096) and the support pillow member 3084 collectively define an interior region 3095 (as shown, for example, in FIGS. 106-107). The interior region 3095

includes a receiving portion 3058 on each side of the support pillow member 3084 that are in fluid communication with each other through a center region 3002 between the support pillow member 3084 and the support element portion 3020. In some embodiments, the interior region 3095 may not include all or part of the center region 3002. For example, in an alternative embodiment, the support pillow member 3084 can be connected to or formed integrally with the support element portion 3020 at the center region. As with previous embodiments, the receiving portions 3058 can be used as a relief area for the user to place a portion of a user's arm and/or shoulder when using the cushion system 3000. In this embodiment, the receiving portions 3058 can include an increased volume for greater elbow and arm movement and increased placement or positioning options for a user.

[1262] As with previous embodiments, the base support 3010 also defines a lower arm/elbow relief cavity 3097 (also referred to herein as "cavity" or "relief cavity") on each side of the base support 3010 that can receive a portion of a user's arm and/or hand therethrough. For example, the relief cavity(ies) 3097 is in communication with the interior region 3095 such that when a user places an arm within the interior region 3095 (i.e., a receiving portion 3058), the user can extend a hand and/or a portion of the user's arm out through one of the relief cavities 3097. In this embodiment, the relief cavity can be larger than in the previous embodiment in both height and length, providing further arm and elbow movement options and increasing ventilation within the receiving portions 3058 and relief cavities 3097. The relief cavities 3097 can also extend or wrap part-way around to the front or head end of the base support 3010, as shown, for example, in FIGS. 100, 102 and 103. Although not shown, the base support 3010 can also include an optional pocket and/or optional transport handles that can be coupled to the outer casing 3061 as described above for the previous embodiment.

[1263] The base support 3010 can have a variety of different lengths and widths. For example, in some embodiments, the overall width of the base support 3010 can be, for example, in the range of 24-39 inches. In one example, the overall width of the base support 3010 is about 30 inches. In some embodiments, the base support 3010 can have a length that is a torso size as described above, for example, for cushion systems 200 and 700.

[1264] The support element portion 3020 of the base support 3010 can have a variety of different shapes and/or sizes. For example, as shown in FIGS. 98 and 105, the support element portion 3020 can have a wedge shape. Specifically, the support element portion

3020 includes a top surface 3037 that is angled relative to a bottom surface 3039 (see, e.g., FIGS. 98 and 105) between a first end portion 3015 and a second end portion 3016 (see, e.g., FIG. 105). Said another way, the second end portion 3016 has a height greater than the first end portion 3015. In some embodiments, the angled top surface 3037 can be disposed, for example, at an angle between 6 degrees and 30 degrees relative to the bottom surface 3039 of the support element portion 3020. The support element portion 3020 also includes a concave portion 3030 (see, e.g., FIGS. 102, 104 and 106) that can be used to relieve pressure in the user's downside axilla when the user is lying in a lateral decubitus position on the cushion system 3000, and beveled or angled corners 3033 (see, e.g., FIGS. 106 and 107) on the second end portion 3016 of the support element portion 3020 that can accommodate additional ergonomic arm and elbow placement during use of the cushion system 3000.

[1265] The encasement portion 3096 extends from the support element portion 3020 and can be a variety of shapes and/or sizes. For example, in this embodiment, the encasement portion 3096 has a curved shape, as viewed for example, in a top view, as shown, in FIGS. 97 and 106. In other embodiments it can have a different shape, such as, for example, square, rectangular, oval, trapezoidal, or a curved shape with a different radius than the encasement portion 3096 shown in FIGS. 97 and 106. In some embodiments, the top surface 3017 of the encasement portion 3096 is substantially parallel to the bottom surface 3018 of the encasement portion 3096 (see, e.g., FIG. 105). In some embodiments, the top surface 3017 and the bottom surface 3018 can be disposed at an angle relative to each other. In some embodiments, the top surface 3017 and/or the bottom surface 3018 may be angled relative to a support surface on which the cushion system 3000 is disposed. In some embodiments, the encasement portion 3096 can be, for example, about 3 inches wide in a top view.

[1266] As with the previous embodiment, the curved encasement portion 3096 extending from the support element portion 3020 can help provide overall stability to the cushion system 3000. For example, the encasement portion 3096 can allow the user's arm (or hand) to be stabilized or otherwise elevated in order to reduce or prevent edema that can result from a user's arm dangling loosely into the relief cavity 3097. The encasement portion 3096 can thus provide for an arm/hand cradle that can help control arm placement and can help improve user comfort and stability, as well as improving sleep and rest.

[1267] In this embodiment, the body element 3024 includes an arc portion 3041 that has a substantially 180 degree curvature at a cephalad end portion, a first arm 3047 and second arm 3048 each extending from the arc portion 3041 in a caudad direction, as shown, for example, in FIGS. 109-111. In this embodiment, the first arm 3047 has a length that is shorter than a length of the second arm 3048. For example, in some embodiments, the first arm 3047 can have a length, for example, that is in the range of 25% to 50% shorter than a length of the second arm 3048. The second arm 3048 can include a slightly tapered end portion 3003 (e.g., having a narrower thickness) for increased comfort when placing the second arm 3048 in-between the knees of a user. The body element 3024 can be used with the base support 3010 in the same or similar manner as described above for previous embodiments. Optionally, in some embodiments, the body element 3024 can be used independently of the base support 3010.

[1268] In this embodiment, the body element 3024 includes a foam pillow insert member (not shown) disposed within a sleeve or cover member 3031. The sleeve member 3031 can include an opening or openings through which the foam pillow insert can be inserted, and can include a fastener such as, for example, a zipper, buttons, snaps, or other suitable coupling method to close or partially close the opening(s). The foam pillow insert can be formed with one or more foam materials and can be formed with the same or different foam material as used to construct the support pillow member 3084 and/or the base support 3010. In some embodiments, the foam pillow insert can include optional bend relief cuts (not shown) at select locations to allow the body element 3024 (see, e.g., FIG. 117 described below).

[1269] The sleeve member 3031 encasing the foam pillow insert of the body element 3024 can be formed with, for example, a four-way stretch material as described above for other embodiments. In some embodiments, the sleeve member 3031 can be constructed of a two-way stretch material, such as, for example, jersey or interlock, or a velour fabric. A two-way stretch material, such as, velour can provide several beneficial properties, including, for example, comfort and wash-ability. Velour fabric can also exhibit properties similar to Velcro. For example, when the outer casing 3061 of the base support 3010 and the sleeve member 3031 of the body element 3024 are both formed with a velour material, the base support 3010 and the body element 3024 can “stick” together, enhancing the maintenance of the user’s side position. In some embodiments, the sleeve member 3031 can

be formed with more than one material. For example, in some embodiments, the sleeve member 3031 can include a top portion formed with a two-way or a four-way stretch material, and a bottom portion formed with a more robust material. In some embodiments, the sleeve member 3031 can include a two-way or four-way stretch material on an outer surface and an impermeable sub-layer or undercover (i.e., an inside surface) to protect the foam insert member from liquid absorption. The tubular shape of the sleeve member 3031 can be formed, for example, in the same or similar manner as described above for previous embodiments.

[1270] As shown, for example, in FIGS. 109-111, the body element 3024 also includes lateral or side support bolsters 3060 on a top surface of the body element 3024. For example, the foam pillow insert member can be constructed to include the side support bolsters 3060. The side support bolsters 3060 can help maintain the user in a lateral or side position on the cushion system 3000. The side support bolsters 3060 each have a top surface portion 3004 that is angled relative to a bottom surface of the body element 3024, a head end angled surface portion 3005 and a leg end angled surface portion 3006 as shown, for example, in FIG. 111. In some embodiments, relative to a support surface (e.g., a bed surface) on which the base support 3010 is placed, a height of the side support bolsters 3060 near where a user's chest may rest (e.g., at the highest point on the bolster 3060) can be about 6 inches, a portion of the base support 3010 near where a user's head may rest can be about 3 inches, and a portion of the base support 3010 near where a user's knees may rest can be about 4 inches.

[1271] In use, the base support 3010 can be placed on a support surface, such as, for example, a bed, box spring, bed foundation or floor, for use by a user in the same or similar manner as described above for previous embodiments. The body element 3024 can be positioned on the top surface of the base support 3010 (i.e., at least on the support element portion 3020) as shown, for example, in FIGS. 96-101, 112 and 113. A user can be positioned on the cushion system 3000 as described above for previous embodiments, in an inclined right-side lateral decubitus (RLD) or an inclined left-side lateral decubitus position (LLD), depending on the particular needs of the user, with the user's right or left arm disposed within the receiving portion 3058 and optionally through the relief cavity 3097. For example, the user can be disposed on the base support 3010 of the therapeutic cushion system 3000 and because of the angled top surface of the support element portion 3020, the

user can be positioned at an angle between about 5 and 20 degrees depending on factors, such as, for example, the density and/or deflection properties of the base support 3010, and/or the weight of the user. In some cases, the user of the therapeutic cushion system 3000 can be maintained in the inclined RLD position or LLD position for a sufficient time period to treat symptoms associated with GERD. In some embodiments, the time period is at least one hour. In some embodiments, the time period is 6 hours.

[1272] As shown in FIGS. 112 and 113 (at location A), a portion of the user's arm (and/or hand) can rest upon the encasement portion 3096 to help stabilize or otherwise maintain the user's arm/hand elevated, which as described above, can help reduce or prevent edema. The encasement portion 3096 can thus provide for an arm/hand cradle that can help control arm placement and can help improve user comfort and stability, as well as improving sleep and rest.

[1273] FIGS. 114-117 illustrate another embodiment of a body element 3124 that can be used in any of the cushion systems described herein. The body element 3124 can be constructed the same as or similar to and function the same as or similar to the body element 3024. Therefore, certain features of the body element 3124 are not described below, and it should be understood that for those features not discussed, they can be the same as or similar to those similar features of body element 3024. In this embodiment, the body element 3124 includes an arc portion 3141, a first arm 3147 and second arm 3148 each extending from the arc portion 3141 in a caudad direction. The body element 3124 can be used with the base support 3010 (or any other cushion system described herein) in the same or similar manner as described above for previous embodiments. The body element 3124 can also be used independently of the base support 3010.

[1274] In this embodiment, the body element 3124 includes a foam pillow insert member (not shown) disposed within a sleeve or cover member 3131 that can each be constructed the same as or similar to, and function the same as or similar to, the foam pillow insert and sleeve member 3031, respectively, described above for body element 3024. As shown in FIGS. 114-116, the body element 3124 includes lateral or side support bolsters 3160 on a top surface of the body element 3124 the same as the lateral support bolsters 3060 described above. In this embodiment, the body element 3124 also includes a neck support portion 3162. The neck support portion 3162 in this embodiment is substantially arc shaped as viewed in a top view of FIG. 114. In some embodiments, the neck support portion 3162 can

be contoured. In some embodiments, the foam pillow insert can include optional bend relief cuts (not shown) at select locations to allow the body element 3124 to bend at, for example, bend locations B, as shown, in FIG. 117.

[1275] FIGS. 118-120 illustrate another embodiment of a body element 3224 that can be used in any of the cushion systems described herein. The body element 3224 can be constructed the same as or similar to, and function the same as or similar to, the body element 3024. Therefore, certain features of the body element 3224 are not described below, and it should be understood that for those features not discussed, they can be the same as or similar to those similar features of body element 3024. In this embodiment, the body element 3224 includes an arc portion 3241, a first arm 3247 and second arm 3148 each extending from the arc portion 3241 in a caudad direction. The body element 3224 can be used with the base support 3010 (or any other cushion system described herein) in the same or similar manner as described above for previous embodiments. The body element 3224 can also be used independently of the base support 3010.

[1276] In this embodiment, the body element 3224 includes a foam pillow insert member (not shown) disposed within a sleeve or cover member 3231 that can each be constructed the same as or similar to, and function the same as or similar to, the foam pillow insert and sleeve member 3031, respectively, described above for body element 3024. As shown, in FIGS. 118-120, the body element 3224 includes lateral or side support bolsters 3260 on a top surface of the body element 3224 the same as the lateral support bolsters 3060 described above. The body element 3224 also includes a neck support portion 3262. In this embodiment, the neck support portion 3262 is a raised portion that extends across a width of the body element 3224 as best shown in FIG. 118. In some embodiments, the raised portion of the neck support portion 3262 can be contoured.

[1277] The use of a foam material for the support pillow member 3084 and/or the body elements 3024, 3124, 3224 (i.e., the insert pillow member of the body elements 3024, 3124, 3224) can provide a variety of benefits. For example, foam material can be durable, can retain shape over time and use, and can be resistant to flattening or losing loft, therefore, in some cases can greatly increase longevity of the support pillow member 3084 and/or body elements 3024, 3124, 3224. Foam materials can also be more consistent in shape and size, and therefore can provide less variance in potential comfort to a user. An all foam pillow can also reduce user maintenance, such as for example, shaking or fluffing of the pillow.

Foam can also be more supportive, and therefore, more resistant to undesired lateral user movements. This can increase a user's ability to maintain a side-sleeping position. In some cases, the use of foam to form the support pillow member 3084 and/or the body elements 3024, 3124, 3224 can also be easier to manufacture, require less worker cycle time, provide more repeatable and reproducible operations, and/or remove worker subjectivity like in fiber-filling processes. Packaging and shipping of foam products can also provide for the product to be non-destructively compressed.

[1278] FIGS. 121-123 illustrate the use of the base support 3010 of cushion system 3000 with body element 3124. As shown in FIG. 121, the base support 3010 can be placed on a support surface, such as, for example, a bed, box spring, bed foundation or floor, for use by a user in the same or similar manner as described above for previous embodiments. The body element 3124 can be positioned on the top surface of the base support 3010 as shown, for example, in FIGS. 121-122. A user can be positioned on the cushion system 3000 as described above for previous embodiments, in an inclined right-side lateral decubitus (RLD) or an inclined left-side lateral decubitus position (LLD), depending on the particular needs of the user, with the user's right or left arm disposed within the receiving portion 3058 and optionally through the relief cavity 3097 as shown in FIG. 123. Also shown in FIG. 123, the user can place their head on the arc portion of the body element 3124 with the user's neck supported on the neck support portion 3162, and the arm 3148 of the body element 3124 can be positioned between the user's legs.

[1279] In alternative embodiments, the support pillow member (e.g., 3084) can be formed with a foam material and be a separate component that can be placed within an interior region defined between the encasement portion and the support element portion of the base support, similar to the support pillow member 2984. In other words, the support pillow member is not fixedly attached or formed integrally with the encasement portion or support element portion. In such an embodiment, the support pillow member can have a separate outer casing that can be formed the same as or similar to, for example, the outer casing 2927, or other outer casings and cover members described herein.

[1280] In some embodiments, the therapeutic cushion systems described herein can be provided as a kit that can include any combination or sub-combination of the various components of a cushion system described herein. For example, in some embodiments, a kit can include one or more support elements, one or more riser elements and/or one or more

body elements. In some embodiments, a kit can include one or more base supports, one or more support pillow member and/or one or more body elements. In some embodiments, a kit can include one or more base supports and/or one or more body elements. In some embodiments, a kit can include multiple cushion members that can be selectively assembled into a support element and/or multiple riser cushion members that can be selectively assembled into a riser element as described above for example, with respect to cushion systems 1300 and 1400. In some embodiments, a kit can also include separate side support members (e.g., 864, 964) and/or side bolster members (e.g., 1582, 1682, 1782, 1982, 2082).

[1281] As described above, the therapeutic cushion systems described herein can be used in the treatment of symptoms associated with GERD and/or other digestive disorders and/or other medical conditions or ailments as described herein. Trial studies have been conducted to evaluate the effects of using a therapeutic cushion system as described herein to treat a patient with symptoms of GERD. The results of two such trial studies described below confirm the benefits of using such a therapeutic cushion system to treat symptoms of GERD.

EXAMPLE TRIAL STUDY 1:

[1282] A randomized controlled trial evaluating a sleep device (SD) was performed. See Erik Person, MD, MS, et al., "A Novel Sleep Assist Device Prevents Gastroesophageal Reflux: A Randomized Controlled Trial," *The American Journal of Gastroenterology*, 108:S1-S36, October 2013. The SD used in the study consisted of a two-piece inclined base and a body pillow distributed under the Medcline™ mark by Amenity Health, Inc., of San Diego, California, the assignee of the present application. The SD used in the study maintains a patient in a lateral position while elevating the head and torso and is substantially the same as or similar to, for example, the therapeutic cushion system 200 described herein. It was hypothesized that sleeping in a semi-fixed position on the left side with the head and torso elevated would significantly reduce recumbent gastroesophageal reflux (GER).

[1283] The study involved a single institution, randomized controlled trial involving 20 healthy volunteers, each subject having 4 impedance-pH tests 6 hours in length. After placement of a reflux probe, the subjects returned home and ate a standardized meal (1350 kcal, 58g fat). Each subject then lay down in one of 4 randomly assigned positions: SD right side down (SD-R), SD left side down (SD-L), standard wedge any position (W), and flat any

position (F). Note that the SD-R and SD-L included use of the SD (described above) with volunteers positioned with their right side down and left side down respectively. A wireless position monitor documented position of the volunteers during each study. Number of reflux episodes (RE) and esophageal acid exposure (EAE) was blindly calculated for 6 hour periods. Position monitor data was used to compare assigned position to actual position.

[1284] FIGS. 124 and 125 illustrate the results of the above study. FIG. 124 is a graph illustrating a 6 hour mean esophageal acid exposure (EAE) by position, where the SD-L exhibited significantly less EAE than any other position. FIG. 125 is a graph illustrating a 6 hour mean number of reflux episodes (RE) by position, where SD-L exhibited significantly less reflux episodes than SD-R. In the graphs, SD-L is sleeper device left side down, SD-R is sleeper device right side down, * = $p < .05$, ** = $p < .01$, and *** = $p < .001$.

[1285] The results of the study indicated that significantly less EAE over 6 hours occurred sleeping SD-L compared to sleeping W (mean 0.46% v. 3.59%, $p < .01$), SD-R (mean 0.46% v. 4.59%, $p < .001$), and F (mean 0.46% v. 3.46%, $p < .05$). RE over 6 hours were significantly less SD-L than SD-R (mean 5.55 vs. 13.23, $p < .05$). Patients assigned to SD-L on average spent 83% of the first 2 hours and 61% of the 6 hours in the assigned position. Those assigned to SD-R spent 72% of the first 2 hours and 53% of the 6 hours in the assigned position. Over 6 hours, patients sleeping on W and F averaged significantly more time supine than R or L ($p < .05$).

[1286] The results of the study indicate that the sleep device SD maintains recumbent horizontal position effectively. Lying left side down dramatically reduces recumbent esophageal acid exposure. As in previous studies, right side down position gives the worst results, even with aid of the sleep device.

EXAMPLE TRIAL STUDY 2:

[1287] A second study evaluating a sleep positioning device (SPD) has also been performed. See Sanath Allampati MD, et al., "Use of a Sleep Positioning Device Significantly Improves Nocturnal Gastroesophageal Reflux Symptoms," 2014. The SPD consisted of a two-component incline base (9 inches in height) and a lateral positioner body pillow as compared to a traditional bed wedge. This study showed a decrease in nocturnal GERD (acid exposure and reflux episodes) in healthy volunteers who slept using the SPD. This SPD, also distributed by the assignee of the present application under the Medcline™

mark, places and maintains users in an inclined left-lateral decubitus (I-LLD) sleeping position. The SPD used in the study was substantially the same as or similar to, for example, the therapeutic cushion system 200 described herein. The purpose of this study was to determine if the use of this SPD decreases nocturnal symptoms in patients diagnosed with GERD, as well as to assess its effectiveness in decreasing the morning impact of nocturnal GERD and to address patient concerns about nocturnal GERD.

[1288] The study included a single institution prospective trial involving patients on proton pump inhibitors (PPIs) with continued frequent moderate to severe nocturnal heartburn and regurgitation. Patients completed the Nocturnal GERD Symptom Severity and Impact Questionnaire (N-GSSIQ) at enrollment. The N-GSSIQ is a validated questionnaire comprised of three parts (Nocturnal GERD Symptoms, Morning Impact of GERD, and Concern about Nocturnal GERD) with a total possible score of 95. Patients were then instructed to sleep on the Medcline™ SPD for two weeks for at least 6 hours per night. Patients were also instructed to initiate sleep in the I-LLD position, though their positioning throughout the night was not tracked. At the end of the two week trial, patients repeated the N-GSSIQ. All analyses were performed using SAS (version 9.2, The SAS Institute, Cary, NC) and R (version 3.0.3, The R Foundation for Statistical Computing, Vienna, Austria) which were used to construct plots on FIGS. 123-126.

[1289] The results are illustrated in FIGS. 126-129, which illustrate N-GSSIQ before and after use of the Medcline™ SPD. A total of 9 patients (4 female and 5 male, age 59.9 ± 5.4 years, BMI 29.4 ± 4.3) were recruited from an outpatient gastroenterology clinic. One patient was not able to be contacted to complete the N-GSSIQ after the two week period using the SPD. Significant improvements were seen in all N-GSSIQ pre- vs post scores: Total Score (mean 54.3 vs. 15.4, $p < 0.001$), Nocturnal GERD (mean 35.1 vs. 8.1, $p < 0.001$), Morning Impact of Nocturnal GERD (mean 4.9 vs. 1.6, $p = 0.015$), and Concern about Nocturnal GERD (mean 14.3 vs. 5.6, $p = 0.002$) were noted. No adverse events were reported.

[1290] The study indicated that in patients with nocturnal heartburn and regurgitation despite PPI use, the Medcline™ SPD significantly reduced nocturnal symptoms, morning impact of nocturnal GERD, and concern about nocturnal GERD after two weeks of use.

[1291] While various embodiments have been described above, it should be understood that they have been presented by way of example only, and not limitation. Where methods

described above indicate certain events occurring in certain order, the ordering of certain events may be modified. Additionally, certain of the events may be performed concurrently in a parallel process when possible, as well as performed sequentially as described above

[1292] Where schematics and/or embodiments described above indicate certain components arranged in certain orientations or positions, the arrangement of components may be modified. While the embodiments have been particularly shown and described, it will be understood that various changes in form and details may be made. Any portion of the apparatus and/or methods described herein may be combined in any combination, except mutually exclusive combinations. The embodiments described herein can include various combinations and/or sub-combinations of the functions, components and/or features of the different embodiments described.

[1293] For example, any of the embodiments of a cushion system can include a support element with a top surface that is angled at an angle between, for example, 6-30 degrees relative to a bottom surface of the support element. Any of the body elements described herein can include an arc portion and the arc portion can be curved, for example, between about 30 and about 180 degrees. In another example, any embodiment of cushion system can include one or more side bolsters and or one or more side support members. The body elements can include a first arm and a second arm having a variety of different lengths not necessarily shown. In addition, any of the body elements described herein can be used alone or with the support elements or base supports described herein.

EMBODIMENTS IN WHICH AN EXCLUSIVE PROPERTY OR PRIVILEGE IS CLAIMED ARE DEFINED AS FOLLOWS:

1. An apparatus comprising:

a base support including a support element portion and an encasement portion, the support element portion having a first end portion and a second end portion and a top surface disposed at an angle relative to a bottom surface, the second end portion of the support element portion having a height greater than a height of the first end portion of the support element portion, the second end portion of the support element portion and the encasement portion collectively defining an interior region bounded entirely about a perimeter of the interior region by a portion of the encasement portion and a portion of the second end portion of the support element portion; and

a support pillow member disposable within the interior region, the support pillow member, the second end portion of the support element portion and the encasement portion collectively defining a first receiving portion between the support pillow member and at least one of the second end portion of the support element portion or the encasement portion and a second receiving portion, opposite the first receiving portion, between the support pillow member and at least one of the second end portion of the support element portion or the encasement portion when the support pillow member is disposed within the interior region, the first receiving portion and the second receiving portion each configured to receive at least a portion of a user's arm therein.

2. The apparatus of claim 1, further comprising: a body element configured to be disposed on a top surface of at least one of the support element portion or the encasement portion, the body element having a first arm and a second arm connected by an arc portion.

3. The apparatus of claim 2, wherein the first arm and the second arm of the body element each extend away from the arc portion in substantially parallel directions.

4. The apparatus of claim 1, wherein the support pillow member includes a casing formed with a four-way stretch material and a polyester filler material disposed within the casing such that the combination of the four-way stretch material and the polyester filler material allows the support pillow member to be conformable.
5. The apparatus of claim 1, wherein the encasement portion has a substantially curved shape in a top view.
6. The apparatus of claim 1, wherein the base support defines a relief cavity in communication with the interior region.
7. The apparatus of claim 6, wherein the relief cavity includes an opening defined in a side edge of the base support.
8. The apparatus of claim 1, wherein the encasement portion extends from the second end portion of the support element portion.
9. The apparatus of claim 1, wherein the support pillow member includes a first side edge and an opposite second side edge, the receiving portion being disposed on at least one of the first side edge or the second side edge of the support pillow member.
10. The apparatus of claim 1, wherein the first receiving portion is bounded entirely about a perimeter of the first receiving portion by a portion of the support pillow member, a portion of the second end portion of the support element portion and a portion of the encasement portion when the support pillow member is disposed within the interior region and the second receiving portion is bounded entirely about a perimeter of the first receiving portion by a portion of the support pillow member, a portion of the second end portion of the support element portion and a portion of the encasement portion when the support pillow member is disposed within the interior region.

11. An apparatus comprising:

a base support including a support element portion and an encasement portion, the support element portion having a first end portion and a second end portion and a top surface disposed at an angle relative to a bottom surface, the second end portion of the support element portion having a height greater than a height of the first end portion of the support element portion, the support element portion having a centerline extending between the first end portion and the second end portion, the encasement portion extending from the second end portion of the support element portion, the support element portion and the encasement portion collectively defining an interior region bounded entirely about a perimeter of the interior region by a portion of the encasement portion and a portion of the second end portion of the support element portion; and

a support pillow member disposable within the interior region, the support pillow member, the support element portion and the encasement portion collectively defining a receiving portion configured to receive at least a portion of a user's arm therein when the support pillow member is disposed within the interior region, the receiving portion having a centerline laterally offset from the centerline of the support element portion.

12. The apparatus of claim 11, wherein the support pillow member includes a first side edge and an opposite second side edge, the receiving portion disposed on at least one of the first side edge or the second side edge of the support pillow member.

13. The apparatus of claim 11, further comprising: a body element configured to be disposed on a top surface of at least one of the support element portion or the encasement portion, the body element having a first arm and a second arm connected by an arc portion.

14. The apparatus of claim 11, wherein the support pillow member includes a casing formed with a four-way stretch material and a polyester filler material disposed within the casing such that the combination of the four-way stretch material and the polyester filler material allows the support pillow member to be conformable.

15. The apparatus of claim 11, wherein the encasement portion has a substantially curved shape in a top view.

16. The apparatus of claim 11, wherein the base support defines a relief cavity in communication with the interior region.

17. The apparatus of claim 16, wherein the relief cavity includes an opening defined in a side edge of the base support.

18. The apparatus of claim 11, wherein the receiving portion is bounded entirely about a perimeter of the receiving portion by a portion of the support pillow member, a portion of the second end portion of the support element portion and a portion of the encasement portion when the support pillow member is disposed within the interior region.

19. An apparatus comprising:

a base support including a support element portion and an encasement portion, the support element portion having a first end portion and a second end portion and a top surface disposed at an angle relative to a bottom surface, the second end portion having a height greater than a height of the first end portion, the support element portion and the encasement portion collectively defining an interior region between the support element portion and the encasement portion; and

a support pillow member disposable within the interior region, the support pillow member includes a first side wall and an opposite second side wall, the support pillow member, the support element portion and the encasement portion collectively defining a first receiving portion and a second receiving portion each configured to receive at least a portion of a user's arm therein when the support pillow member is disposed within the interior region, the first receiving portion being disposed between the encasement portion and one of the first side wall and the second side wall of the support pillow member, the second receiving portion being disposed between the other of the first side wall and the second side wall of the support pillow member.

20. The apparatus of claim 19, further comprising: a body element configured to be disposed on a top surface of at least one of the support element portion or the encasement portion, the body element having a first arm and a second arm connected by an arc portion.

21. The apparatus of claim 19, wherein the support pillow member includes a casing formed with a four-way stretch material and a polyester filler material disposed within the casing such that the combination of the four-way stretch material and the polyester filler material allows the support pillow member to be conformable.

22. The apparatus of claim 19, wherein the interior region is bounded entirely about a perimeter of the interior region by a portion of the encasement portion and a portion of the second end portion of the support element portion.

23. An apparatus, comprising:

a base support including a support element portion and an encasement portion, the support element portion having a first end portion and a second end portion and a top surface disposed at an angle relative to a bottom surface, the second end portion of the support element portion having a height greater than a height of the first end portion of the support element portion; and

a support pillow member fixedly coupled to the base support between at least a portion of the encasement portion and at least a portion the second end portion of the support element portion, the support pillow member having a first wall disposed at a first angle relative to a longitudinal centerline of the base support and a second wall on an opposite side of the support pillow member disposed at a second angle relative to the longitudinal centerline, the second wall angled in an opposite direction of the first wall,

the support pillow member, the support element portion and the encasement portion collectively defining an interior region, the interior region including a receiving portion configured to receive at least a portion of a user's arm therein.

24. The apparatus of claim 23, wherein the support pillow member is integrally formed with the encasement portion.

25. The apparatus of claim 23, wherein the support pillow member is formed with a first foam material and the encasement portion is formed with a second foam material different than the first foam material.

26. The apparatus of claim 23, wherein the base support defines a relief cavity in communication with the interior region, the relief cavity includes an opening defined in a side edge of the base support and extending at least partially to a front end portion of the base support.

27. The apparatus of claim 23, wherein the support pillow member and the encasement portion are integrally formed with a foam material.

28. The apparatus of claim 23, wherein the encasement portion extends from the second end portion of the support element portion.

29. The apparatus of claim 23, further comprising:
a body element configured to be disposed on a top surface of at least one of the support element portion or the encasement portion, the body element including a side support bolster.

30. An apparatus comprising:
a base support including a support element portion and an encasement portion, the support element portion having a first end portion and a second end portion and a top surface disposed at an angle relative to a bottom surface, the second end portion of the support element portion having a height greater than a height of the first end portion of the support element portion, the second end portion of the support element portion and the encasement portion collectively defining a bounded interior region; and

a support pillow member disposable within the interior region, the support pillow member, the second end portion of the support element portion and the encasement portion collectively defining a receiving portion between the support pillow member and at least one of the second end portion of the support element portion or the encasement portion when the support pillow member is disposed within the interior region, the receiving portion having a bounded perimeter having a smaller volume than the interior region and configured to receive at least a portion of a user's arm therein.

31. The apparatus of claim 30, further comprising: a body element configured to be disposed on a top surface of at least one of the support element portion or the encasement portion.

32. The apparatus of claim 31, wherein body element includes a first arm and a second arm connected by an arc portion, the first arm and the second arm of the body element each extend away from the arc portion in substantially parallel directions.

33. The apparatus of claim 30, wherein the support pillow member includes a casing formed with a four-way stretch material and a polyester filler material disposed within the casing such that the combination of the four-way stretch material and the polyester filler material allows the support pillow member to be conformable.

34. The apparatus of claim 30, wherein the encasement portion has a substantially curved shape in a top view.

35. The apparatus of claim 30, wherein the base support defines a relief cavity in communication with the interior region.

36. The apparatus of claim 35, wherein the relief cavity includes an opening defined in a side edge of the base support.

37. The apparatus of claim 30, wherein the encasement portion extends from the second end portion of the support element portion.

38. The apparatus of claim 30, wherein the support pillow member includes a first side edge and an opposite second side edge, the receiving portion being disposed on at least one of the first side edge or the second side edge of the support pillow member.

39. The apparatus of claim 30, wherein the receiving portion is bounded entirely about a perimeter of the receiving portion by a portion of the support pillow member, a portion of the second end portion of the support element portion and a portion of the encasement portion when the support pillow member is disposed within the interior region.

40. The apparatus of claim 39, wherein the receiving portion is a first receiving portion, the support pillow member, the second end portion of the support element portion and the encasement portion collectively defining a second receiving portion between the support pillow member and at least one of the second end portion of the support element portion or the encasement portion when the support pillow member is disposed within the interior region, the second receiving portion being disposed on an opposite side of the support pillow member than the first receiving portion.

41. The apparatus of claim 40, wherein the second receiving portion is bounded entirely about a perimeter of the second receiving portion by a portion of the support pillow member, a portion of the second end portion of the support element portion and a portion of the encasement portion when the support pillow member is disposed within the interior region.

42. An apparatus comprising:

a base support including a support element portion and an encasement portion, the support element portion having a first end portion and a second end portion and a top surface disposed at an angle relative to a bottom surface, the second end portion of the support element portion having a height greater than a height of the first end portion of the support element

portion, the support element portion having a centerline extending between the first end portion and the second end portion, the support element portion and the encasement portion collectively defining a bounded interior region; and

a support pillow member disposable within the interior region, the support pillow member, the support element portion and the encasement portion collectively defining a receiving portion configured to receive at least a portion of a user's arm therein when the support pillow member is disposed within the interior region, the receiving portion having a bounded perimeter and having a centerline laterally offset from the centerline of the support element portion.

43. The apparatus of claim 42, wherein the support pillow member includes a first side edge and an opposite second side edge, the receiving portion disposed on at least one of the first side edge or the second side edge of the support pillow member.

44. The apparatus of claim 42, further comprising: a body element configured to be disposed on a top surface of at least one of the support element portion or the encasement portion.

45. The apparatus of claim 42, wherein the support pillow member includes a casing formed with a four-way stretch material and a polyester filler material disposed within the casing such that the combination of the four-way stretch material and the polyester filler material allows the support pillow member to be conformable.

46. The apparatus of claim 42, wherein the encasement portion has a substantially curved shape in a top view.

47. The apparatus of claim 42, wherein the base support defines a relief cavity in communication with the interior region.

48. The apparatus of claim 47, wherein the relief cavity includes an opening defined in a side edge of the base support.

49. The apparatus of claim 42, wherein the receiving portion is bounded entirely about a perimeter of the receiving portion by a portion of the support pillow member, a portion of the second end portion of the support element portion and a portion of the encasement portion when the support pillow member is disposed within the interior region.

50. An apparatus comprising:

a base support including a support element portion and an encasement portion, the support element portion having a first end portion and a second end portion and a top surface disposed at an angle relative to a bottom surface, the second end portion having a height greater than a height of the first end portion, the support element portion and the encasement portion collectively defining an interior region between the support element portion and the encasement portion; and

a support pillow member disposable within the interior region, the support pillow member, the support element portion and the encasement portion collectively defining a first receiving portion and a second receiving portion each configured to receive at least a portion of a user's arm therein when the support pillow member is disposed within the interior region, the first receiving portion being disposed on an opposite side of the support pillow member than the second receiving portion.

51. The apparatus of claim 50, further comprising: a body element configured to be disposed on a top surface of at least one of the support element portion or the encasement portion.

52. The apparatus of claim 50, wherein the support pillow member includes a casing formed with a four-way stretch material and a polyester filler material disposed within the casing such that the combination of the four-way stretch material and the polyester filler material allows the support pillow member to be conformable.

53. The apparatus of claim 50, wherein the interior region is bounded entirely about a perimeter of the interior region by a portion of the encasement portion and a portion of the second end portion of the support element portion.

54. An apparatus for providing therapeutic treatment, comprising:

a support element portion having a first end portion and a second end portion and a top surface disposed at an angle relative to a bottom surface, the second end portion having a height greater than a height of the first end portion;

an encasement portion disposed proximate to the second end portion of the support element portion, the second end portion of the support element having an end surface facing the encasement portion, the end surface of the support element extending from a center portion of the support element toward a lateral side of the apparatus and being angled in a direction away from the encasement portion in a top view of the apparatus, the support element portion and the encasement portion collectively defining an interior region bounded entirely about a perimeter of the interior region by a portion of the encasement portion and a portion of the support element portion; and

a support pillow member disposable within the interior region, the support pillow member, the second end portion of the support element portion and the encasement portion collectively defining a receiving portion between the support pillow member and at least one of the second end portion of the support element portion or the encasement portion, the receiving portion configured to receive at least a portion of a user's arm therein.

55. The apparatus of claim 54, wherein the receiving portion is a first receiving portion, the support pillow member, the second end portion of the support element portion and the encasement portion collectively defining a second receiving portion between the support pillow member and at least one of the second end portion of the support element portion or the encasement portion when the support pillow member is disposed within the interior region, the second receiving portion configured to receive at least a portion of a user's arm therein.

56. The apparatus of claim 54, wherein the base support defines a relief cavity in communication with the interior region, the relief cavity defined at a bottom portion of the base support when the base support is placed on a support surface for use, the relief cavity configured to receive at least a portion of the user's arm or hand therethrough.

57. The apparatus of claim 54, wherein the receiving portion has a smaller volume than the interior region.

58. The apparatus of claim 54, further comprising:
a body element configured to be disposed on a top surface of at least one of the support element portion or the encasement portion,

59. The apparatus of claim 58, wherein the body element has a first arm and a second arm connected by an arc portion.

FIG. 1

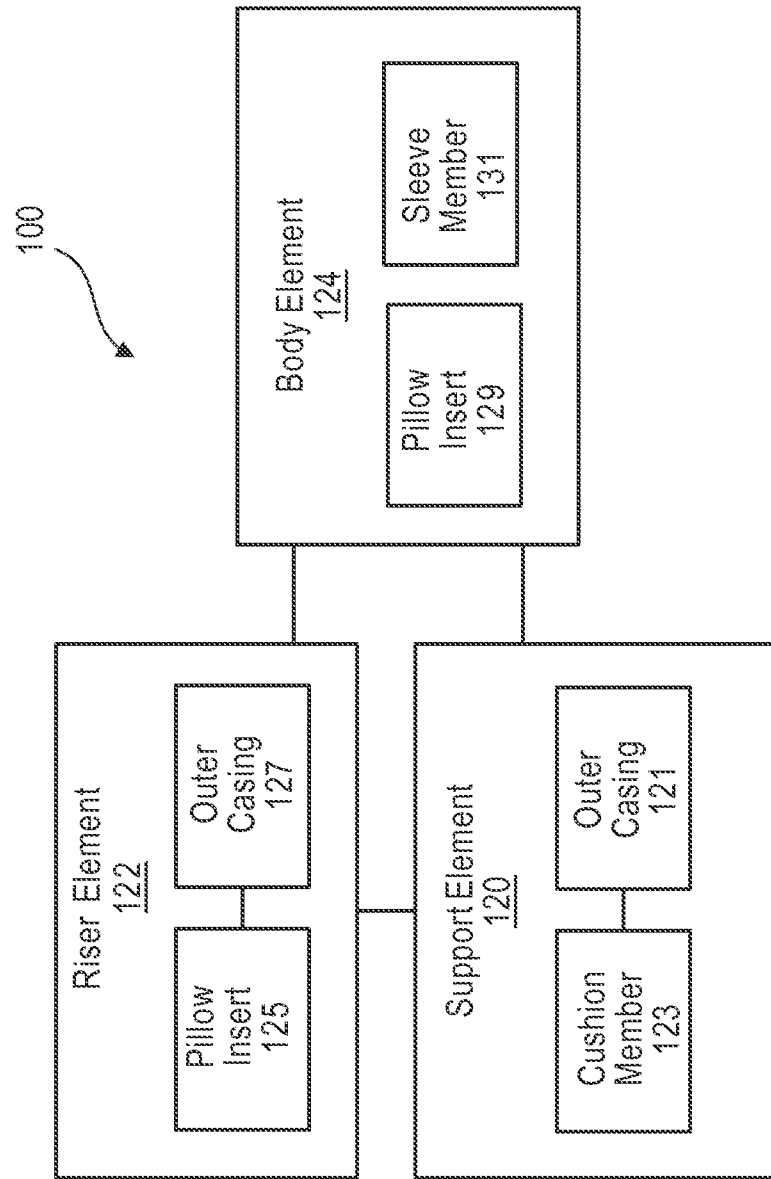

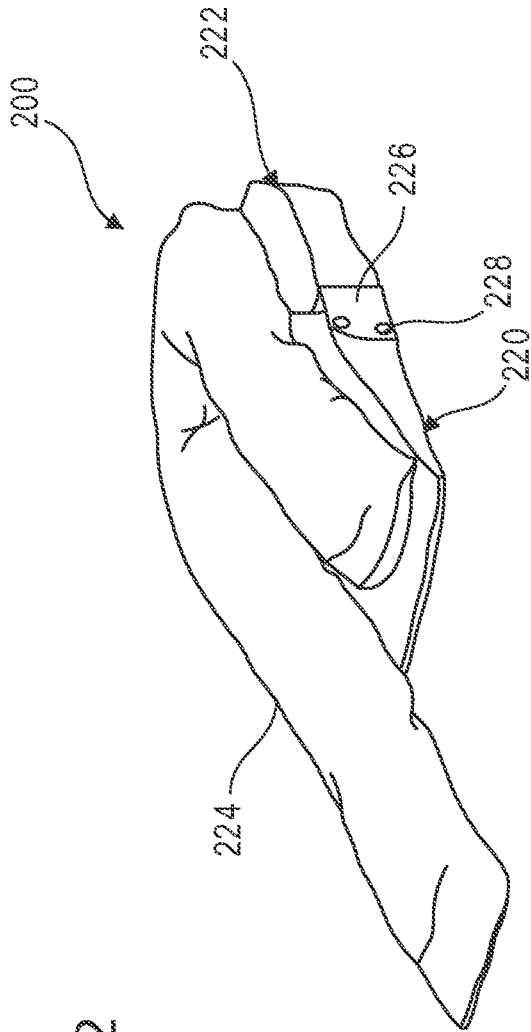

FIG. 2

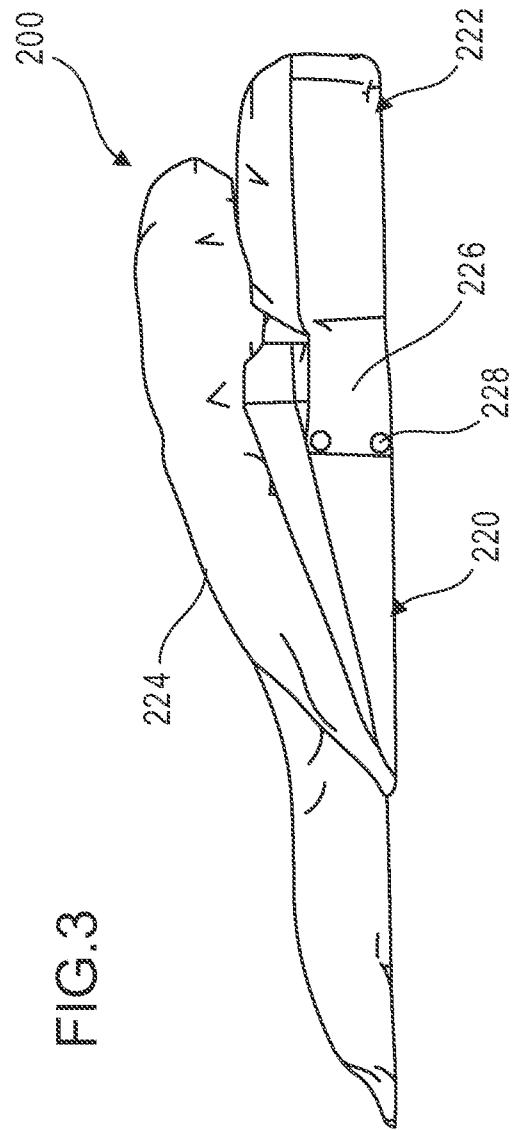

FIG. 3

FIG.4

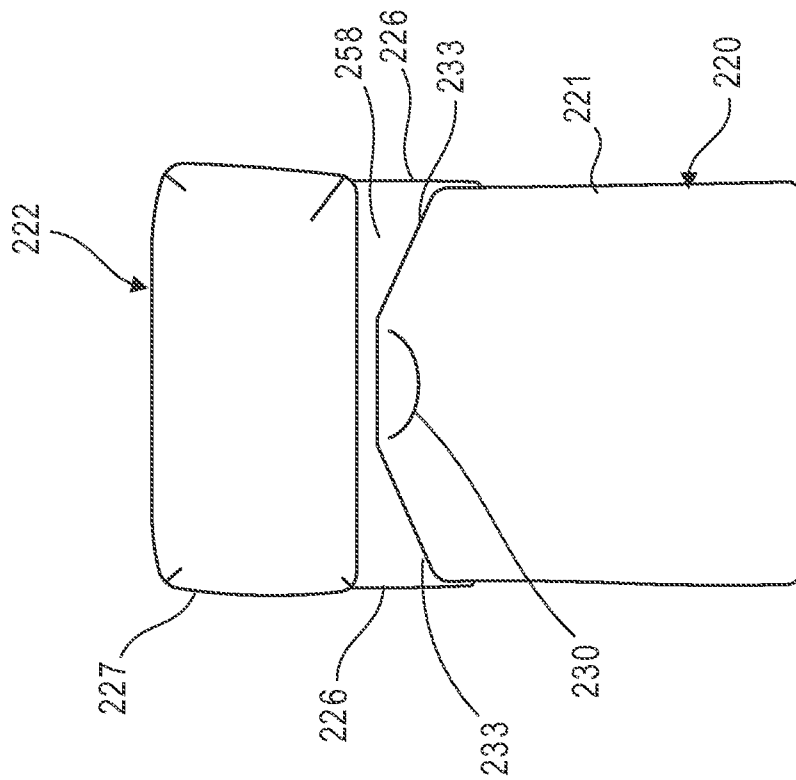

FIG.5

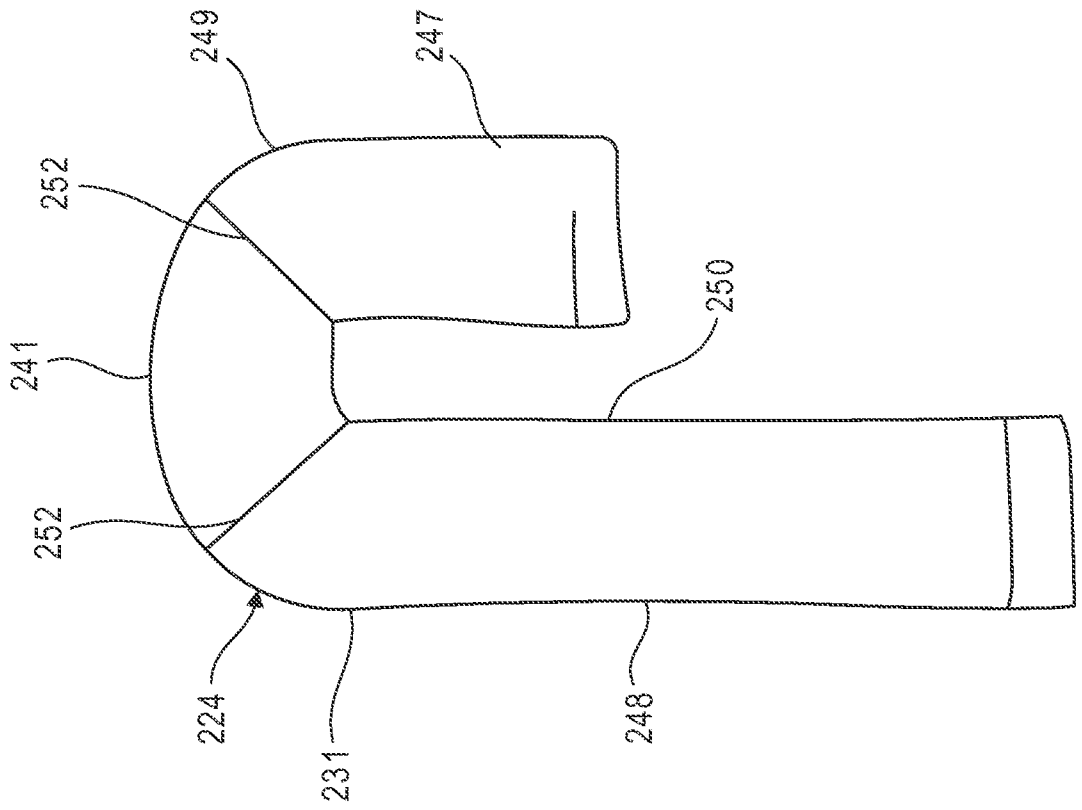

FIG.6

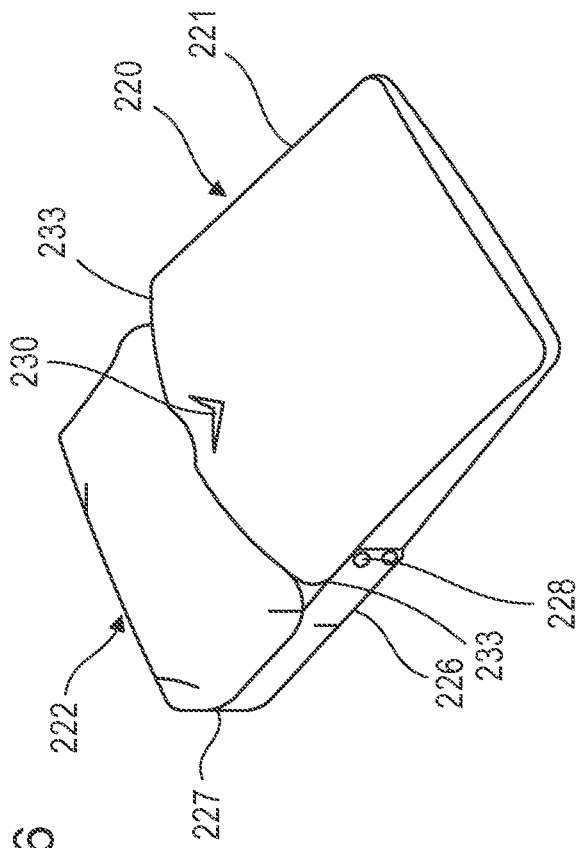

FIG.7

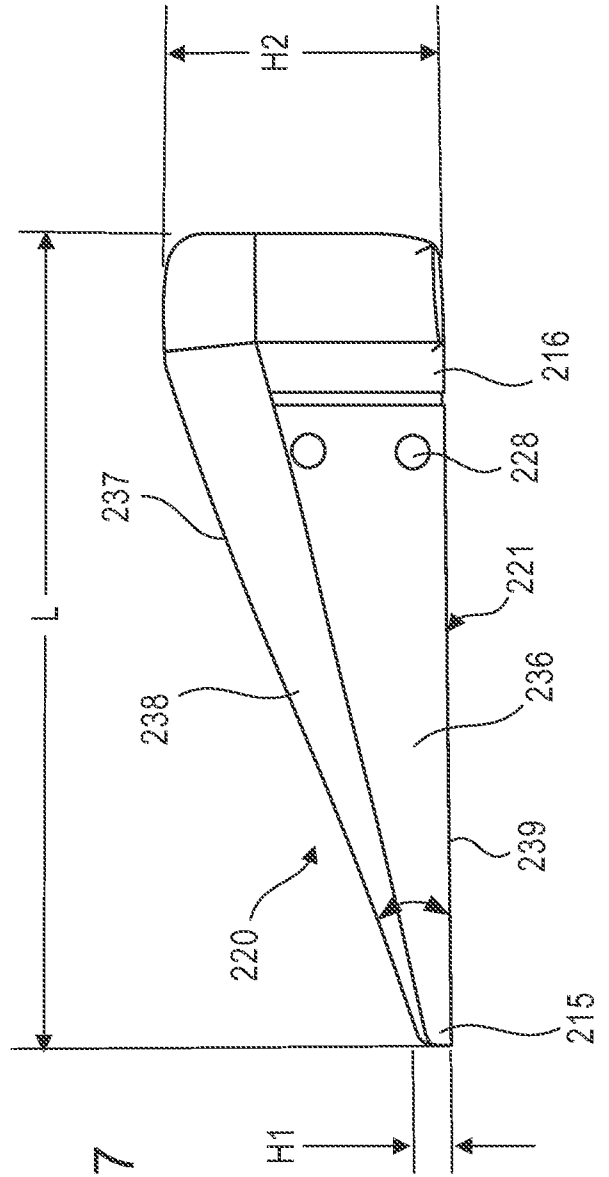

FIG.8

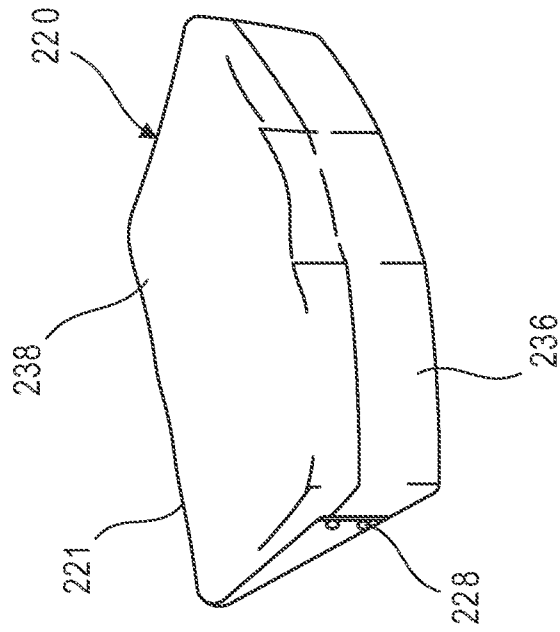
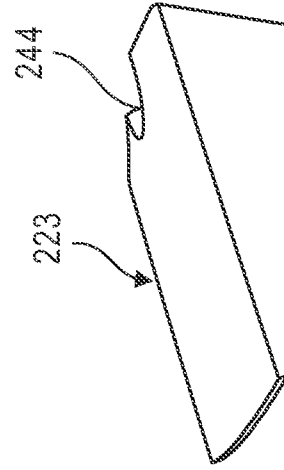

FIG.9



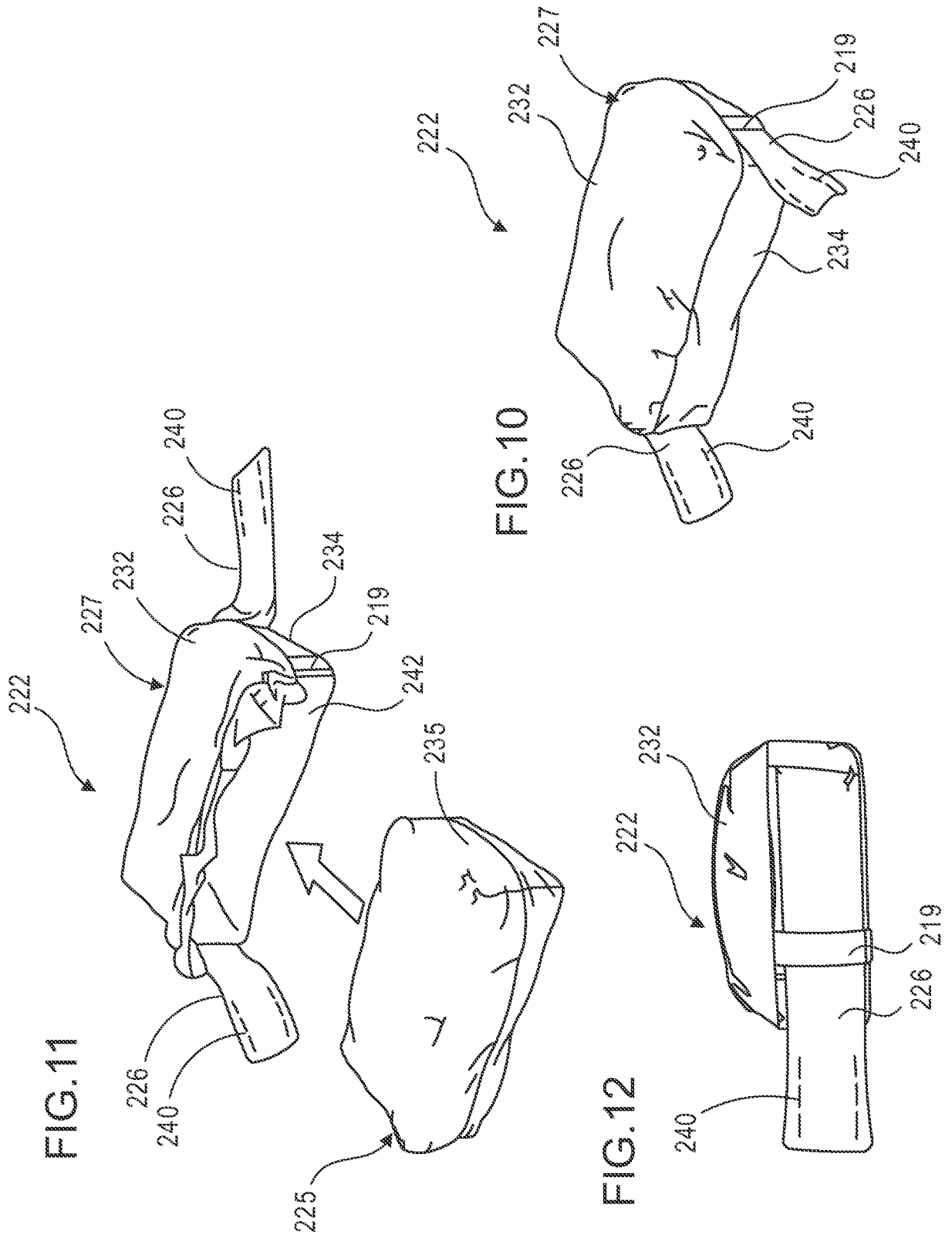

FIG.13

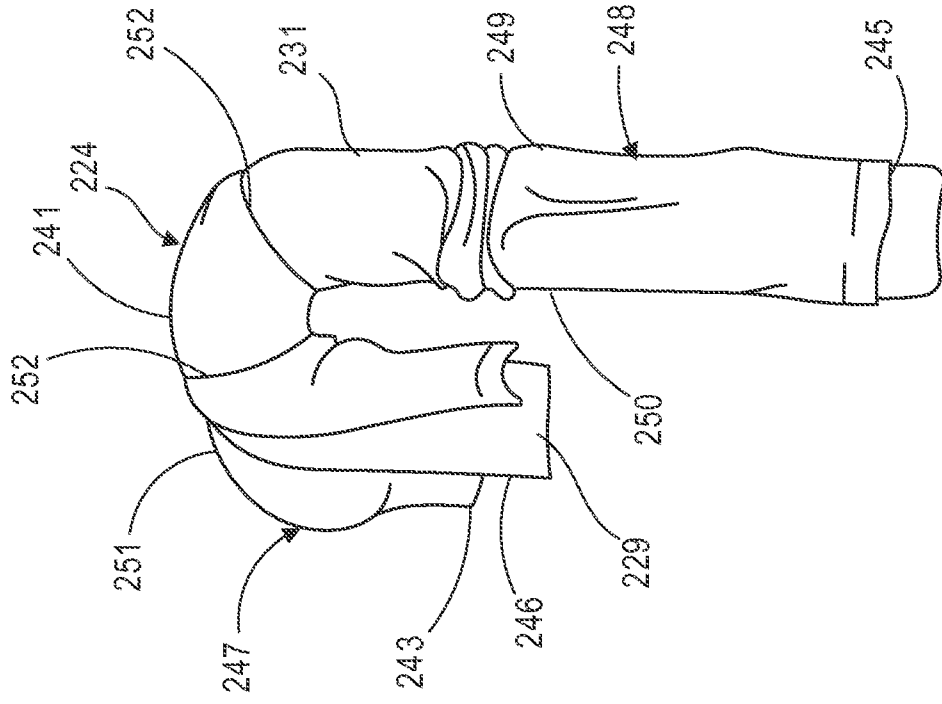

FIG. 14A

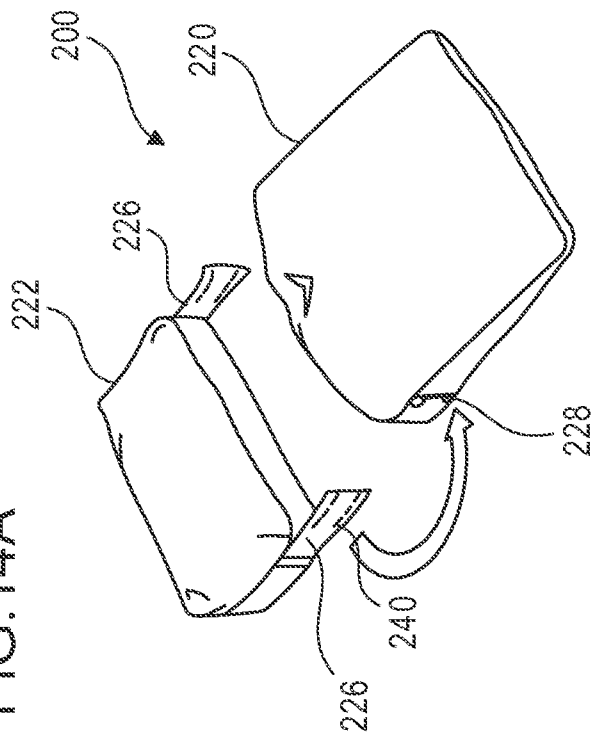

FIG. 14B

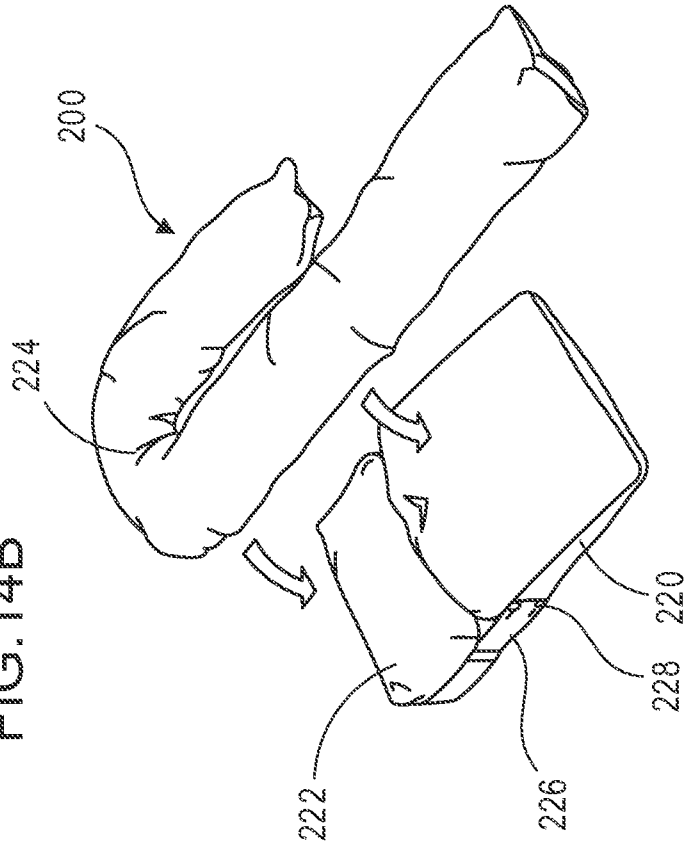

FIG.15A

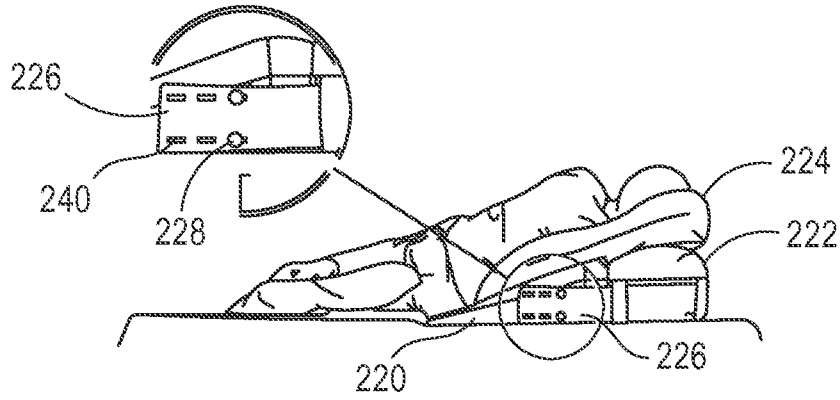

FIG.15B

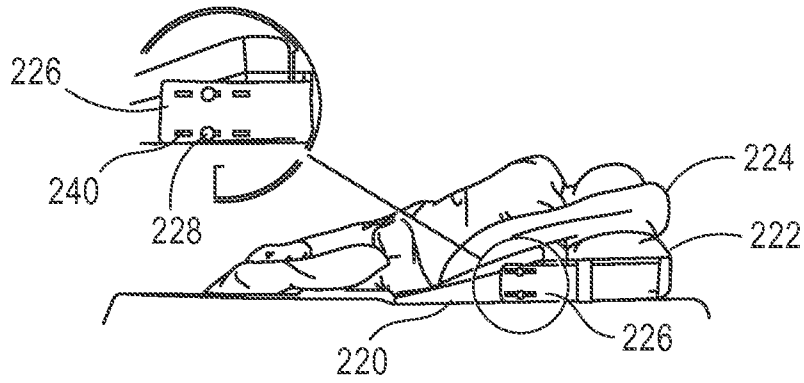

FIG.15C

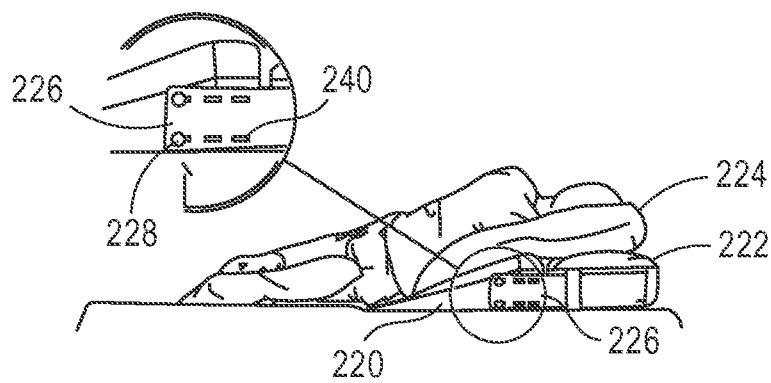

FIG.16

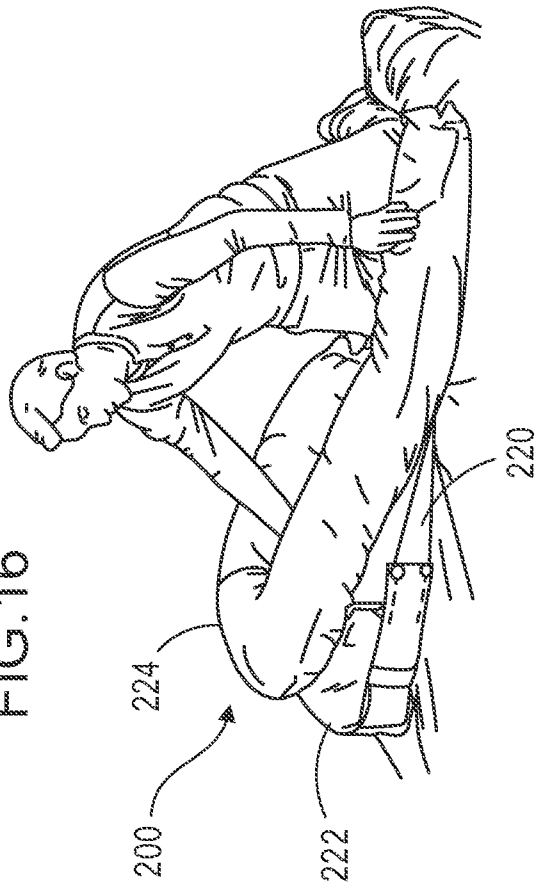

FIG.17

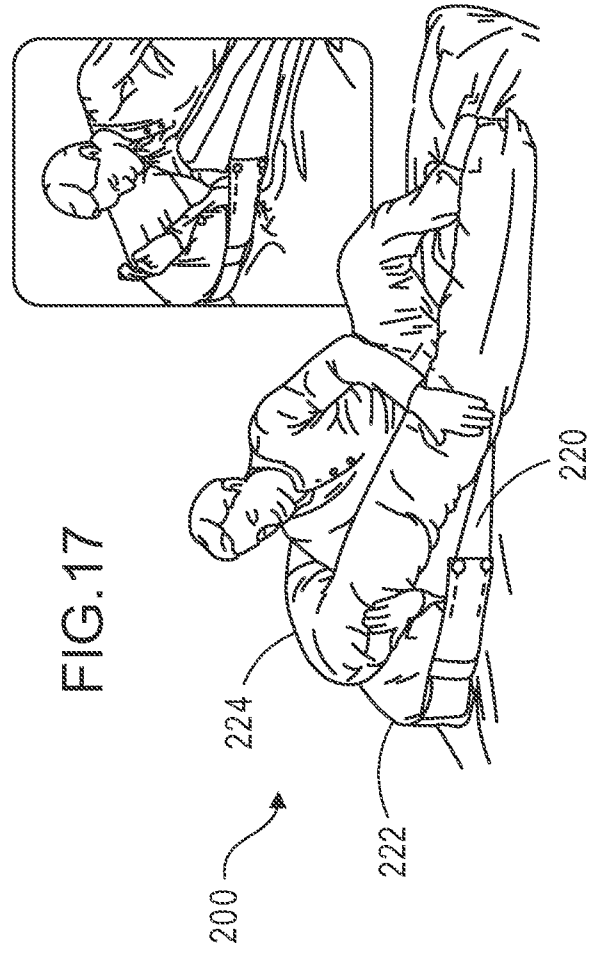

FIG.18

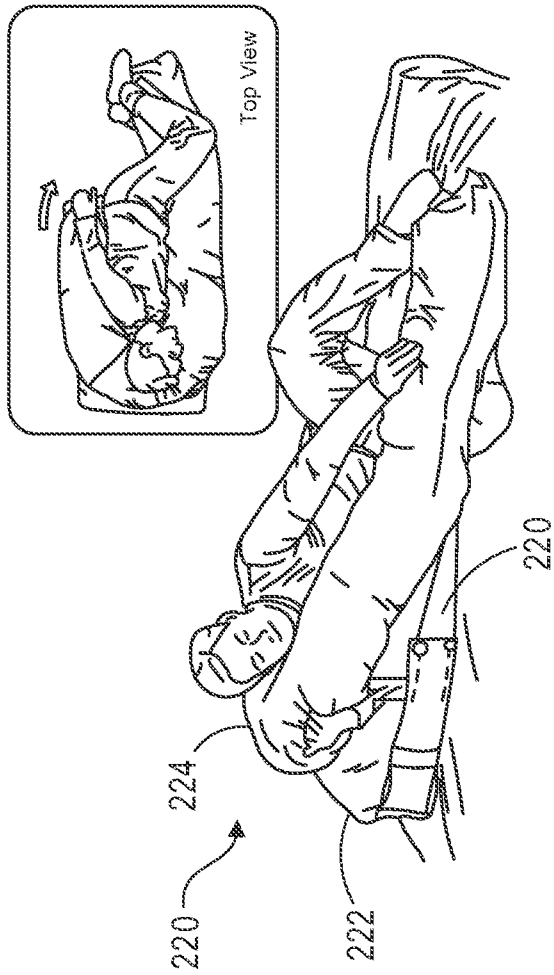

FIG.19

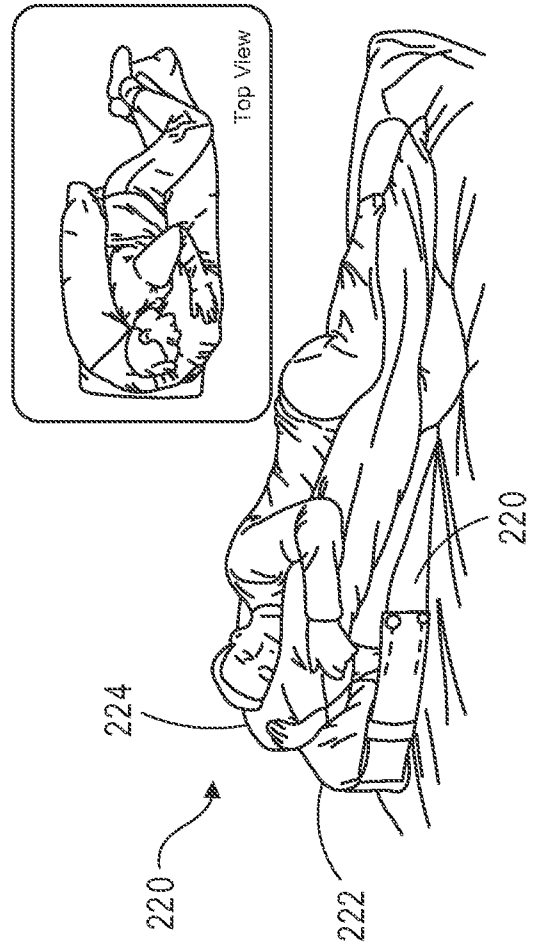

FIG.20

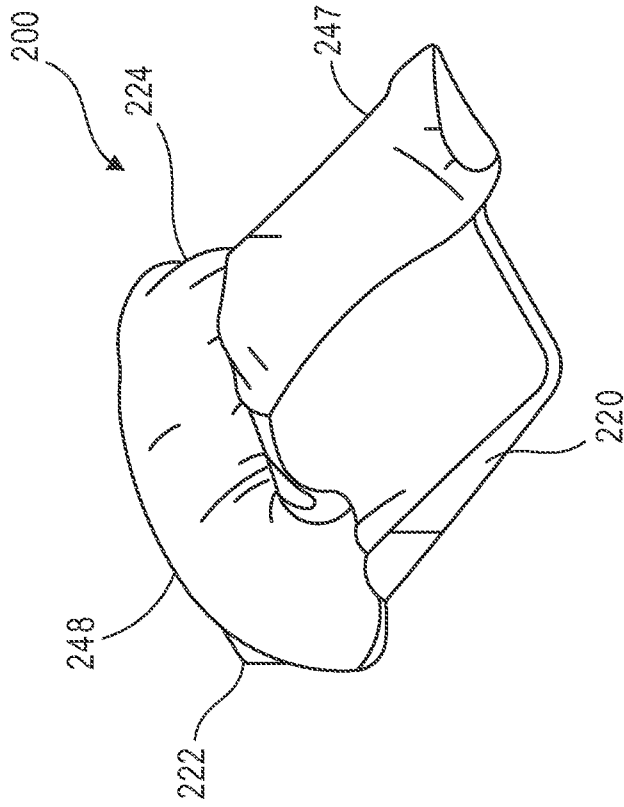

FIG.21

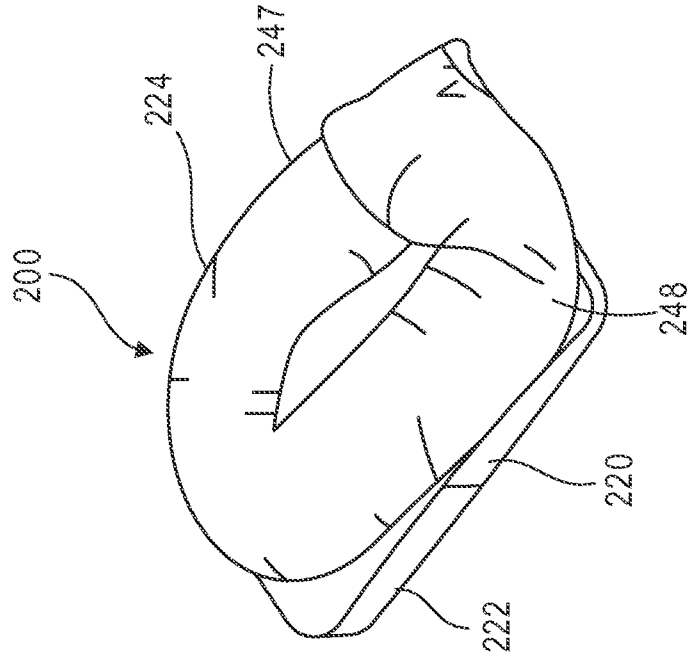

FIG.22

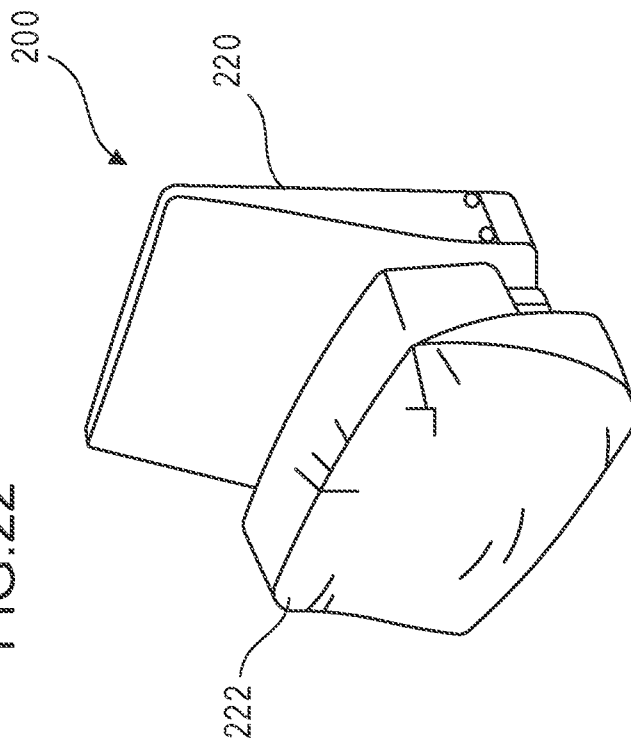

FIG.23

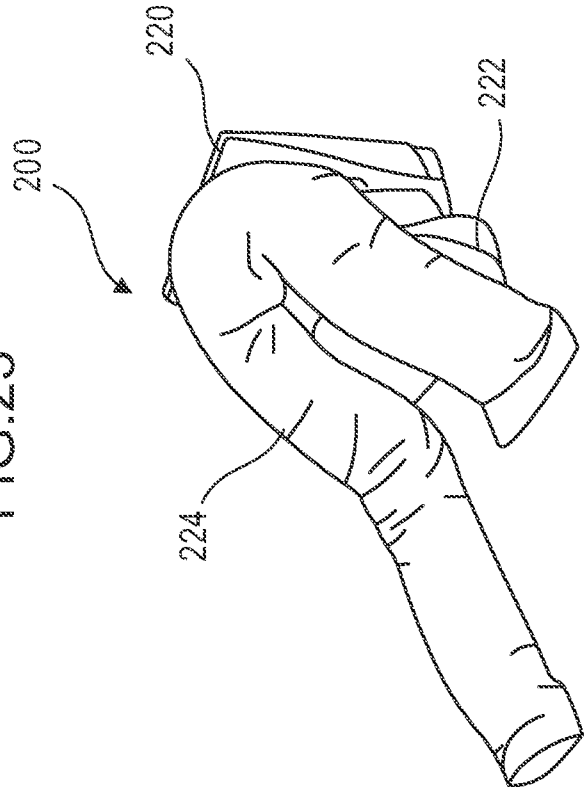

FIG.24

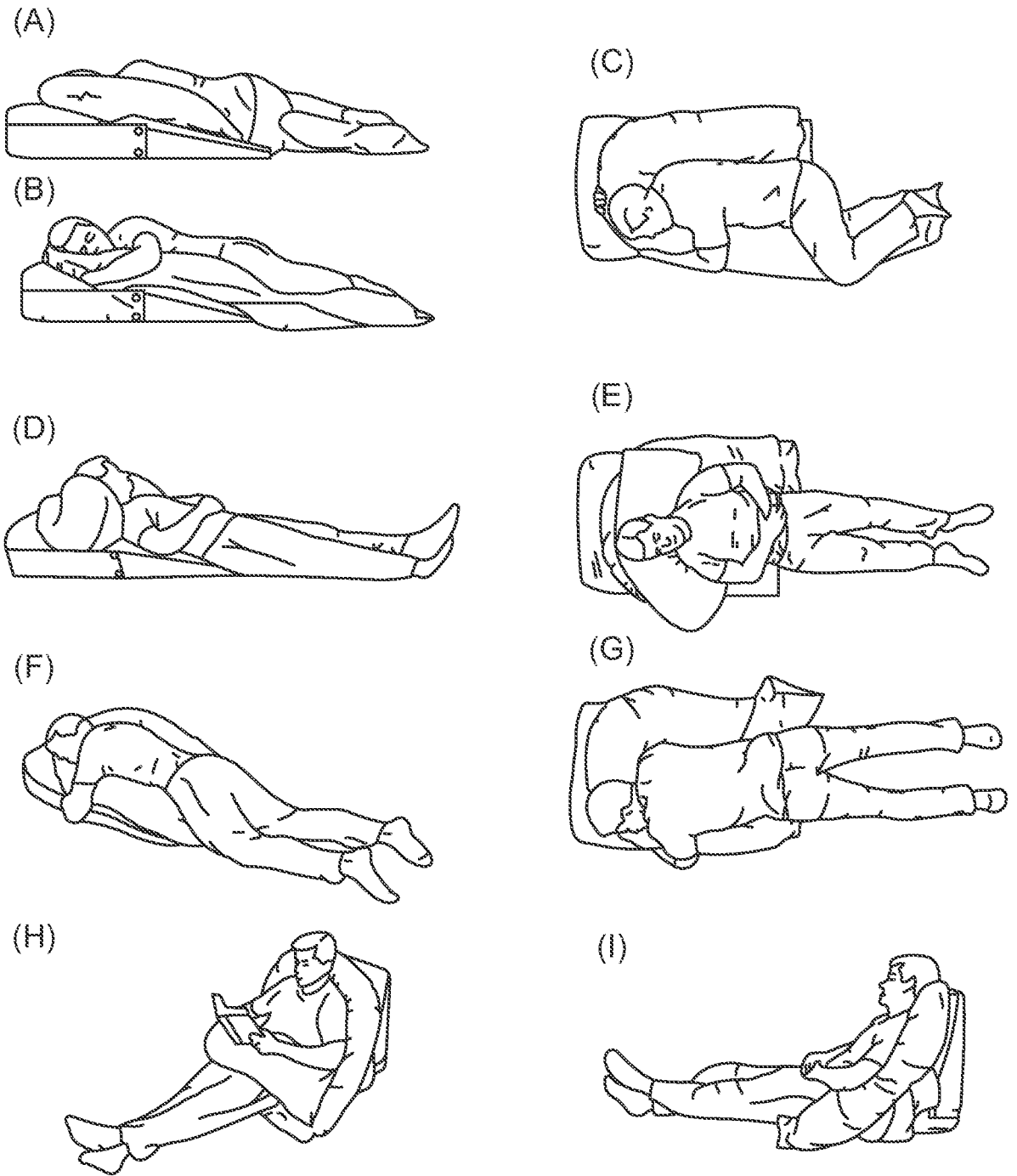

FIG.24(J)

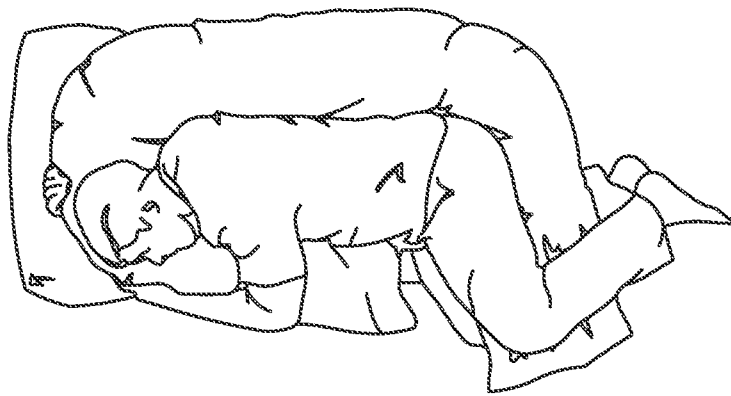

FIG.25

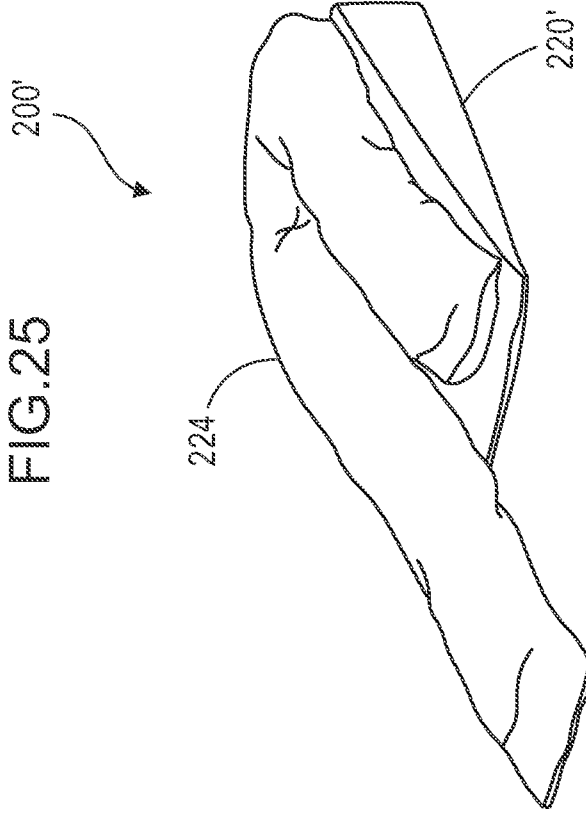

FIG.26

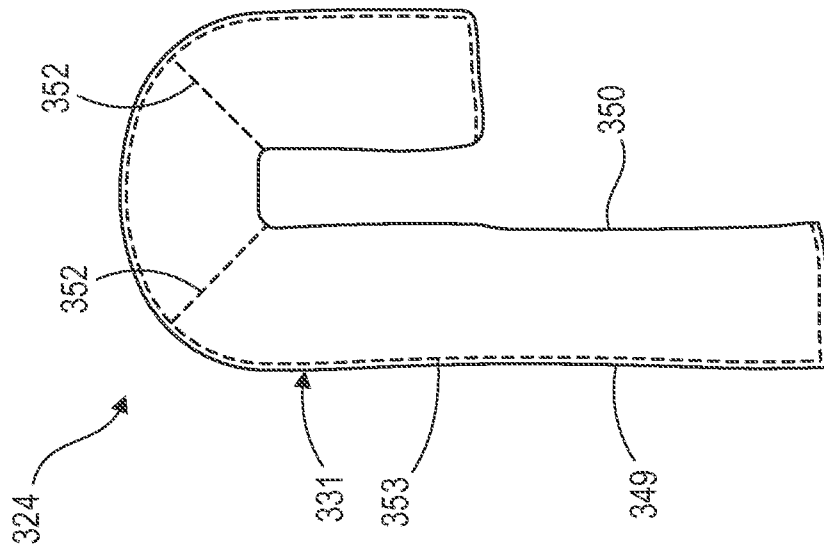

FIG.27

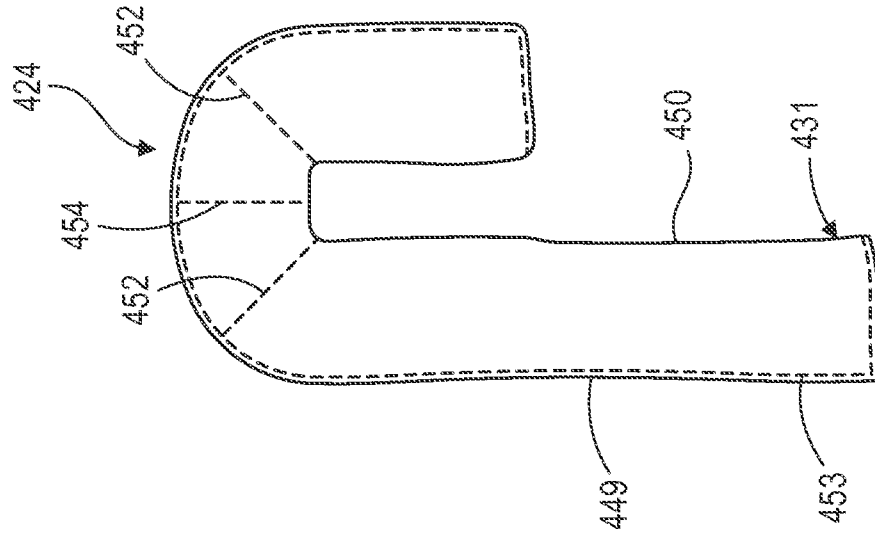

FIG.28

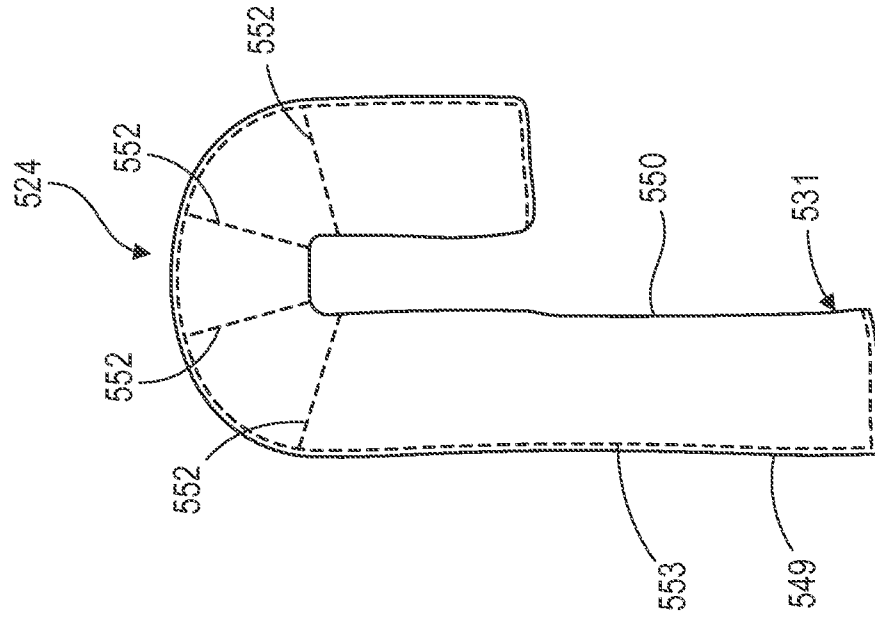
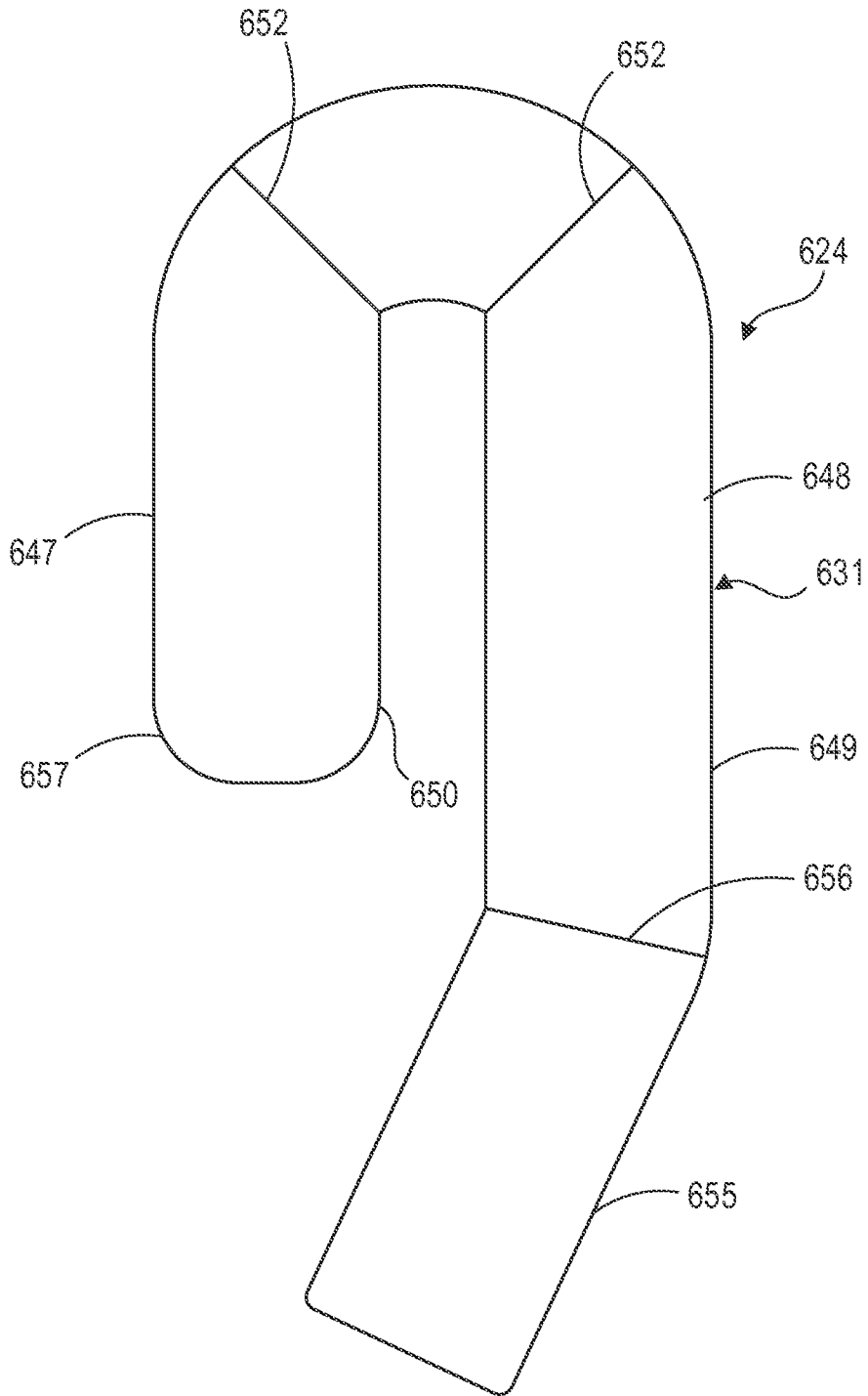

FIG.29



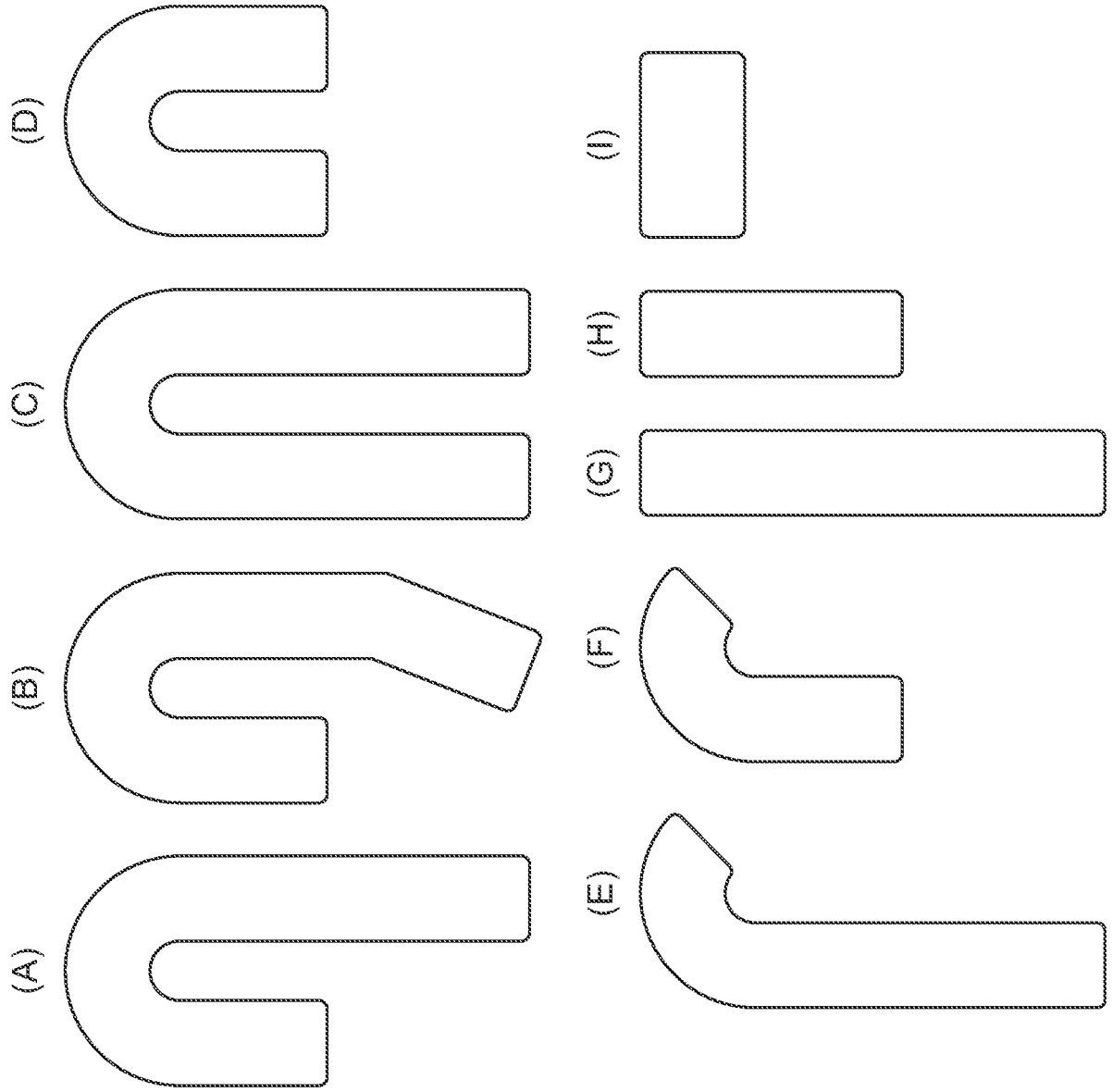

FIG.30

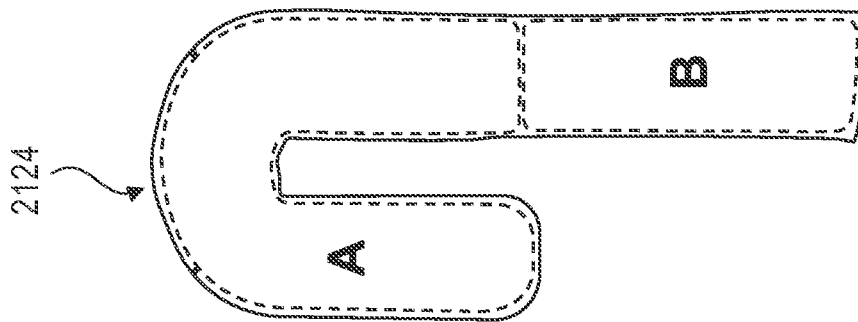

FIG. 31(A)

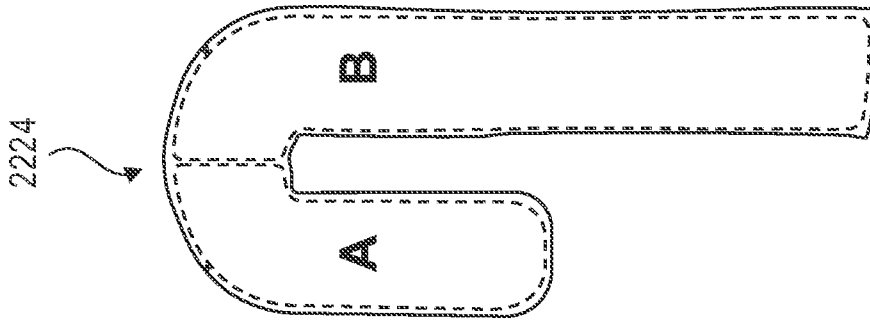

FIG. 31(B)

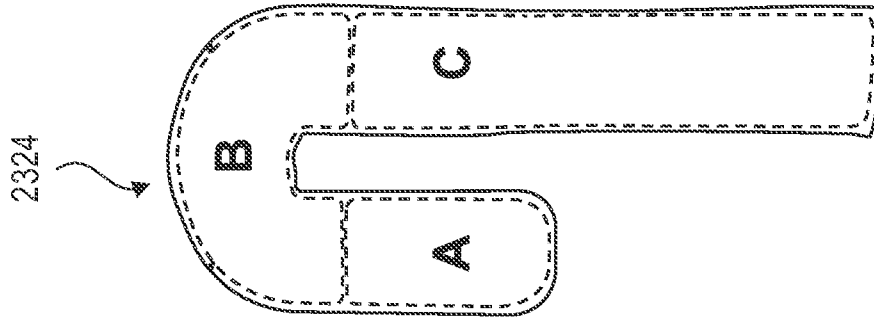

FIG. 31(C)

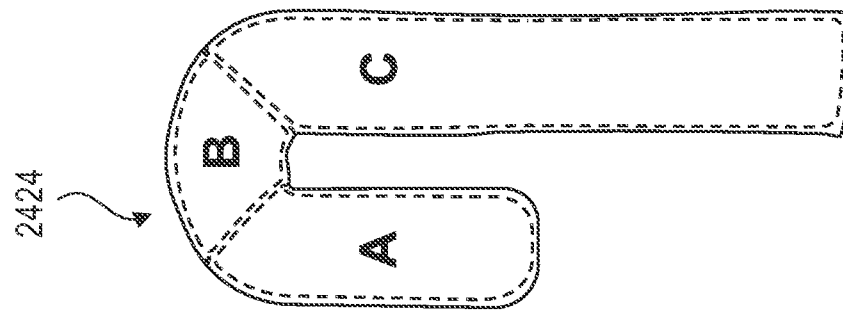
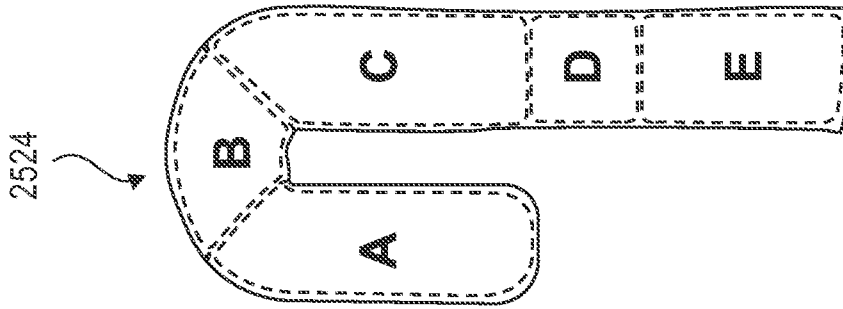

FIG.31(D)

FIG.31(E)

FIG.32(A)

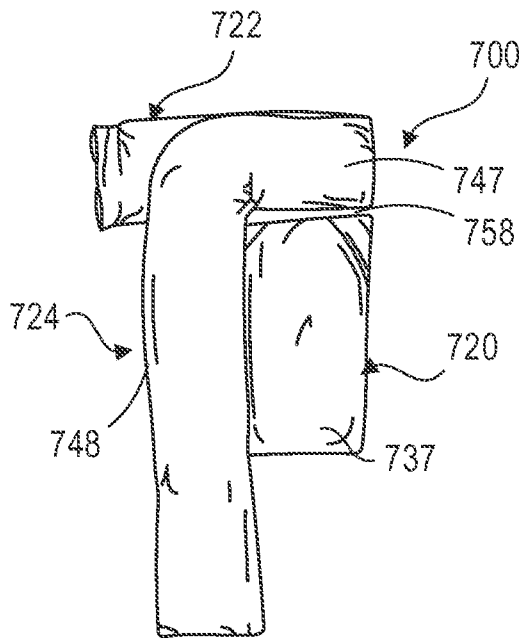

FIG.32(B)

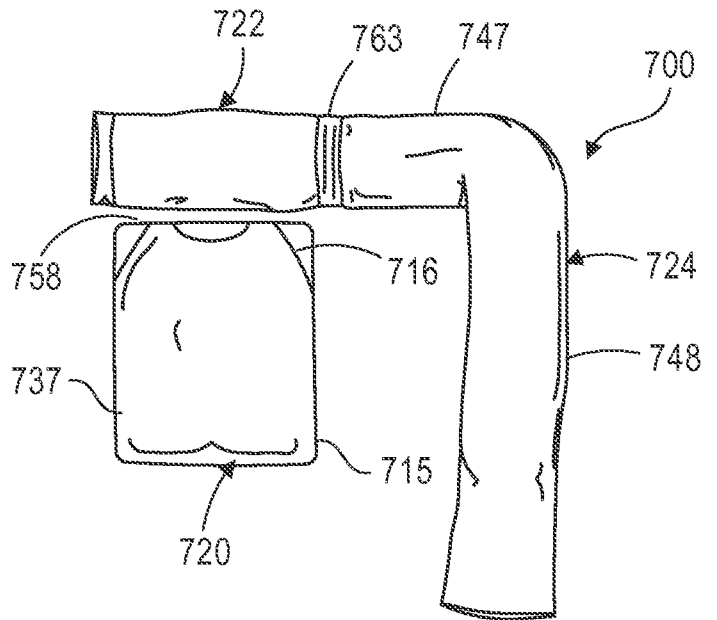

FIG.33

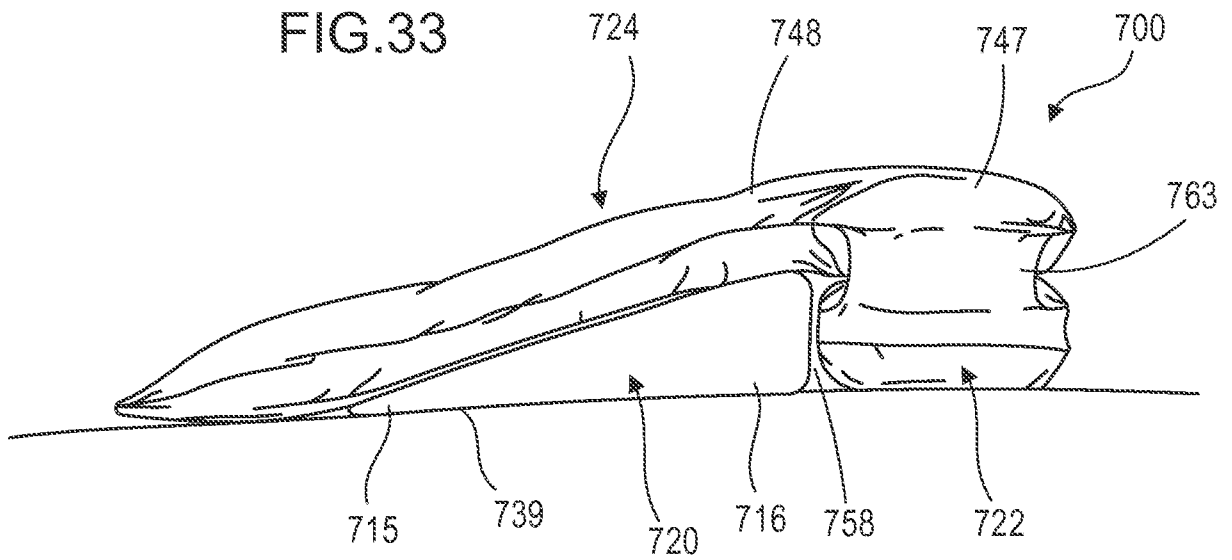

FIG.34

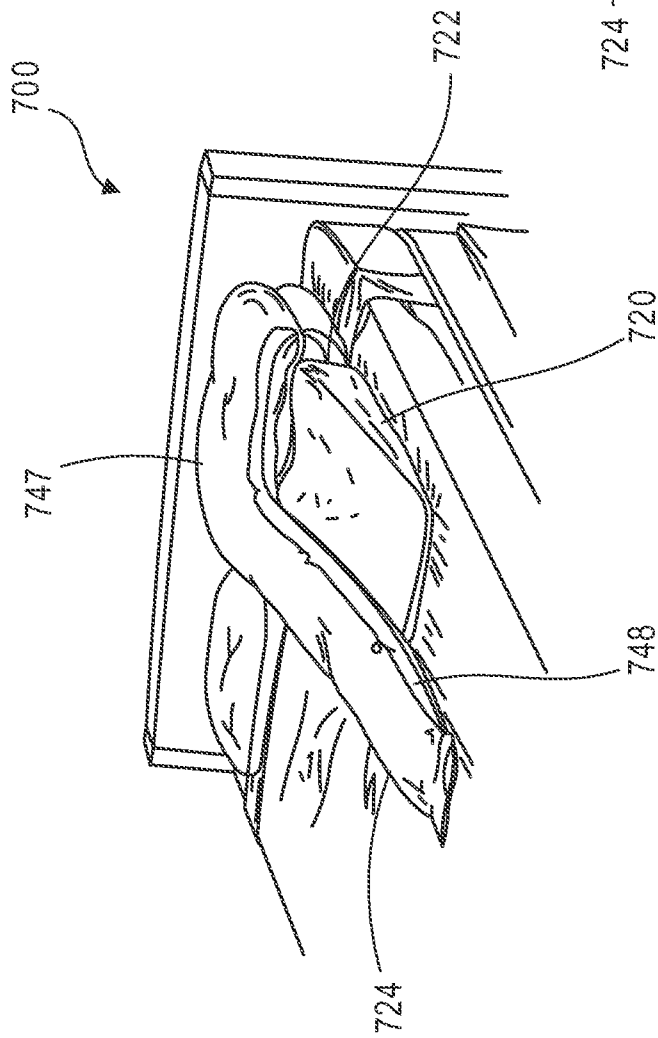
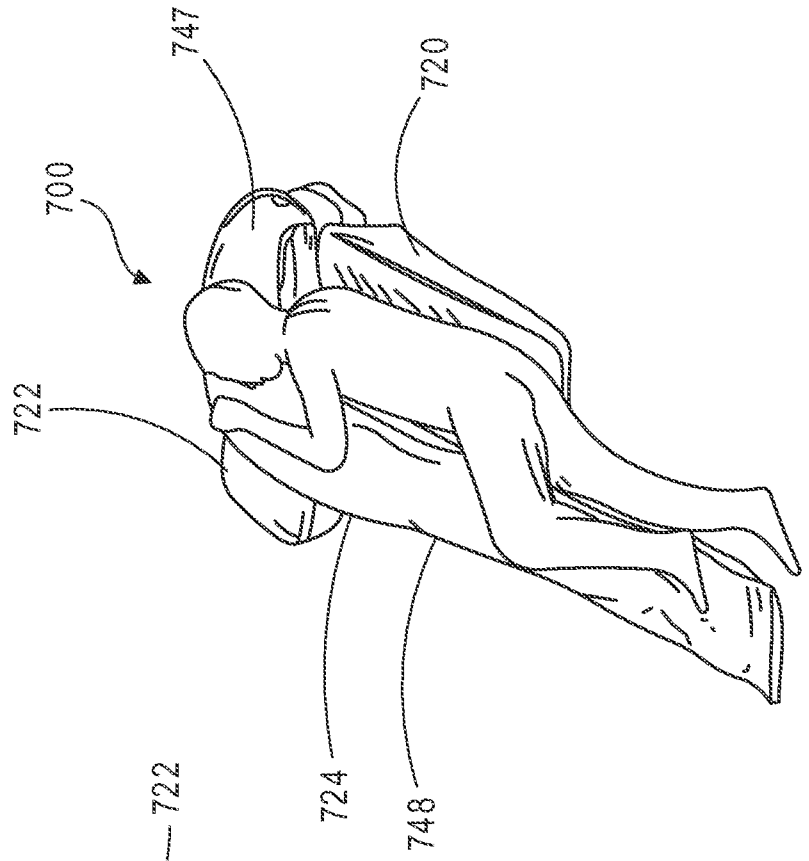

FIG.35



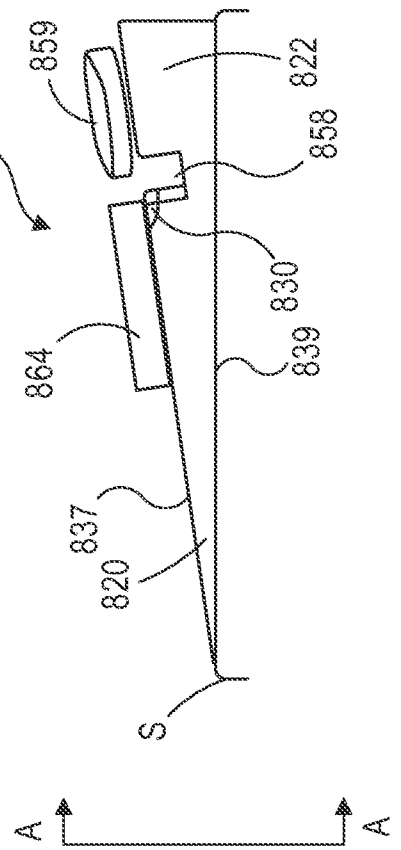
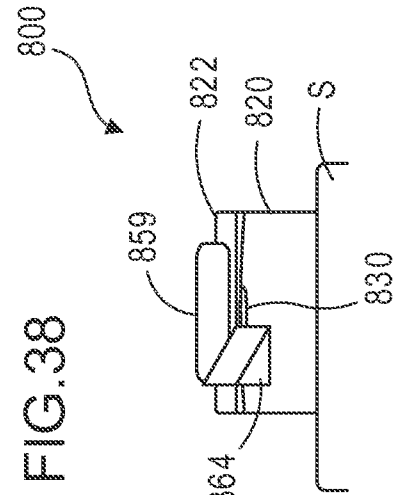
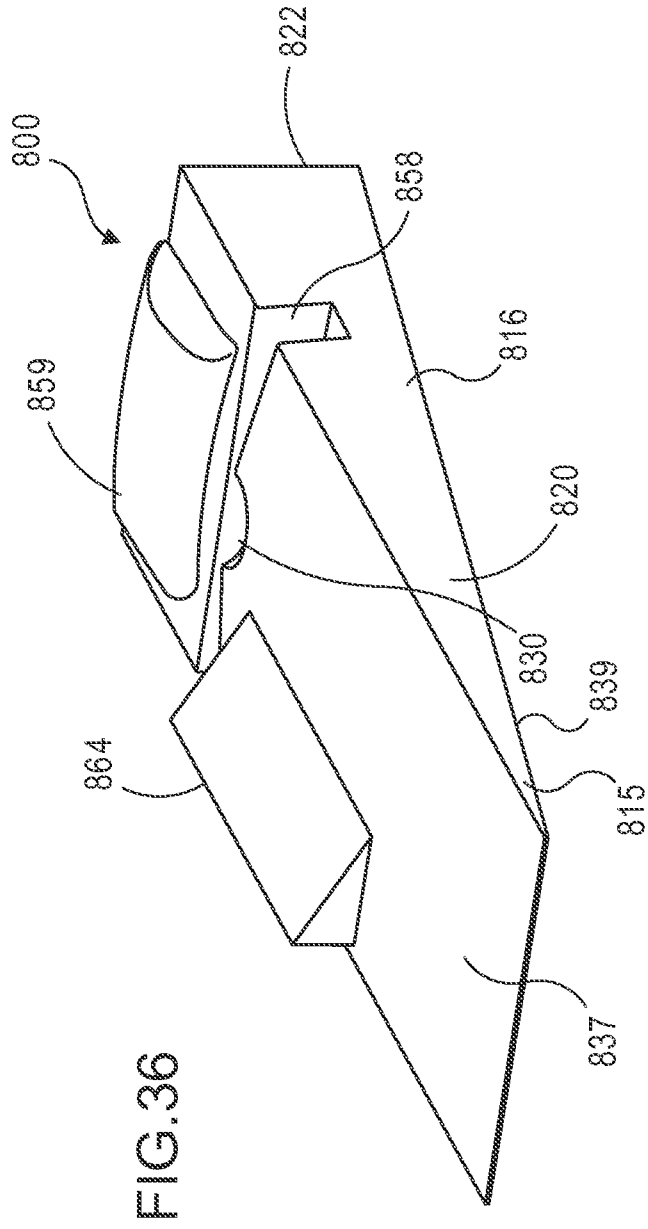

FIG.39

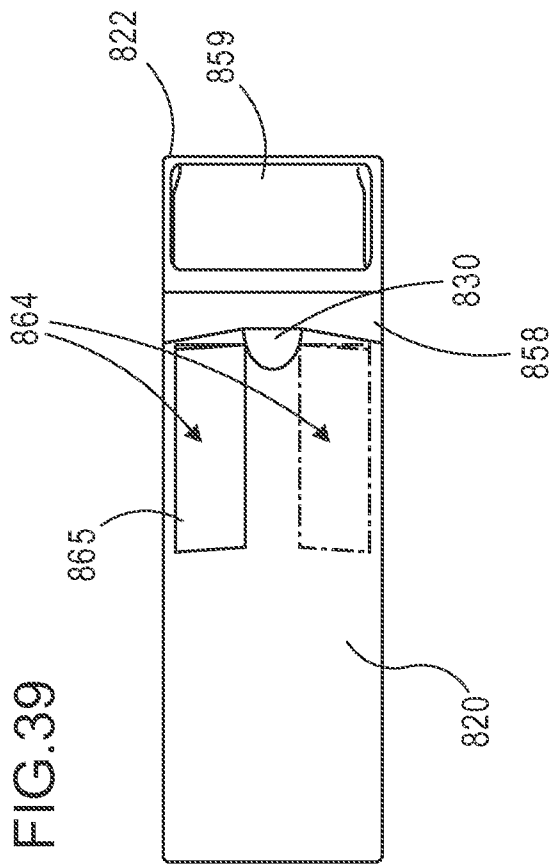

FIG.40

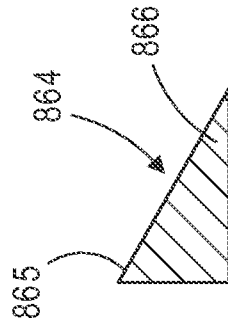

FIG.41

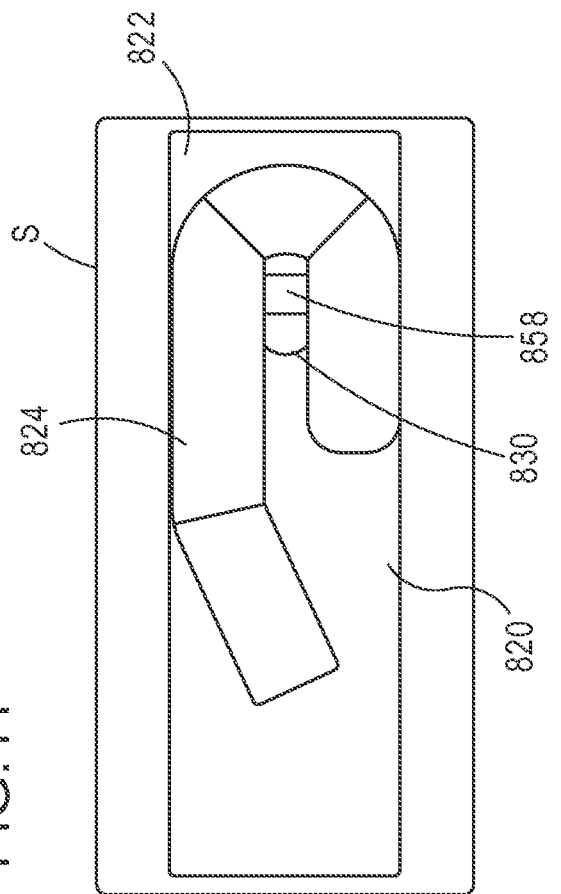

FIG.42

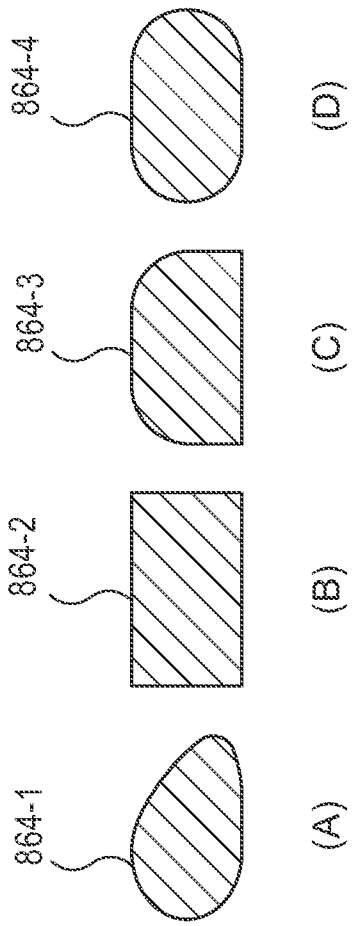

FIG.43

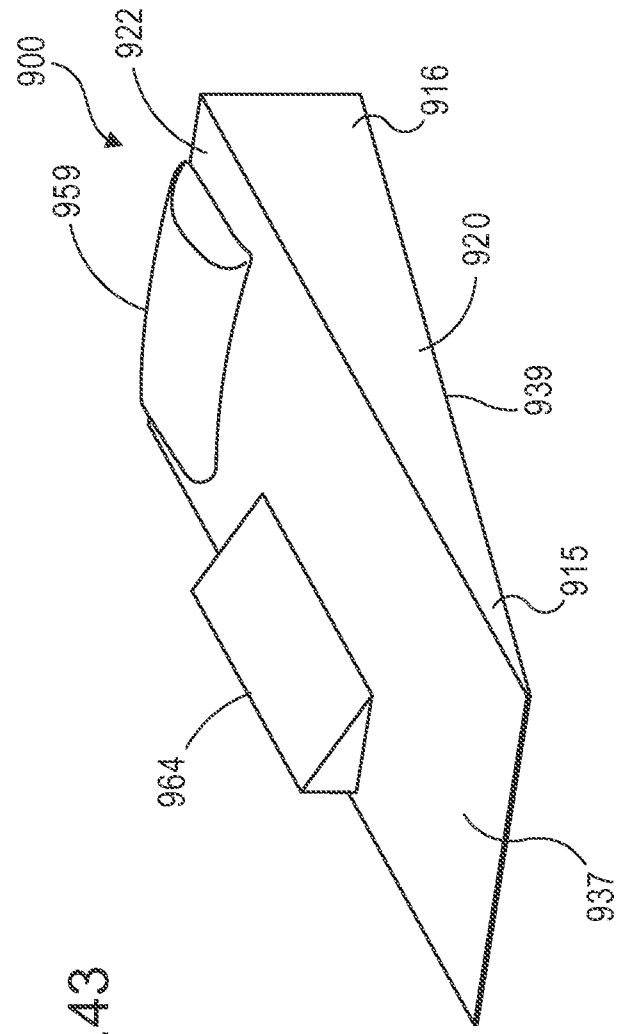

FIG.44

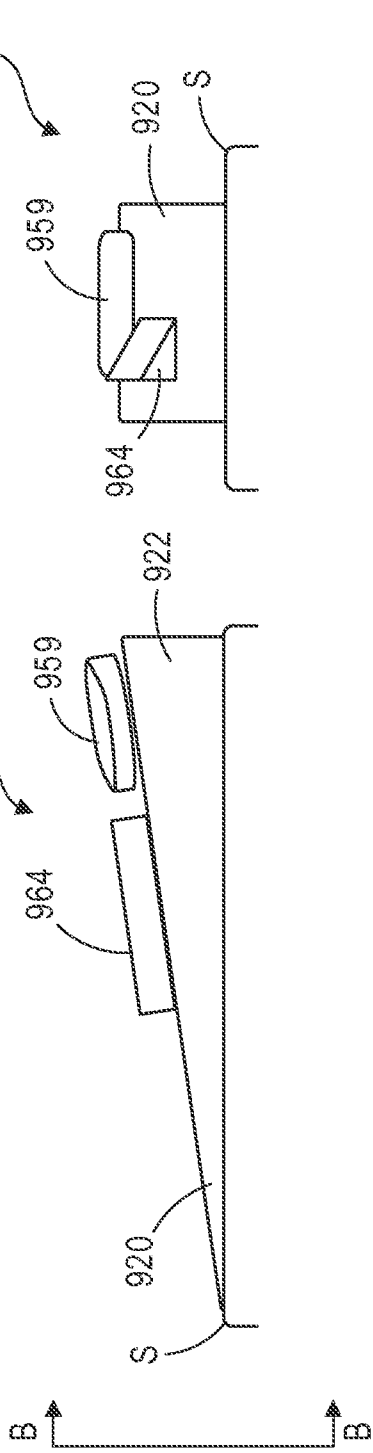

FIG.45

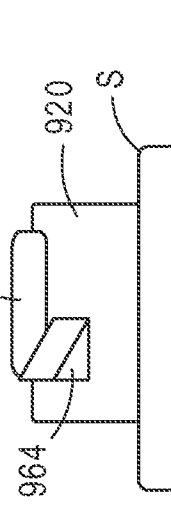

FIG.47

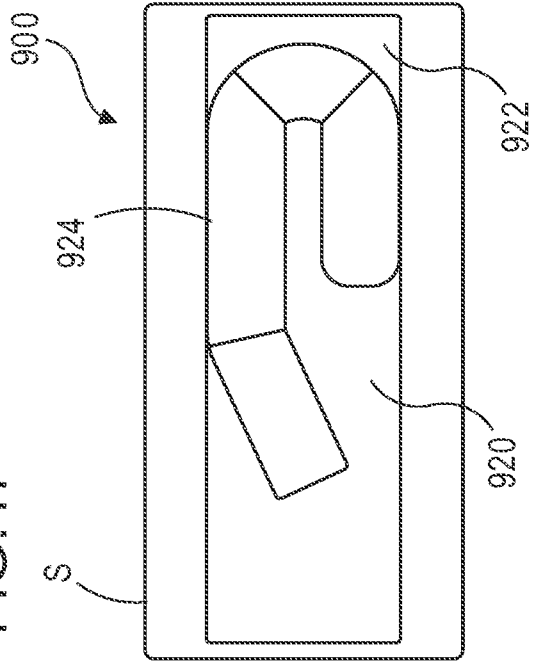

FIG.46

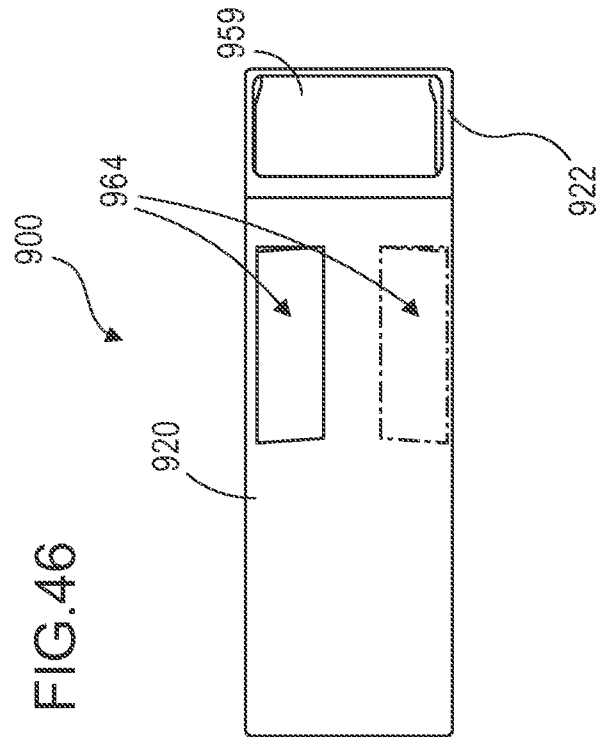

FIG.49

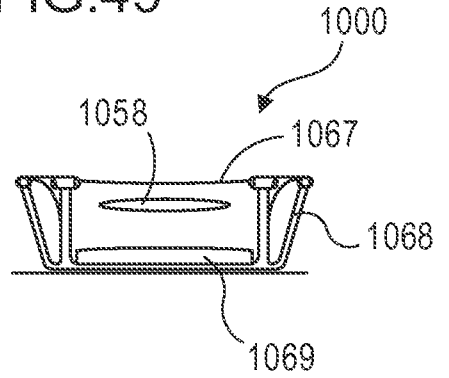

FIG.48

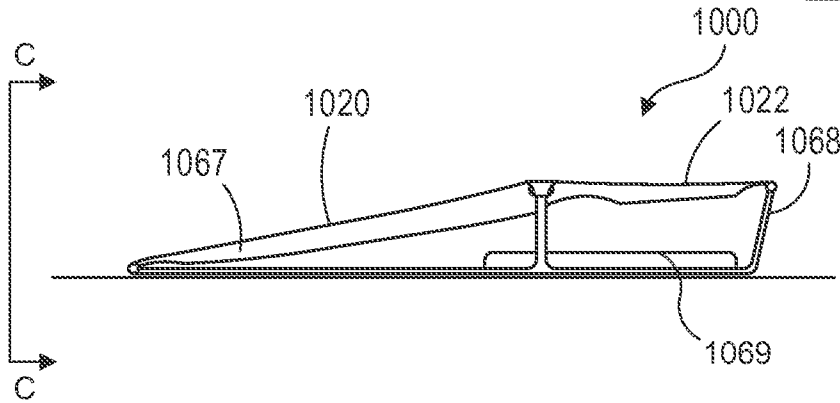

FIG.50

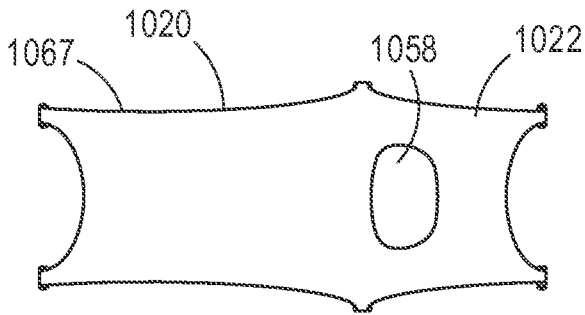

FIG.51

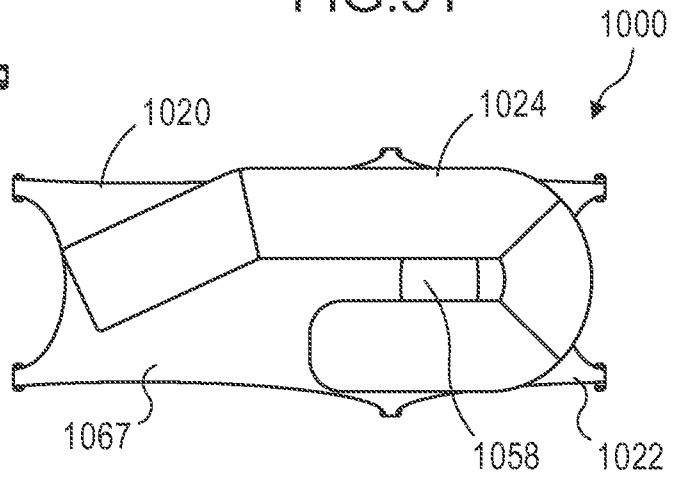

FIG.52

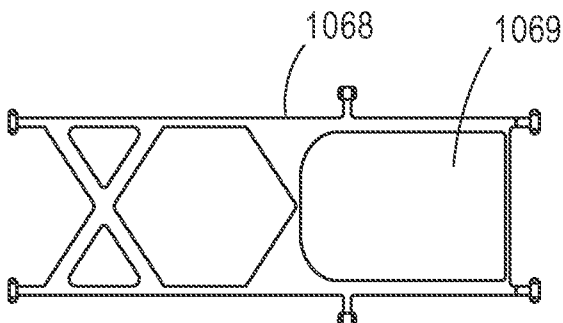

FIG.53

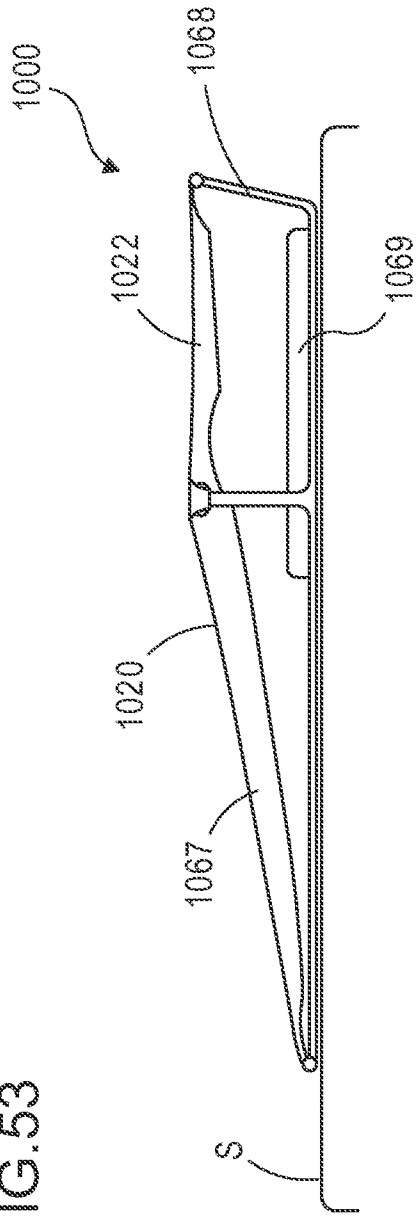

FIG.54

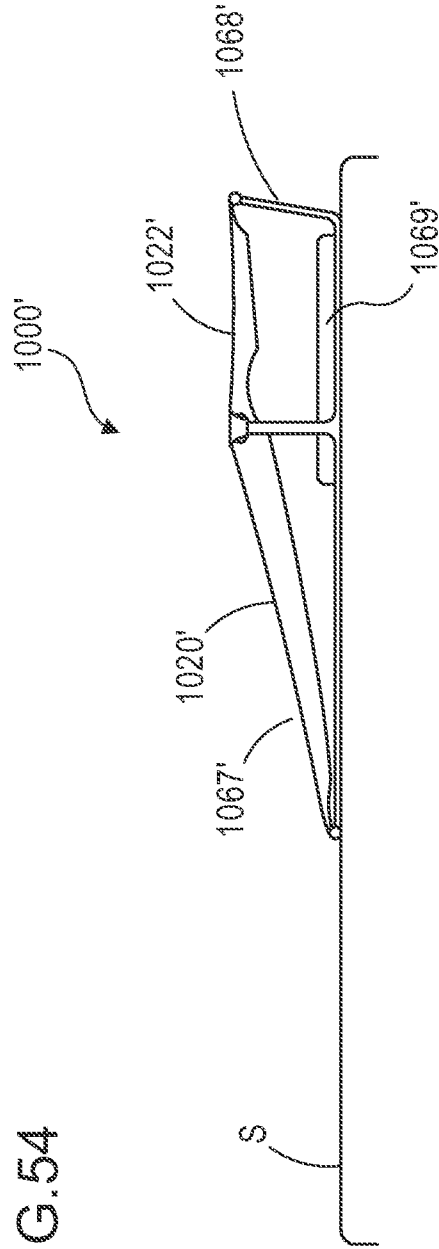

FIG.55

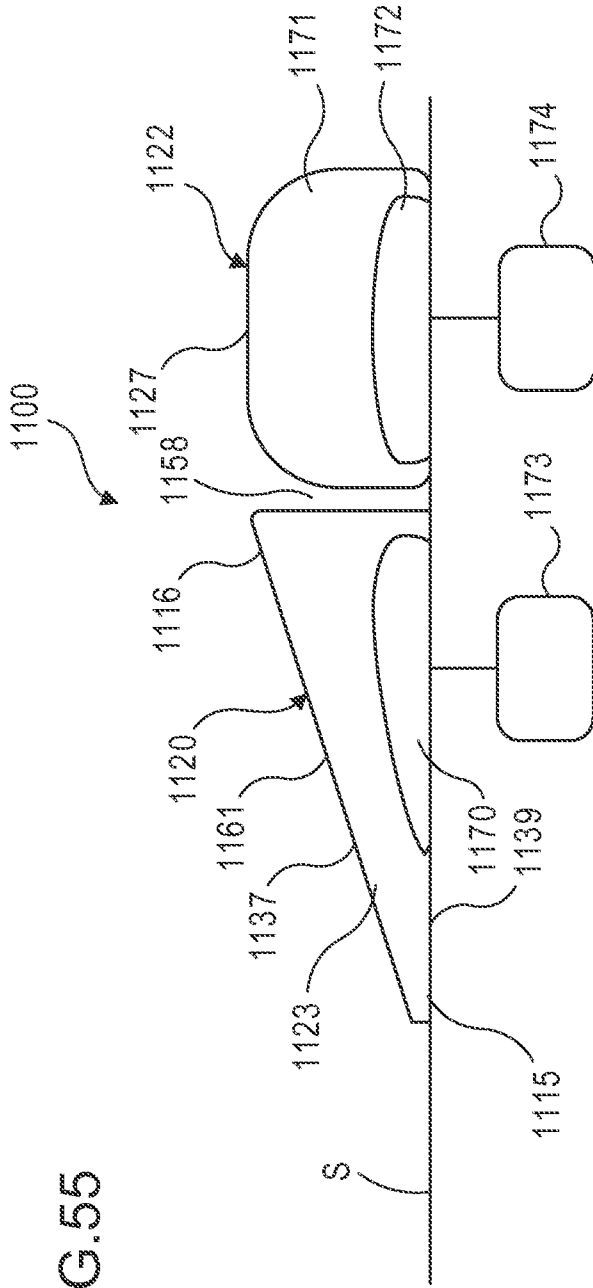

FIG.56

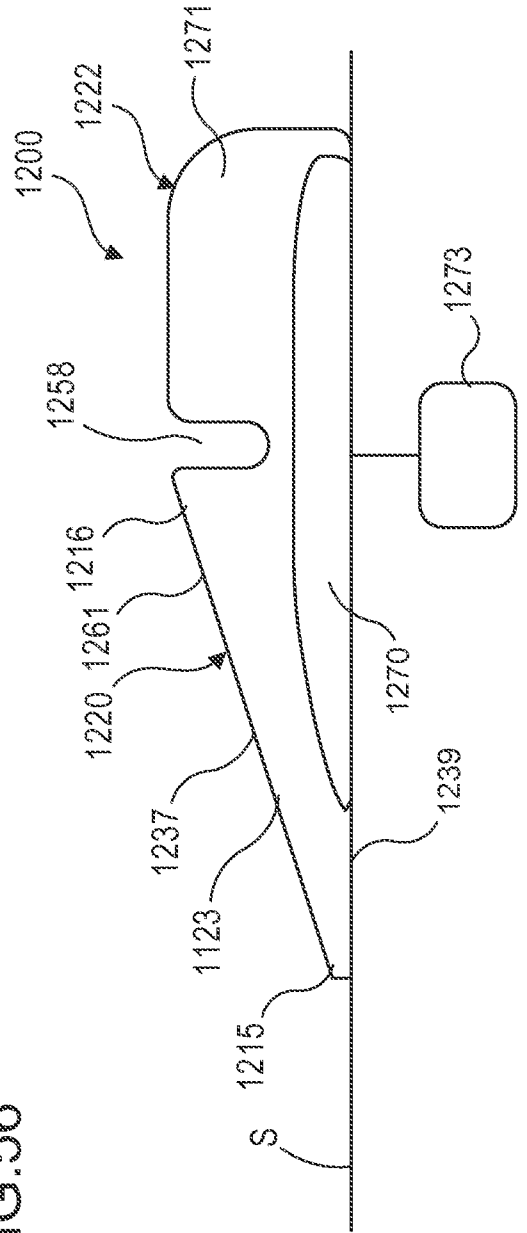

FIG.57

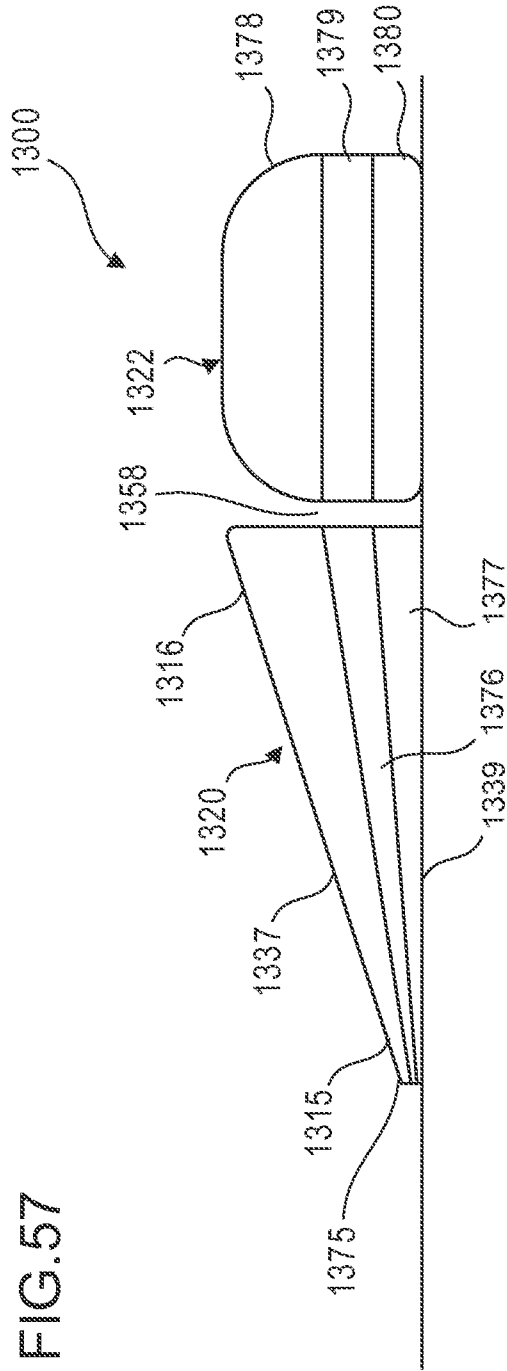
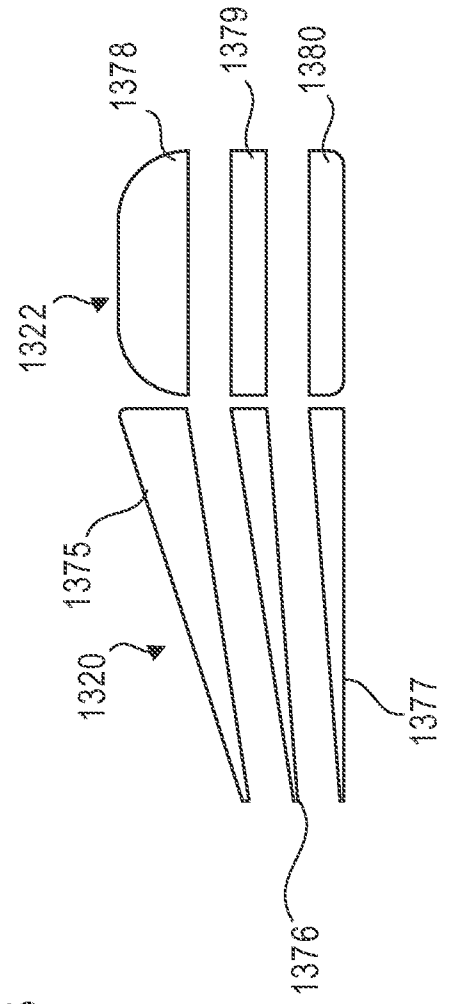

FIG.58



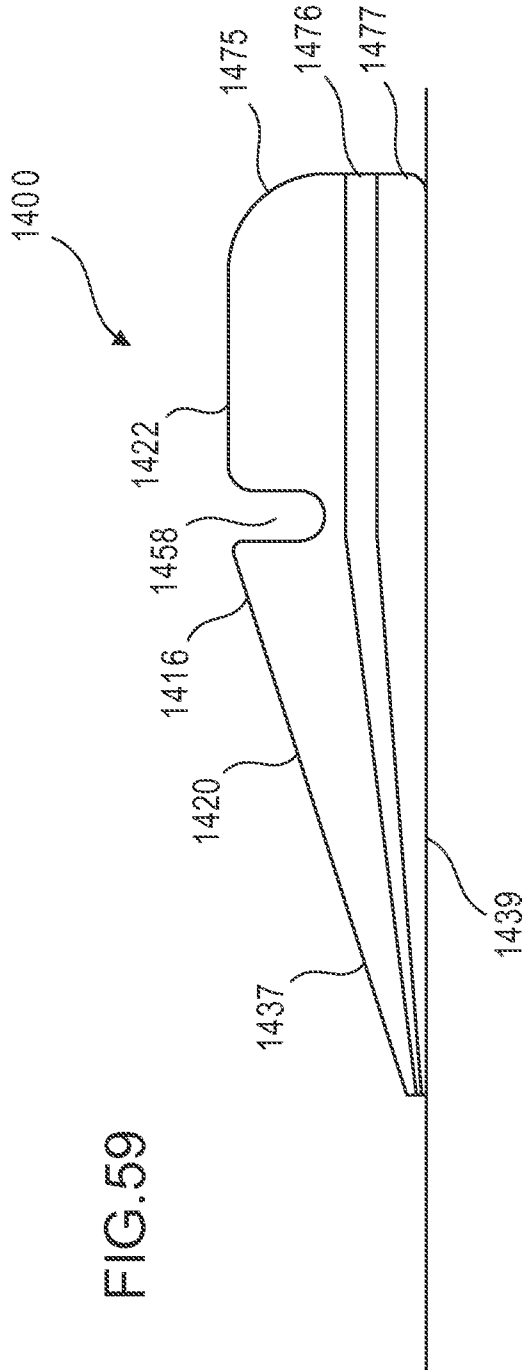

FIG. 59

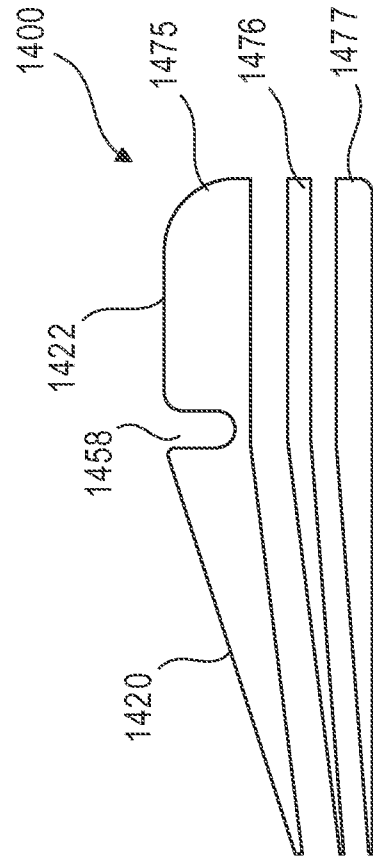

FIG. 60

FIG.61

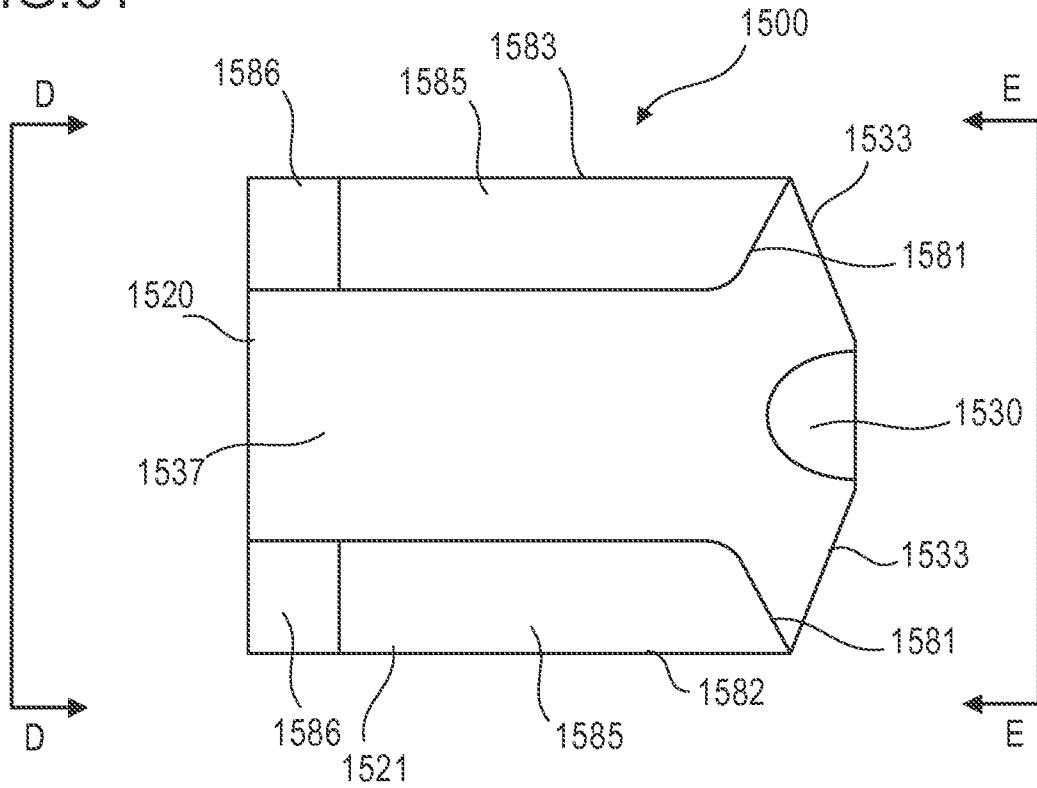

FIG.62

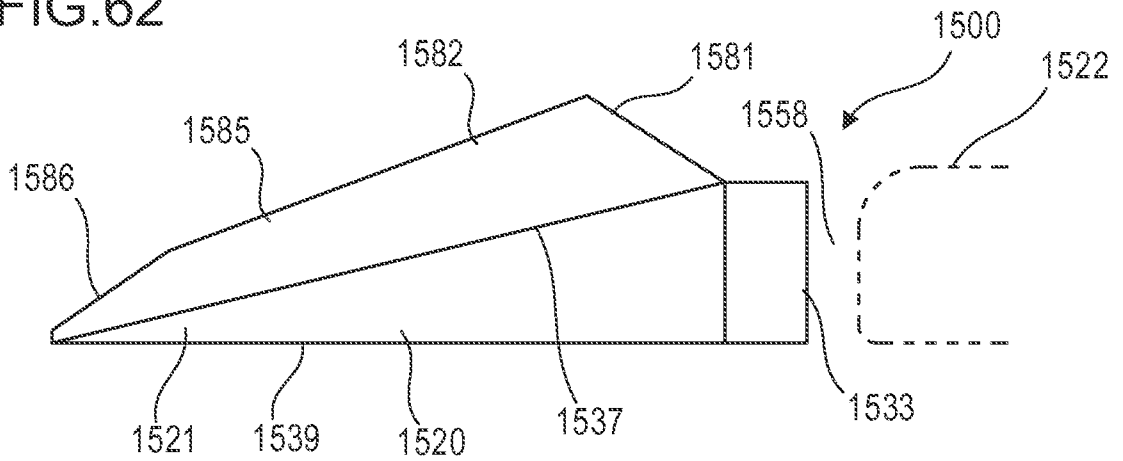

FIG.63

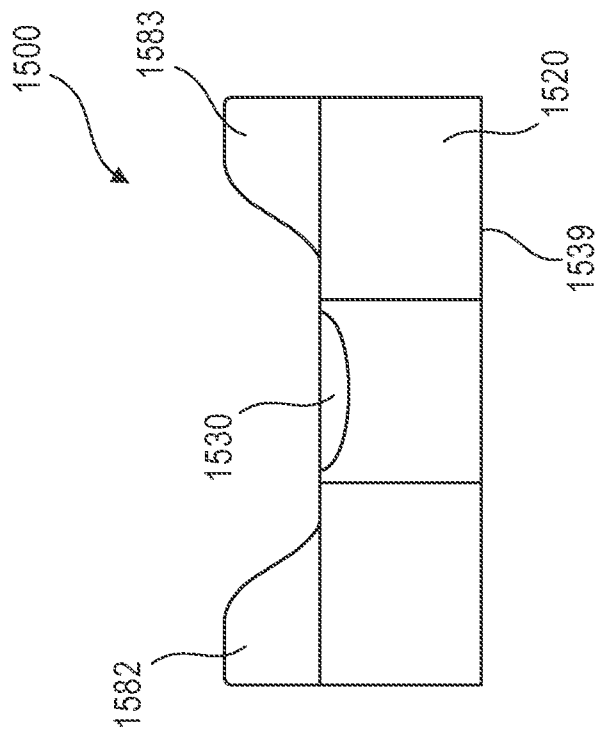
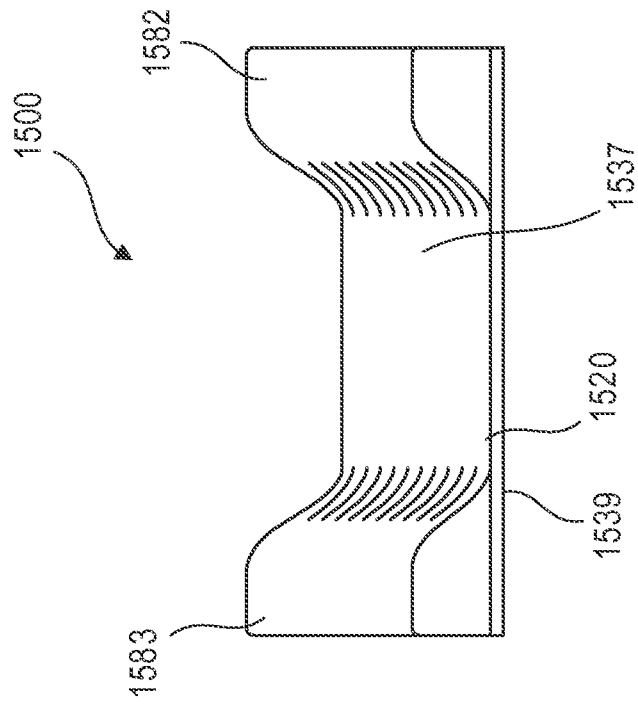

FIG.64



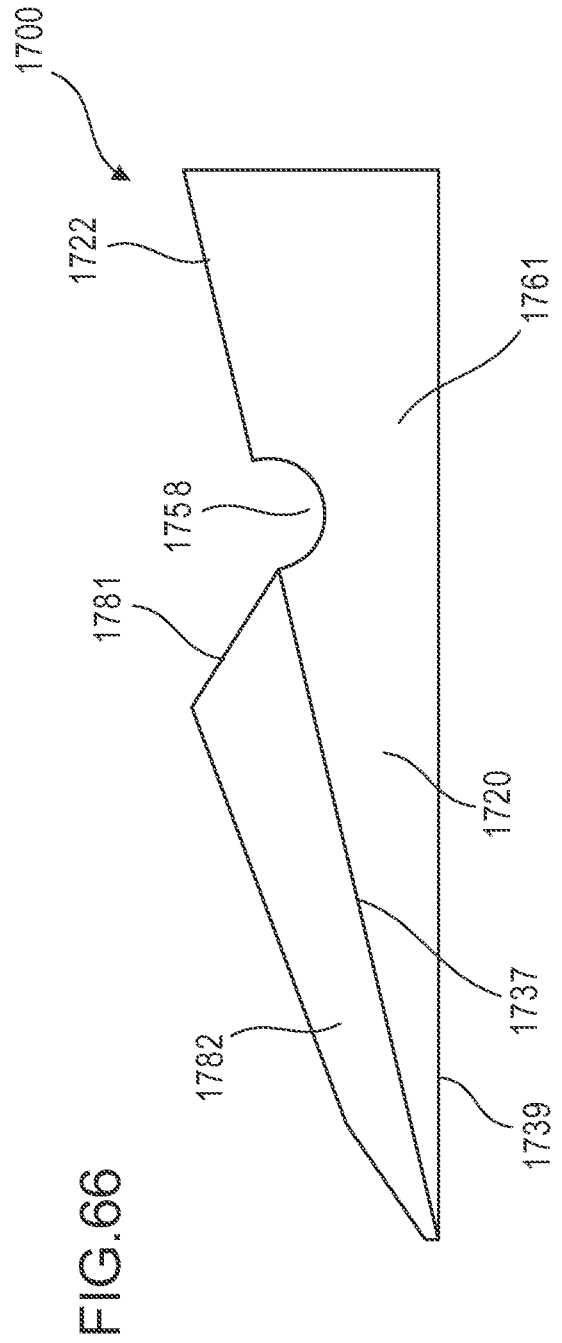
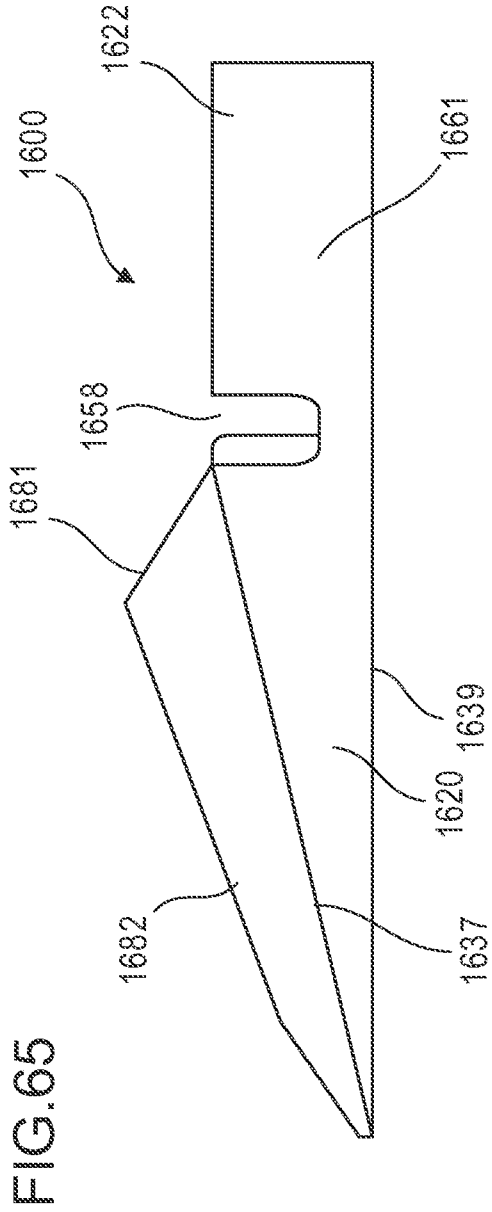

FIG.69

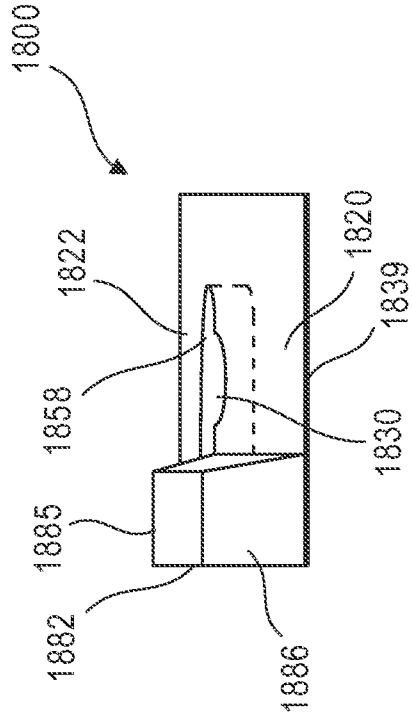

FIG.70

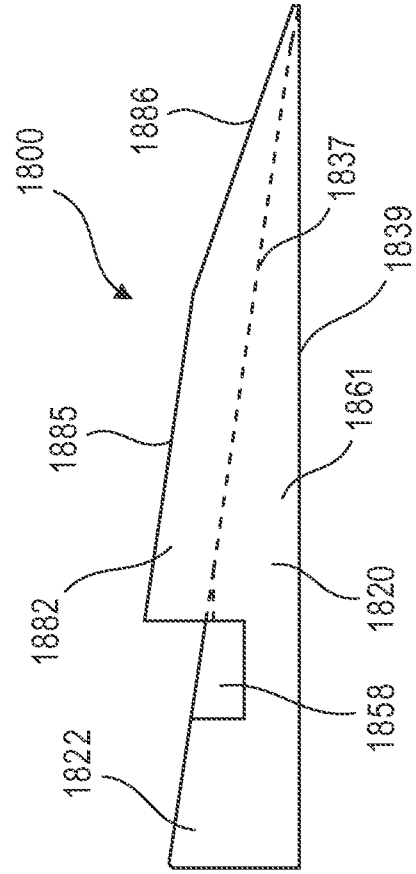

FIG.68

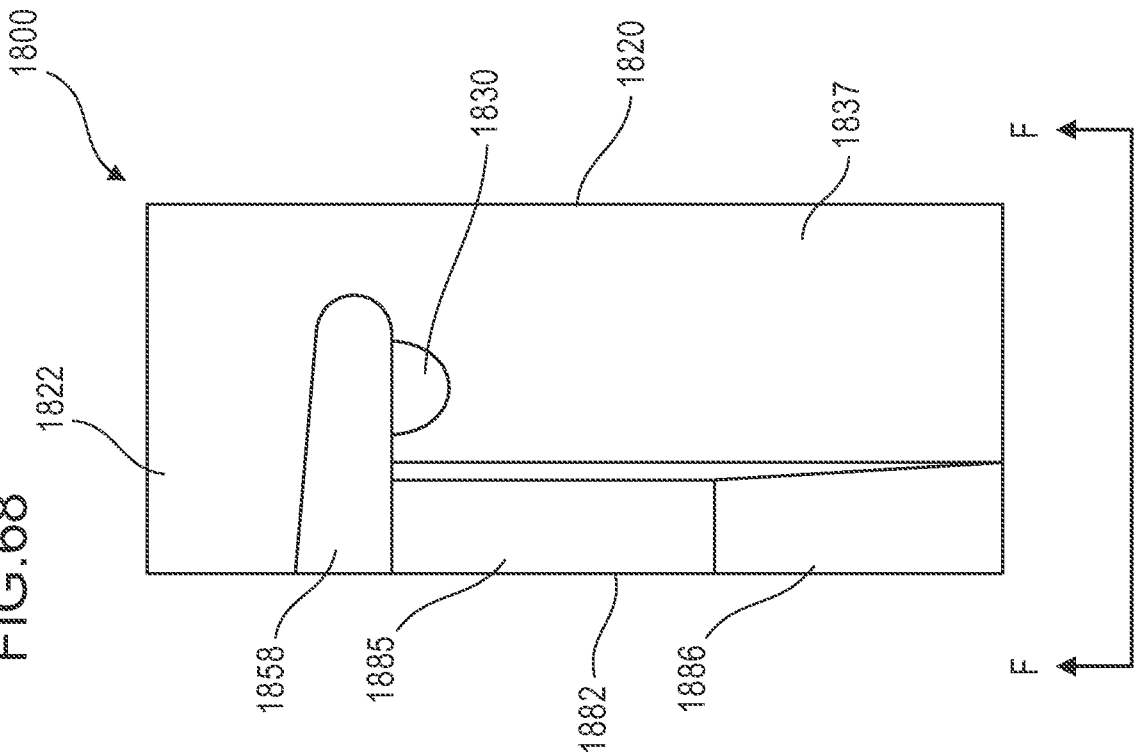

FIG. 71

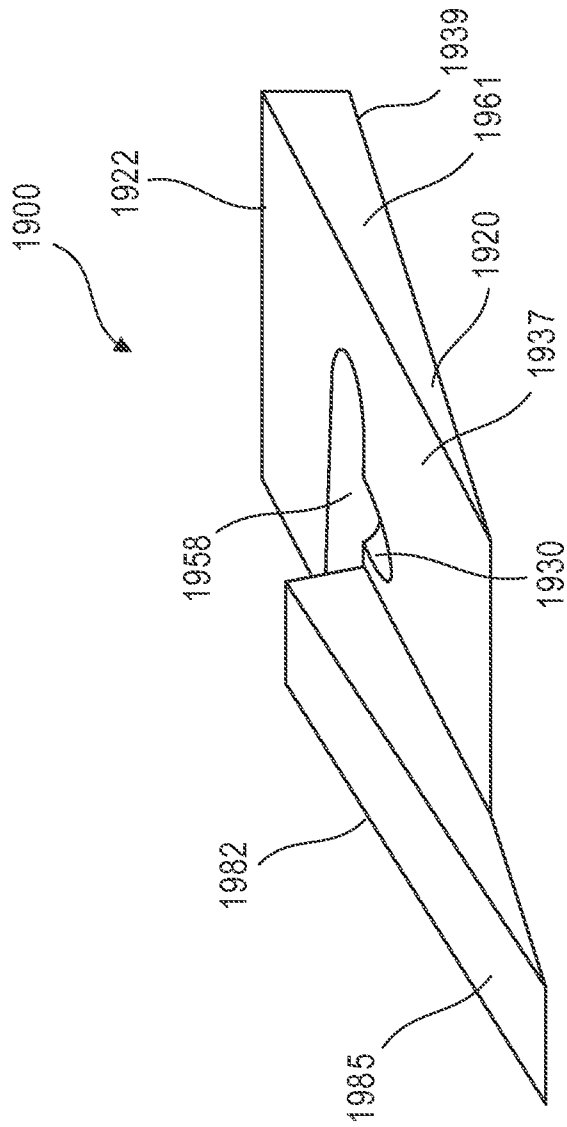

FIG.73

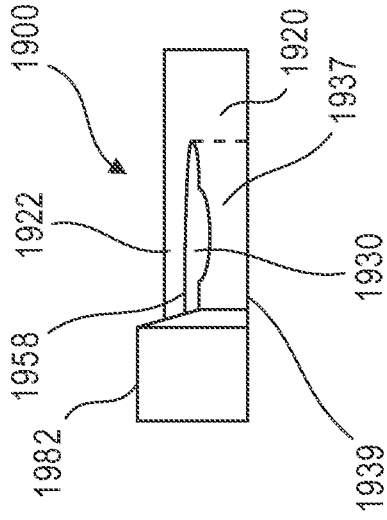
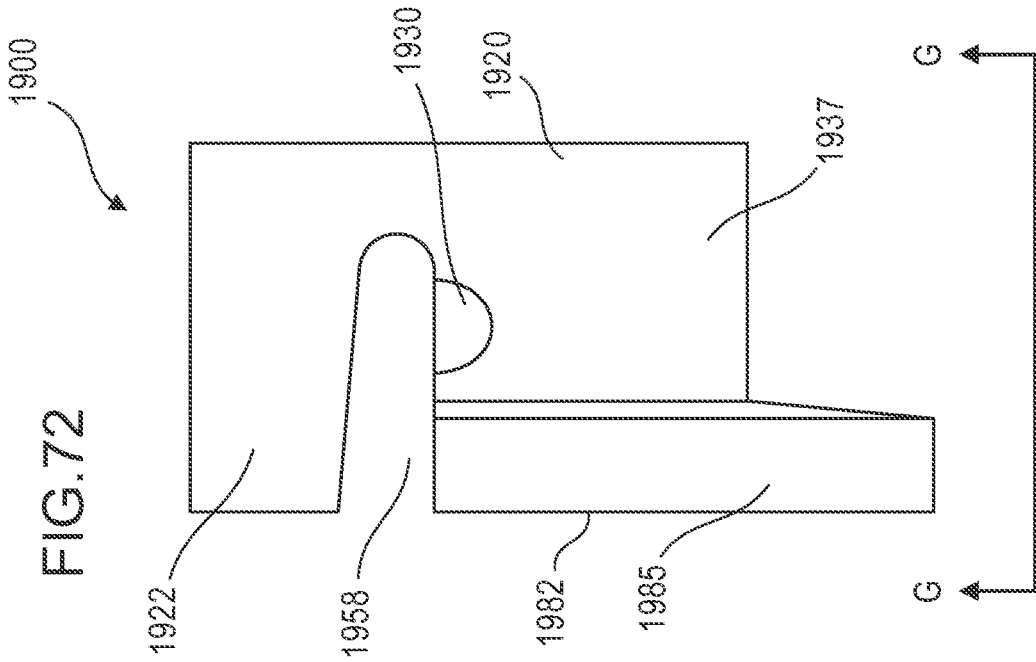
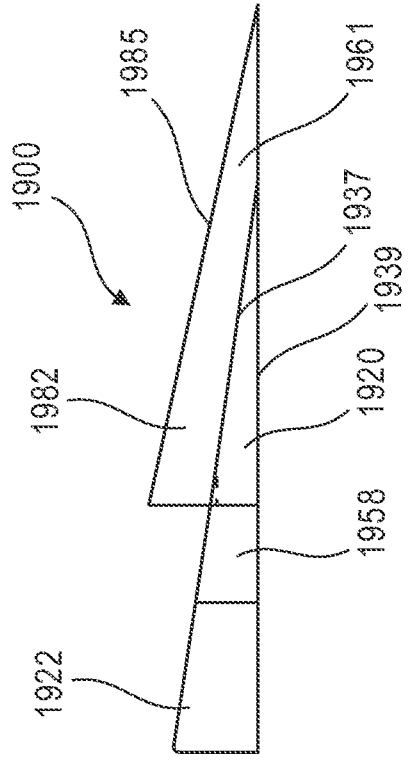

FIG.74



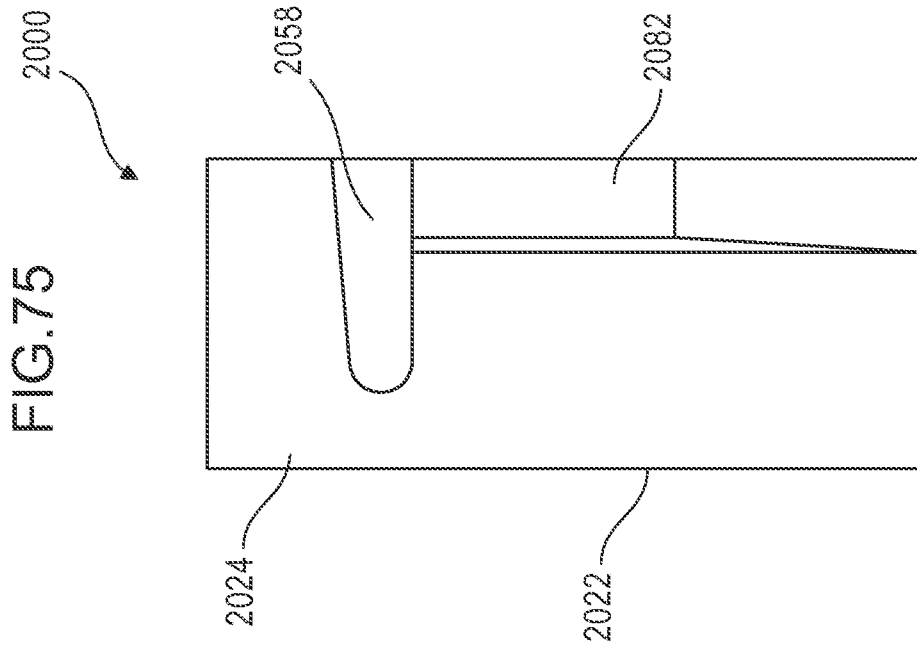

FIG.77

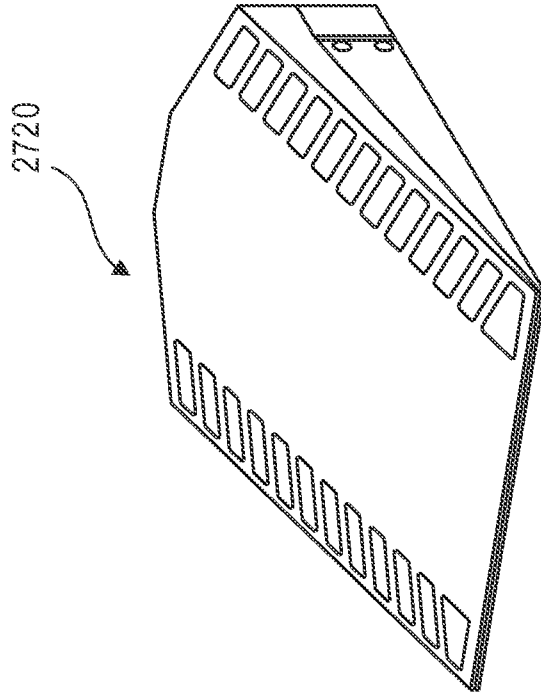

FIG.76

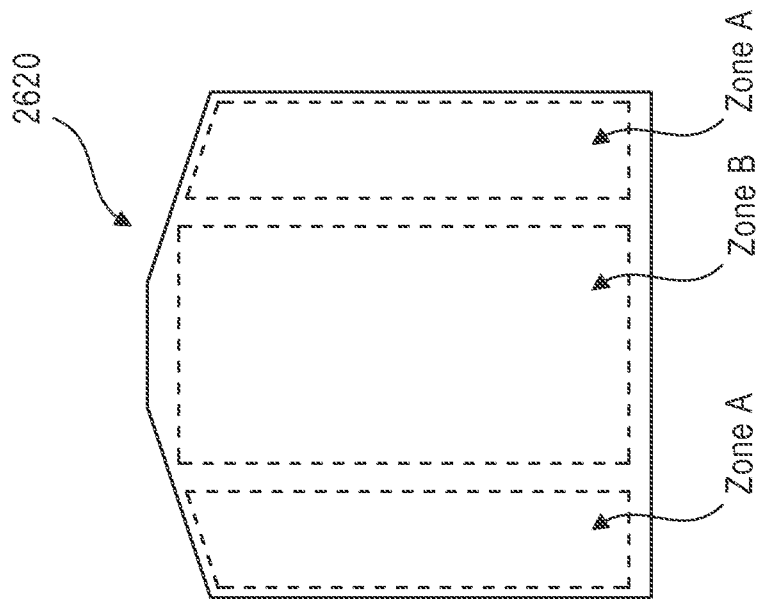

FIG.78

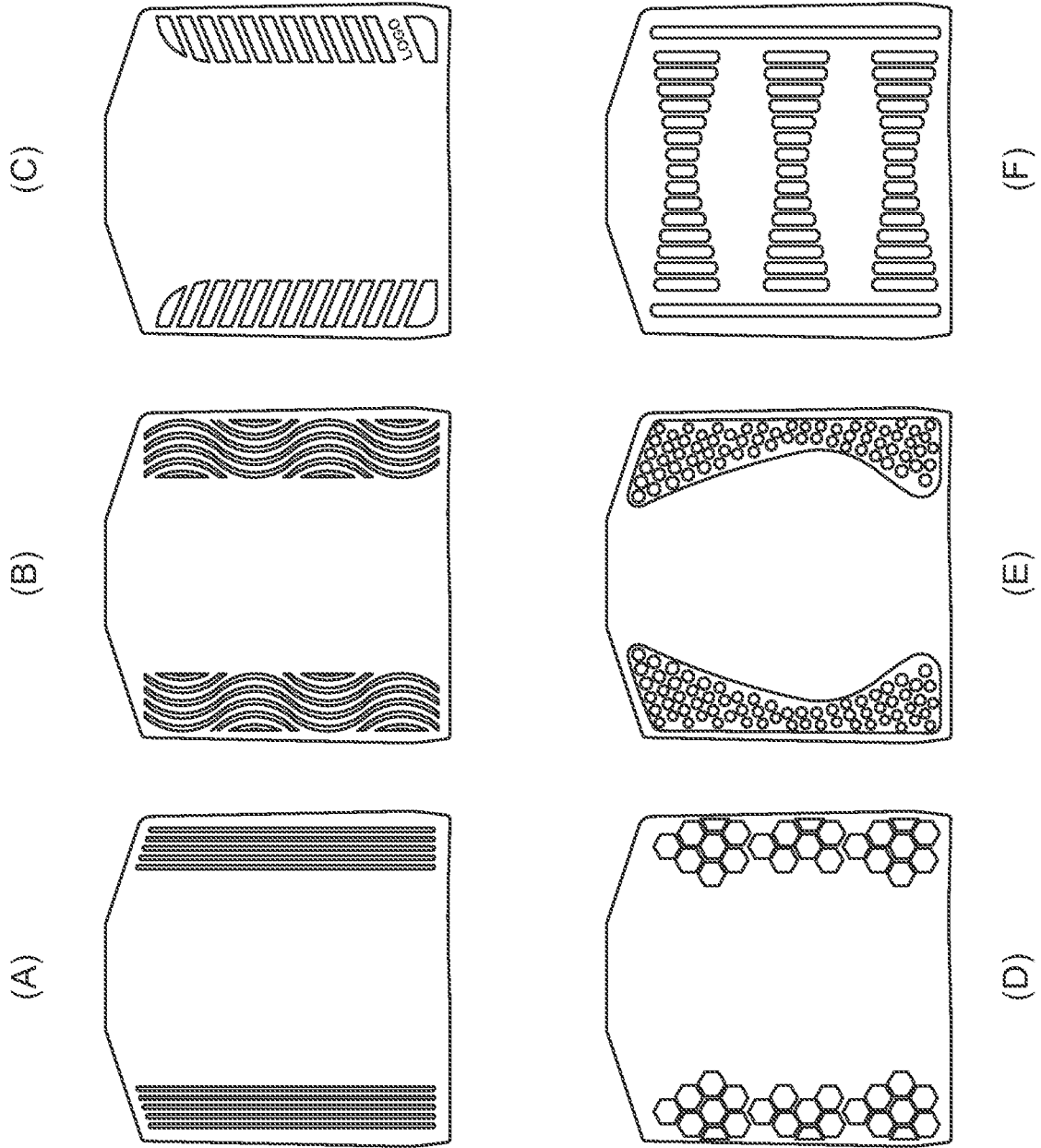

FIG. 79

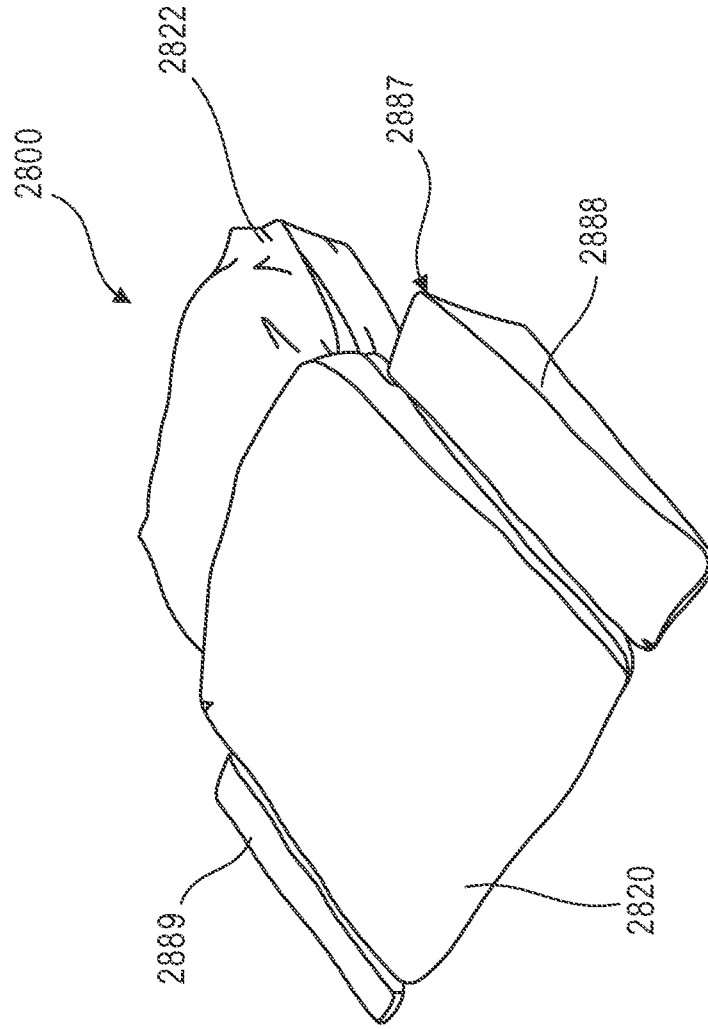
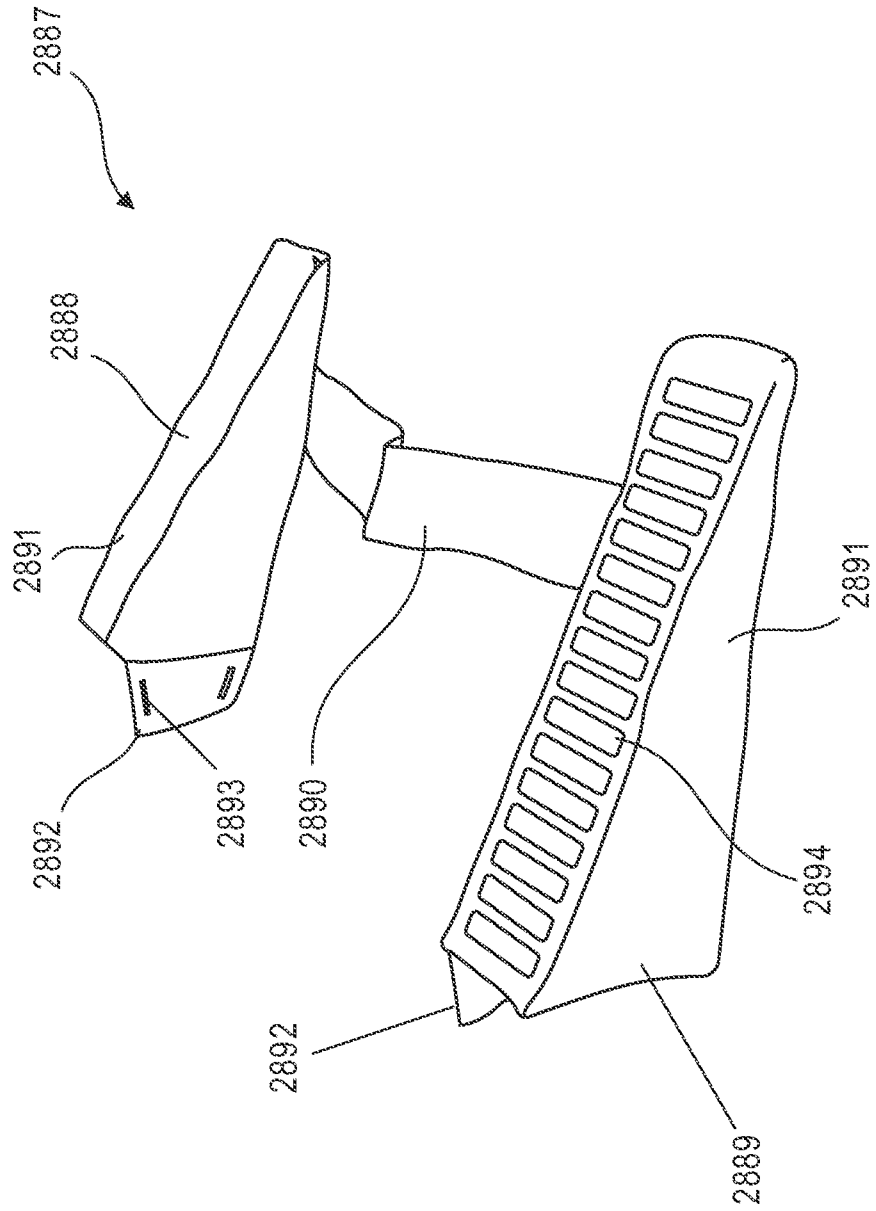

FIG. 80



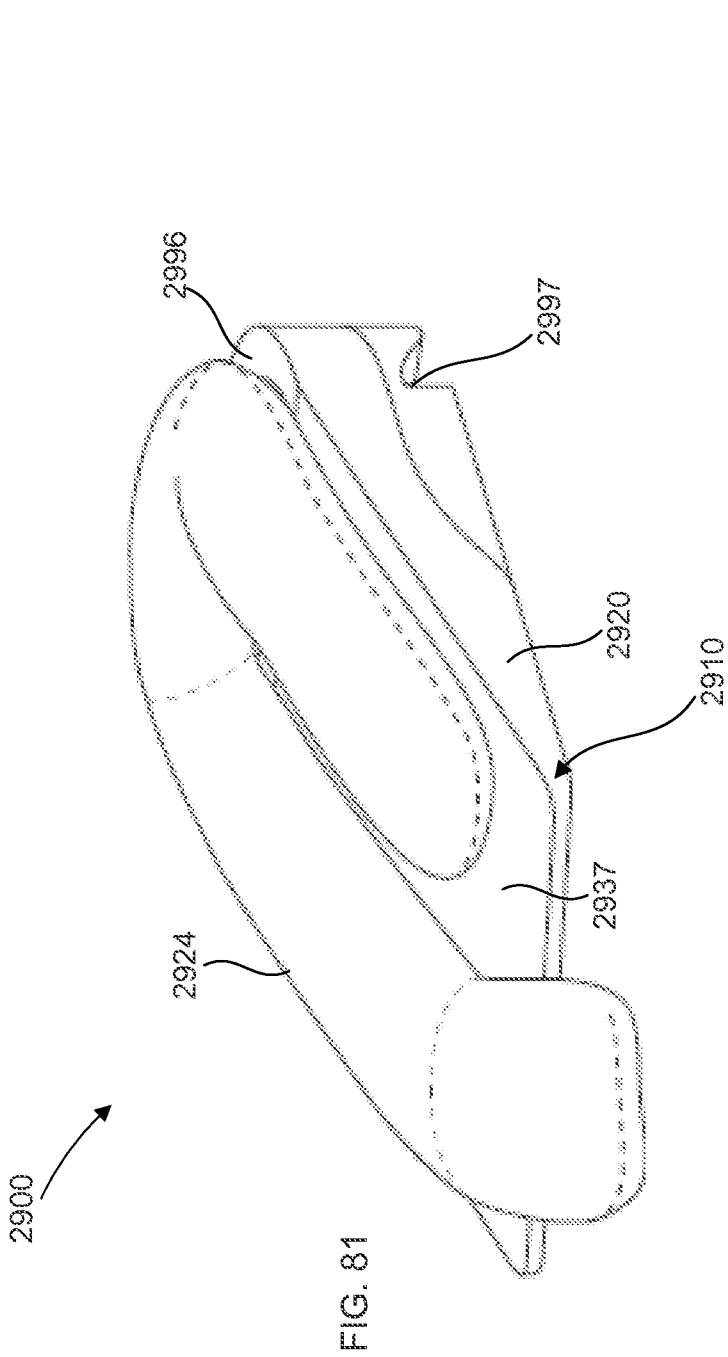

FIG. 81

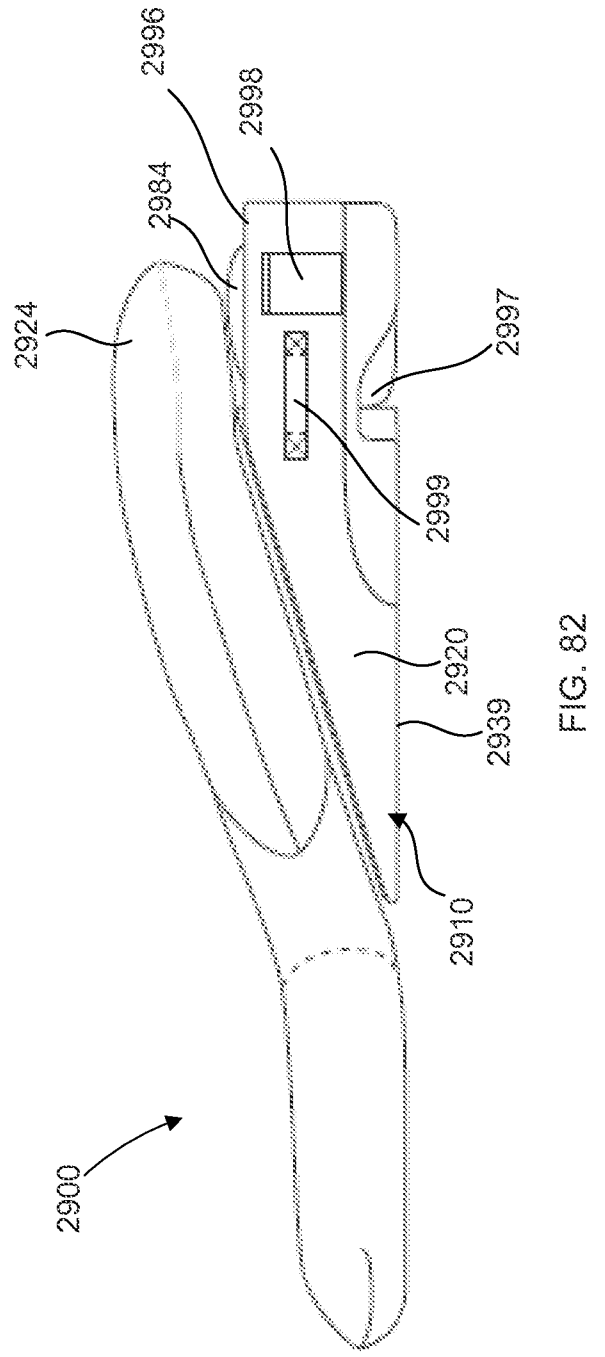
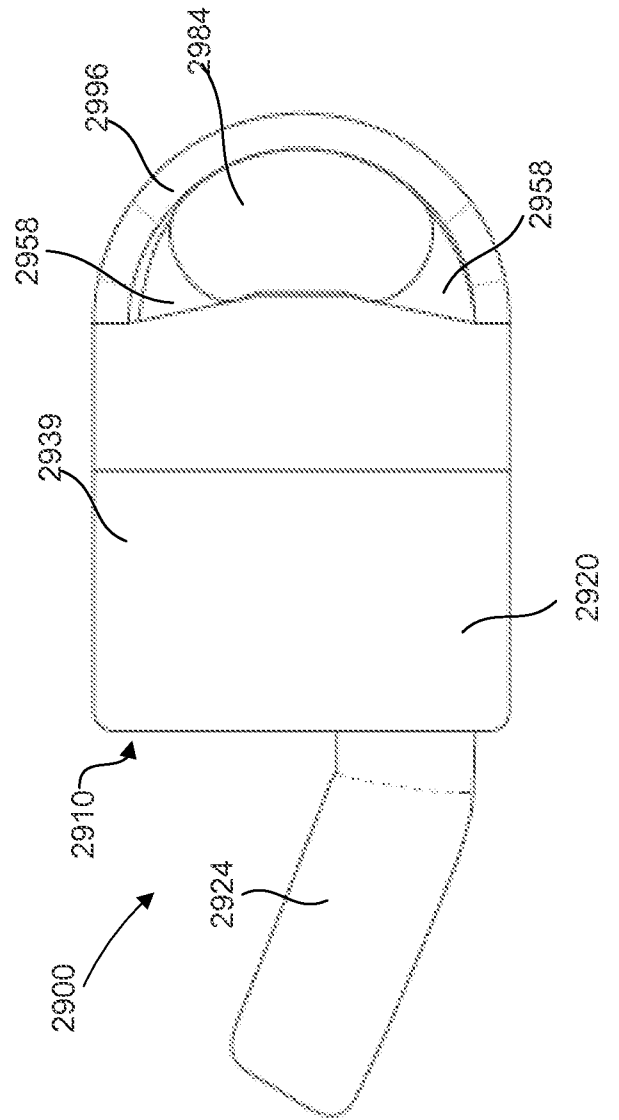
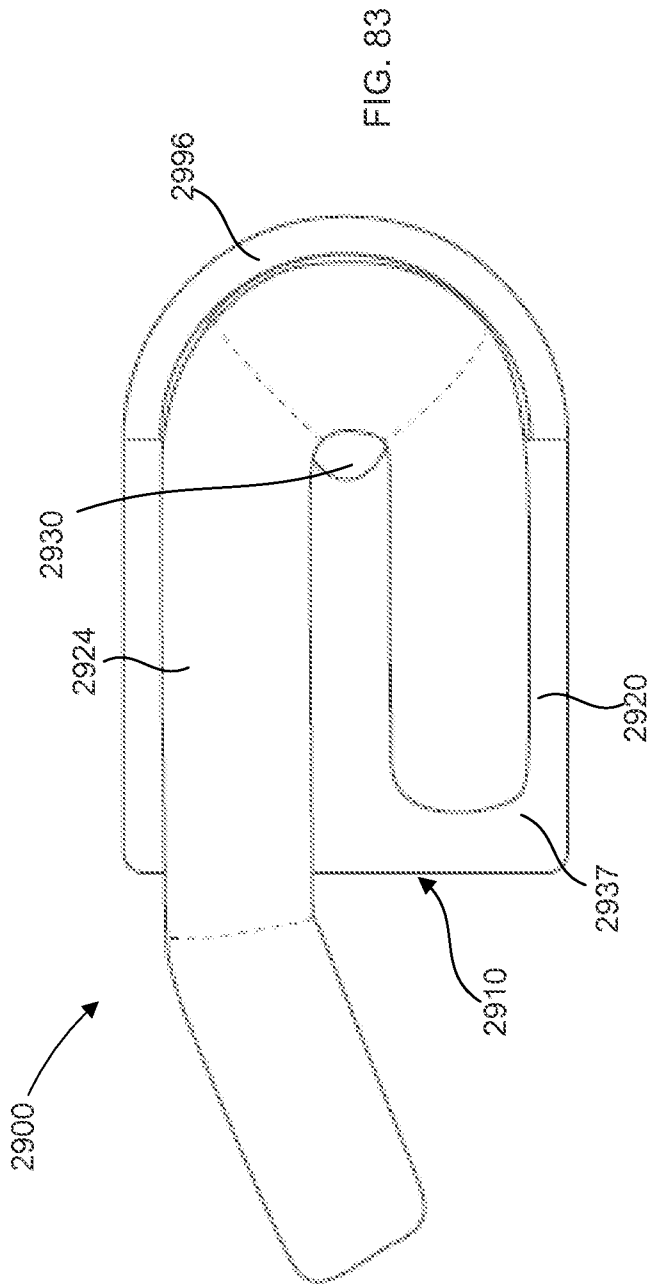

FIG. 82



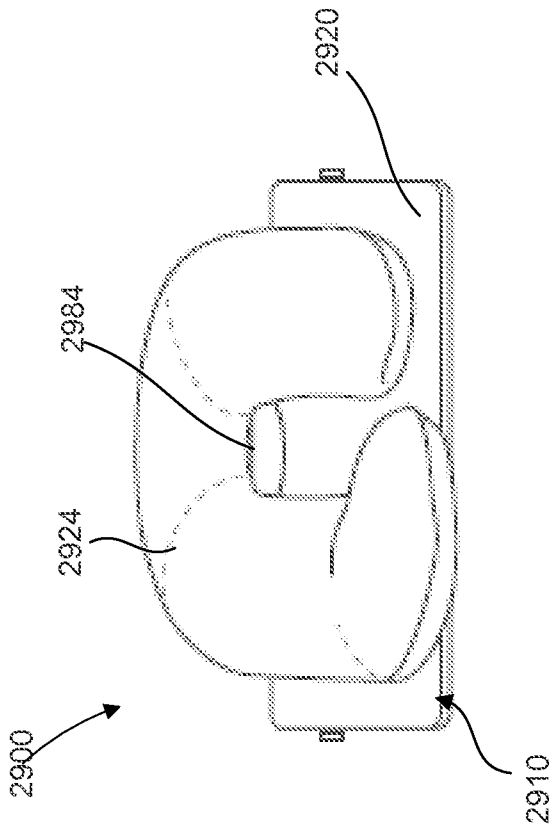

FIG. 85

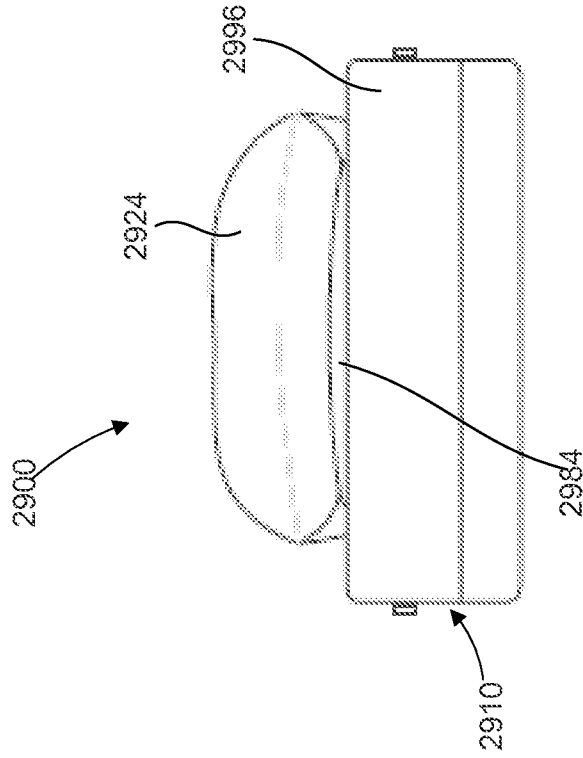

FIG. 86

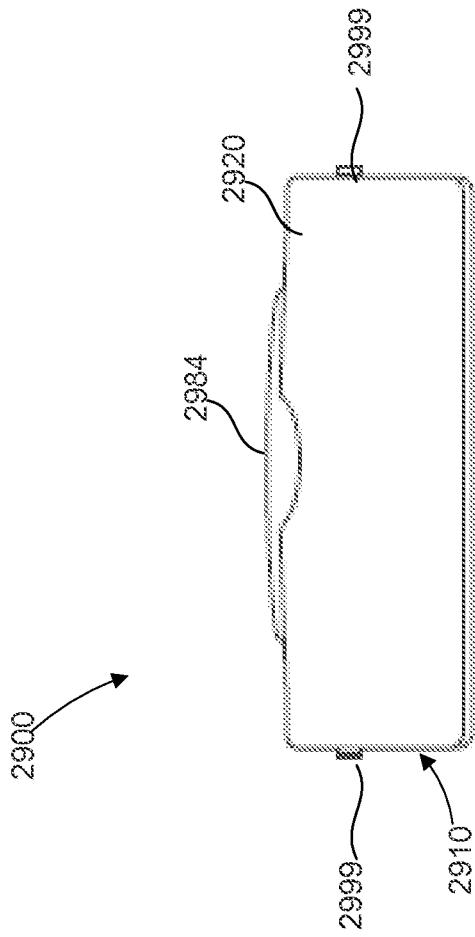

FIG. 88

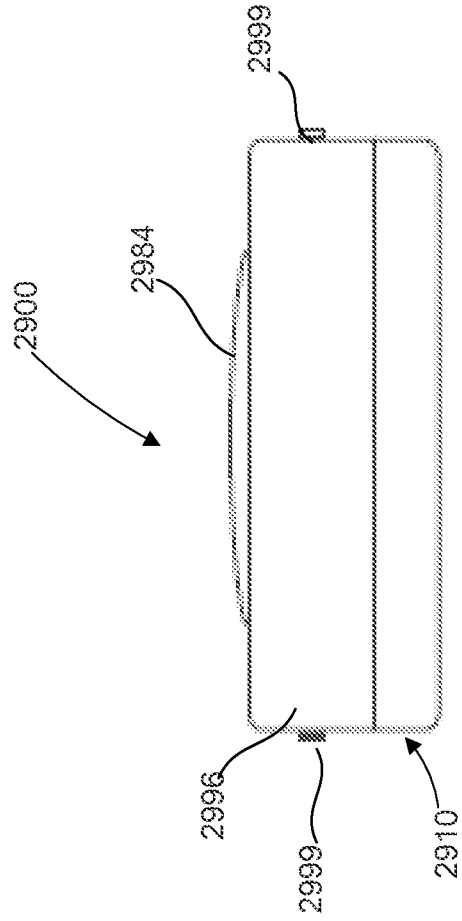

FIG. 89

49/72

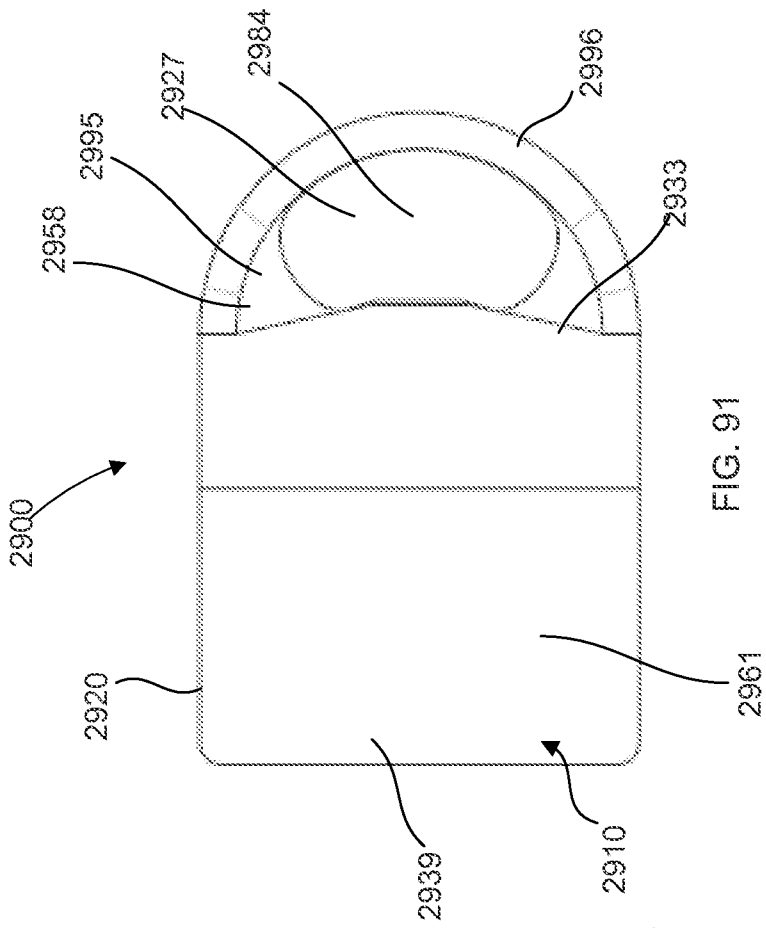

FIG. 91

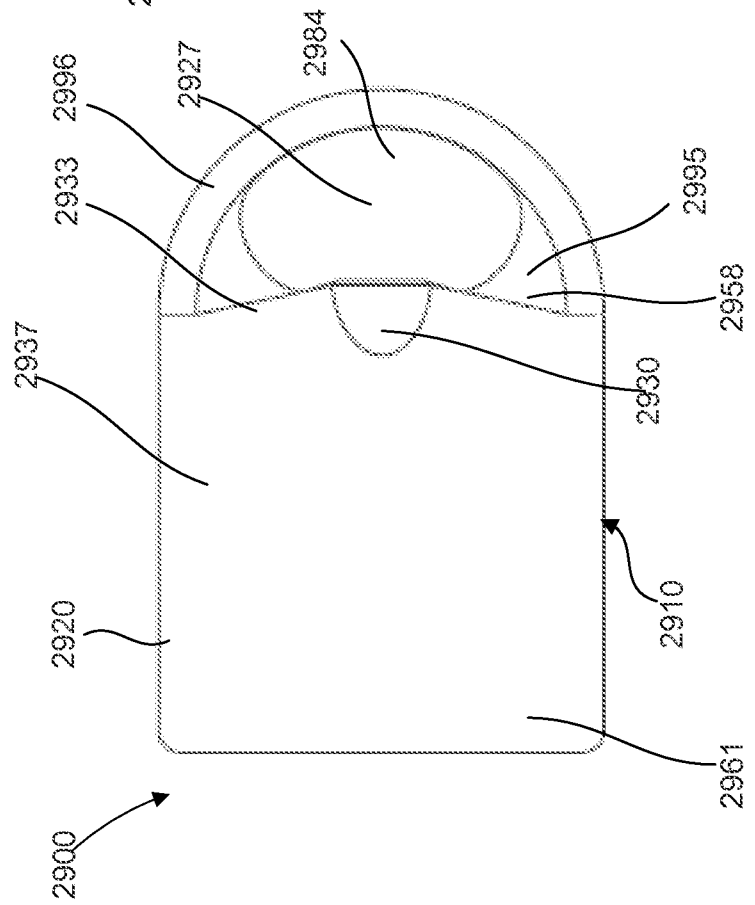

FIG. 90

50/72

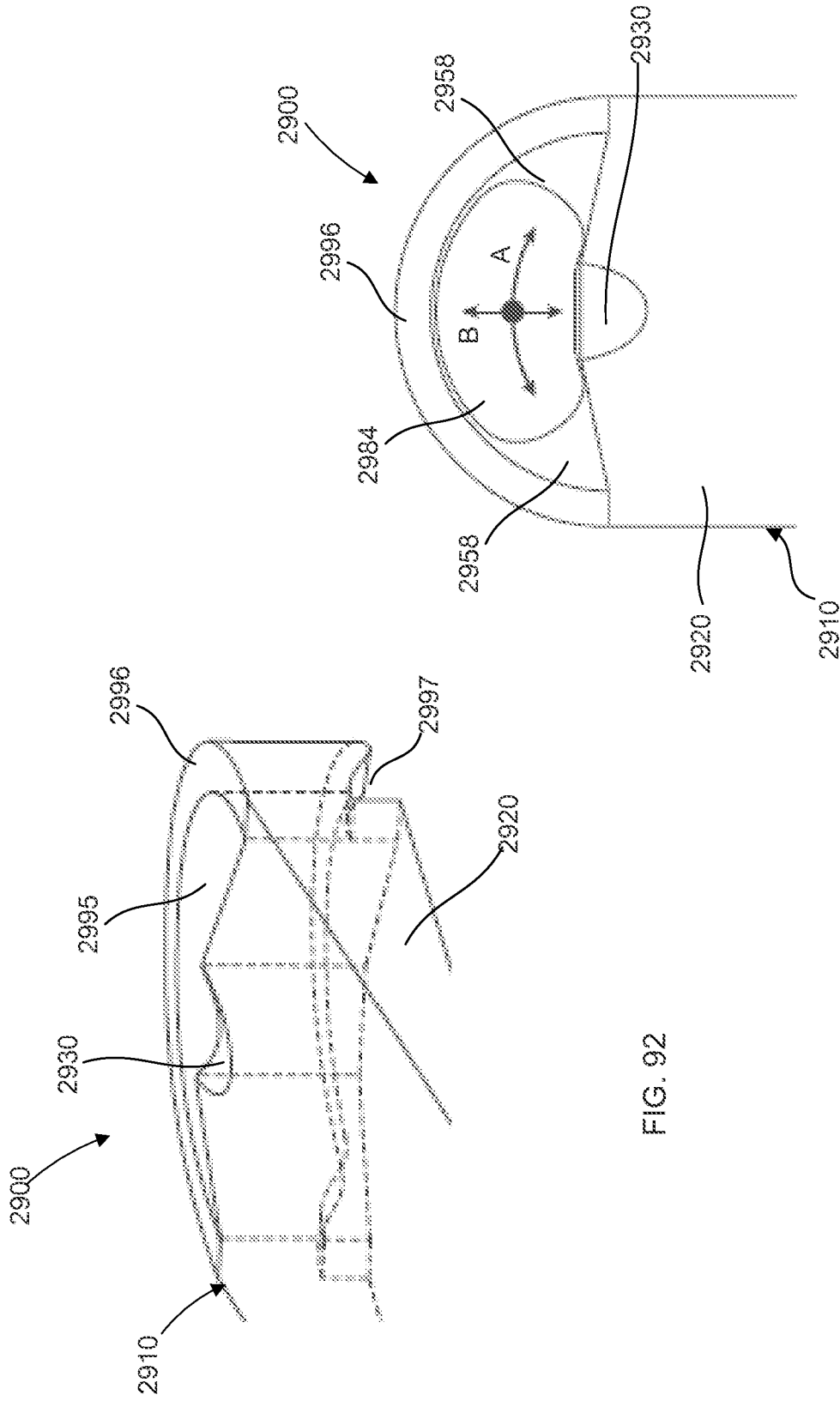

FIG. 92

FIG. 93

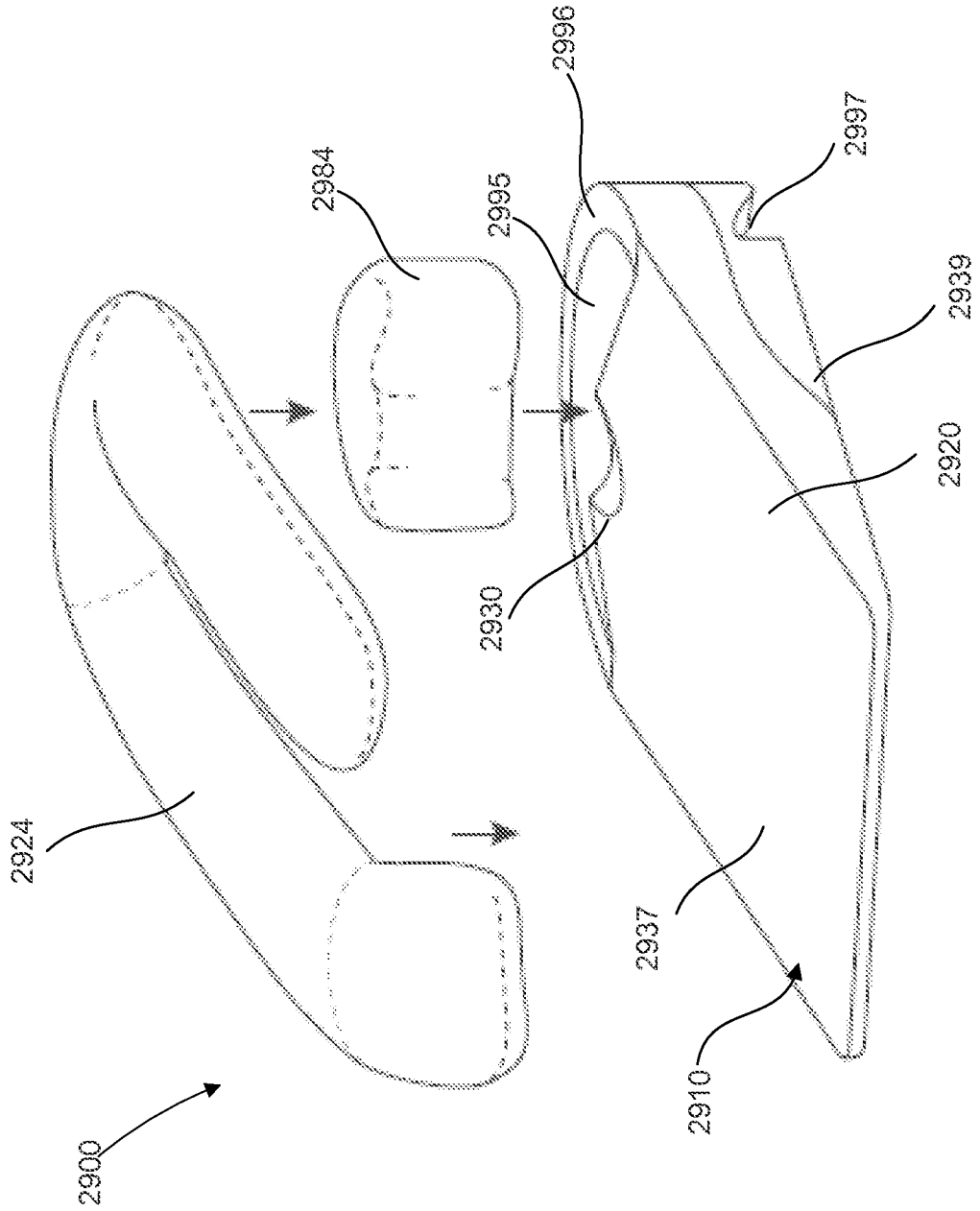

FIG. 94

52/72

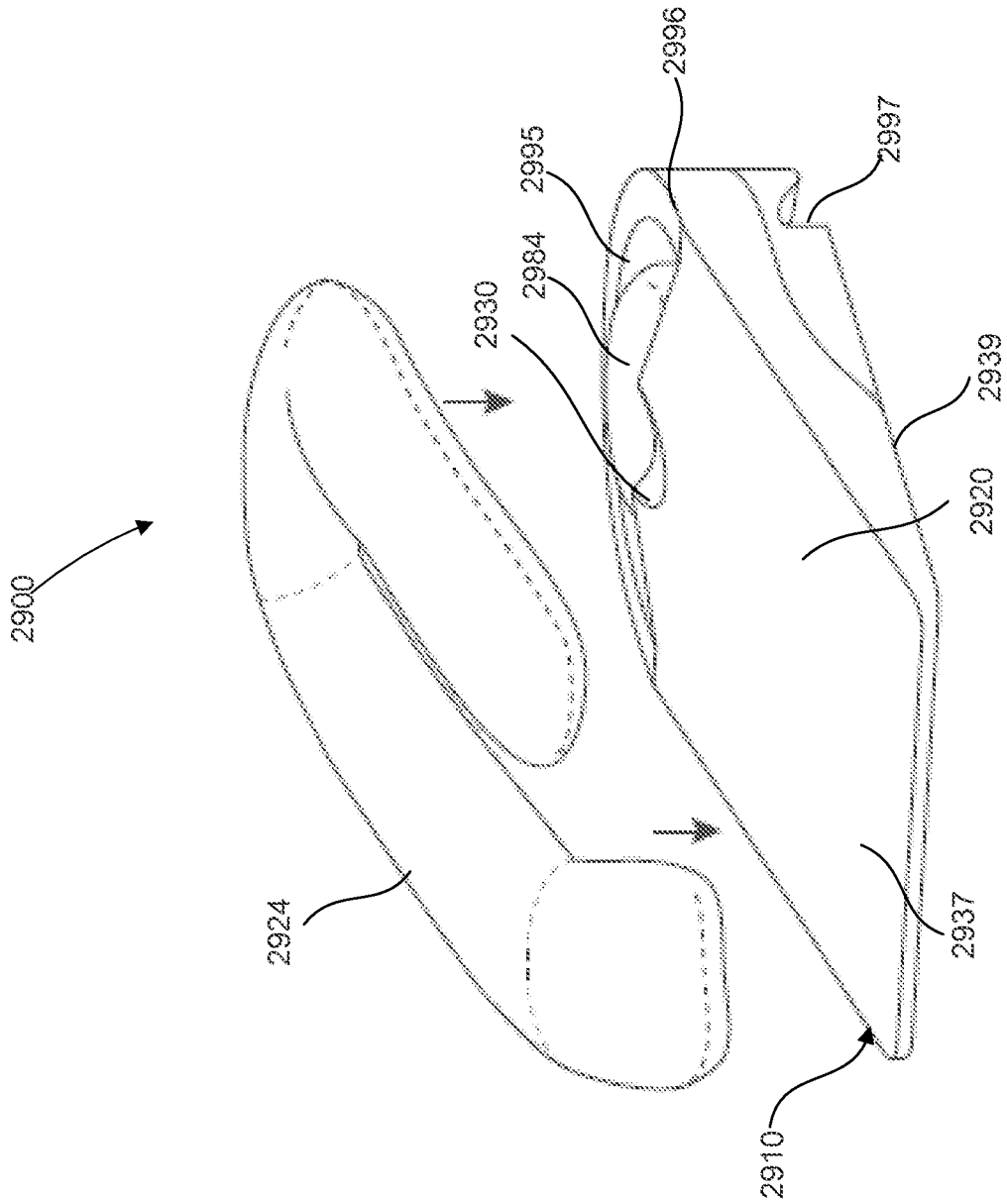

FIG. 95

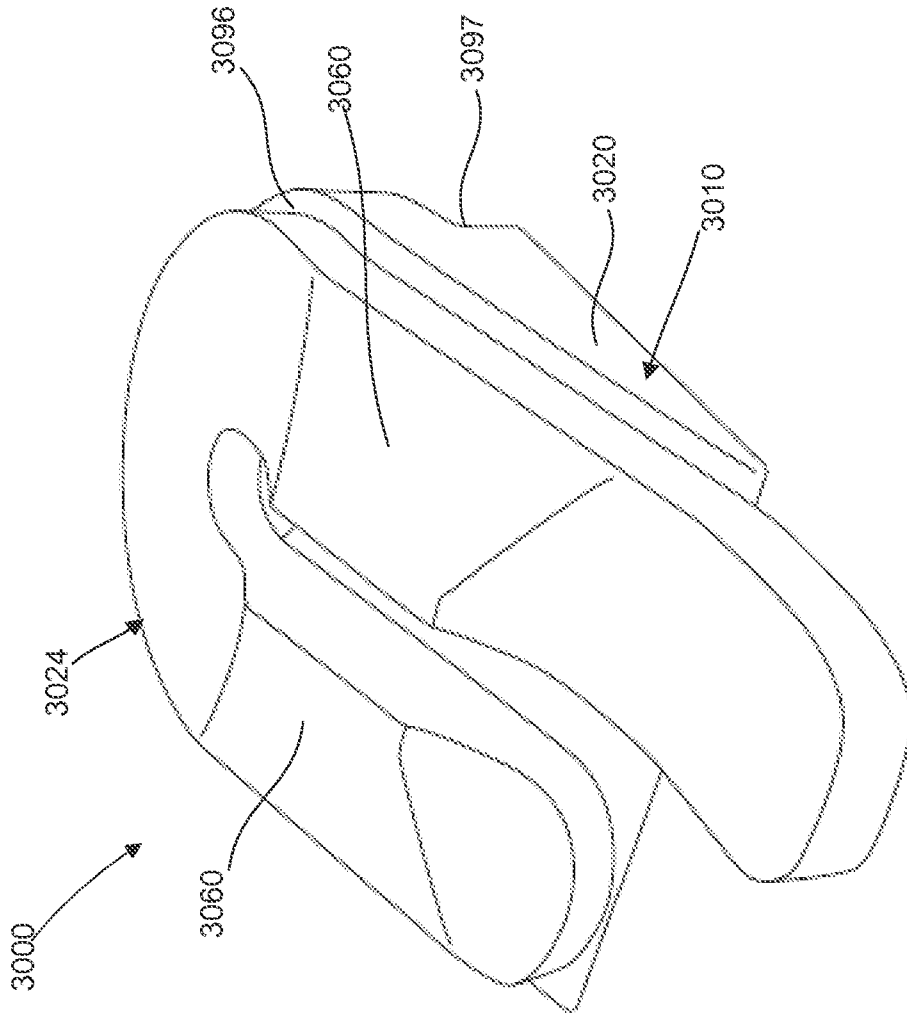

FIG. 96

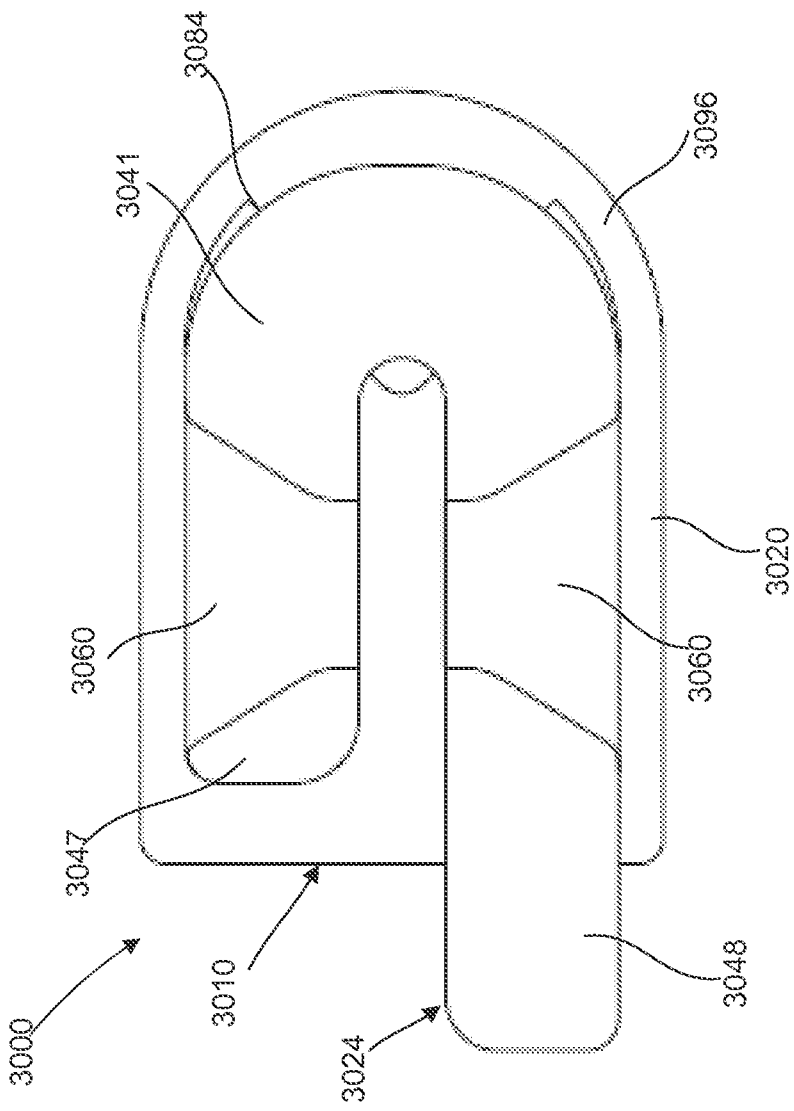

FIG. 97

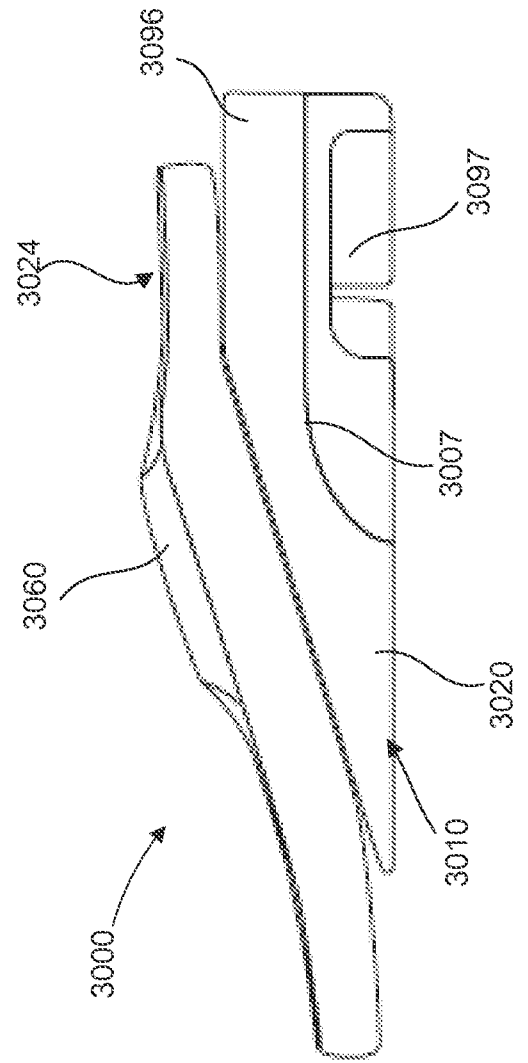

FIG. 98

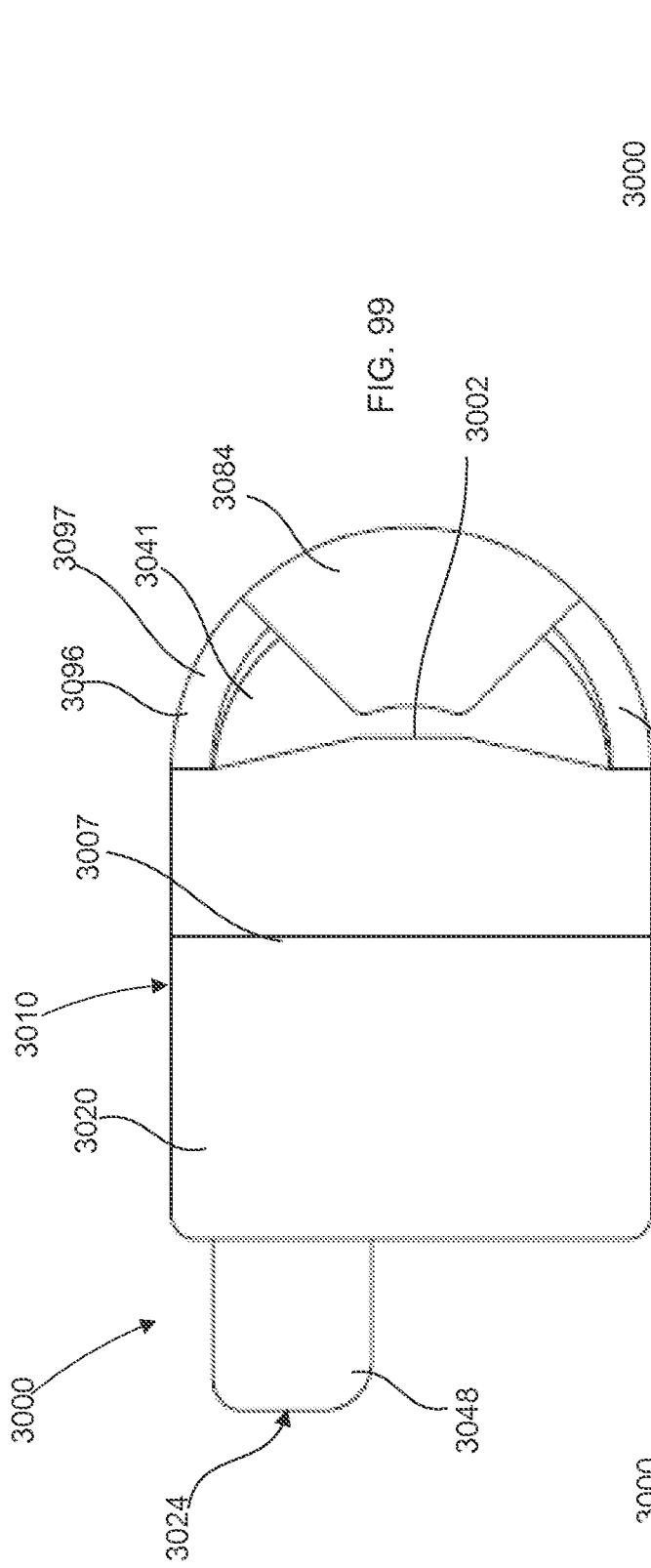

FIG. 99

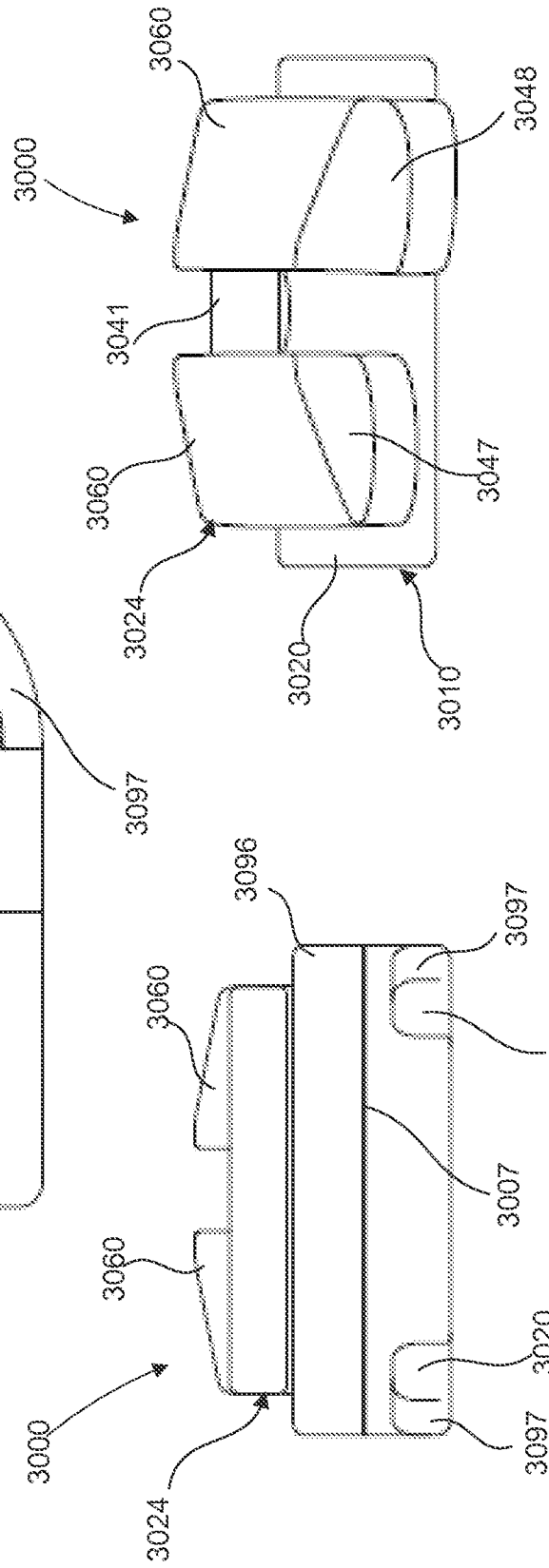

FIG. 101

FIG. 100

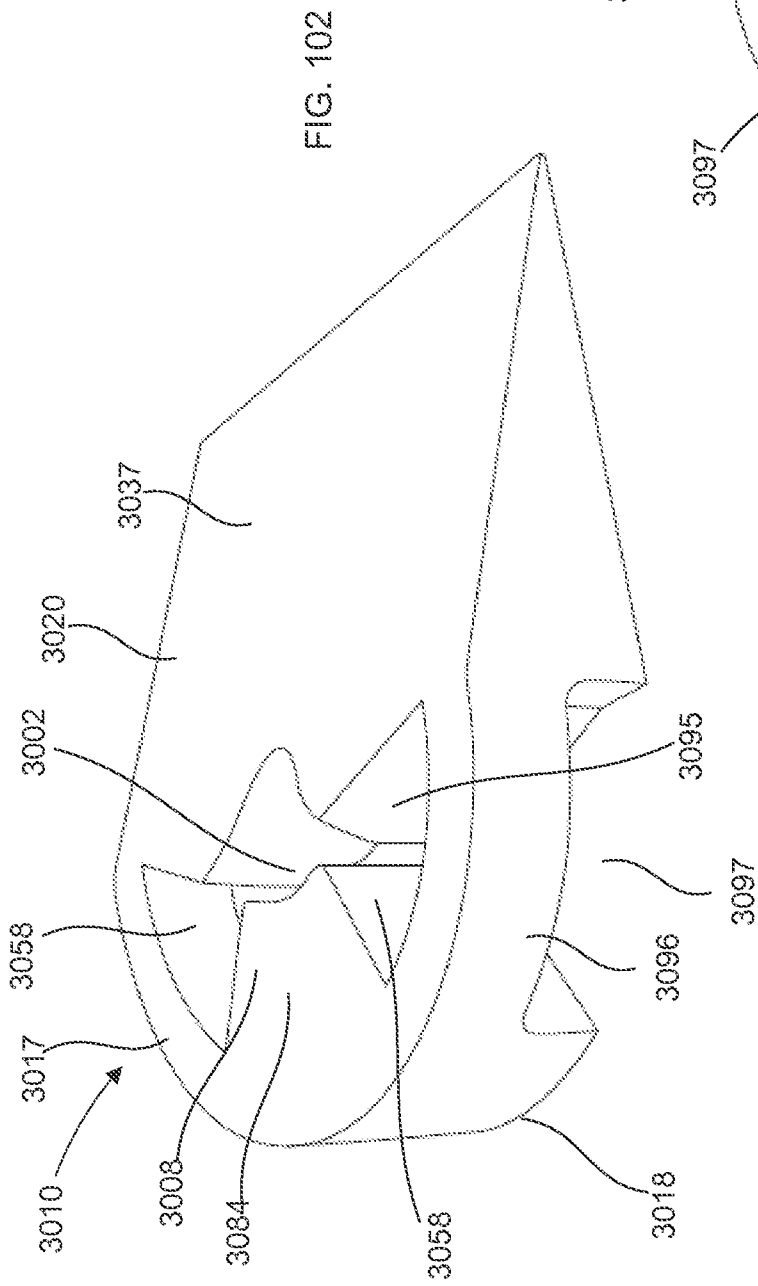

FIG. 102

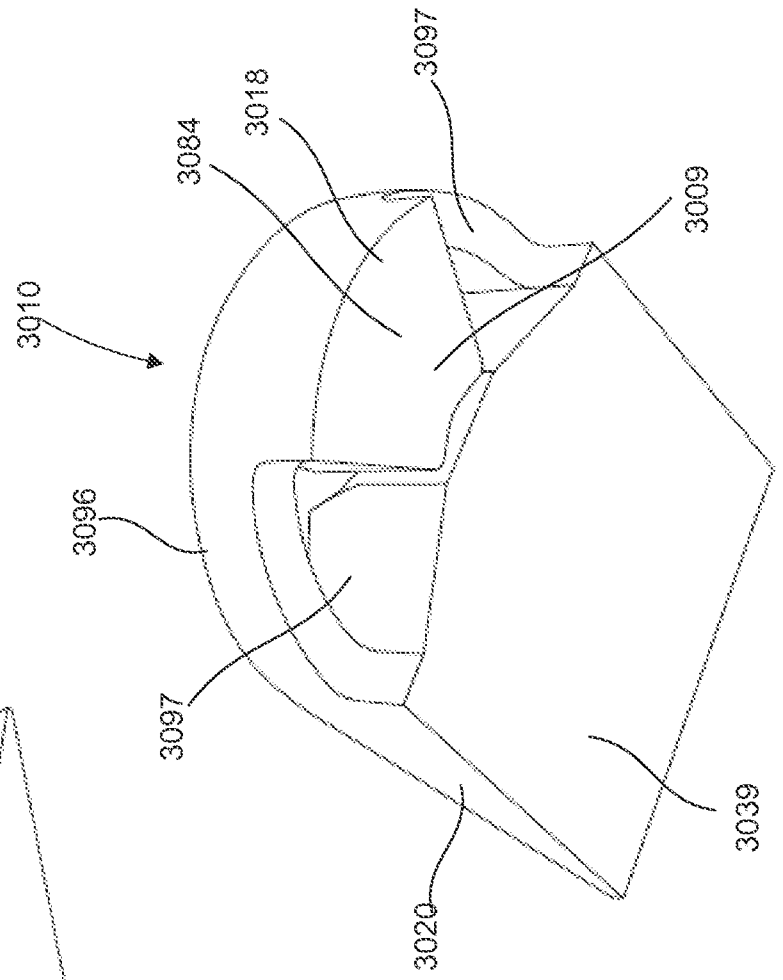
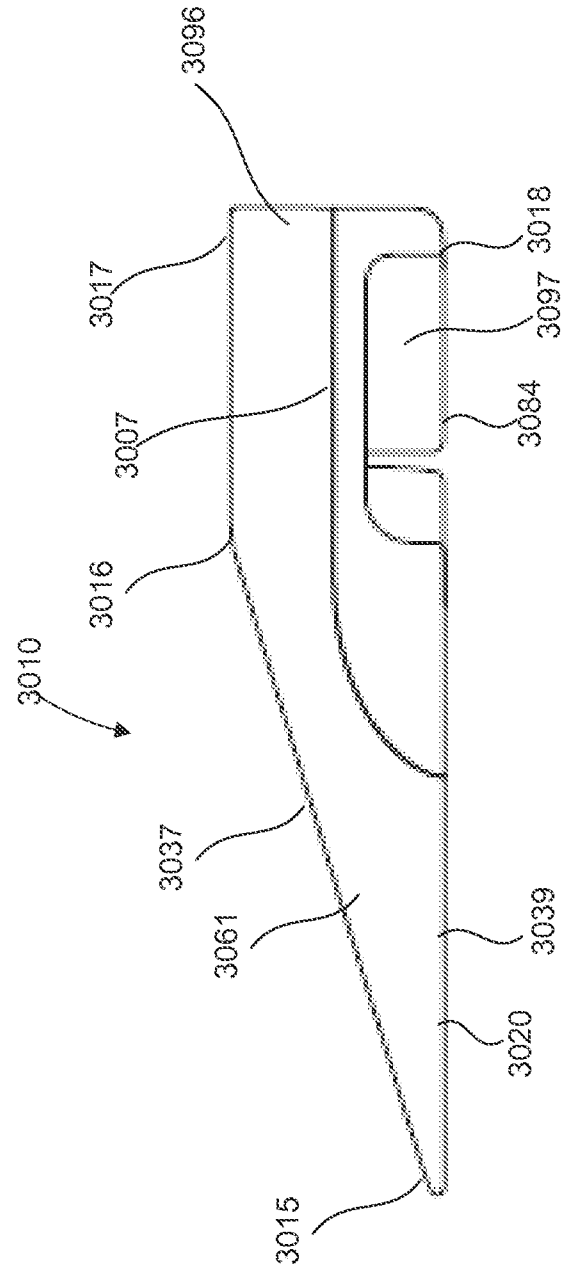
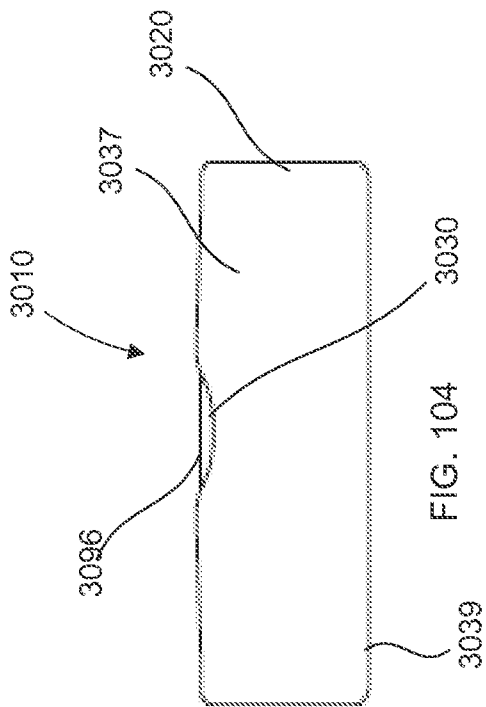
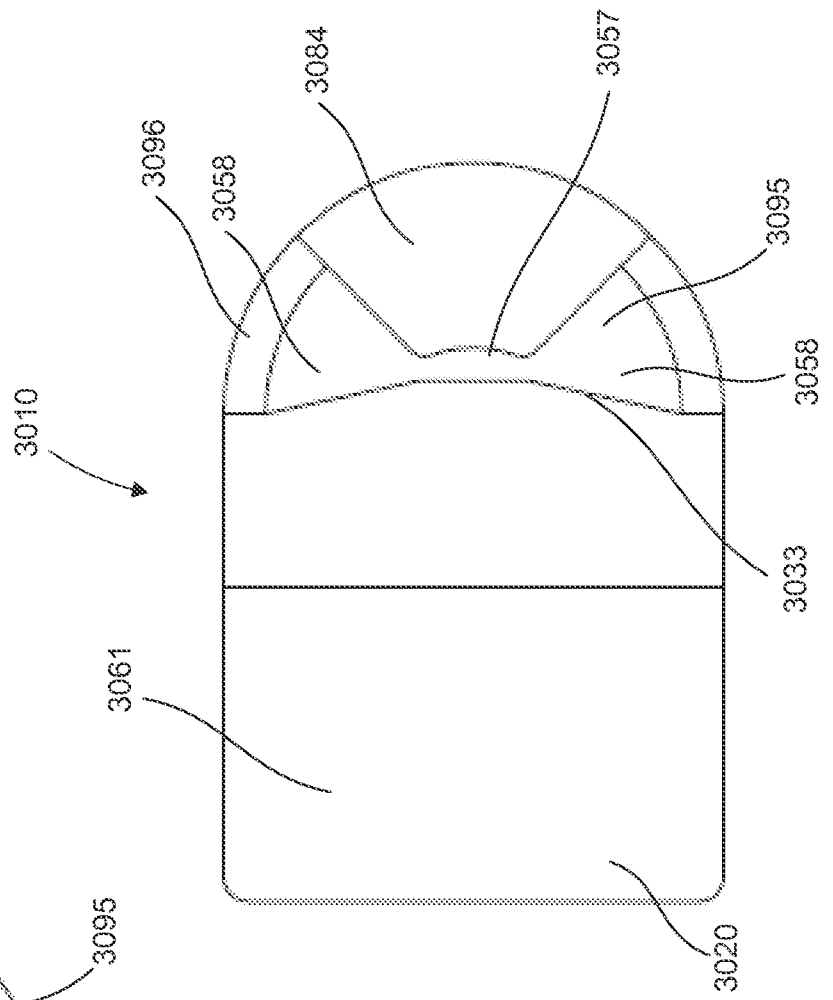
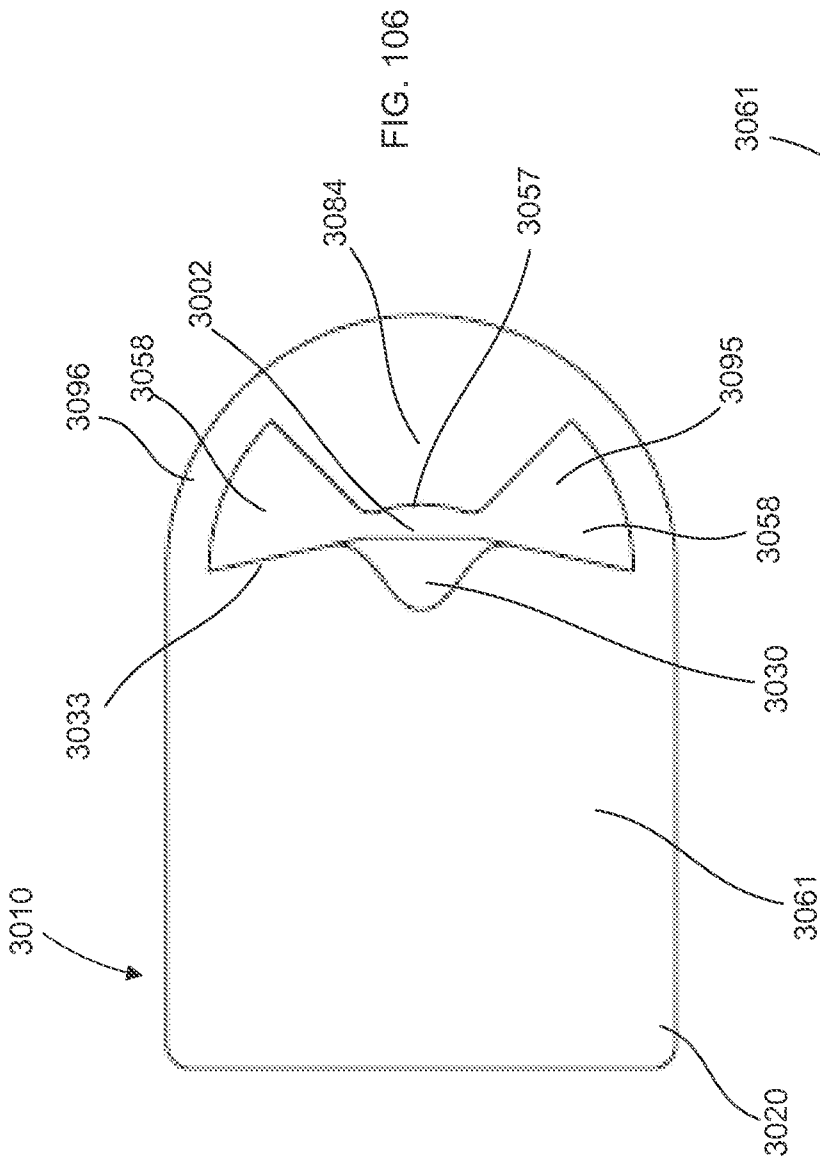

FIG. 103





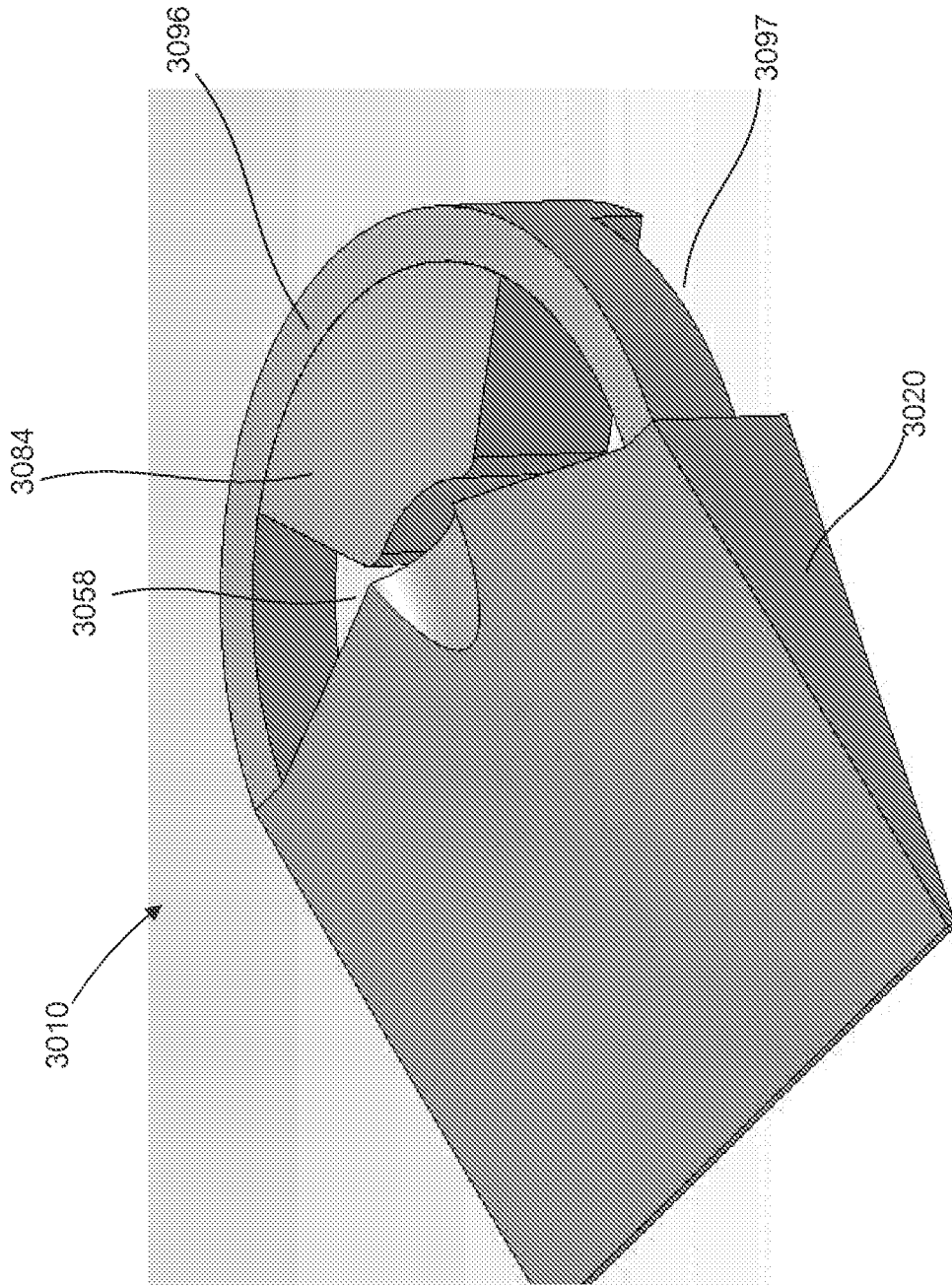
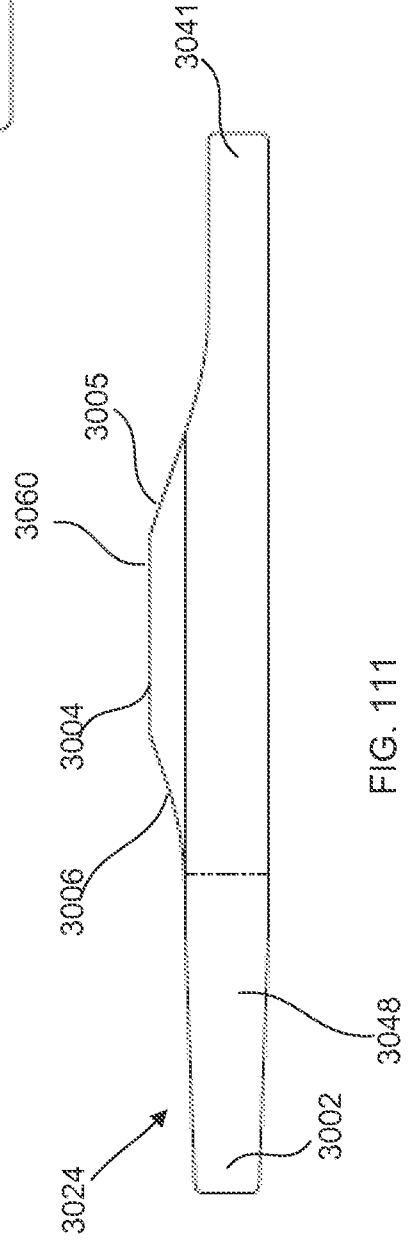
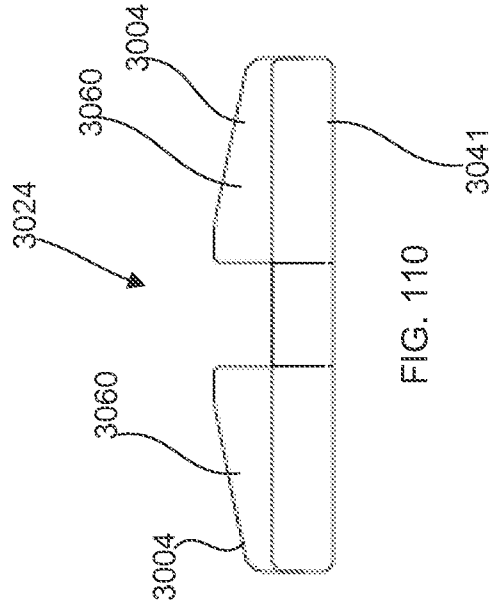
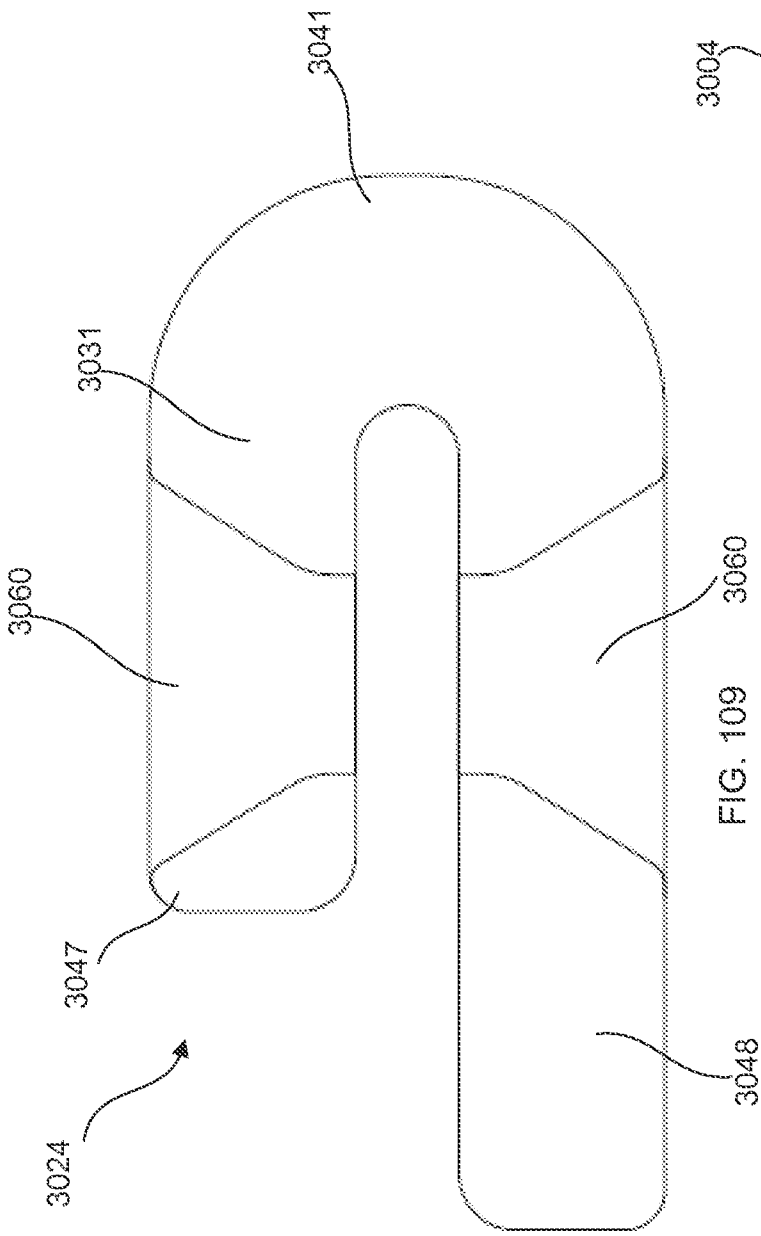

FIG. 108



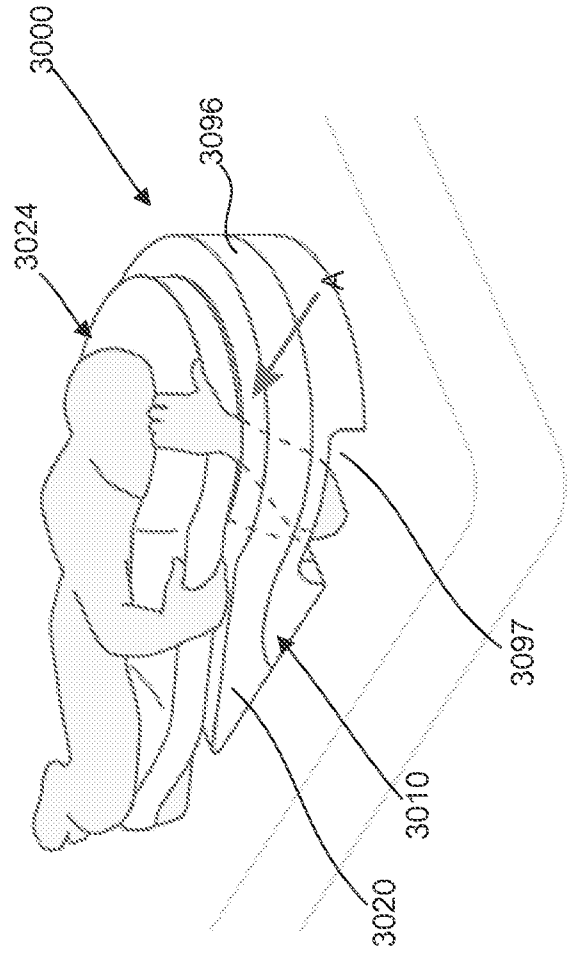
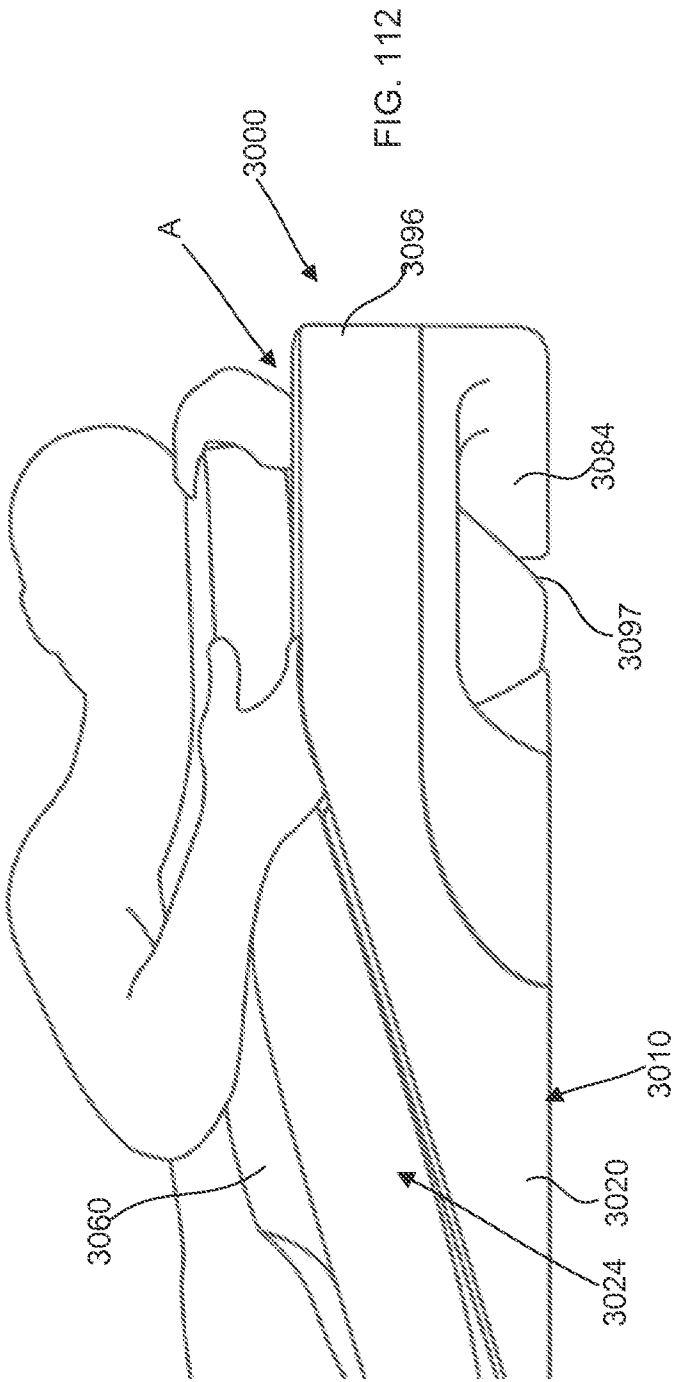

FIG. 113

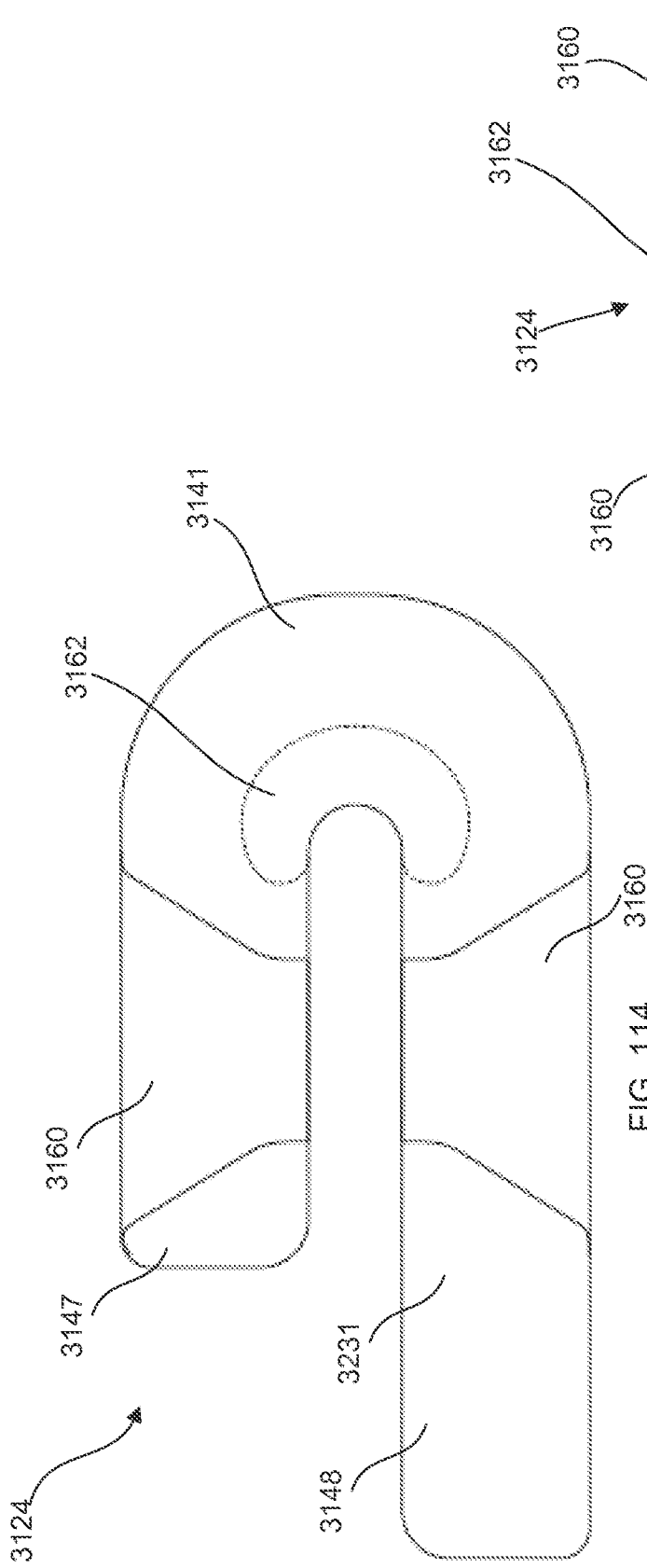

FIG. 114 3160

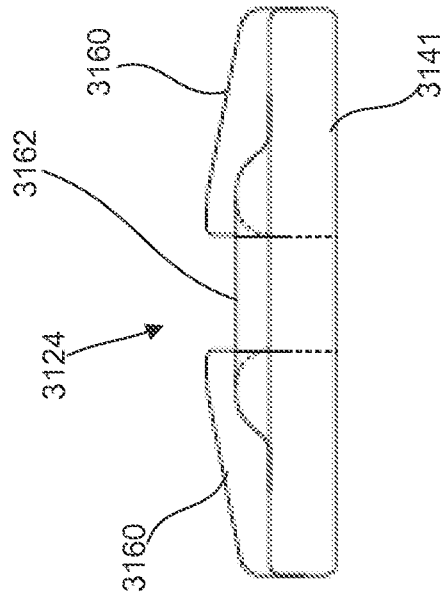

FIG. 115

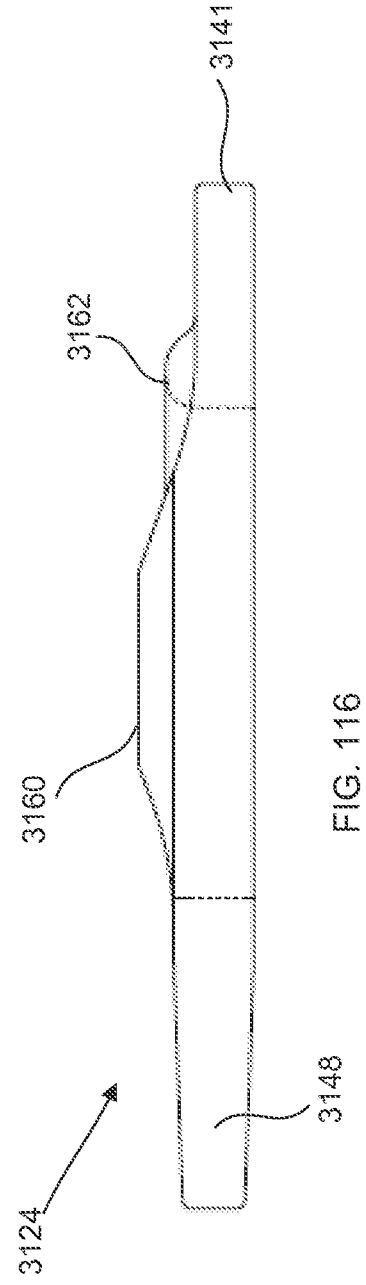

FIG. 116

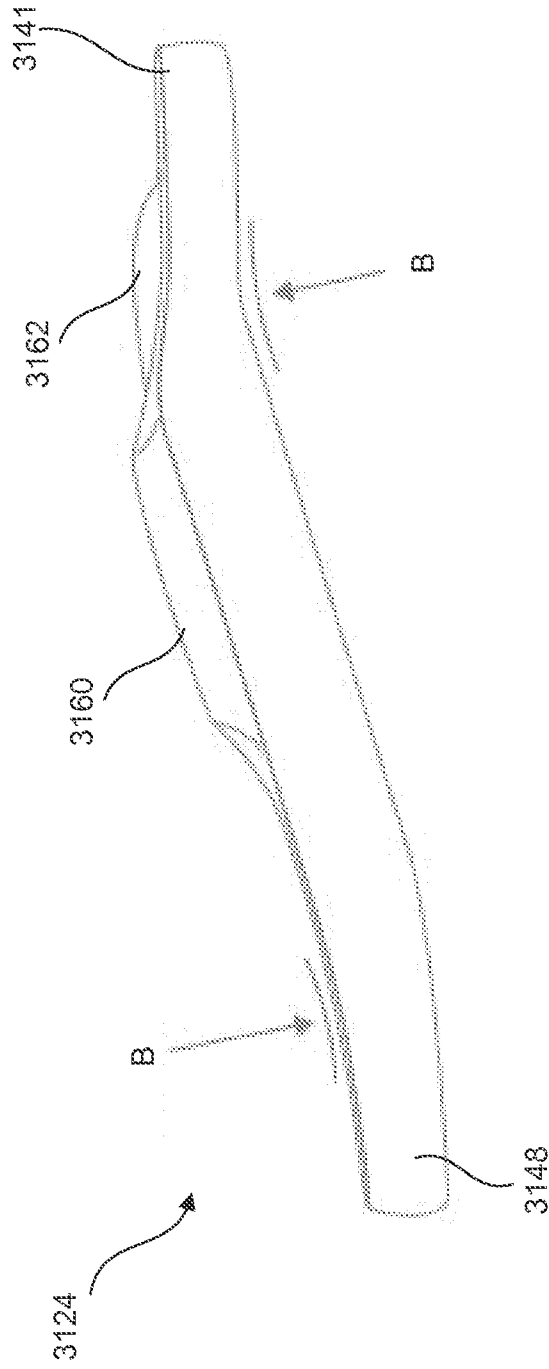
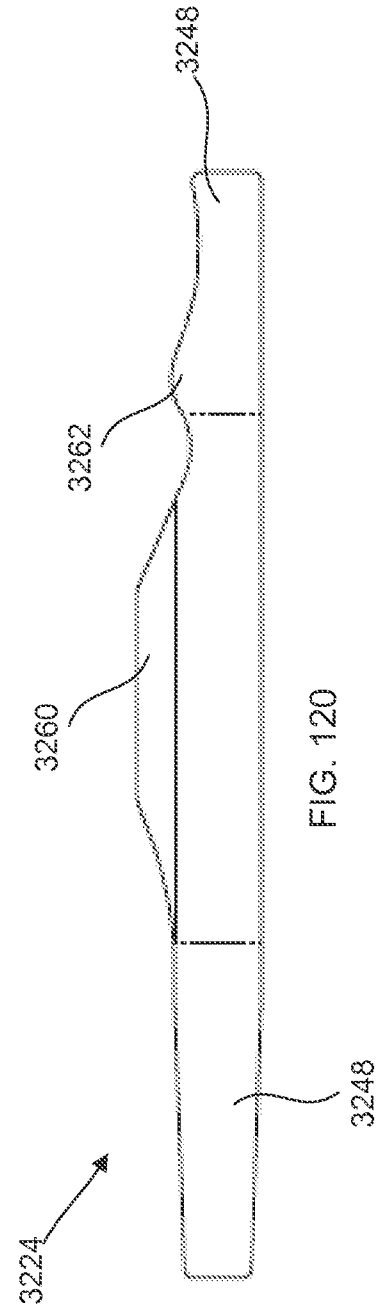
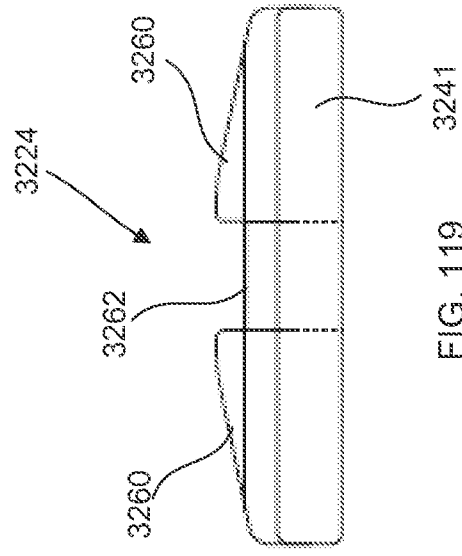
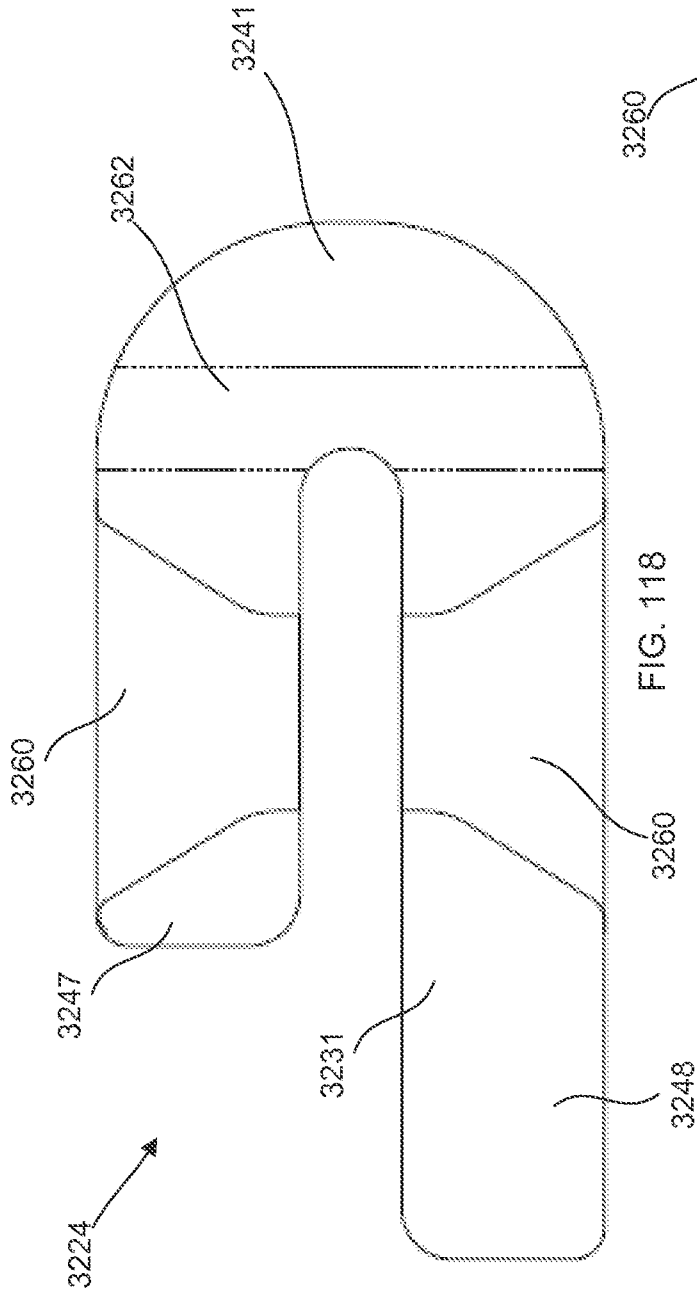

FIG. 117



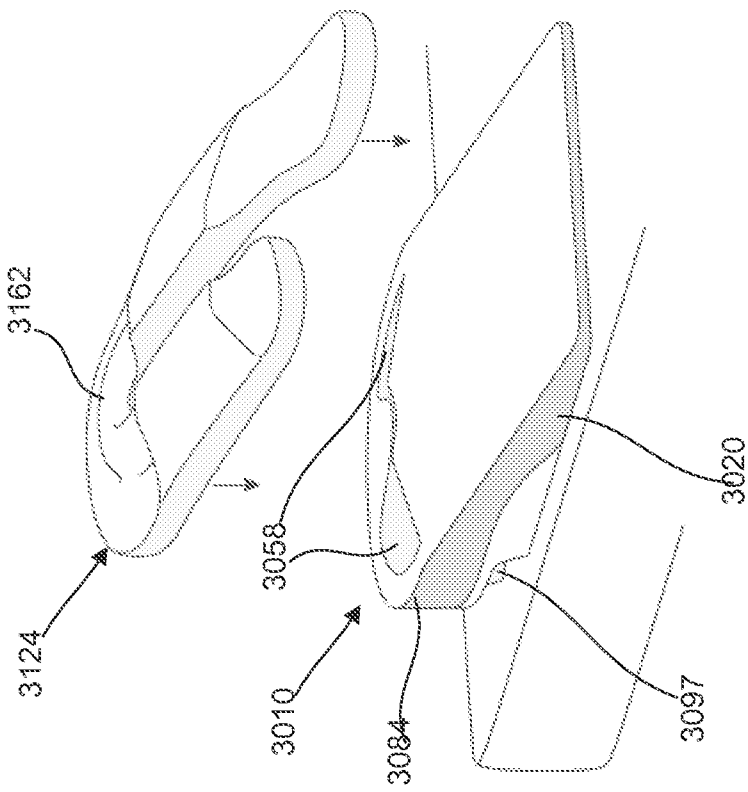

FIG. 121

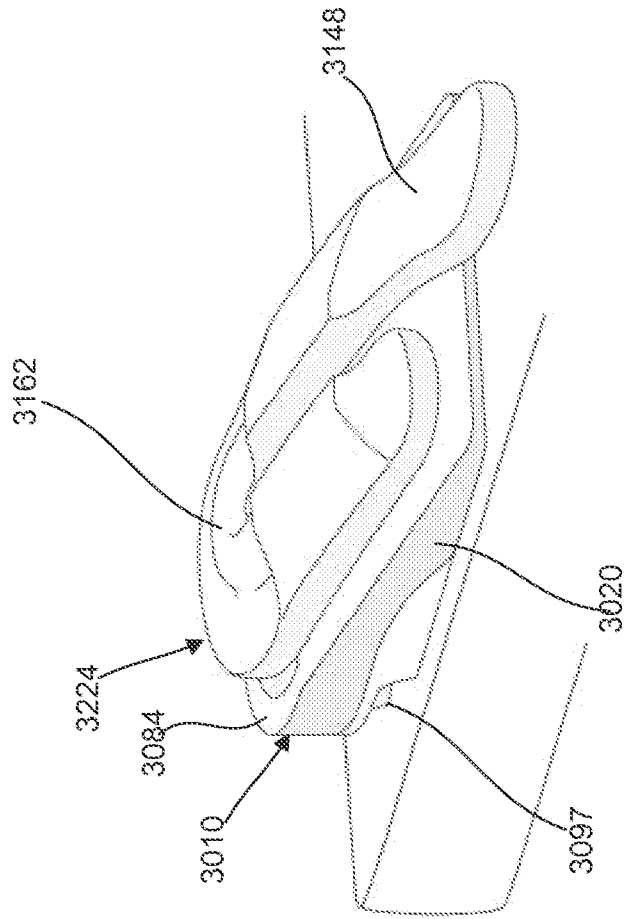

FIG. 122

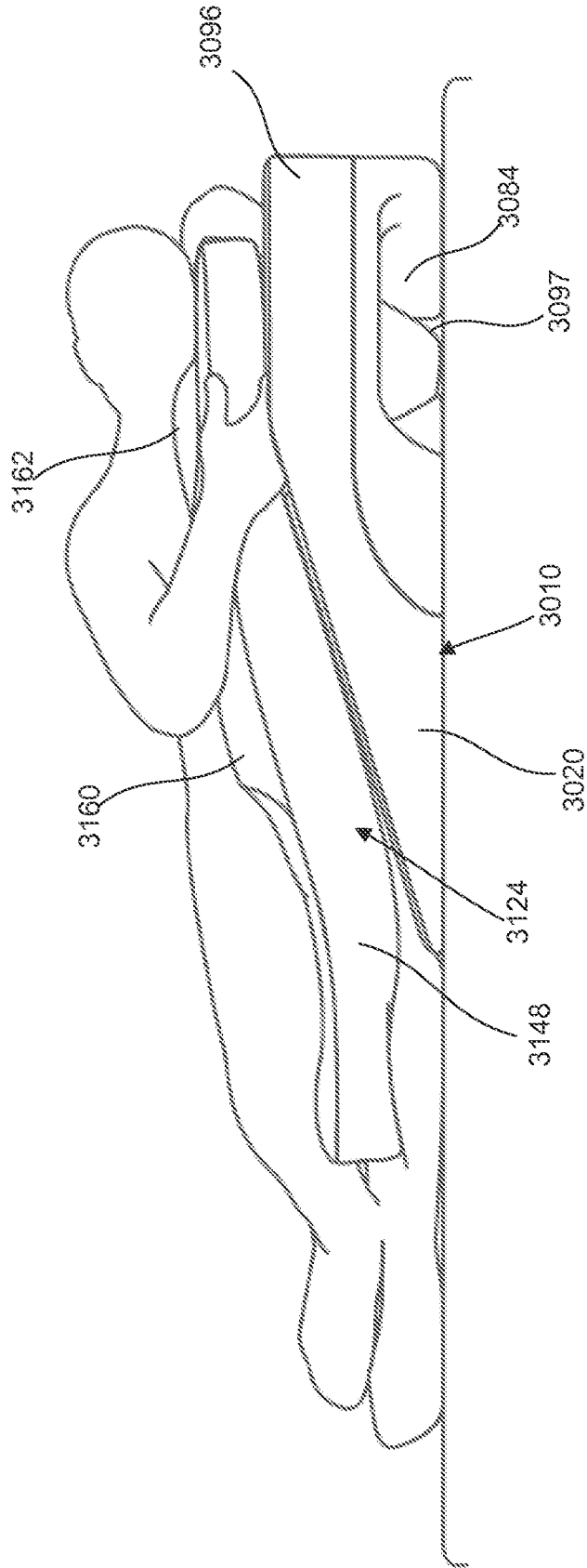

FIG. 123

1A: 6 HOUR ESOPHAGEAL ACID EXPOSURE

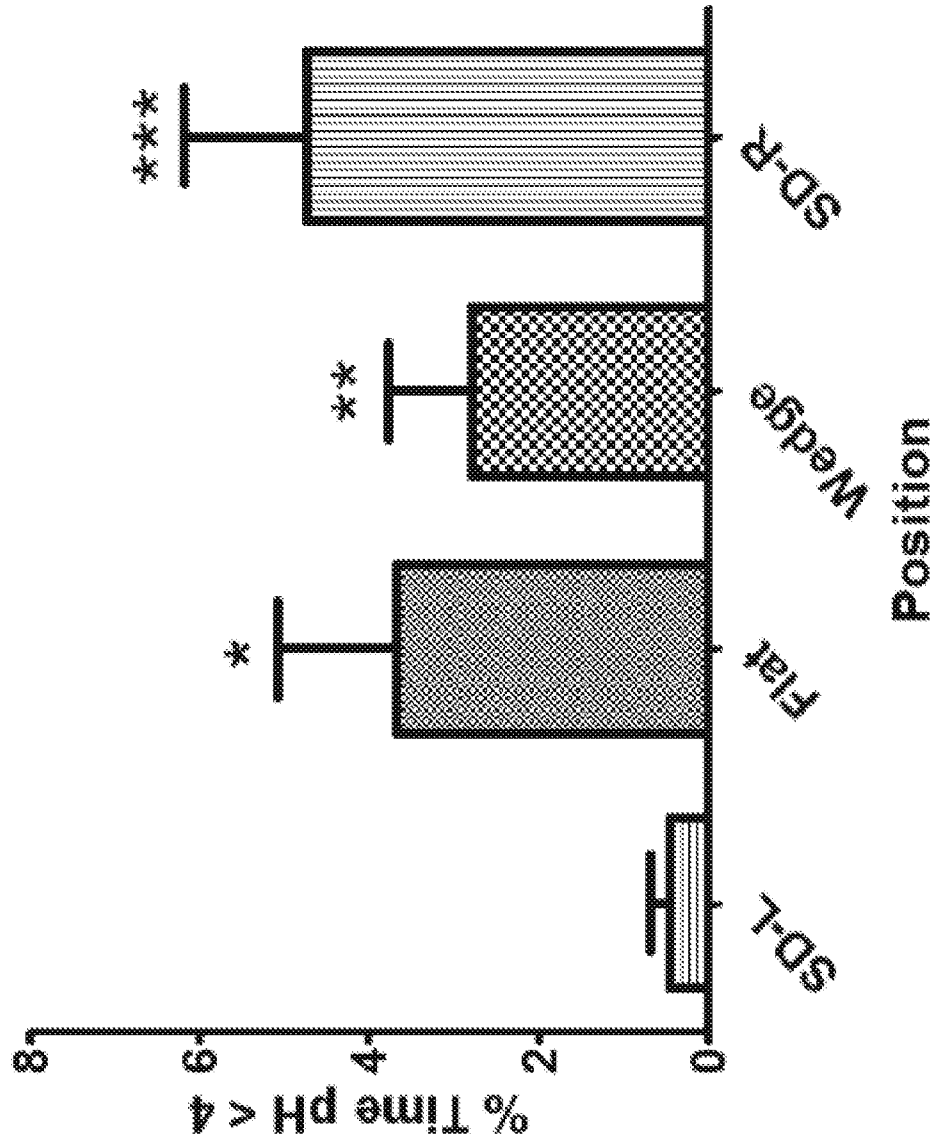

FIG. 124

1B: 6 HOUR NUMBER OF REFLUX EPISODES

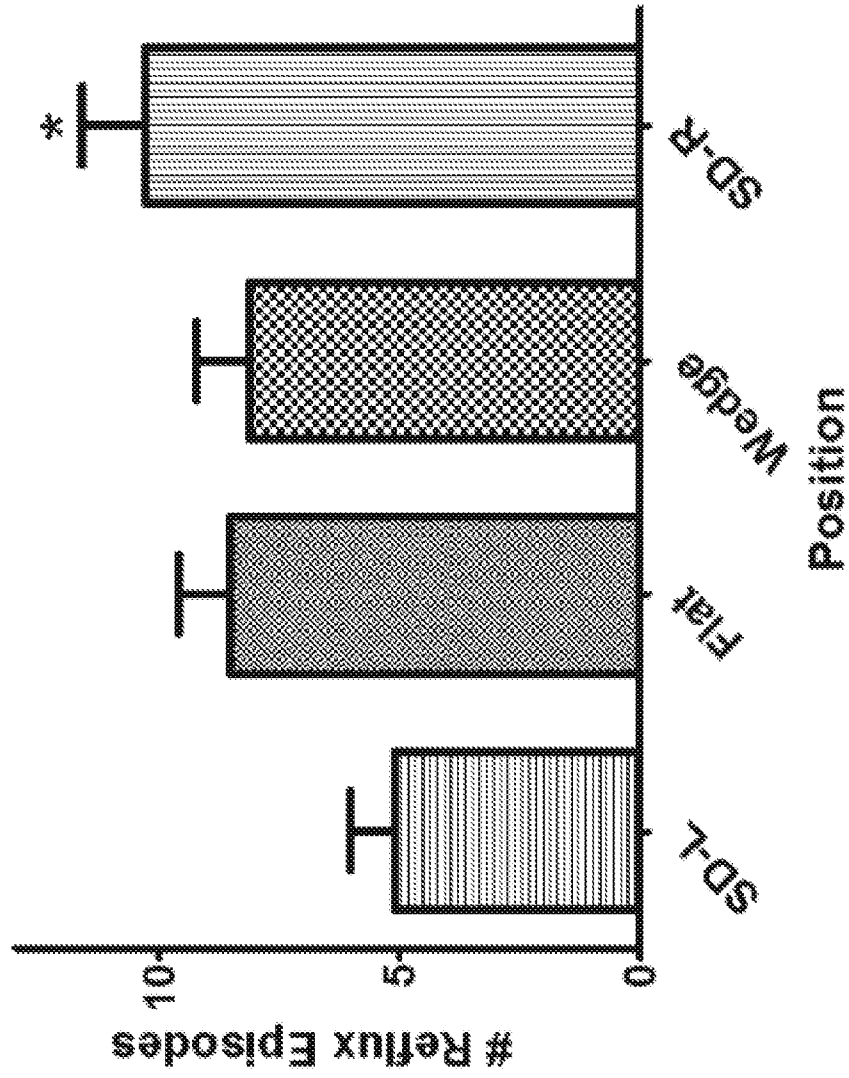

FIG. 125

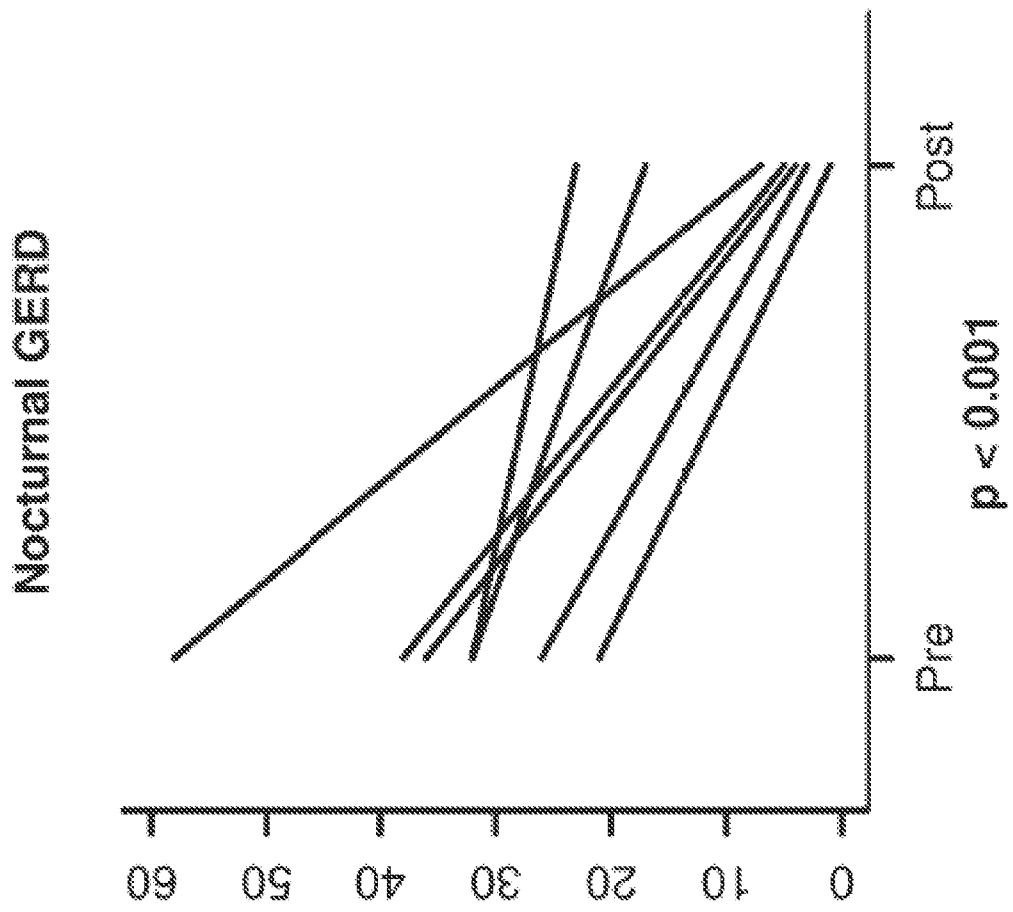

FIG. 126

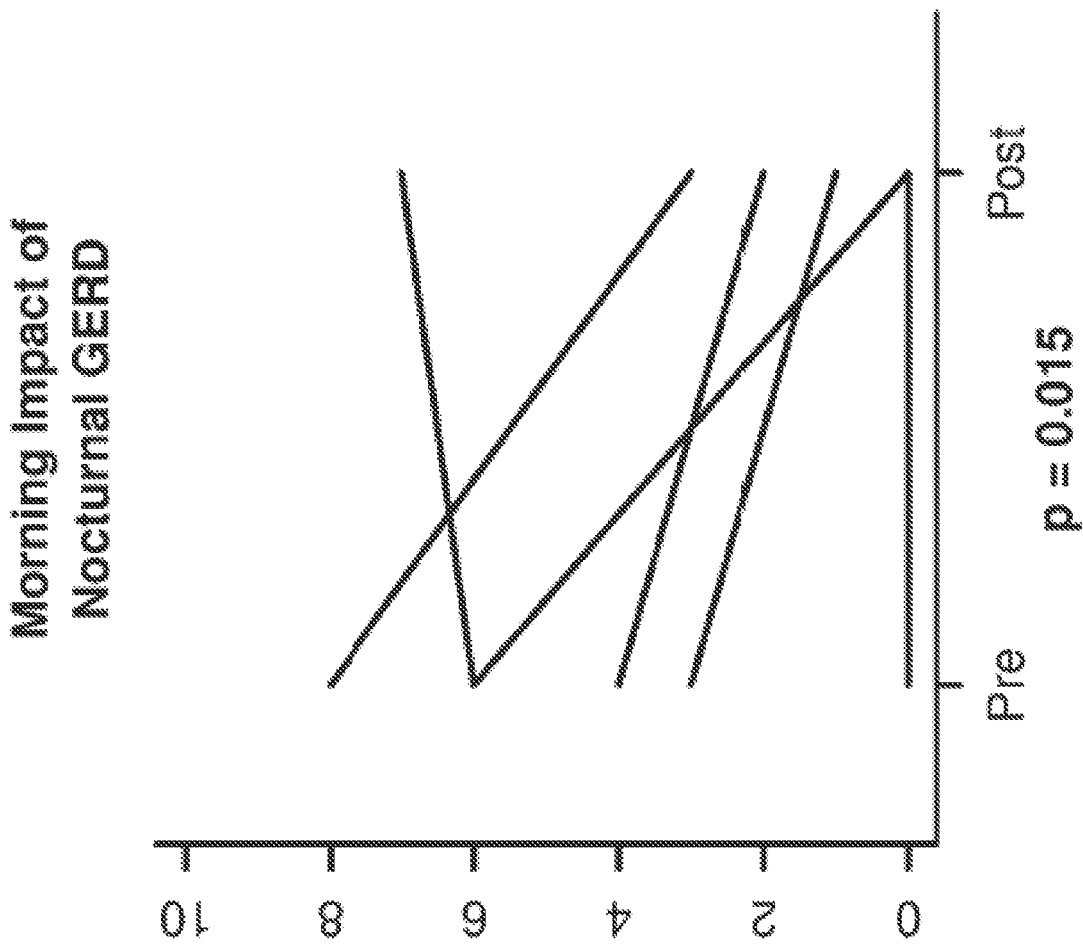

FIG. 127

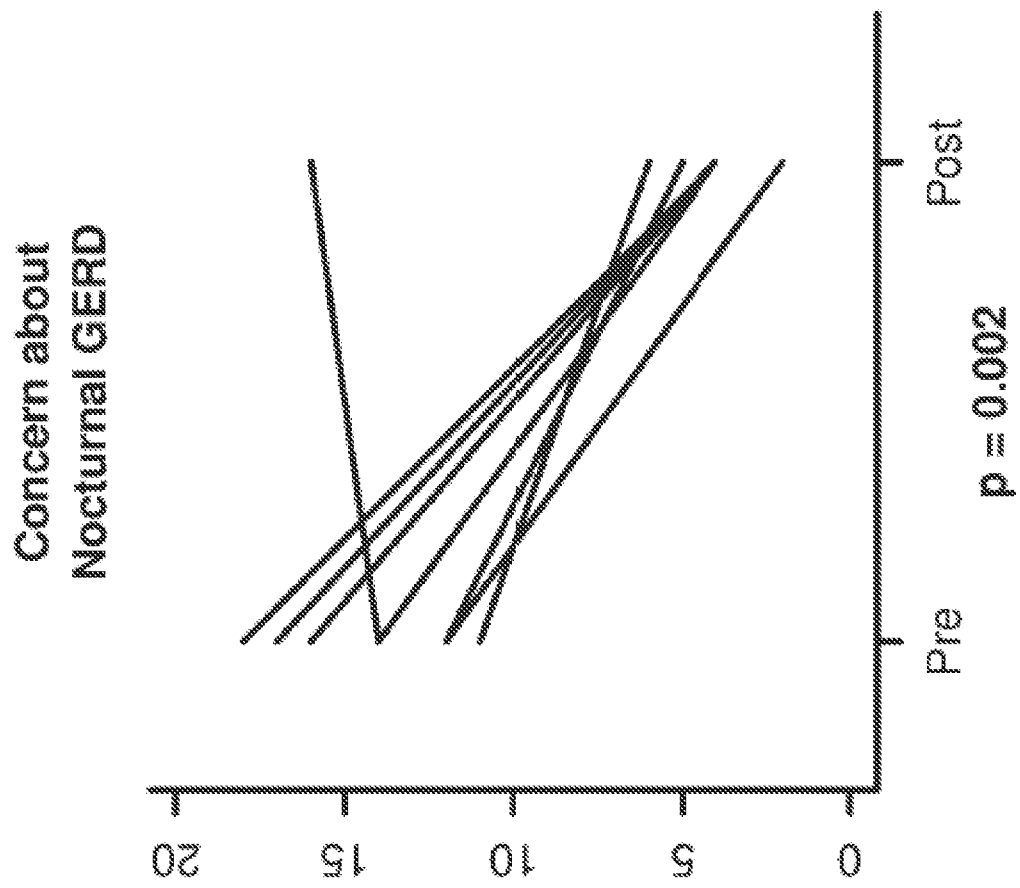

FIG. 128

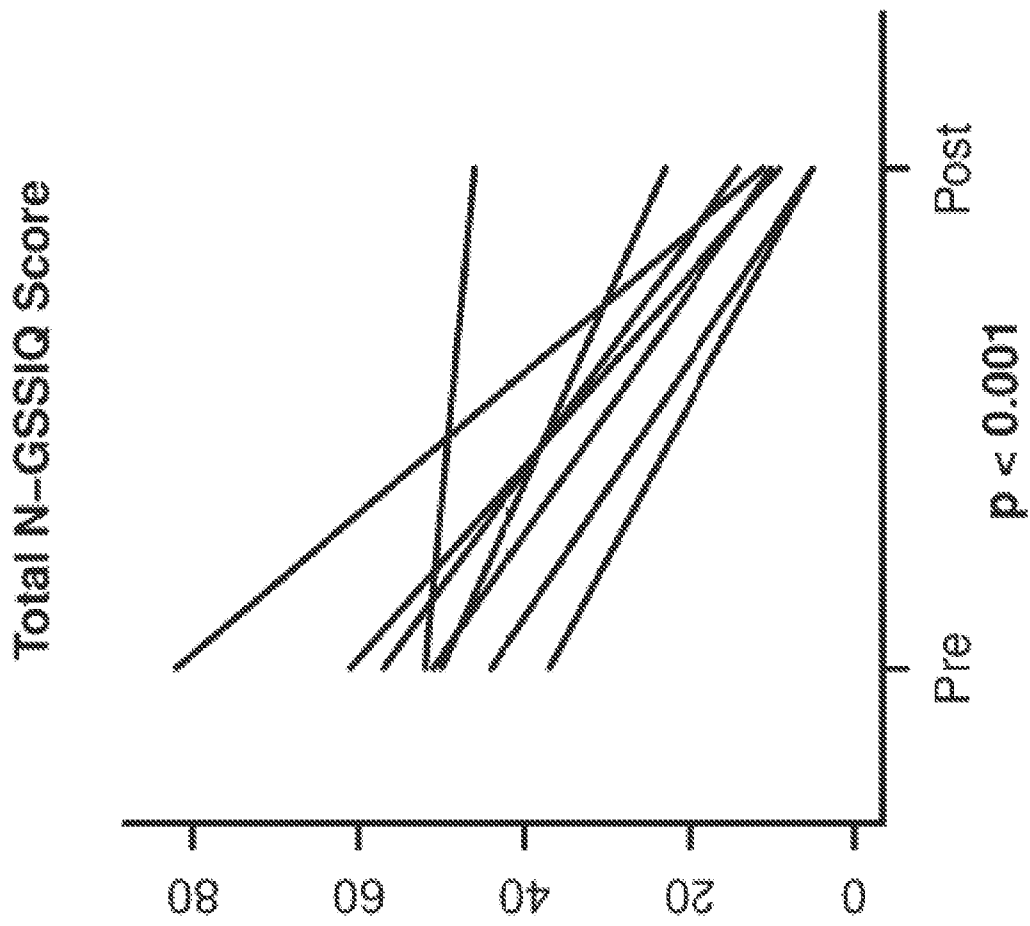

FIG. 129

