



US008851684B2

(12) **United States Patent**  
**Ishikura**

(10) **Patent No.:** **US 8,851,684 B2**

(45) **Date of Patent:** **Oct. 7, 2014**

(54) **OPTICAL UNIT INCLUDING AN INTEGRATOR OPTICAL SYSTEM, AND PROJECTION DISPLAY DEVICE INCLUDING THE OPTICAL UNIT**

(58) **Field of Classification Search**  
CPC ..... G03B 21/2013; G03B 21/208; G03B 21/202; G03B 21/2026; H04N 9/3114; H04N 9/3164  
USPC ..... 353/84, 94; 348/743  
See application file for complete search history.

(75) Inventor: **Naofumi Ishikura**, Tokyo (JP)

(73) Assignee: **NEC Display Solutions, Ltd.**, Tokyo (JP)

(\* ) Notice: Subject to any disclaimer, the term of this patent is extended or adjusted under 35 U.S.C. 154(b) by 418 days.

(56) **References Cited**

U.S. PATENT DOCUMENTS

6,252,636 B1 \* 6/2001 Bartlett ..... 348/743  
6,505,939 B1 \* 1/2003 Bierhuizen et al. .... 353/94  
(Continued)

(21) Appl. No.: **13/375,762**

(22) PCT Filed: **Jun. 18, 2009**

(86) PCT No.: **PCT/JP2009/061089**

§ 371 (c)(1),  
(2), (4) Date: **Dec. 1, 2011**

(87) PCT Pub. No.: **WO2010/146683**

PCT Pub. Date: **Dec. 23, 2010**

(65) **Prior Publication Data**

US 2012/0075592 A1 Mar. 29, 2012

(51) **Int. Cl.**  
**G03B 21/14** (2006.01)  
**G03B 21/20** (2006.01)  
**H04N 9/31** (2006.01)

(52) **U.S. Cl.**  
CPC ..... **G03B 21/14** (2013.01); **G03B 21/202** (2013.01); **H04N 9/3164** (2013.01); **G03B 21/2026** (2013.01); **G03B 21/208** (2013.01); **G03B 21/20** (2013.01); **H04N 9/3114** (2013.01)  
USPC ..... **353/84**; 353/94

FOREIGN PATENT DOCUMENTS

JP 2001-13604 A 1/2001  
JP 2005-115094 A 4/2005

(Continued)

OTHER PUBLICATIONS

International Search Report (ISR) (PCT Form PCT/ISA/210) dated Jul. 14, 2009, in PCT/JP2009/061089.

*Primary Examiner* — Francis M Legasse, Jr.

*Assistant Examiner* — Bao-Luan Le

(74) *Attorney, Agent, or Firm* — McGinn IP Law Group, PLLC

(57) **ABSTRACT**

Provided is an optical unit that includes: light source (1a); light source (1b) located to face light source (1a); color wheel (2) located between light sources (1a and 1b); prism unit (3a) that totally reflects light emitted from light source (1a) and that is transmitted through color wheel (2), and transmits light emitted from light source (1b) to enter color wheel (2); and prism unit (3b) that totally reflects the light emitted from light source (1b) and that is transmitted through color wheel (2), and transmits the light emitted from light source (1a) to enter color wheel (2).

**6 Claims, 11 Drawing Sheets**

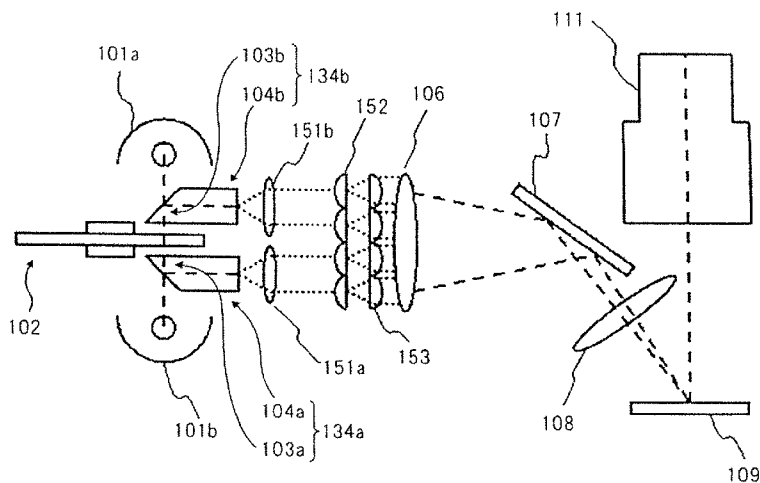

(56)

References Cited

U.S. PATENT DOCUMENTS

6,666,558 B1 \* 12/2003 Yamagishi et al. .... 353/94  
 6,758,579 B2 \* 7/2004 Ishikawa et al. .... 362/238  
 7,033,056 B2 \* 4/2006 Andersen et al. .... 362/554  
 7,530,697 B2 \* 5/2009 Sawai et al. .... 353/94  
 7,628,495 B2 \* 12/2009 Tangen ..... 353/94  
 7,832,876 B2 \* 11/2010 Yagyu ..... 353/94  
 7,871,168 B2 \* 1/2011 Liu et al. .... 353/84  
 7,926,951 B2 \* 4/2011 Bietry et al. .... 353/31  
 8,066,382 B2 \* 11/2011 Silverstein et al. .... 353/20  
 8,235,536 B2 \* 8/2012 Andersen et al. .... 353/94  
 RE43,959 E \* 2/2013 Andersen et al. .... 362/554  
 8,408,709 B2 \* 4/2013 Sawai et al. .... 353/20  
 8,573,779 B2 \* 11/2013 Yamagishi et al. .... 353/33  
 8,622,551 B2 \* 1/2014 Andersen et al. .... 353/94  
 2004/0165155 A1 \* 8/2004 Lee et al. .... 353/81  
 2005/0013142 A1 \* 1/2005 Andersen et al. .... 362/583  
 2005/0146891 A1 \* 7/2005 Hatakeyama ..... 362/551  
 2006/0044523 A1 \* 3/2006 Tejjido et al. .... 353/53

2006/0164726 A1 \* 7/2006 Morejon et al. .... 359/495  
 2006/0244929 A1 \* 11/2006 Sawai et al. .... 353/84  
 2006/0285084 A1 \* 12/2006 Lin ..... 353/84  
 2007/0121084 A1 \* 5/2007 Chang ..... 353/94  
 2007/0268464 A1 11/2007 Lin  
 2009/0027631 A1 \* 1/2009 Liu et al. .... 353/84  
 2009/0153752 A1 \* 6/2009 Silverstein ..... 348/750  
 2009/0213330 A1 \* 8/2009 Silverstein et al. .... 353/8  
 2009/0284713 A1 \* 11/2009 Silverstein et al. .... 353/8  
 2010/0328611 A1 \* 12/2010 Silverstein et al. .... 353/7  
 2011/0007279 A1 \* 1/2011 Silverstein et al. .... 353/8  
 2011/0141438 A1 \* 6/2011 Sawai et al. .... 353/20

FOREIGN PATENT DOCUMENTS

JP 2006-30330 A 2/2006  
 JP 2007-140344 A 6/2007  
 JP 2007-293033 A 11/2007  
 JP 2007-310331 A 11/2007

\* cited by examiner

Fig. 1 (Related Art)

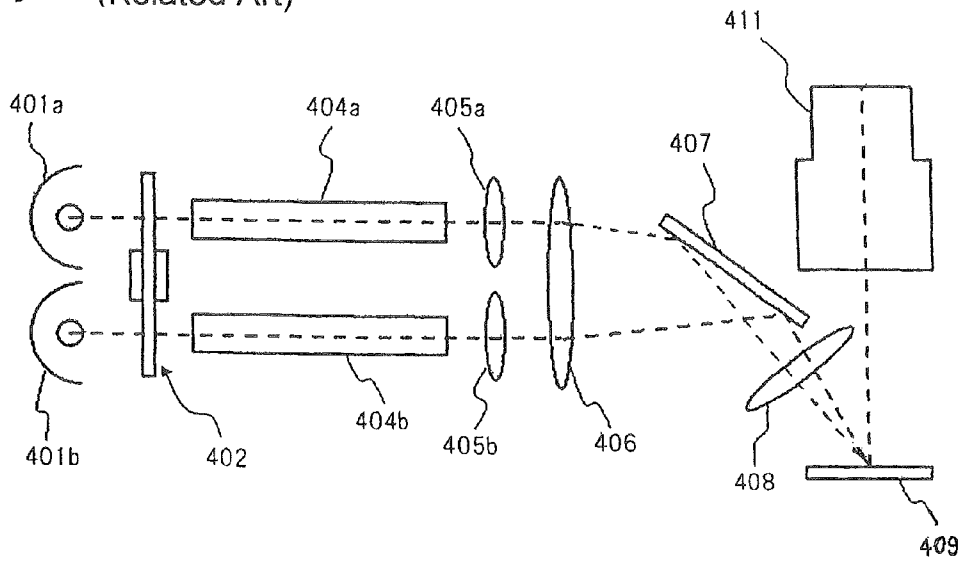

Fig. 2A (Related Art)

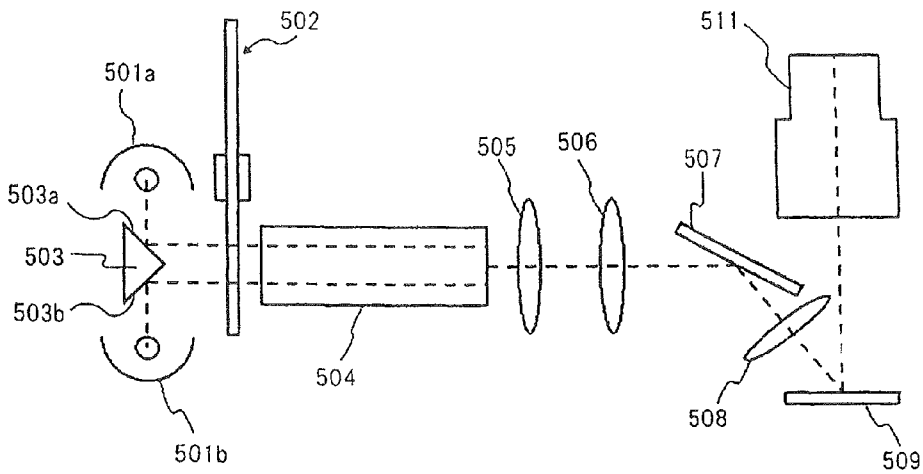

Fig. 2B (Related Art)

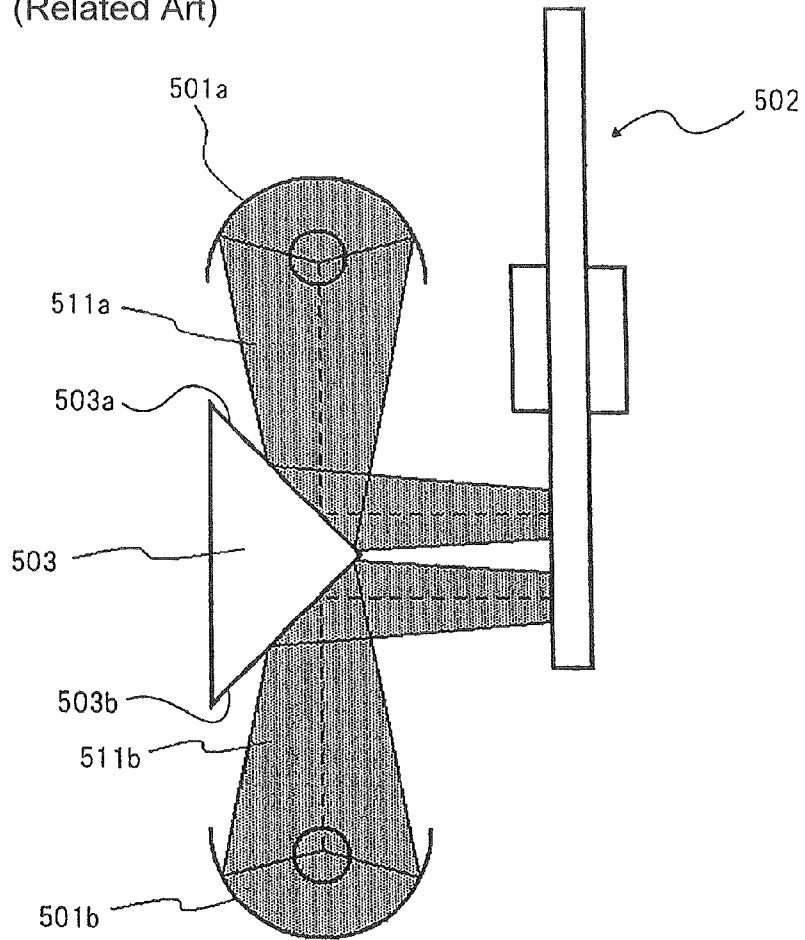

Fig. 2c (Related Art)

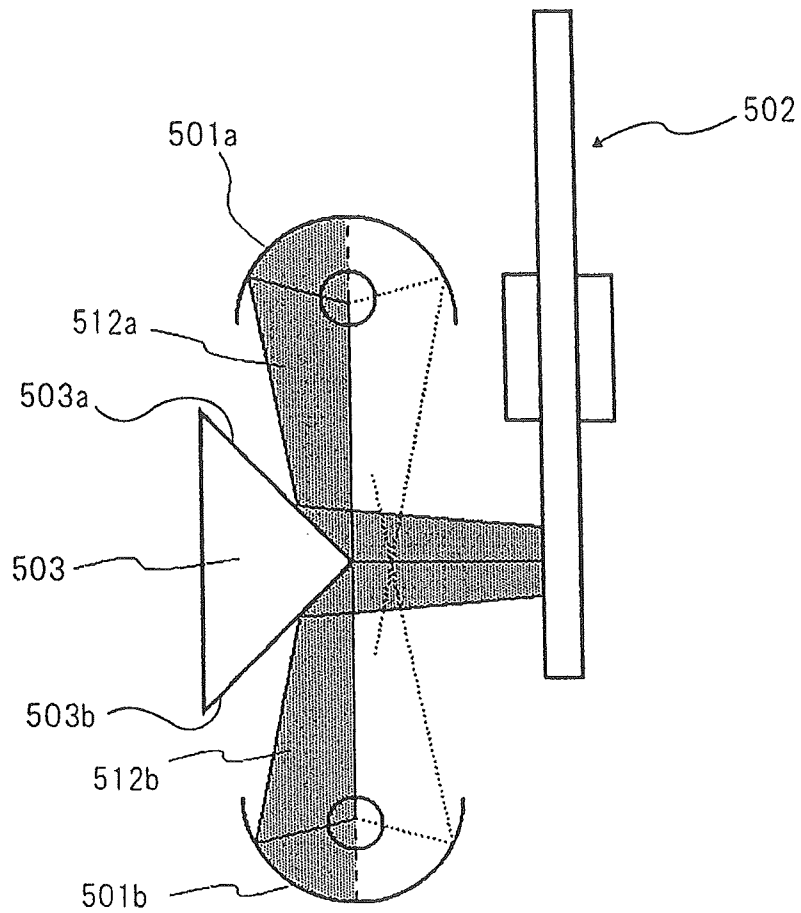

Fig. 2D (Related Art)

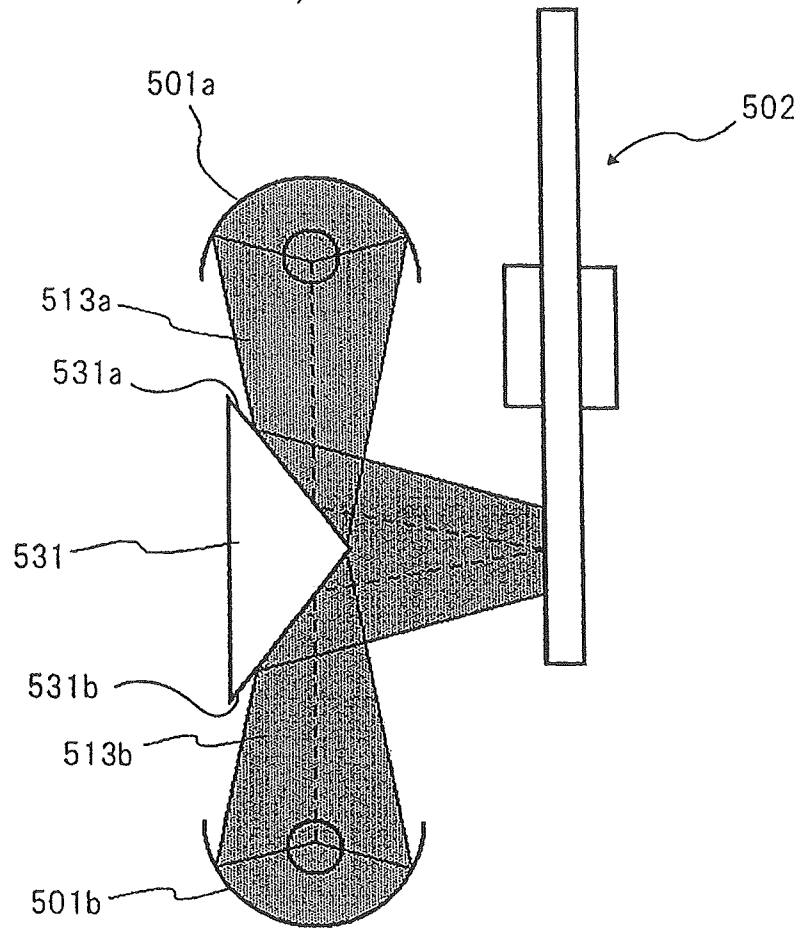

Fig. 3A

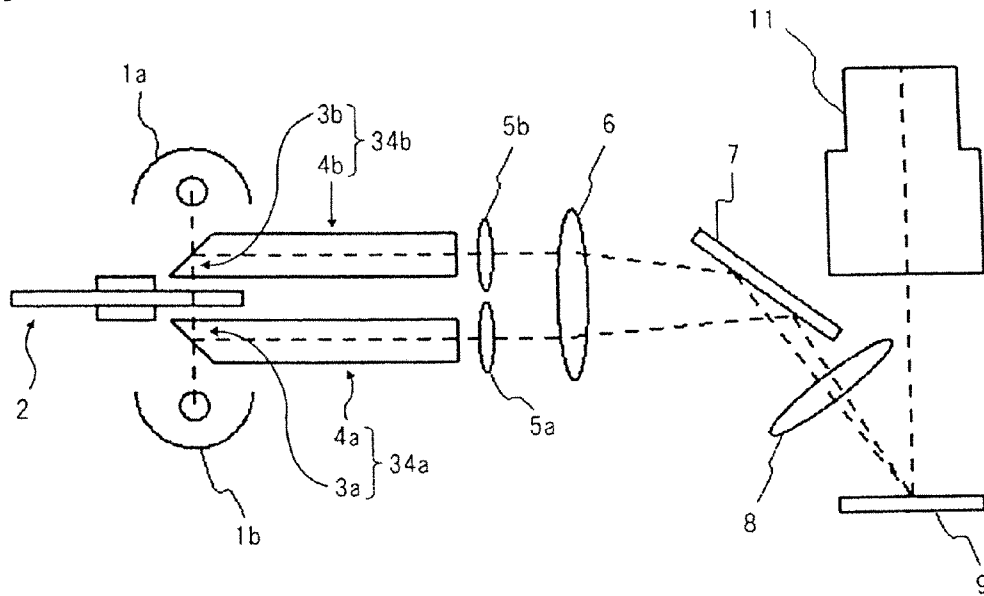

Fig. 3B

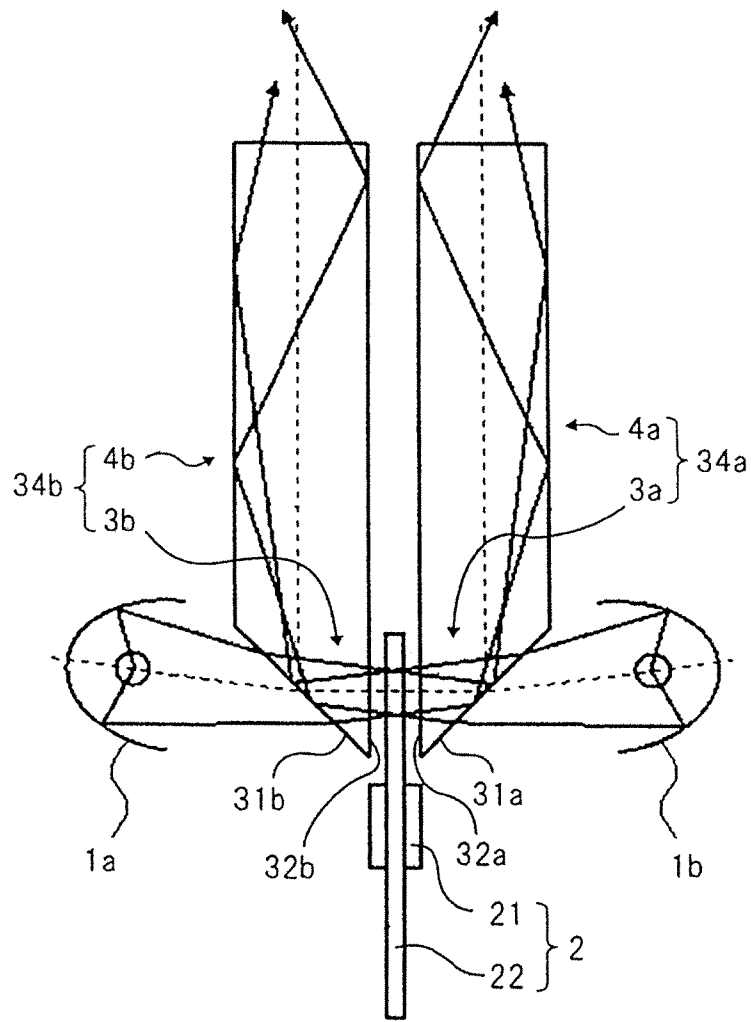

Fig. 4

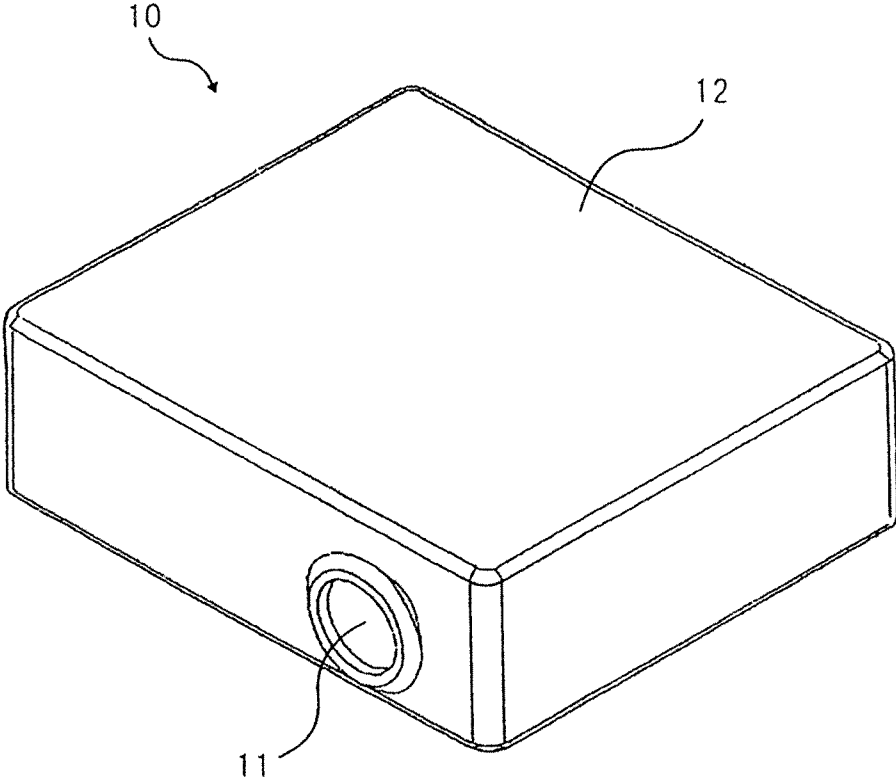

Fig. 5

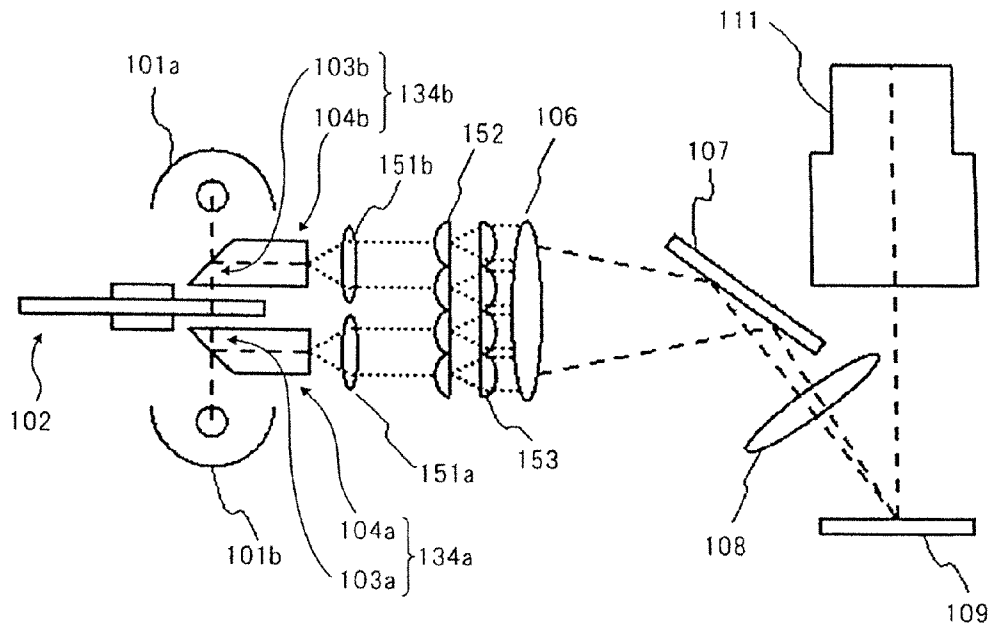

Fig. 6

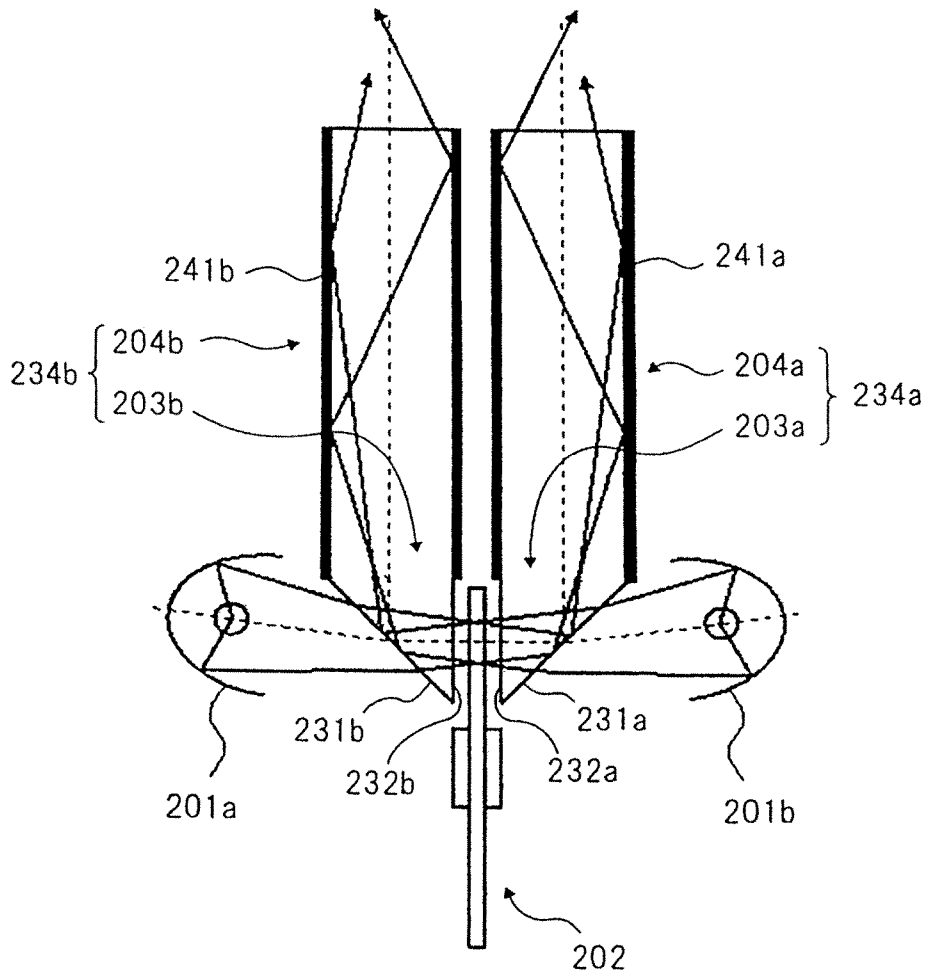

Fig. 7A

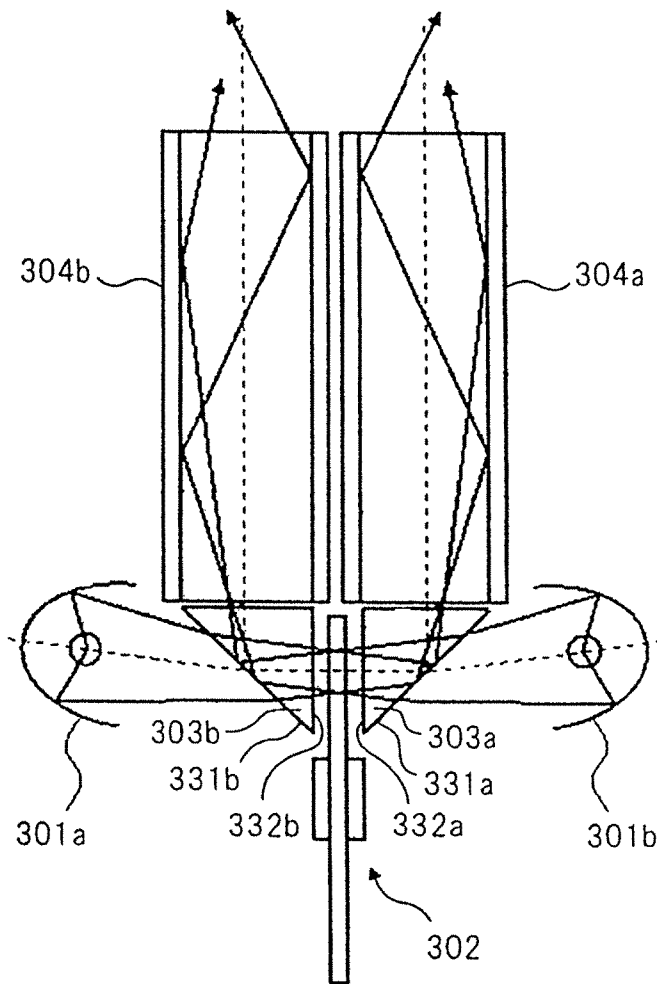
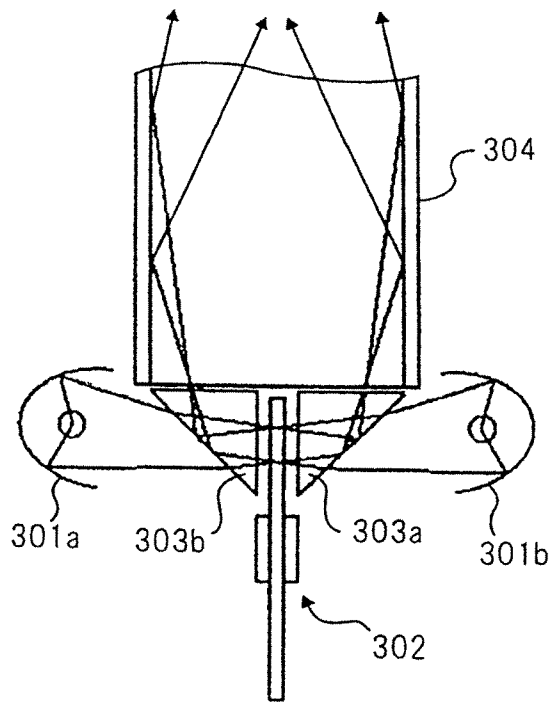

Fig. 7B



**OPTICAL UNIT INCLUDING AN  
INTEGRATOR OPTICAL SYSTEM, AND  
PROJECTION DISPLAY DEVICE INCLUDING  
THE OPTICAL UNIT**

TECHNICAL FIELD

The present invention relates to an optical unit that includes two light sources, and a projection display device.

BACKGROUND ART

There is a projection display device that includes two light sources to acquire light of high luminance. This projection display device enables acquisition of light of high luminance by synthesizing light emitted from the light sources.

FIG. 1 schematically shows an internal mechanism of the projection display device that includes the two light sources. The projection display device includes two light sources **401a** and **401b** located side by side. Two light sources **401a** and **401b** are set in the same direction.

In the projection display device, first, lights from light sources **401** and **401b** enter color wheel **402**. Color wheel **402** is a disk-like member that includes a translucent color filter. The color filter is divided into a plurality of color separation areas in a circumferential direction. Each color separation area selectively allows transmission of only light of a wavelength that becomes red, green or blue. Color wheel **402** can rotate around a central axis. By rotating color filter **402**, the color separation areas through which the lights emitted from light sources **401a** and **401b** are transmitted are continuously changed.

The lights transmitted through color wheel **402** enter one of the ends of rod lenses **404a** and **404b**. Rod lenses **404a** and **404b** are rod-shaped glass members rectangular in section. The lights that have entered one of the ends of rod lenses **404a** and **404b** are transmitted through rod lenses **404a** and **404b** to exit from the other ends. The lights are totally reflected repeatedly on side faces of rod lenses **404a** and **404b** during transmission from one of the ends of rod lenses **404a** and **404b** to the other ends. Thus, luminance distribution is made uniform.

The lights that have exited from rod lenses **404a** and **404b** are transmitted through condenser lenses **405a** and **405b**, and then enter condenser lens **406**. The lights transmitted through condenser lens **406** are reflected by planar lens **407**, and then enter condenser lens **408**.

The lights transmitted through condenser lens **408** enter digital micromirror device (DMD) **409**. DMD **409** is an image forming element having many mirror elements attached on a semiconductor memory cell to be switched on/off individually based on image signals. The lights that have entered DMD **409** and that have been reflected by the mirror elements of DMD **409** to be modulated are magnified and projected on a screen (not shown) from projection lens **411**.

In the projection display device, the lights that have exited from rod lenses **404a** and **404b** gradually approach each other while they are sequentially transmitted through condenser lenses **406** and **408**. The lights overlap each other to become almost one light flux, and enter DMD **409**. Thus, in the projection display device, the lights emitted from two light sources **401a** and **401b** are synthesized through condenser lenses **406** and **408**. This enables displaying of one image on the screen.

However, in the projection display device, the lights emitted from light sources **401a** and **401b** enter positions opposite

each other sandwiching the central axis in the color filter of color wheel **402**. Color wheel **402** is always required to set the light emitted from light source **401a** and the light emitted from light source **401b** similar in color. Thus, the color filter of color wheel **402** must include a pair of opposing color separation areas sandwiching the central axis for each color. In other words, the color filter of color wheel **402** must be divided into six color separation areas in the circumferential direction.

In the projection display device, when the lights emitted from light sources **401a** and **401b** are transmitted through the color separation area of the same color, light of red, green or blue can be acquired. However, when the lights emitted from light sources **401a** and **401b** are transmitted over a boundary between the two color separation areas, two colors are mixed. Light of a color made by mixing the two colors is not used for displaying an image. Thus, during incidence of the lights that are emitted from light sources **401a** and **401b** through two color separation areas, the mirror elements of DMD **409** are all turned off.

As described above, in the projection display device, while the number of colors of light necessary for displaying the image is three, namely, red, green, and blue, the color filter must be divided into twice as many as the number of colors, namely, six color separation areas. The number of times of turning off all the mirror elements of DMD **409** per rotation of color wheel **402** is three when there are three color separation areas. However, the number is six in the projection display device. As a result, in the projection display device, the lights emitted from light sources **401a** and **401b** cannot be efficiently used for displaying the image.

FIG. 2A is a configuration view schematically showing an internal mechanism of a projection display device including two light sources and configured to transmit lights emitted from the light sources through the same color separation area of a color filter. The projection display device shown in FIG. 2A is similar in configuration to the projection display device shown in FIG. 1 except for a configuration described below.

The projection display device includes triangular prism **503** that includes mirror-coated surfaces **503a** and **503b**. In the projection display device, lights emitted from light sources **501a** and **501b** are reflected by surfaces **503a** and **503b** of triangular prism **503**, transmitted through positions of a color filter of color wheel **502** approaching each other, and then enter one end of rod lens **504**. In the projection display device, therefore, the lights emitted from light sources **501a** and **501b** can be transmitted through the same color separation area of the color filter. Thus, the color filter is only required to be divided into three color separation areas equal to the number of colors of light necessary for displaying an image.

CITATION LIST

Patent Literature

Patent Literature 1:JP2001-13604A

Problems to be Solved

However, in the projection display device shown in FIG. 2A, as shown in FIG. 2B, the lights emitted from light sources **501a** and **501b** enter the color filter of color wheel **502** as different light fluxes **511a** and **511b**. This requires each color separation area of the color filter to be large enough to transmit the lights emitted from light sources **501a** and **501b**. Thus,

in the projection display device, the color filter must be formed larger than that in the case of one light source.

As shown in FIG. 2C, the relative positions of light sources 501a and 501b and triangular prism 503 can be changed so that light fluxes 512a and 512b from light sources 501a and 501b enter color wheel 502 as one light flux. This eliminates the necessity of forming a large color filter.

In this case, however, one half of the lights emitted from light sources 501a and 501b on color wheel 502 side does not enter surfaces 503a and 503b of triangular prism 503. Hence, it is not projected from projection lens 511 shown in FIG. 2A. In other words, only one half of the lights emitted from light sources 501a and 502b is projected from projection lens 511. In this case, therefore, only light whose luminance is equal to that in the case of one light source can be acquired.

As shown in FIG. 2D, the shape of the prism can be changed so that two light fluxes 513a and 513b from light sources 501a and 501b can intersect each other at color wheel 502. The lights emitted from light sources 501a and 501b are accordingly transmitted through the same position of the color filter of color wheel 502. This eliminates the necessity of forming a large color filter.

In this case, however, light expansion becomes large when the lights emitted from light sources 501a and 501b enter rod lens 504 after transmission through color wheel 502. Lights exiting from rod lens 504 are similarly diffused greatly, and hence the area of light flux transmitted after rod lens 504 becomes thick. As a result, to transmit sufficient light, members such as condenser lenses 505 and 506 must be formed large.

It is therefore an object of the present invention to provide an optical unit that includes two light sources, and a projection display device.

### SUMMARY OF INVENTION

To achieve the object of the present invention, an optical unit includes: a first light source; a second light source located to face the first light source; a color wheel located between the first light source and the second light source; a first optical path conversion unit that totally reflects light emitted from the first light source and transmitted through the color wheel, and transmits light emitted from the second light source to enter color wheel; and a second optical path conversion unit that totally reflects the light emitted from the second light source and transmitted through the color wheel, and transmits the light emitted from the first light source to enter the color wheel.

#### Effect of Invention

According to the present invention, the compact optical unit that includes the two light sources, and a projection display device can be provided.

### BRIEF DESCRIPTION OF DRAWINGS

FIG. 1 is a configuration view schematically showing an internal mechanism of a projection display device according to the present invention.

FIG. 2A is a configuration view schematically showing an internal mechanism of a projection display device according to the present invention.

FIG. 2B is a partially enlarged view schematically showing the internal mechanism of the projection display device shown in FIG. 2A.

FIG. 2C is a partially enlarged view schematically showing the internal mechanism of the projection display device shown in FIG. 2A.

FIG. 2D is a partially enlarged view schematically showing the internal mechanism of the projection display device shown in FIG. 2A.

FIG. 3A is a configuration view schematically showing an internal mechanism of a projection display device according to a first embodiment of the present invention.

FIG. 3B is a partially enlarged view schematically showing the internal mechanism of the projection display device shown in FIG. 3A.

FIG. 4 is a perspective view showing the projection display device that includes the internal mechanism shown in FIG. 3A.

FIG. 5 is a configuration view schematically showing an internal mechanism of a projection display device according to a second embodiment of the present invention.

FIG. 6 is a configuration view schematically showing an internal mechanism of a projection display device according to a third embodiment of the present invention.

FIG. 7A is a configuration view schematically showing an internal mechanism of a projection display device according to a fourth embodiment of the present invention.

FIG. 7B is a configuration view schematically showing a modified example of the internal mechanism of the projection display device shown in FIG. 7A.

### DESCRIPTION OF EMBODIMENTS

Next, the preferred embodiments of the present invention are described with reference to the accompanying drawings.

#### First Embodiment

FIG. 3A is a configuration view schematically showing an internal mechanism of a projection display device according to a first embodiment of the present invention. FIG. 3B is an enlarged view showing light sources, a color wheel, and light guide rods shown in FIG. 3A.

The projection display device according to the embodiment includes two light sources 1a and 1b located to face each other. For light sources 1a and 1b, extra-high-pressure mercury lamps are used. For the lights sources, others such as metal halide lamps, halogen lamps, or xenon lamps can be used. Color wheel 2 is disposed between light sources 1a and 1b. Color wheel 2 includes translucent color filter 22, and motor 21 for rotating color wheel 2 around a central axis.

The projection display device includes two rod-shaped light guide rods 34a and 34b. Light guide rods 34a and 34b are made of glass such as BK7 where a transmittance of light (wavelength 400 nanometers to 700 nanometers) of a visible area is at least 99.4%. Light guide rods 34a and 34b are arranged in parallel.

Prism unit 3a is disposed at one end of light guide rod 34a. Prism unit 3a is located between light source 1b and color wheel 2. A surface of prism unit 3a on light source 1b side is slope 31a obliquely inclined in a longitudinal direction of light guide rod 34a. Light guide rod 34a includes rod lens unit 4a that extends from prism unit 3a to the other end of light guide rod 34a. Rod lens unit 4a is rectangular in section.

Prism unit 3b is disposed at one end of light guide rod 34b. Prism unit 3b is located between light source 1a and color wheel 2. A surface of prism unit 3b on light source 1a side is slope 31b obliquely inclined in a longitudinal direction of light guide rod 34b. Light guide rod 34b includes rod lens unit

5

**4b** that extends from prism unit **3b** to the other end of light guide rod **34b**. Rod lens unit **4b** is rectangular in the cross section.

In the projection display device, the light emitted from light source **1a** first enters slope **31b** of prism unit **3b**, and is then transmitted through prim unit **3b** to exit from surface **32b**. The light that has exited from surface **32b** of prism unit **3b** enters color filter **22** of color wheel **2**.

The light emitted from light source **1a** and transmitted through color filter **22** enters surface **32a** of prism unit **3a**, and is then transmitted through prism unit **3a** to enter slope **31a** from the inside of prism unit **3a**. Prism unit **3a** is formed so that an incident angle of the light emitted from light source **1a**, when it enters slope **31a**, can be larger than a critical angle.

The light that has entered prism unit **3a** is accordingly reflected totally by slope **31a** without exiting from slope **31a**, and enters one end of rod lens unit **4a** of light guide rod **34a**. Thus, prism unit **3a** functions as a first optical path conversion unit that changes the traveling direction of the light emitted from light source **1a**, and guides the light emitted from light source **1a** to one end of rod lens **4a**.

The light that has entered rod lens unit **4a** is transmitted through rod lens unit **4a** to exit from the other end. This light is repeatedly reflected, during its transmission from one end of rod lens **4a** to the other end, totally by the side face of rod lens **4a** so that the light is caused to have an uniform luminance distribution.

The light emitted from light source **1b** first enters slope **31a** of prism unit **3a**, and is then transmitted through prism unit **3a** to exit from surface **32a**. The light that has exited from surface **32a** of prism unit **3a** is transmitted through the same position as that of color filter **22** of color wheel **2** through which the light emitted from light source **1a** is transmitted from a side opposite the light emitted from light source **1a**.

Thus, in the projection display device according to the embodiment, the lights emitted from light sources **1a** and **1b** are transmitted through the same position from both sides of color filter **22**, and hence there is no need to enlarge the color separation area of color filter **22**. Therefore, while the projection display device includes the two light sources, a size of color filter **22** can be equal to the size of one light source in the case in which there is only one light source.

The light emitted from light source **1b** and transmitted through color filter **22** enters surface **32b** of prism unit **3b**, and is then transmitted through prism unit **3b** to enter slope **31b** from the inside of prism unit **3b**. Prism unit **3b** is formed so that an incident angle of the light emitted from light source **1b** when it enters slope **31b** can be larger than a critical angle.

The light that has entered prism unit **3b** is accordingly reflected totally by slope **31b** without exiting from slope **31b**, and enters one end of rod lens unit **4b** of light guide rod **34b**. Thus, prism unit **3b** functions as a second optical path conversion unit that changes the traveling direction of the light emitted from light source **1b**, and guides the light emitted from light source **1b** to one end of rod lens **4b**.

The light that has entered rod lens unit **4b** is transmitted through rod lens unit **4b** to exit from the other end. This light is repeatedly reflected, during its transmission from one end of rod lens **4b** to the other end, totally by the side face of rod lens **4b** so that the lights is caused to have an uniform luminance distribution.

In the projection display device according to the embodiment, prism units **3a** and **3b** and rod lens units **4a** and **4b** are integrally formed, and hence the number of components is smaller than when these components are separately provided. This reduces manufacturing costs.

6

The lights from rod lens units **4a** and **4b** are transmitted through condenser lenses **5a** and **5b**, and then enter condenser lens **6**. The lights transmitted through condenser lens **6** are reflected by planar mirror **7**, and then transmitted through condenser lens **8** to enter DMD **9**. Thus, condenser lenses **5a**, **5b**, **6**, and **8**, and planar mirror **7** constitute a relay optical system for guiding the lights to DMD **9**.

The lights transmitted through condenser lenses **5a** and **5b** gradually approach each other while sequentially being transmitted through condenser lenses **6** and **8**. The lights overlap each other to enter DMD **9** as almost one light flux. In other words, condenser lenses **6** and **8** function as relay optical systems, and as synthesis mechanisms of synthesizing the lights emitted from light sources **1a** and **1b**. This makes the lights entering DMD **9** twice as bright as the light in the case of one light source.

As described above, in the projection display device according to the embodiment, the optical unit is configured to separate the lights emitted from two light sources **1a** and **1b** by color, make the light uniform, and synthesize the lights. The inclusion of the optical unit in the projection display device enables color-separated, uniform and bright lights to enter DMD **9** that is an illumination target.

The lights that have exited from the optical unit to enter DMD **9** are reflected by mirror elements included in DMD **9** to be modulated. The lights modulated by DMD **9** are magnified to be projected on a screen (not shown) from projection lens **11**. DMD **9** can be changed to another image forming element, and projection lens **11** can be changed to another projection optical system.

FIG. **4** is a perspective view showing the projection display device that includes the internal mechanism shown in FIG. **3A**. In projection display device **10**, the internal mechanism shown in FIG. **3A** is covered with case **12**, and projection lens **11** is exposed to a side face of case **12**. In this projection display device, the internal mechanism is operated as described above to project lights from projection lens **11**, thereby displaying an image on the screen. In the projection display device, the optical unit enables bright lights to enter DMD **9**. Thus, a bright and clear image can be displayed on the screen.

#### Second Embodiment

FIG. **5** is a configuration view schematically showing an internal mechanism of a projection display device according to a second embodiment of the present invention. The projection display device according to the embodiment is similar in configuration to the projection display device of the first embodiment except for the configuration described below.

The projection display device according to the embodiment includes collimator lenses **151a** and **151b**, first fly-eye lens **152**, and second fly-eye lens **153**. Collimator lenses **151a** and **151b** convert diffused lights into parallel lights. Fly-eye lenses **152** and **153** are configured by arranging a plurality of single lenses in a matrix, one surface of each being convex and the other surface being planar. Planar sides of fly-eye lenses **152** and **153** face each other.

In the projection display device, lights emitted from light sources **101a** and **101b** are transmitted through color wheel **102**, and are totally reflected by prism units **103a** and **103b** to enter rod lens units **104a** and **104b**. The lights transmitted through rod lenses **104a** and **104b** are transmitted through collimator lenses **151a** and **151b** to be converted from diffused lights into parallel lights. The parallel lights transmitted through collimator lenses **151a** and **151b** enter first fly-eye lens **152** from the convex surface side. The lights transmitted

through first fly-eye lens **152** enter second fly-eye lens **153** from the planar surface side. The lights are overlapped during transmission through fly-eye lenses **152** and **153** so that the lights are caused to have a uniform luminance distribution.

The lights transmitted through fly-eye lenses **152** and **153** and made to have an uniform luminance distribution are transmitted through lens **106**, reflected by planar mirror **107**, and are then transmitted through condenser lens **108**. The lights transmitted through condenser lens **108** are modulated by DMD **109**, and then magnified to be projected on a screen from projection lens **111**.

In the projection display device according to the embodiment, collimator lenses **151a** and **151b**, first fly-eye lens **152**, and second fly-eye lens **153** function as an integrator optical system so that the light is caused to have an uniform luminance distribution. Thus, rod lens units **104a** and **104b** are not required to have any mechanism for making the light luminance distribution uniform. As a result, according to the embodiment, rod lens units **104a** and **104b** of light guide rods **134a** and **134b** can be formed short.

As described above, in the projection display device, while there are collimator lenses **151a** and **151b**, first fly-eye lens **152**, and second fly-eye lens **153**, rod lens units **104a** and **104b** of light guide rods **134a** and **134b** can be formed short. Thus, the optical unit can be miniaturized.

#### Third Embodiment

FIG. **6** is a configuration view schematically showing an internal mechanism of a projection display device according to a third embodiment of the present invention. The projection display device according to the embodiment is similar in configuration to the projection display device of the first embodiment except for a configuration described below.

In the projection display device according to the embodiment, mirror coats **241a** and **241b** are applied on side faces of rod lens units **204a** and **204b** of light guide rods **234a** and **234b**.

In the projection display device, lights emitted from light sources **201a** and **201b** are transmitted through color wheel **202**, and then totally reflected by prism units **203a** and **203b** to enter one of the ends of rod lens units **204a** and **204b**. The lights that have entered rod lens units **204a** and **204b** are transmitted through rod lens units **204a** and **204b** to exit from the other ends. Rod lens units **204a** and **204b** repeatedly reflect, during transmission of the lights from one of the ends to the other end, the lights by the side faces having mirror coats **241a** and **241b** so as to cause the light to have an uniform luminance distributions.

In the case in which no mirror coat is applied on the side faces of the rod lens units, when the side faces of the rod lens units are stained, the lights transmitted through rod lens units are discharged out of the rod lens units without being totally reflected by the side faces of the rod lens units. Thus, management is extremely important to maintain the light guide rods in an unstained state.

However, in the projection display device according to the embodiment, mirror coats **241a** and **241b** are applied to the side faces of rod lens units **204a** and **204b**. This prevents the lights from being discharged out of the side faces of rod lens units **204a** and **204b** even when the side faces are stained. Thus, management of light guide rods **234a** and **234b** is easy. In the projection display device, light loss during transmission through rod lens units **204a** and **204b** can be reduced. As a result, a bright image can be displayed.

#### Fourth Embodiment

FIG. **7A** is a configuration view schematically showing an internal mechanism of a projection display device according

to a fourth embodiment of the present invention. The projection display device according to the embodiment is similar in configuration to the projection display device of the first embodiment except for the configuration described below.

The projection display device according to the embodiment includes, in place of light guide rods **304a** and **304b** of the first embodiment shown in FIG. **3B**, prisms **303a** and **303b** corresponding to prism units **3a** and **3b**, and light tunnels **304a** and **304b** corresponding to rod lens units **4a** and **4b**.

Prisms **303a** and **303b** are glass members where slopes **331a** and **331b** are formed. Light tunnels **304a** and **304b** are cylindrical members formed by combining four rectangular planar mirrors with mirror surfaces set inside.

In the projection display device, lights emitted from light sources **301a** and **301b** are transmitted through color wheel **302**, and then are totally reflected by slopes **331a** and **331b** of prisms **303a** and **303b** to enter one of the ends of light tunnels **304a** and **304b**. The lights that have entered light tunnels **304a** and **304b** are transmitted through light tunnels **304a** and **304b** to exit from the other ends. During transmission of the lights from one of the ends to the other end, the lights are repeatedly reflected by the mirror surfaces of light tunnels **304a** and **304b** so as to cause the lights to have an uniform luminance distribution.

Air has higher light transmittance properties than glass and hence light tunnels **304a** and **304b**, whose inside are hollow, enable more efficient transmittance of light than the rod lenses. In the projection display device according to the embodiment, therefore, light loss when the light luminance distributions are made uniform can be reduced. As a result, the projection display device can display a bright image.

The projection display device according to the embodiment includes, for the respective lights, two light tunnels **304a** and **304b** so as to make uniform the luminance distributions of the lights totally reflected by slopes **331a** and **331b** of prisms **303a** and **303b**. However, as shown in FIG. **7B**, the number of light tunnels can be one.

In this case, the lights totally reflected by slopes **331a** and **331b** of prisms **303a** and **303b** enter one end of light tunnel **304**. Lights that have entered the end of light tunnel **304** are made to have an uniform luminance distribution during transmission through light tunnel **304**, and exit from the other end as one light flux. Thus, light tunnel **304** functions to make the light luminance distributions uniform and to synthesize the lights emitted from light sources **301a** and **301b**.

The preferred embodiments of the present invention have been described. However, the present invention is not limited to the embodiments. Various changes understandable to those skilled in the art can be made to be the configuration and details without departing from the spirit and the scope of the invention.

#### EXPLANATION OF REFERENCE NUMERALS

- 1a, 1b** light source
- 2** color wheel
- 3a, 3b** prism unit
- 4a, 4b** rod lens unit
- 5a, 5b, 6, 8** condenser lens
- 7** planar mirror
- 9** DMD
- 10** projection display device
- 11** projection lens
- 34a, 34b** light guide rod

9

The invention claimed is:

1. An optical unit comprising:

a first light source;

a second light source located to face the first light source;

a color wheel located between the first light source and the  
5 second light source;

a first optical path conversion unit that totally reflects light  
emitted from the first light source and transmitted  
through the color wheel, and that transmits light emitted  
from the second light source to enter the color wheel;

a second optical path conversion unit that totally reflects  
10 the light emitted from the second light source and trans-  
mitted through the color wheel, and that transmits the  
light emitted from the first light source to enter the color  
wheel; and

15 an integrator optical system that makes uniform luminance  
distributions of the light totally reflected by the first  
optical path conversion unit and the light totally  
reflected by the second optical path conversion unit,  
wherein the integrator optical system includes a first inte-  
20 grator optical system into which the light that is totally  
reflected by the first optical path conversion unit enters,

10

and a second integrator optical system into which the  
light that is totally reflected by the second optical path  
conversion unit enters, and

wherein the first optical path conversion unit and the first  
integrator optical system are integrally formed, and the  
second optical path conversion unit and the second inte-  
grator optical system are integrally formed.

2. The optical unit according to claim 1, wherein each of  
the integrator optical systems includes a rod lens.

3. The optical unit according to claim 1, wherein each of  
the integrator optical systems includes a fly-eye lens.

4. A projection display device comprising:

the optical unit specified in claim 1;

an image forming element that modulates light applied  
from the optical unit based on an image signal; and

15 a projection optical system that projects the light modu-  
lated by the image forming element.

5. The optical unit according to claim 2, wherein a side face  
of the rod lens is mirror-coated.

6. The projection display device according to claim 4,  
20 wherein the image forming element comprises a DMD.

\* \* \* \* \*