



(12) **DEMANDE DE BREVET CANADIEN**
CANADIAN PATENT APPLICATION

(13) **A1**

(86) Date de dépôt PCT/PCT Filing Date: 2019/03/05
(87) Date publication PCT/PCT Publication Date: 2019/09/19
(85) Entrée phase nationale/National Entry: 2020/09/10
(86) N° demande PCT/PCT Application No.: US 2019/020671
(87) N° publication PCT/PCT Publication No.: 2019/177804
(30) Priorité/Priority: 2018/03/15 (US62/643,487)

(51) Cl.Int./Int.Cl. *G10L 15/00* (2013.01)
(71) Demandeur/Applicant:
WAYS INVESTMENTS, LLC, US
(72) Inventeur/Inventor:
GRAY, MARK EDWARD, US
(74) Agent: PNC IP GROUP PROFESSIONAL
CORPORATION

(54) Titre : SYSTEME, PROCEDURE ET APPAREIL DE FOURNITURE D'AIDE
(54) Title: SYSTEM, METHOD, AND APPARATUS FOR PROVIDING HELP

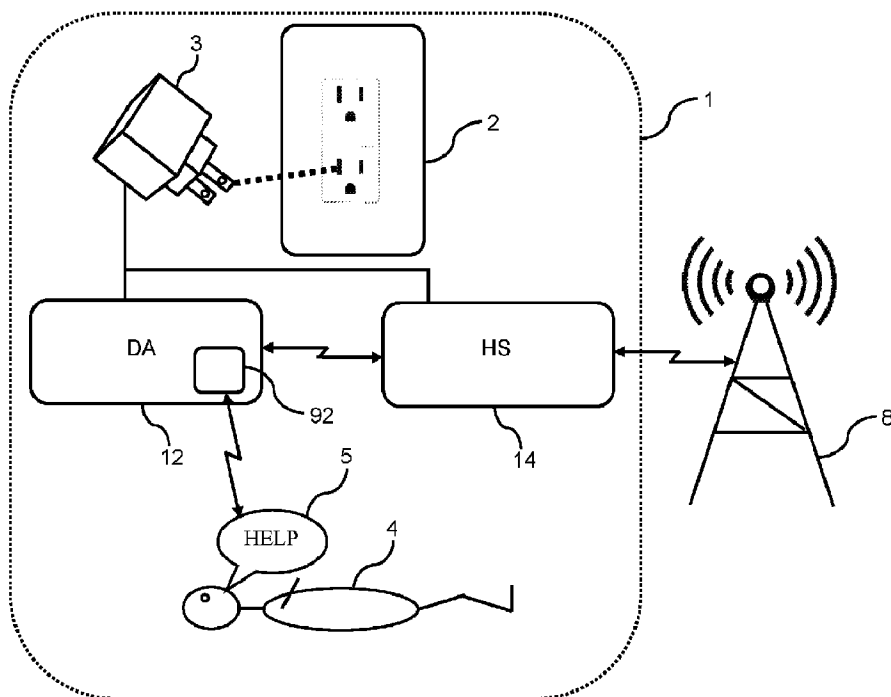

FIG. 6

(57) **Abrégé/Abstract:**

A system for providing help includes at least one digital assistant and a wireless data interface for connecting the digital assistants to a server. A plurality of agent computers is connected to the server by a data network. Each of the at least one digital assistants is

(57) **Abrégé(suite)/Abstract(continued):**

preprogrammed and centrally managed with at least one skill for recognizing a preprogrammed specific utterance and each of the at least one digital assistants is pre-configured to connect with the wireless data interface. After the preprogrammed specific utterance is detected by one of the digital assistants, that digital assistant initiates a request for help to the server and upon receiving the request for the help, the server assigns one of the agent computers and forwards the request for help to the one of the agent computers.

(12) INTERNATIONAL APPLICATION PUBLISHED UNDER THE PATENT COOPERATION TREATY (PCT)

(19) World Intellectual Property
 Organization
 International Bureau



(10) International Publication Number
WO 2019/177804 A1

(43) International Publication Date
 19 September 2019 (19.09.2019)

(51) International Patent Classification:
G10L 15/00 (2013.01)

(72) Inventor: **GRAY, Mark, Edward**; 7702 Lake Vista Court, Unit 404, Lakewood Ranch, FL 34202 (US).

(21) International Application Number:
 PCT/US2019/020671

(74) Agent: **LIEBENOW, Frank**; Larson & Larson, PA, 11199 69th Street N., Largo, FL 33773 (US).

(22) International Filing Date:
 05 March 2019 (05.03.2019)

(81) Designated States (unless otherwise indicated, for every kind of national protection available): AE, AG, AL, AM, AO, AT, AU, AZ, BA, BB, BG, BH, BN, BR, BW, BY, BZ, CA, CH, CL, CN, CO, CR, CU, CZ, DE, DJ, DK, DM, DO, DZ, EC, EE, EG, ES, FI, GB, GD, GE, GH, GM, GT, HN, HR, HU, ID, IL, IN, IR, IS, JO, JP, KE, KG, KH, KN, KP, KR, KW, KZ, LA, LC, LK, LR, LS, LU, LY, MA, MD, ME, MG, MK, MN, MW, MX, MY, MZ, NA, NG, NI, NO, NZ, OM, PA, PE, PG, PH, PL, PT, QA, RO, RS, RU, RW, SA, SC, SD, SE, SG, SK, SL, SM, ST, SV, SY, TH, TJ, TM, TN, TR, TT, TZ, UA, UG, US, UZ, VC, VN, ZA, ZM, ZW.

(25) Filing Language: English

(26) Publication Language: English

(30) Priority Data:
 62/643,487 15 March 2018 (15.03.2018) US

(71) Applicant: **WAYS INVESTMENTS, LLC** [US/US];
 7702 Lake Vista Court, Unit 404, Lakewood Ranch, FL 34202 (US).

(84) Designated States (unless otherwise indicated, for every kind of regional protection available): ARIPO (BW, GH,

(54) Title: SYSTEM, METHOD, AND APPARATUS FOR PROVIDING HELP

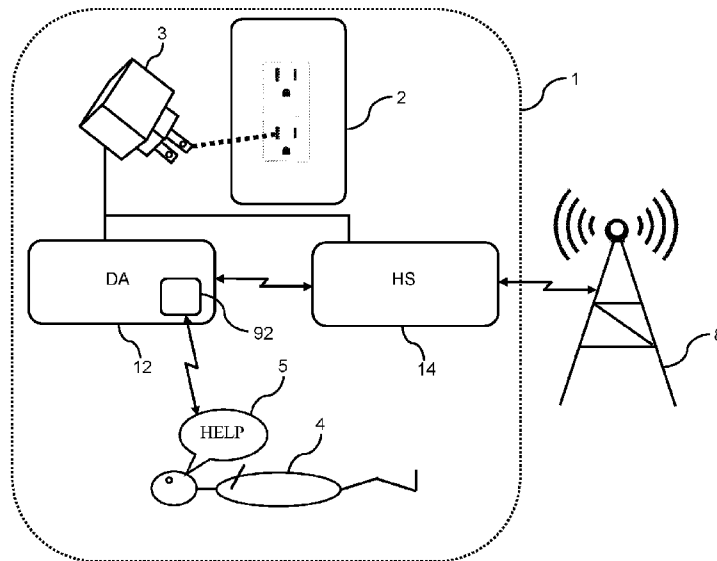

FIG. 6

(57) Abstract: A system for providing help includes at least one digital assistant and a wireless data interface for connecting the digital assistants to a server. A plurality of agent computers is connected to the server by a data network. Each of the at least one digital assistants is preprogrammed and centrally managed with at least one skill for recognizing a preprogrammed specific utterance and each of the at least one digital assistants is pre-configured to connect with the wireless data interface. After the preprogrammed specific utterance is detected by one of the digital assistants, that digital assistant initiates a request for help to the server and upon receiving the request for the help, the server assigns one of the agent computers and forwards the request for help to the one of the agent computers.



WO 2019/177804 A1

WO 2019/177804 A1 

GM, KE, LR, LS, MW, MZ, NA, RW, SD, SL, ST, SZ, TZ,
UG, ZM, ZW), Eurasian (AM, AZ, BY, KG, KZ, RU, TJ,
TM), European (AL, AT, BE, BG, CH, CY, CZ, DE, DK,
EE, ES, FI, FR, GB, GR, HR, HU, IE, IS, IT, LT, LU, LV,
MC, MK, MT, NL, NO, PL, PT, RO, RS, SE, SI, SK, SM,
TR), OAPI (BF, BJ, CF, CG, CI, CM, GA, GN, GQ, GW,
KM, ML, MR, NE, SN, TD, TG).

Published:

— *with international search report (Art. 21(3))*

System, Method, and Apparatus for Providing Help

Technical Field

This invention relates to the field of providing help to a user and more particularly to a system for requesting help for a medical or non-medical emergency by way of voice activation.

Background Art

In recent years, many companies have introduced devices that accept voice commands and take actions based upon those voice commands. Some such devices operate on smart phone, but lately, many companies are producing what is known as digital assistants which are typically stand-alone, smart speaker devices that are connected to a network (e.g. the Internet), listen for voice commands, and act on those voice commands through the network. Often, such devices utilize a keyword to initiate action. For example, one device from Amazon® is Alexa®. In order to issue a command to this device, the user must first say the keyword, "Alexa", or other optional Wake words, followed by the command. For example, "Alexa, what is the weather in Aruba today?" This keyword is important so the digital assistant does not overhear normal conversation and act on what is heard. For example, if you were on the phone and said, "did you turn off the lights," without this keyword, the digital assistant might just turn off the lights in your house. There are many uses for these digital assistants such as, reading/answering email or texts, operating connected appliances within the home, controlling the playing of music, looking up information/trivia, etc.

Unrelated to these digital assistants are medical emergencies, predicaments, or medical alerts. Many people of all ages, though concentrated on those in their golden years, run into situations in which they need help, for example, after a fall, getting stuck in a home elevator, or the onslaught of a serious medical condition such as a stroke or heart attack. If another person is in the same home or nearby, the person having the medical emergency or other hazard can shout to get that person's attention, but what about those who are alone, perhaps because others that live with them are out of the home, or they live alone. Shouting will not solicit help.

A medical alarm is an alarm system designed to signal the presence of such an event that requires urgent attention and, if needed, to summon emergency medical personnel. Other terms for a medical alarm are Personal Emergency Response System ("PERS") or medical alert. Elderly people and disabled people who live alone commonly use/require medical alarms.

Typical medical alarm systems in use today have a wireless pendant or transmitter that is activated after an event has occurred. When the transmitter is activated, a signal is transmitted and relayed to an alarm monitoring company's central station. The central station is staffed with trained personnel to assess the situation and contact other emergency agency or other programmed phone numbers. In some cases, personnel are dispatched to the site where the alarm was activated.

Such medical alarm systems work well when properly installed, when the batteries have sufficient charge and when the user remembers or agrees to wear them. However, since traditional medical alarm systems are, at least in part, user operated, there are problematic drawbacks. For example, if a user gets up in the middle of the night to go to the bathroom without their device, and falls or becomes ill and cannot reach their emergency device, or telephone; then they cannot get the emergency help they need, rendering the medical alert useless.

Furthermore, such medical alarm systems rely on user operations that requires users to change their behavior, making current medical alarm systems inherently susceptible to users' personal limitations, proclivities, and flaws – putting reliance on the user to remember to recharge the battery and consistently wear a pendant, wrist band, panic button, or other device for the entire day and night. Some users, however, do not want to wear the alarm pendant or wrist band because of aesthetics and/or inconvenience and/or privacy, rendering the device useless when needed. Also, some users forget to don or wear the device and the device may not be within reach when they need it most. Additionally, some users forget to charge the device regularly and the device simply shuts down and ceases to operate until recharged. In fact, approximately 30% of all users of such devices cancel medical alert service annually, possibly due to the fact that they no longer

wear or use the device, despite the fact that the user is still in need of a medical monitoring. In an independent research study, 83% of subscribers to medical alert services did not have their medical alert wearable device within reach in a slip and fall at home and resulted in five (5) minutes or longer stranded on the floor and unable to get up without assistance.

Additionally, as of this writing, both Amazon® Alexa® and Google Assistant® and other digital personal assistants (DPA) are not permitted to dial 911 by operating system programming. If a voice command is given to "Call for Police," "Call for a Doctor," "Call for an Ambulance," fire or other emergency is given, those commands are blocked by the other digital personal assistant, by design. One of the issues with issuing calls directly to 911 is that greater than 90% of all issued alarms from electronic alarm systems in the United States are deemed false alarms. This is a significant problem in the industry, and thus, any types of digital personal assistants are currently disabled from making unverified calls to 911.

Privacy is also of the utmost importance. In the United States, there is a set of laws commonly called HIPAA, which stands for the Health Insurance Portability and Accountability Act. HIPAA provides for stiff penalties for offenses in which medical personnel divulge any private medical information regarding a patient. Therefore, anyone involved with providing any part of a medical alarm system must be thoroughly trained and monitored to treat any information confidentially, as release of any health-related information is a possible violation of the law related to HIPAA.

As can be seen, there is a need for a system that provides help to a user that is monitored by a private, commercial system and activated by voice command thereby not requiring a personal panic button or device of any type that has to be worn by the users. Further, the system for providing help needs to install easily, provide client privacy for Protected Medical Information ("PHI"), and alert medical staff should an emergency arise.

Disclosure of Invention

The present invention relates to digital assistants and emergency communications and, more particularly, to a system for installation, configuration, and operation of a digital assistant connected to a private,

commercial system. The system for providing help is activated by voice command. In some embodiments, this triggers 2-way voice communication between agents (staff) and the user and requires no panic button or device that needs to be worn by the users.

The system for providing help includes keywords for a user to say/yell when help is needed, by simply using the appropriate voice command specified for the digital assistant, such as "Alexa, call for help." Thereby, the system for providing help enables a hands-free solution independent of any battery operated, worn electronic device. In some embodiments, the digital assistants are powered by household power, e.g. from a wall outlet, eliminating the need for a user to initiate recharging.

In other embodiments, the digital assistants are powered by a continuously recharged battery-backup base unit which gives the user several hours of battery back-up in the instance of a power outage. The battery-backup base units are powered by household power, e.g. from a wall outlet continuously eliminating the need for the user to remember to recharge them.

In other words, the system for providing help monitors and waits for a user's call for help from anywhere in their home within listening distance of one or more digital assistants. The user is not required to change their normal behavior by wearing an electronic device or worry about battery charge levels in such electronic device.

Additionally, the system for providing help is 911-non-compliant, as an agent (e.g. trained emergency professional) within the process assesses what is needed so as to facilitate the 911 call after the extent of the situation is known.

In one embodiment, a system for providing help is disclosed including at least one digital assistant and a wireless data interface for connecting the digital assistants to a server. A plurality of agent computers is connected to the server by a data network. Each of the at least one digital assistants is preprogrammed with at least one skill for recognizing a preprogrammed specific utterance and each of the at least one digital assistants is pre-configured to connect with the wireless data interface. After the

preprogrammed specific utterance is detected by one of the digital assistants, that digital assistant initiates a request for help to the server and upon receiving the request for the help, the server assigns one of the agent computers and forwards the request for help to the one of the agent computers.

In another embodiment, a method of providing help is disclosed including creating a user account which is centrally managed on behalf of the user with a unique user email and cell phone number and allocating at least one digital assistant to the user account. A provider account is created with a provider of the at least one digital assistants using the unique user email and cell phone number and a skill is preprogrammed into the at least one digital assistant that recognizes a preprogrammed specific utterance. A connectivity between each of the at least one digital assistants and a server is provided. Each of the at least one digital assistants listen for the preprogrammed specific utterance and, upon recognizing the preprogrammed specific utterance, the digital assistants sends a request for help to the server. Upon receipt of the request for the help, the server forwards the request for help to an agent computer.

In another embodiment, a turn-key system for providing help is disclosed including at least one digital assistant. Each of the at least one digital assistants is preprogrammed with at least one skill that includes recognizing a preprogrammed specific utterance (e.g. "Alexa, send help") and each of the at least one digital assistants is pre-configured, through a centrally managed account on behalf of the user, to connect with a mobile hotspot with an assigned cellular data account for high-speed Wi-Fi connection. The mobile hotspot is preprogrammed for connecting to a server. A unique user email is created, as part of the centrally managed service on behalf of the user, to protect privacy of a user of the turn-key system for providing help and a provider account created using the unique user email to protect the privacy of the user. A centrally managed account in the turn-key system for providing help for the user is provided with information for the user and the account having the unique user email. After the preprogrammed specific utterance is detected by one of the digital

WO 2019/177804 PCT/US2019/020671
assistants, one of the digital assistants initiates a request for help to the server; and upon reception of the request for help, the server assigns an agent computer and forwards the request for help to the agent computer.

Brief Description of Drawings

The invention can be best understood by those having ordinary skill in the art by reference to the following detailed description when considered in conjunction with the accompanying drawings in which:

FIG. 1 illustrates a data connection diagram of system for providing help.

FIG. 2 illustrates an alternate data connection diagram of system for providing help.

FIG. 3 illustrates a schematic view of a digital assistant of the system for providing help.

FIG. 4 illustrates a schematic view of a typical computer system.

FIG. 5 illustrates a schematic view of a typical hotspot.

FIG. 6 illustrates a view of a typical home configuration.

FIGS. 7-10 illustrate exemplary user database data.

FIG. 10A illustrates an exemplary digital assistant provider database.

FIG. 11 illustrates an exemplary system for providing help having multiple digital assistants connected to the call server using a mobile hotspot.

FIG. 12 illustrates an exemplary user database for translating between user accounts and unique addresses of the mobile hotspot.

FIGS. 13 and 14 illustrate exemplary program flows of the system for requesting help.

Best Mode for Carrying Out the Invention

Reference will now be made in detail to the presently preferred embodiments of the invention, examples of which are illustrated in the accompanying drawings. Throughout the following detailed description, the same reference numerals refer to the same elements in all figures.

Throughout this description, the term, "computer," refers to any system that has a processor and runs software. One example of such is a personal computer. The term, "digital assistant," refers to any device that

interprets voice commands and takes action or responds to those commands, for example, but not limited to, the Alexa® device from Amazon®, the Google® Home device, smartphones, etc. The term, "user," refers to a human that interfaces with the digital assistant through voice commands. The term, "agent," refers to a person who receives notice of an issue with the user and determines the appropriate next step, for example, sending help or calling emergency services (e.g. 911 or direct dispatch of emergency services from the appropriate nearby first responder agency on behalf of the user.

Referring to FIG. 1 illustrates a data connection diagram of the exemplary system for providing help. In this example, agent computers 10 (e.g., personal computers) communicates through a first network 506A (e.g. the Internet, local area network, etc.) to a call server computer 500. The agent computers 10 are staffed with agents; people who have tools for dealing with medical or non-medical emergencies such as a user falling, having a severe medical condition (e.g. stroke or heart attack), or being stuck in an elevator.

The call server computer 500 (e.g. a computer, a server or an array of servers or computers) provides access security, allowing only those agents that are authorized to access the call server computer 500, and therefore, to process incoming calls.

Although one path between the agent computers 10 and the call server 500 is through the first network 506A as shown, though any known data path is anticipated. For example, a local area network, Wi-Fi combined with a wide area network, which includes the Internet.

The call server computer 500 transacts with the agent computers 10 through the first network(s) 506A, presenting information regarding incoming requests for help, as permitted by privacy rules. In some embodiments, a two-way voice communication is set up between the agent computer 10 and the digital assistant 12 that initiated the request for help. In some embodiments, the agent computers 10 and/or the call server 500 are equipped with tools to facilitate obtaining the proper help in response to the request for help including dispatch of private staff to the residence and

escalation contacts up to and including a connection to emergency services (e.g. 911).

The call server computer 500 (and/or the agent computers 10) has access to data storage 502. In some embodiments, the data storage includes a database, or managed account database, that contains data for each user and, preferably, anonymizes the user's identity to the digital assistant providers as well as to potential hackers of the digital assistants 12. The database contains data used in routing from the digital assistants 12 to the agent computers 10, historical data such as information regarding prior requests from the same location (digital assistants 12), call logging such as dates, times, durations, content, etc., and security to the users of the digital assistants 12 and access controls.

Any number of digital assistants 12 is anticipated. The digital assistants 12 monitor sound and analyze the sound for specific utterances. Of interest to the system for providing help is specific utterances that are configured to request help such as "Alexa, Call for help" or similar. In the embodiment shown, the digital assistants communicate through the second network 506B to the call server 500, typically when and after the specific utterances 5 (see FIG. 6) that request help are detected. The second network 506B is any single or combination of network technologies, including, but not limited to local area networks (e.g. Ethernet), wireless networks (e.g. Wi-Fi or 802.11x), cellular data networks (e.g. GSM, CDMA, TDMA, LTE), of any type and configuration of network(s).

In some embodiments, the digital assistant(s) 12 respond to the specific utterances 5 (e.g. "Alexa, Call for help") by interfacing with a provider server 400, a server owned and maintained by the provider of the digital assistant 12 to initiate the call. The provider server 400 has provider accounts stored in a provider data storage 402. The provider server 400 receives the request for the call from the digital assistant 12 and initiates a phone call, e.g. by Voice over IP through the network 506B to the call server 500. The call server 500 receives the call from the provider server 400 and uses a caller-id of the call access user records (e.g. from data storage 502) to determine the name, phone number, and location of the user 4; history of

this user's 4 issues; medical information regarding the user 4 (e.g. heart conditions, medications, mobility); local support staff locations and contact information (e.g. roaming staff, staff in assisted living); etc.

Referring to FIG. 2 illustrates a data connection diagram of the exemplary system for providing help using mobile hotspots 14 which are part of the centrally programmed and managed system. In this example, agent computers 10 (e.g., personal computers) communicate (as in FIG. 1) through a first network 506A (e.g. the Internet, local area network, etc.) to a call server computer 500. Although one path between the agent computers 10 and the call server 500 is through the first network 506A as shown, though any known data path is anticipated. For example, a local area network, Wi-Fi combined with a wide area network, which includes the Internet.

Although any number of digital assistants 12 is anticipated, three are shown for brevity reasons. The digital assistants 12 monitor sound and analyze the sound for specific utterances. Of interest to the system for providing help is specific utterances that are configured to request help such as "Alexa, Call for help," or similar. In the embodiment shown, two of the digital assistants connect to a first one of the mobile hotspots 14 and a single other of the digital assistants connects to a second of the mobile hotspots 14. It is anticipated that in a smaller location (e.g. home or office), a single mobile hotspot 14 is sufficient to provide connectivity to all digital assistants 12 within that location (including a single digital assistant 12), while in larger locations more than one mobile hotspot 14, connected as a repeater using the same SSID and access code, may be required to provide adequate local wireless coverage.

Each mobile hotspot 14 communicates through the cellular network 506C to the call server 500, typically when and after the specific utterances that request help are detected.

Referring to FIG. 3, a schematic view of an exemplary digital assistant 12 is shown as used as an end-point device in the system for providing help. The exemplary digital assistant 12 is a processor-based device for providing voice recognition and command execution. The present invention is in no

way limited to any particular digital assistant 12 and many other devices are anticipated that offer similar voice recognition and command execution. Such other processor-based devices that are equally anticipated include, but are not limited to, Google® Assistant series of smart speaker digital assistants, Apple's® Siri® series of smart speaker digital assistants, other smart speakers which have embodied a similar or licensed artificial intelligence powered digital assistant of any type, smart phones, cellular phones, thermostats, fitness devices, etc.

The exemplary digital assistant 12 represents a typical device used for accessing user interfaces of the system for providing help. This exemplary digital assistant 12 is shown in its simplest form. Different architectures are known that accomplish similar results in a similar fashion, and the present invention is not limited in any way to any particular system architecture or implementation. In this exemplary digital assistant 12, a processor 70 executes or runs programs in a random access memory 75. The programs are generally stored within a persistent memory 74 and loaded into the random access memory 75 when needed. In some digital assistants 12, a removable storage 88 (e.g., compact flash, SD) offers removable persistent storage. The processor 70 is any processor, typically a processor designed for phones. The persistent memory 74, random access memory 75, and removable storage slot are connected to the processor by, for example, a memory bus 72. The random access memory 75 is any memory suitable for connection and operation with the selected processor 70, such as SRAM, DRAM, SDRAM, RDRAM, DDR, DDR-2, etc. The persistent memory 74 is any type, configuration, capacity of memory suitable for persistently storing data, for example, flash memory, read only memory, battery-backed memory, etc. In some agent computers 10, the persistent memory 74 is removable, in the form of a memory card of appropriate format such as SD (secure digital) cards, micro SD cards, compact flash, etc.

Also connected to the processor 70 is a system bus 82 for connecting to peripheral subsystems such as a wireless network interface 80 (e.g. Wi-Fi), an output port 84 for driving indicators 86, and an input port 83 for

reading switch inputs 85, though there is no restriction on inputs and outputs.

In general, some portion of the persistent memory 74 and/or the removable storage 88 is used to store programs, executable code, and data, etc.

The peripherals are examples, and other devices are known in the industry such as Global Positioning Subsystems 91, the details of which are not shown for brevity and clarity reasons.

The wireless network interface 80 connects the exemplary digital assistant 12 to the second network 506B or cellular network 506C through any known or future protocol such as Ethernet, WI-FI, GSM, TDMA, LTE, etc., through a wired or wireless medium 78. There is no limitation on the type of connection used. The wireless network interface 80 provides data and messaging connections between the exemplary digital assistant 12 and the call server 500 through the second network 506B.

For receiving voice commands from a user, the digital assistant 12 has an audio input device such as a microphone or microphone array 92.

For providing responses and information, the digital assistant 12 has a transducer device or speaker 93.

Referring to FIG. 4, a schematic view of a typical call server computer system (e.g., call server 500) is shown. The example call server 500 represents a typical server computer system used as in the system for remote computer control. This exemplary call server 500 is shown in its simplest form. Different architectures are known that accomplish similar results in a similar fashion and the present invention is not limited in any way to any particular computer system architecture or implementation. In this exemplary computer system, a processor 570 executes or runs programs in a random access memory 575. The programs are generally stored within a persistent memory 574 and loaded into the random access memory 575 when needed. The processor 570 is any processor, typically a processor designed for computer systems with any number of core processing elements, etc. The random access memory 575 is connected to the processor by, for example, a memory bus 572. The random access

memory 575 is any memory suitable for connection and operation with the selected processor 570, such as SRAM, DRAM, SDRAM, RDRAM, DDR, DDR-2, etc. The persistent memory 574 is any type, configuration, capacity of memory suitable for persistently storing data, for example, magnetic storage, flash memory, read only memory, battery-backed memory, magnetic memory, etc. The persistent memory 574 is typically interfaced to the processor 570 through a system bus 582, or any other interface as known in the industry.

Also shown connected to the system bus 582 is a network interface 580 (e.g., for connecting to a data network 506X – e.g. first network 506A and/or second network 506B and/or cellular network 506C), a graphics adapter 584 and a keyboard interface 592 (e.g., Universal Serial Bus – USB). The graphics adapter 584 receives information from the processor 570 and controls what is depicted on a display 586. The keyboard interface 592 provides navigation, data entry, and selection features.

In general, some portion of the persistent memory 574 is used to store programs, executable code, data, contacts, and other data, etc.

The peripherals are examples and other devices are known in the industry such as pointing devices, touch-screen interfaces, speakers, microphones, USB interfaces, Bluetooth transceivers, Wi-Fi transceivers, image sensors, temperature sensors, etc., the details of which are not shown for brevity and clarity reasons.

Referring to FIG. 5, a schematic view of an exemplary mobile hotspot 14 is shown as used in the system for providing help. The exemplary mobile hotspot 14 is a processor-based device for providing data connectivity through the cellular network 506C. The present invention is in no way limited to any particular mobile hotspot 14 and many other devices are anticipated that offer similar connectivity.

The exemplary mobile hotspot 14 represents a typical device used for providing data connectivity using the cellular network 506C (any cellular data network is anticipated including, but not limited to, CDMA, GSM, TDMA, LTE, etc. This exemplary mobile hotspot 14 is shown in its simplest form. Different architectures are known that accomplish similar results in a similar

fashion, and the present invention is not limited in any way to any particular system architecture or implementation. In this exemplary mobile hotspot 14, a processor 970 executes or runs programs in a random access memory 975. The programs are generally stored within a persistent memory 974 and loaded into the random access memory 975 when executed. A subscriber identity module 988 (SIM or SIM card) securely stores an international mobile subscriber identity (IMSI) number and its related key, which are used to identify and authenticate subscribers on the cellular network 506C. The processor 970 is any processor, typically a processor designed for data communications. The persistent memory 974, random access memory 975, and subscriber identity module 988 are connected to the processor by, for example, a memory bus 972. The random access memory 975 is any memory suitable for connection and operation with the selected processor 970, such as SRAM, DRAM, SDRAM, RDRAM, DDR, DDR-2, etc. The persistent memory 974 is any type, configuration, capacity of memory suitable for persistently storing data, for example, flash memory, read only memory, battery-backed memory, etc.

Also connected to the processor 970 is a system bus 982 for connecting to peripheral subsystems such as a cellular network interface 980 (e.g. cellular interface) and a local wireless network interface 981 (e.g. Wi-Fi). In some embodiments, an output port 984 is provided for driving indicators 986, and an input port 983 is provided for reading switch inputs 985, though there is no restriction on inputs and outputs.

In general, some portion of the persistent memory 974 is used to store programs, executable code, and data, etc.

The peripherals are examples, and other devices are known in the industry are anticipated, the details of which are not shown for brevity and clarity reasons.

The cellular network interface 980 connects the mobile hotspot 14 to the cellular network 506C through any known or future protocol such as GSM, TDMA, LTE, etc. There is no limitation on the type of cellular connection used. The cellular network interface 980 provides data and

WO 2019/177804 PCT/US2019/020671
messaging between the exemplary mobile hotspot 14 and the cellular network 506C.

The local wireless network interface 981 connects the mobile hotspot 14 to a local wireless network through any known or future protocol such as Wi-Fi (802.11x), Bluetooth, etc. There is no limitation on the type of local wireless connection used. The local wireless network interface 981 provides data and messaging between the mobile hotspot 14 and the digital assistants 12.

Referring to FIG. 6, a view of a typical turn-key, home configuration is shown. Within the home 1 (or office or any area), a digital assistant 12 is powered, for example, by a wall transformer 3 plugged into a standard AC outlet 2. The digital assistant 12 communicates wirelessly (e.g. by Wi-Fi) with a mobile hotspot 14, shown in this example as being powered by the same wall transformer 3. It is anticipated that the components within the home 1 of FIG. 6 (except the standard AC outlet 2) be provided as a turn-key solution, each pre-configured to function properly with each other.

The mobile hotspot 14 communicates with the call server 500 through a wide area wireless network such as a cellular network 506C (a single cell tower 8 is shown as a representation of such).

In this example, a user 4 has fallen and utters the preprogrammed specific utterance 5 (e.g., "Alexa, Call for help" or similar). that is received by the microphone array 92 of the digital assistant 12. The digital assistant 12, recognizing the utterance as the preprogrammed specific utterance 5 communicates with the mobile hotspot 14 (e.g. via Wi-Fi). After receiving the communication, the mobile hotspot 14 contacts the call center server 500 through the cellular network 506C (and/or any other networks) as represented by the cell tower 8.

In some embodiments, the call center server 500 assigns an agent computer 10 and associated call center agent, connecting to that agent computer 10 and displaying information related to the user 4, by associating the caller ID number associated with the smart speaker system to the database of the provider centrally managed system, so that the agent is able to identify the name and exact location of the caller, and is able to

understand the issue and determine the extent of the emergency, should an emergency exist.

In some embodiments, the agent computer 10 is placed in voice communication with the digital assistant 12 and, as the agent speaks, digitized speech is sent from the agent computer 10 to the digital assistant 12 and the user 4 hears what the agent is saying through one or more speakers 93 of the digital assistant 12. Likewise, when the user 4 speaks, digitized speech is sent from the digital assistant 12 to the agent computer 10 and the agent hears what the user 4 is saying through one or more speakers of agent computer 10. In this way, the agent is capable of determining the identity of the caller from the centrally managed database, and determine the extent of the emergency and able to determine what course of action is needed, for example, verbal help, sending private responders (e.g. at an assisted living location), contacting an emergency response resource (e.g. calling 911 in the USA), etc.

As many users 4 that may need emergency help often lack technical skills, those users 4 that are in greatest need of the system for providing help, it is desired to provide a "turn-key" system for providing help, in that, the user 4 need not be concerned with configuring wireless networks, home internet services, phone services, smartphone app downloading, and programming a digital assistant etc. The desire is that the user 4 only need to plug in the system for providing help to a wall power outlet and the system for providing help self-configures and operates. As many users 4 have no wireless internet access, one such pre-configuration includes one or more digital assistants 12 and one or more mobile hotspots 14, pre-configured to communicate with each other to provide services of the system for providing help (in addition to other services available from the digital assistant 12 such as answering questions, playing music, etc.). In this, the digital assistant(s) 12 is/are pre-configured to connect with the mobile hotspot(s) 14, the digital assistant(s) 12 is/are preprogrammed with the preprogrammed specific utterance 5, and the digital assistant(s) 12 have a private identity 102 (see FIG. 7) that is unique and known to the call server 500 based on the proprietary centrally managed program database. By

having a private identity 102 such as 1112223333@gmail.com, the digital assistant(s) 12 do not disclose the identity of the user 4 in outside communications unless the user 4 explicitly discloses such information. Therefore, until an emergency is determined, the agent might only be provided with a first name of the user 4 for polite addressing, thereby not releasing any private information until it is determined that an emergency exists. Such identity hiding is important for HIPAA compliance.

Note that many available digital assistants 12 have a wake-up work such as "Alexa," and such has been included in the preprogrammed specific utterance 5, for example, "Alexa, Call for help." The main reason is that should someone on the radio or television say, "send help," the system for providing help need not interpret this as an emergency.

When it is determined that an emergency exists, the private identity 102 is used by the call server 500 to access user records (e.g. from data storage 502) to determine the name, phone number, and location of the user 4; history of this user's 4 issues; medical information regarding the user 4 (e.g. heart conditions, medications, mobility); local support staff locations and contact information (e.g. roaming staff, staff in assisted living); etc.

Although it is preferred to use a digital assistant 12 as a portal into the system for providing help, parallel systems are also anticipated including by phone in which the DNIS (Dialed Number Identification System) or caller ID methodology is used to determine the identity of the user, by matching the DNIS (caller ID) with the proprietary centrally managed system database, or through programming one or more phone numbers of the system for providing help into a user's smart phone.

After installation and configuration, the user 4 typically makes an initial test call using system, by saying the preprogrammed specific utterance 5, for example: "Alexa, Call For Help" or similar. Note that in this preprogrammed specific utterance 5, the first word, "Alexa," wakes up the digital assistant 12; the second word, "Call," is a command to instruct the digital assistant 12 to initiate a digital call; and the remaining words, "for help" identify the called party, which is that of a monitored security number (e.g. the call server 500).

The system for providing help maintains a monitoring center (UL approved) with trained operators preferably providing continual operation with redundant back up. The system for providing help maintains an account for each user 4, with their address, emergency contacts such as neighbors, friends, family and physicians contact numbers, and a limited medical history and specialized instructions (Protected Medical Information or "PHI"). In some embodiments, the system for providing help offers additional services and solutions to maintain contact with a user 4 on a daily basis, verify their wellbeing and operation of their digital assistant(s) 12. By removing a need for any industry standard PERS base station (which may broadcast a customer account identification number) or a PERS (mobile cellular pendant or wrist band) improved security and privacy is provided. When a phone or smartphone is used to access the system for providing help, the DNIS (Dialed Number Identification System) or Caller ID is used as a unique index into account information from a database each time a call is received from a registered user.

If a user 4 desires a body-worn device (not shown for brevity and clarity) such as a personal panic button, a pendant or a wrist band, it is anticipated that the digital assistant 12 and/or mobile hotspot 14 be configured to interface with the body-worn device and initiate an interaction with the call server 500. An agent of the system for providing help, interfaced to the call server 500, determines if the user 4 needs assistance, and, if so, summons assistance by contacting friends, neighbors or family who can help; or an ambulance if needed, fire rescue if needed, police if needed or other emergency response as warranted.

Referring to FIGS. 7, 8, 9, and 10, exemplary user databases 100 are shown. In FIG. 7, each user 4 has a private identity 102 that is unique. When a request is received by the server computer 500, the call is assigned to one of the agent computers 10 and an agent associated with that agent computer 10. As needed and allowed under privacy laws for PHI (HIPAA), the agent is provided other information regarding the user 4 who has made the request, including the name 103 of the user 4, the address 104 of the user

4, the phone number 105 of the user 4, and a date of the last request/call 106 made by the user 4.

When it is determined that an emergency exists, the private identity 102 is used by the call server 500 to access user records (e.g. from data storage 502) to determine the name, phone number, and location of the user 4. If the agent requires further information and such is needed and allowed under privacy laws, the agent gains access to medical information 114 regarding the user 4 (e.g. heart conditions, medications, mobility) as shown in FIG. 8, indexed by the private identity 102. If the agent needs further information regarding prior requests/calls and such is needed and allowed under privacy laws, the agent gains access to a history 124 of the user 4 which includes, for example, history of prior calls or other related information such as important medical events and diagnosis (e.g. hip replacement, knee scope operation, diagnosed with cancer).

If it is determined that the user 4 needs help, there is contact information 134 as shown in FIG. 10. The contact information 134 includes, for example, global contacts, local contacts, and personal contacts that are made available to the agent. Global contacts such as E911 are less effective in a distributed environment, as it is anticipated that the agent is not in the same location as the user 4, and therefore, dialing of 911 or emergency first responders by the agent will not solicit help at the location of the user 4. Local contacts as shown in FIG. 10 provide contact information (e.g. phone numbers) for emergency services that are local to the user 4 (e.g. in the same town, zip code, etc.). Local contacts also include local support staff at the location of the user 4 (e.g. roaming staff, staff in assisted living). Personal contacts (as shown in FIG. 10) include contacts of care givers and loved ones specific to the user 4 (e.g. family members, clergy, and neighbors). Note that the contact information 134 includes any way known to contact another including, but not limited to, phone numbers, addresses, email addresses, social media addresses, voice-over-IP addresses, Ai powered digital assistants (Alexa to Alexa messaging or calling or similar), etc.

In some embodiments, the private identity 102 is, or is part of, an email address, as some digital assistants 12 require an email address at registration and, most digital assistants 12 allow for multiple digital assistants 12 to be associated with a single email address used in creating the centrally managed system. Therefore, although the private identity 102 of the users 4 is shown as a 10 digit number, it is anticipated that, in some embodiments, the private identity 102 is an email address such as 1112223333@gmail.com or 1112223333@aol.com or an alpha-numeric combination such as CC1112223333, etc.

In some embodiments, the private identity 102 is, or is part of, a phone number, as some digital assistants 12 require a phone number be provided at registration and, most digital assistants 12 allow for multiple digital assistants 12 to be associated with a phone number that is used in creating a provider account used by the provider server 400. Therefore, although the private identity 102 of the users 4 is shown as a 10 digit number, it is anticipated that, in some embodiments, the private identity 102 is phone number such as 1112223333 or 1112223333 etc. In such, when the specific utterance 5 (e.g. "Alexa, Call for help") is detected by the digital assistant 12, the digital assistant 12 contacts the provider server 400 to make the call to a contact, in this example, "for help." The phone number associated with "for help" in the user's 4 contact list is the phone number of the service and the call is made by the provider server 400 to the call server 500. The provider server 400 accesses the provider account 410 of the user from the provider data storage 402 (see FIG. 10A). The call server then calls the call server 500 with the caller-id 434 from the provider account 410. The call server 500 then uses the caller-id 434 to recognize which user 4 is associated with this incoming call. Note that the provider account 410 is abbreviated for clarity reasons.

Configuration and installation of one or more digital assistants 12 in a home is a daunting task, even for the technical literate. Many intended users of the system for providing help are low on the technical literacy scale or have an ailment/disability that makes it almost impossible to setup, configure, and install the digital assistants 12 in their facility (e.g. home).

Further, many users 4 live in locations where there is no wireless local area network coverage (e.g. Wi-Fi), further requiring each user 4 to arrange Internet access and a wireless local area network coverage, for example, from a cable or fiber optic provider.

Now, assuming the user 4 arranges for installation of Internet access as well as a wireless local area network within their facility, the user 4 must activate "Phone Skills" for the digital assistant 12 and/or update a contact list to include a contact that connects with the call server. For example, if the phone skills for the digital assistant 12 require the initiation word, "call", the preprogrammed specific utterance 5 will start with "Alexa, call" or "Hey XX, call." Now the user 4 associates the remainder of the preprogrammed specific utterance 5 with an address/phone-number of the call server 500. For example, the user adds a contact of "for help" in their address book and provides the phone number (or IP address) of the server 500 as the primary contact for this contact. Therefore, the preprogrammed specific utterance 5 is, for example, "Alexa, call for help," or "Hey XX, call for help." Now the user 4 must try to initiate a request for help by saying, for example, "Alexa, call for help," or "Hey XX, call for help," and if an agent answers, they are all set. Simple? Not really. Further, the above provides for a one-way initiation of connectivity – from the digital assistant (s) 12 of the user to the call server 500. There is no way for the call server 500 to initiate contact with any equipment (e.g. Internet infrastructure and digital assistant(s) 12 within the facility of the user 4). In some embodiments, it is important to provide "heartbeat" monitoring of the digital assistant(s) 12, as should a digital assistants 12 fail, some subset of the users 4 will not know about the failure until it is too late as some users will not use their digital assistant(s) 12 for any other purpose other than requesting help.

Although examples of the preprogrammed specific utterance 5 have been in English with a known wake-up word, for example, "Alexa, call for help," or "Hey XX, call for help," it is fully anticipated that other languages as well as custom wake-up words will be deployed. Note that because the digital assistant 12 is typically listening for utterances all day long, it is wise to use a wake-up word that is uncommon. For example, if the

preprogrammed specific utterance 5 is simplified to "Get Help," false alarms might arise when watching television and an actor on the television says, "Get Help."

Some users 4 are capable of executing the steps of installing and configuring of one or more digital assistants 12. For users 4 that are not capable or desire improved coverage, a preprogrammed system is provided upon purchase or activation of a service agreement with the monitoring company. The preprogrammed system is ready to use upon activation by a user simply plugging the digital assistants 12 into an available power outlet.

It is also anticipated that the system for requesting help be implemented using a smartphone instead of or in addition to a digital assistant 12, as voice recognition is often included in many android, Microsoft® and Apple® smartphones. Three limitations are present with smartphones is that: they require recharging, in some instances must be woken by a physical activity (e.g. pressing a wake button) and most users 4 will not want to deploy a plugged-in cellphone in each room of the facility (e.g. home). Further, as each will be a fully functional smartphone, cellular providers might not offer low-cost plans for emergency use only.

To use the system for requesting help an emergency, such as the onset of symptoms of a serious illness (chest pains in the case of a heart-attack) or other, the user 4 says the preprogrammed specific utterance 5, for example, "Alexa, call for help," or "Hey XX, call for help," loudly and clearly once. In a preferred embodiment, the digital assistant 12 will respond, "Calling for Help Now". The request will be received by the call server 500 and the request will be forwarded to one of the agent computer 10 along with information of the user's 4 name and location from the centrally managed system database. A two-way voice connection is made between the agent computer 10 and the digital assistant 12 that requested help (and, in some embodiments, with other digital assistants 12 with the same facility). As an example, the agent at the agent computer 10 will ask the nature of the emergency. If the user 4 is unable to speak further, perhaps incapacitation due to the emergency or illness, the security call center detects that you made the request for help and, if unable to gain a response,

will either call E911 or local emergency first responders directly with your emergency or follow other agreed upon protocol for this user 4 (as per their account) such as contacting a private duty help agent (e.g. a roaming agent local to the user 4), assisted living staff, neighbors, etc.

In some cases, the user has fallen and is having trouble getting back up on their bed or chair etc. in this case, the user does not need E911 help, and instead, help is requested of a neighbor, friend or family member that is local to the user 4 and able to assist the user 4.

Having one or more digital assistants 12 within a facility, other uses for the digital assistants 12 are anticipated such as to remind the users 4 when it is time to take medicines, to call for a ride share service, and to access a host of other resources available with each digital assistant 12 that will enhance the quality of life and safety and well-being of the users 4.

Although disclosed for use in a facility such as a home or office, it is fully anticipated that the system for requesting help be deployed in a hospital, medical complex, group home, adult living facility or nursing home. In such, the system for requesting help is capable of replacing the Panic Button (typically tethered to the bed and useless if the user 4 falls away from the bed). In such, the user 4 of such a facility is able to initiate a request for help using the preprogrammed specific utterance 5 from anywhere local to the digital assistant 12 and, after assessing the issue, the agent will call a person at the monitoring station (e.g. nurse, orderly) or a Central Monitoring station. Further, it is fully anticipated that the system for requesting help be deployed in hotels. In guest rooms equipped with the system for requesting help, in addition to summoning help should the guest have a medical emergency, sees a fire, or is being assaulted or robbed, the digital assistant 12 will control televisions, music players, wake alarms, thermostats, etc. In such, each digital assistant 12 is associated with a room number. Likewise, it is fully anticipated that the system for requesting help be deployed in commercial or business environments providing higher security and safety, distributed throughout buildings, elevators, restrooms, etc. In some embodiments, the digital assistant 12 will identify the person speaking, as well as the location of the device, using voice recognition

technology. With such, a call for local, internal building security or E911 emergency help is provided by the agent as needed. It is fully anticipated that the system for requesting help be deployed in schools and universities having digital assistants 12 in classrooms and public spaces so that teachers or students are able to call for help if an active shooter is present or medical emergency occurs. In such, the digital assistant 12 is associated with the classroom number and/or location. It is also fully anticipated that the system for requesting help be deployed in vehicles of any type (e.g., cars, buses, airplanes, cruise ships) and such include GPS location capability. This provides help to a user 4 during, for example, a car-jacking, medical emergency, sinking vessel, etc.

Referring to FIG. 11, an exemplary system for providing help having multiple digital assistants 12 connected to the call server 500 using a mobile hotspot 14 is shown. There exists a large population of potential users of the system for providing help that have limited technical abilities and, often, no Internet access or smartphone. This subset of users likely cannot setup and install the digital assistant(s) 12, even if wireless internet is available. Further, the typical setup of a digital assistant 12 often requires a smartphone, an active email address, Wi-Fi internet access, and a service account from the digital assistant provider (e.g. Amazon® or Google®). Further, a greater level of security is desired as this subset of users often is vulnerable to various intrusions. The centrally managed service described in the system and methodology provides all the required resource in pre-programmed solution which requires no installation by the user except for plugging the system into an available power outlet(s).

Digital assistant providers require a user account and an email address. To reduce the possibility of divulging private health information, an account and email address is created and both the account name and email address is randomized as part of the centrally managed system. For example, the account name is AZ111222333 and the unique user email address is AZ111222333@provider.com. In this way, there is no disclosure of a name, social security number, address, or any other identifying information to the digital assistant provider and, therefore, even if there is a

security breach and information is made available to/by the digital assistant provider, it will not be associated with an identified person. For example, if a communication is intercepted and disclosed, it will be that user account AZ111222333 requested help due to chest pain, with no way for the digital assistant provider or perpetrator to know the identity of the user associated with the user account of AZ111222333.

Therefore, as shown in FIG. 11, each digital assistant 12 in the same facility (e.g. the home of J. Smith), has been pre-registered with the same digital assistant provider account 152 (e.g. AZ111222333).

In this, if the user 4 already has wireless data access (e.g. Wi-Fi), one anticipated option is to provide one or more digital assistants 12 that are preprogrammed and setup with that user's account (e.g. AZ111222333). This still requires each digital assistant 12 to recognize the user's 4 private wireless network, typically requiring a smartphone to provide a network access password to each digital assistant 12.

To further simplify both operation and installation, an improved anticipated option is to provide a turn-key system for providing help as shown in FIG. 11, having one or more digital assistants 12 pre-configured and pre-connected to a mobile hotspot 14. In this, each digital assistant 12 is associated with a digital assistant provider account 152, each digital assistant 12 is preprogrammed with the preprogrammed specific utterance 5, and each digital assistant is pre-configured to connect to the call server 500 through the mobile hotspot 14. In addition, the mobile hotspot 14 has a unique address 150, typically known as a MAC address. When a request is received by the call server 500, the call server 500 is aware of the unique address 150 and, for example, using a translation table as shown in FIG. 12, the call server 500 is able to determine to source of the request (e.g. name 103 of requester and the account number 102 of the requester).

Further, by having the unique address 150 of each mobile hotspot 14 assigned to the user 4, additional features are enabled. One feature that is anticipated is a polling feature to make sure each mobile hotspot 14 and associated digital assistants 12 are functioning properly. For example, once per day or once per hour, the call server 500 establishes a connection to

each digital assistant 12, enabled by the centrally managed system. If the connection fails, this signals a potential hardware problem and service is performed. Another feature anticipated is outward calling to each user 4. In this, the call server 500 makes an unsolicited call to the digital assistants 12 and solicits a verbal answer (e.g., "Hello J. Smith, is everything OK?"). If the appropriate verbal answer (e.g. "Yes," or "Alexa Yes") is not received within a predetermined time period, appropriate action takes place such as calling the user 4 by phone, dispatching private staff, contacting loved ones or neighbors, etc.

It is further anticipated that some portion of the user's 4 address is programmed into the user's account to enable digital assistant features that are location specific (e.g., "what is the weather?" or "what is playing at nearby movie theatres?"). It is also anticipated that if the user 4 has a smartphone, the user's smartphone be programmed with the user's account information so that the user has the ability to adjust the digital assistant, for example, by adding skills, contacts, etc.

Referring to FIGS. 13 and 14, exemplary program flows of the system for requesting help are shown. In FIG. 13, a new digital assistant 12 and mobile hotspot 14 are being programmed. The first step is to get 200 a digital assistant(s) 12 and mobile hotspot 14. Now a new account is generated 202 (e.g. in the data storage 502 of the call server 500), creating the private identity 102 of the user 4 and adding user information such as the name 103 of the user 4, address 104, phone number 105, medical situations and medication information 114, and contact information 134 (e.g. local emergency contacts, neighbors, dedicated staff, private staff, etc.

Now the account is created 204 at the provider of the digital assistant 12 using private identity 102 of the user 4 and other information, for example, including minimal identifying information of the user 4 such as zip code or possibly street name, but not street number.

The mobile hotspot 14 is associated 206 with the new account, adding a unique identifier/address of the mobile hotspot 14 (e.g., MAC address and/or phone number) to the new account and, therefore, associating the mobile hotspot 14 with the new account of the user 4. Note that each mobile

hotspot 14 has a unique address to the cellular network 506C, typically a phone number to which the call server 500 is able to address uniquely, for example, by sending a text message to this phone number.

Next, each digital assistant 12 is configured to communicate with the mobile hotspot 14 and to include the skills needed to provide the system for requesting help (e.g. at a minimum, the skill to recognize the preprogrammed specific utterance 5, for example, "Alexa, call for help," or "Hey XX, call for help"). As it is anticipated that a single user have one or more digital assistants 12, likely depending upon the size and layout of the facility of the user 4 (e.g. home), a loop begins with the first 210 digital assistant 12. The digital assistant 12 is programmed to be centrally managed by the provider and associated 212 with the mobile hotspot 14. The programming includes adding the skills needed to provide the system for requesting help (e.g. at a minimum, the skill to recognize the preprogrammed specific utterance 5). The association includes setting up the digital assistant 12 to properly communicate with the mobile hotspot 14. If this is the last 214 digital assistant 12 for the user 4, the digital assistant(s) 12 and mobile hotspot(s) 14 are delivered/sold 220 to the user 4 and the process is complete. If this is not the last 214 digital assistant 12, the next 216 digital assistant 12 is selected and the above steps 212/214 repeat.

In FIG. 14, a polling loop is shown, as the system for requesting help is enabled to provide monitoring of the premise equipment (e.g. digital assistant(s) 12 and mobile hotspot(s) 14). In order to provide such monitoring, the call server 500 (or other computer) needs the ability to connect to the premise equipment. In prior systems, this ability was not present, so there was no ubiquitous way to check and make sure each user's premise equipment was functioning. Now, using the mobile hotspots 14 and maintaining an address of each mobile hotspot 14, the system for requesting help is enabled to periodically reach out and make sure the premise equipment is functioning and/or make sure the user 4 is responsive.

Testing of the mobile hotspots 14 is easily performed by sending a text message to the phone number associated with each mobile hotspot 14, but this does not address each digital assistant 12.

For fully end-to-end testing, each digital assistant 12 associated with an account establishes a connection with the call server 500 (or other computer in the system) during initialization (power-up). Therefore, a user 4 that has three digital assistants 12 will have three active connections to the call server 500.

Polling of each digital assistant 12 on a list of digital assistants to poll is performed at a selected time or times of each day, for example, every day at 2:00PM. At that time, the account on the list 240 is selected and a loop begins selecting the first 242 digital assistant 12 for the account. The account is accessed in the database to get the connection handle (e.g. connection id) and the connection is checked 244 to make sure there was no disconnect. If the digital assistant 12 is not connected 246, an escalation 248 is performed and the loop continues. The escalation 248 is, for example, an agent determines if other digital assistants 12 at the user's 4 premise are working, calls the user 4 by phone, contacts a neighbor of the user 4, contacts a provider local to the user 4, etc.

If the digital assistant 12 is connected 246, a flag is checked in the account to determine if the user 4 is configured to receive a voice prompt 250. If the user 4 is configured to receive a voice prompt 250, the voice prompt is made 252 (e.g. a verbal request such as "Good afternoon Mr. Smith. Please respond with a yes."). If the user 4 does not respond 254 with a verbal answer "yes," (perhaps within a given time allotment, the above escalation 248 is performed and the loop continues.

If the user 4 responds 254 with a verbal "yes," or "Alexa yes," the loop continues with determining if this digital assistant 12 is the last 256 digital assistant. If this digital assistant 12 is the last 256 digital assistant, the polling for this account is performed (e.g., polling for the next account is now performed, if any). If this digital assistant 12 is not the last 256 digital assistant, the next digital assistant 258 is selected and the loop continues.

Equivalent elements can be substituted for the ones set forth above such that they perform in substantially the same manner in substantially the same way for achieving substantially the same result.

It is believed that the system and method as described and many of its attendant advantages will be understood by the foregoing description. It is also believed that it will be apparent that various changes may be made in the form, construction and arrangement of the components thereof without departing from the scope and spirit of the invention or without sacrificing all of its material advantages. The form herein before described being merely exemplary and explanatory embodiment thereof. It is the intention of the following claims to encompass and include such changes.

Claims:

1. A system for providing help, the system comprising:
 - at least one digital assistant;
 - a wireless data interface for connecting the digital assistants to a server;
 - a plurality of agent computers, each of the plurality of agent computers connected to the server by a data network;
 - whereas each of the at least one digital assistants is preprogrammed with at least one skill, the at least one skill including the skill for recognizing a preprogrammed specific utterance and each of the at least one digital assistants is pre-configured to connect with the wireless data interface;
 - whereas after the preprogrammed specific utterance is detected by one of the digital assistants, the one of the digital assistants initiates a request for help to the server; and
 - whereas after receiving the request for the help, the server assigns one of the agent computers and forwards the request for the help to the one of the agent computers.
2. The system of claim 1, wherein the wireless data interface is a mobile hotspot.
3. The system of claim 2, wherein the at least one digital assistant is pre-configured to automatically connect to the mobile hotspot.
4. The system of claim 1, wherein privacy is protected by assigning a generated, unique user email address, to identify an account associated with the at least one digital assistant.
5. The system of claim 4, wherein a user account is created with a provider of the at least one digital assistant using the unique user email address, thereby shielding from disclosure of identifying information to the provider of the at least one digital assistant.

6. The system of claim 1, wherein each of the at least one digital assistant automatically connects to the server through the wireless data interface.
7. The system of claim 6, wherein the server periodically confirms that the at least one digital assistant remains connected to the server and if the at least one digital assistant is found not to be connected to the server, the server initiates an escalation.
8. The system of claim 7, wherein if the at least one digital assistant is found to be connected to the server, the server initiates a vocal request to at least one of the digital assistants and if the at least one of the digital assistants does not receive a verbal answer to the vocal request within a predetermined time period, the server initiates the escalation.
9. A method of providing help, the method comprising:
 - creating a user account and a unique user email;
 - allocating at least one digital assistants to the user account;
 - creating a provider account with a provider of the at least one digital assistants using the unique user email;
 - preprogramming a skill into the at least one digital assistant, the skill recognizing a preprogrammed specific utterance;
 - providing a connectivity between each of the at least one digital assistants and a server;
 - listening for the preprogrammed specific utterance by each of the at least one digital assistants and, upon recognizing the preprogrammed specific utterance by one of the at least one digital assistants, the one of the at least one digital assistants sending a request for help to the server; and
 - upon receiving the request for the help, the server forwarding the request for help to an agent computer.
10. The method of claim 9, wherein the connectivity between each of the at least one digital assistants and the server includes a mobile hotspot.

11. The method of claim 10, wherein the mobile hotspot and each of the at least one digital assistants are preprogrammed to connect to each other.
12. The method of claim 9, further comprising the steps of:
 - upon initialization, each of the at least one digital assistants connects to the server.
13. The method of claim 12, further comprising the steps of:
 - periodically determining if each of the at least one digital assistants is connected to the server and any of the at least one digital assistants is disconnected from the server, initiating an escalation.
14. The method of claim 13, further comprising the steps of:
 - if all of the at least one digital assistants is connected to the server, sending a vocal request to at least one of digital assistants and waiting for a predetermined time period for a vocal answer; if the vocal answer is not detected within the predetermined time period, initiating the escalation.
15. A turn-key system for providing help, the system comprising:
 - at least one digital assistant; each of the at least one digital assistants is preprogrammed with at least one skill, the at least one skill including recognizing a preprogrammed specific utterance and each of the at least one digital assistants is pre-configured to connect with a mobile hotspot;
 - the mobile hotspot is preprogrammed for connecting to a server;
 - a unique user phone number created to protect privacy of a user of the turn-key system for providing help;
 - a provider account created using the unique user phone number to protect the privacy of the user;
 - an account in the turn-key system for providing help for the user, the account having information for the user and the account having the unique user phone number;

whereas after the preprogrammed specific utterance is detected by one of the digital assistants, the one of the digital assistants initiates a call for help and a call is made to the server having a caller-id of the unique user phone number; and upon reception of the call, the server recognizes the unique user phone number and assigns an agent computer and forwards the request for help to the agent computer.

16. The turn-key system of claim 15, wherein each of the at least one digital assistant automatically connects to the server through the mobile hotspot.

17. The turn-key system of claim 16, wherein the server periodically confirms that the at least one digital assistant remains connected to the server and if the at least one digital assistant is found not to be connected to the server, the server initiates an escalation.

18. The turn-key system of claim 17, wherein if the at least one digital assistant is found to be connected to the server, the server initiates a vocal request to at least one of the digital assistants and if the at least one of the digital assistants does not receive a verbal answer to the vocal request within a predetermined time period, the server initiates the escalation.

19. The turn-key system of claim 15, wherein the account in the turn-key system for providing help for the user is indexed by the unique user phone number and the account includes an address of the user, health of the user, medications prescribed for the user, and contacts for local help related to the user.

20. The turn-key system of claim 15, wherein the contacts for local help related to the user comprise a one or more contacts selected from the group consisting of a contact for a relative, a contact for local emergency medical services, a contact for local police, a contact of a relative, a contact of a clergy, a contact of a local fire department, and a contact of staff assigned to the user.

1/15

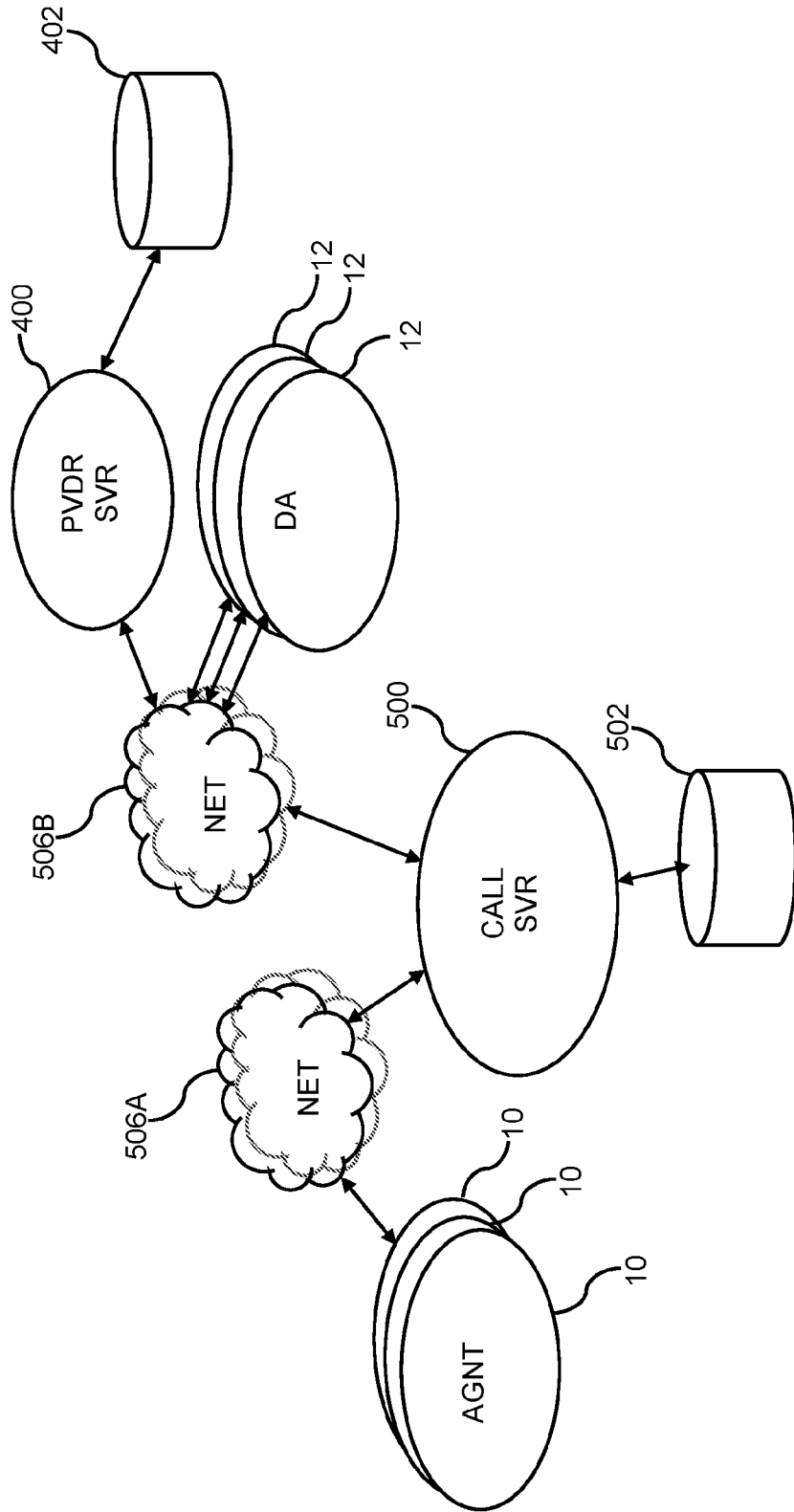

FIG. 1

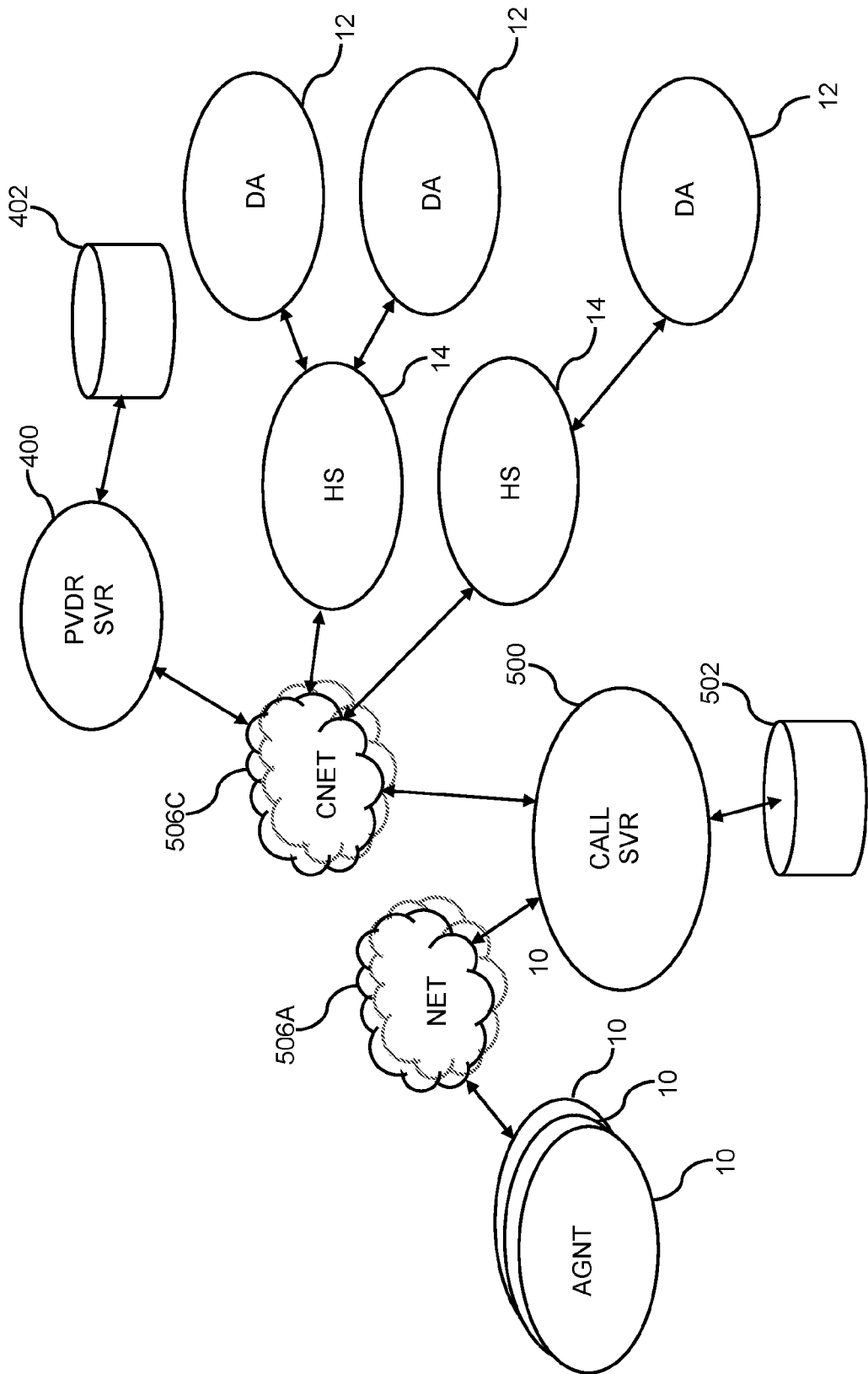

FIG. 2

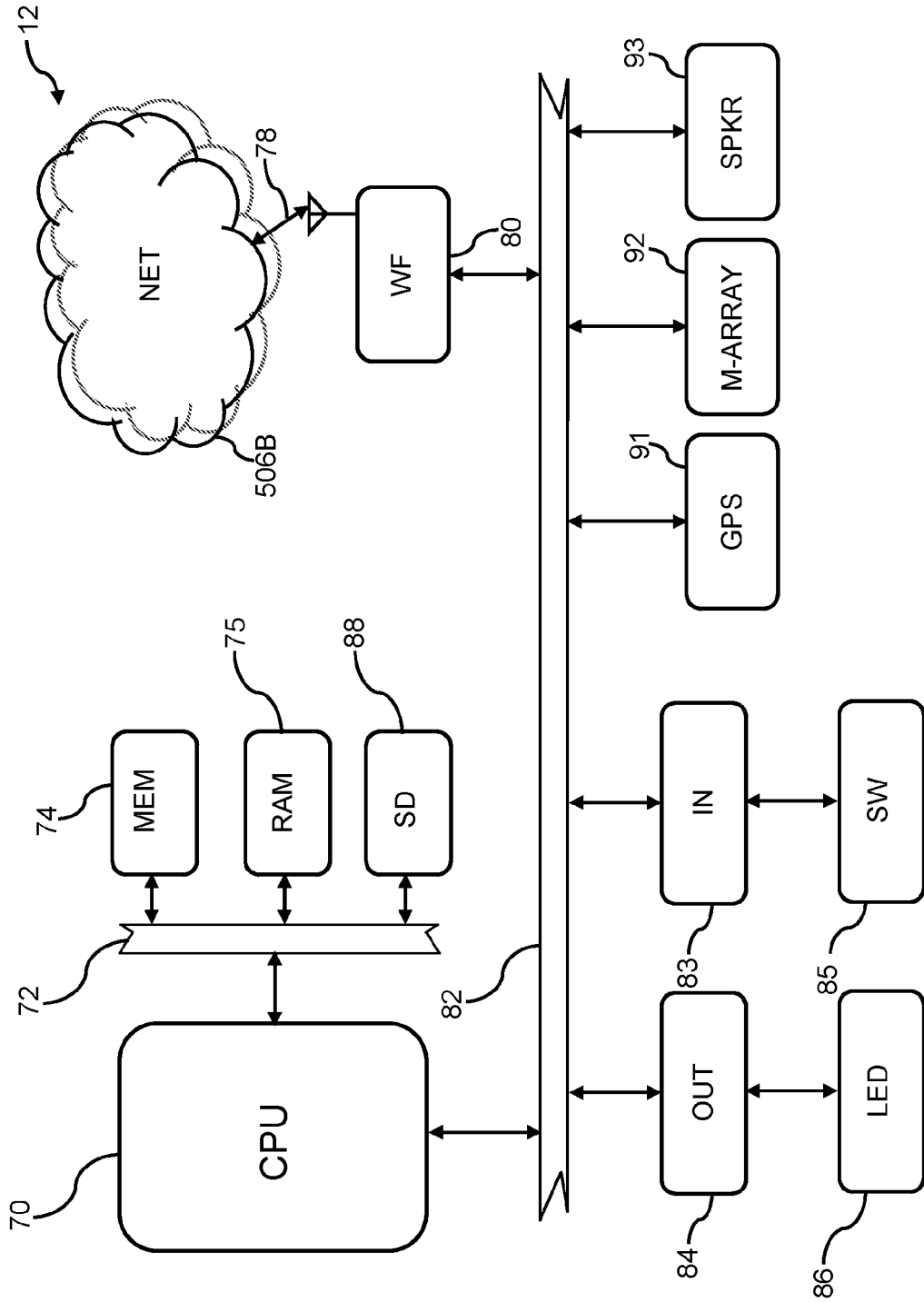

FIG. 3

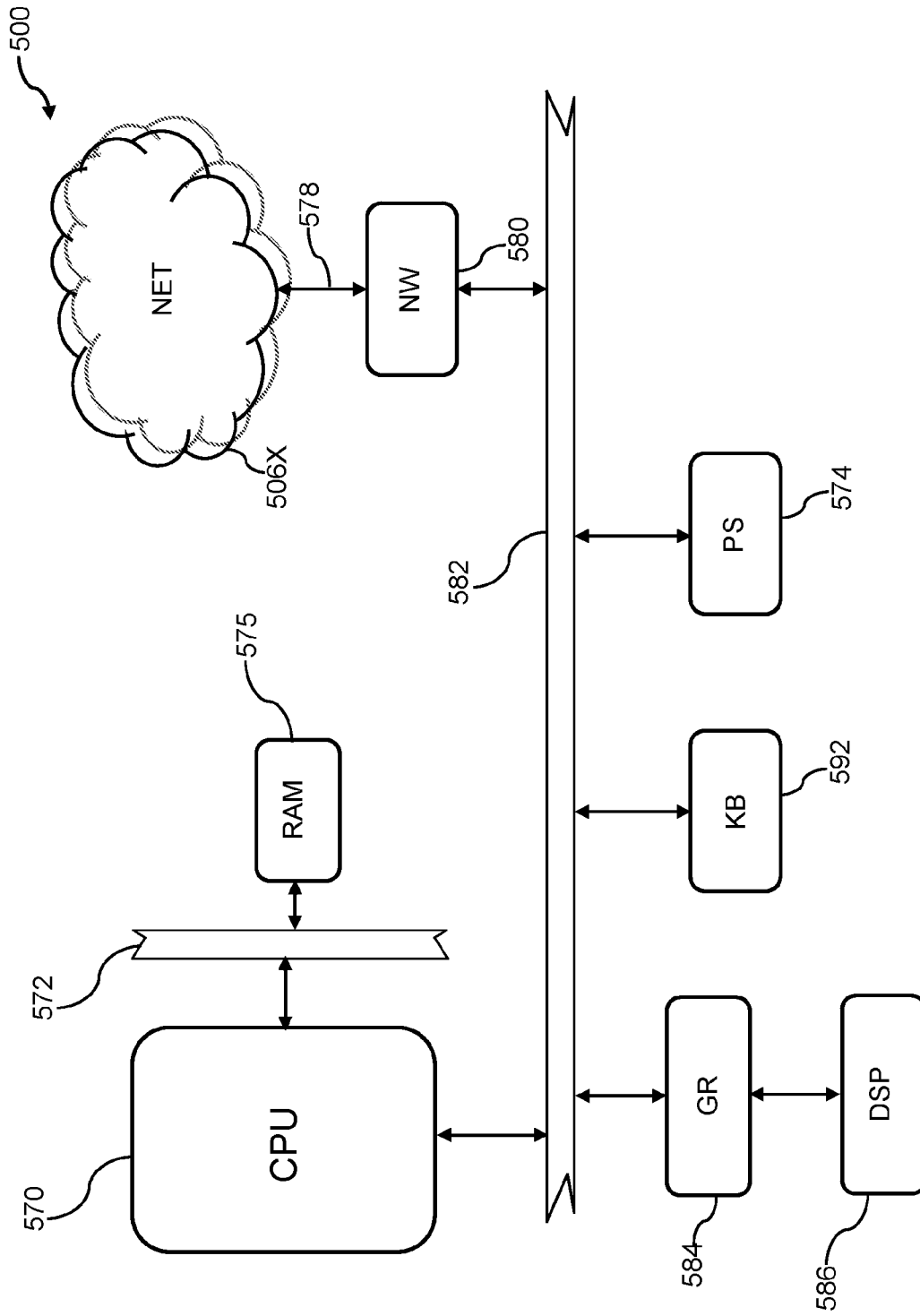

FIG. 4

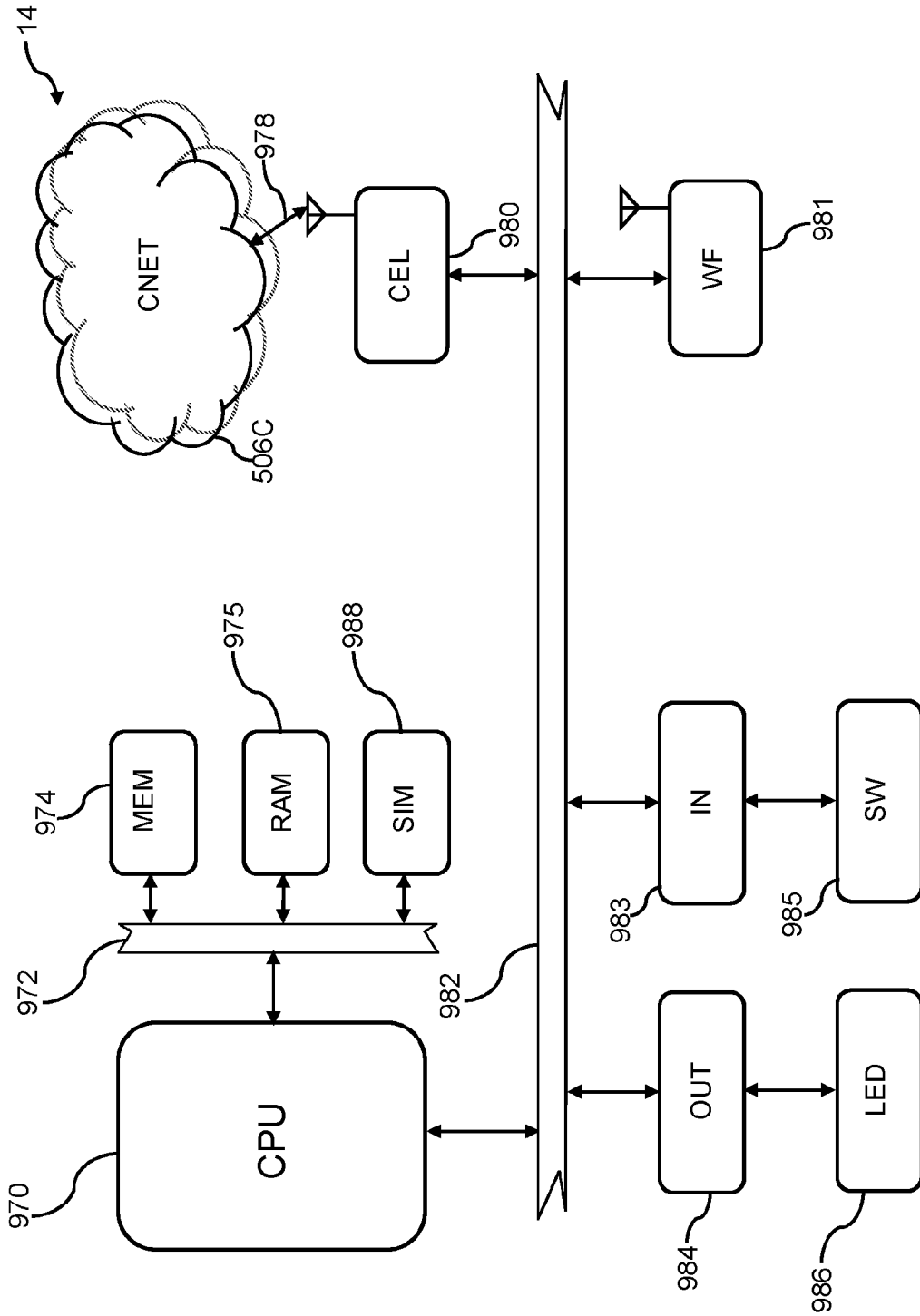

FIG. 5

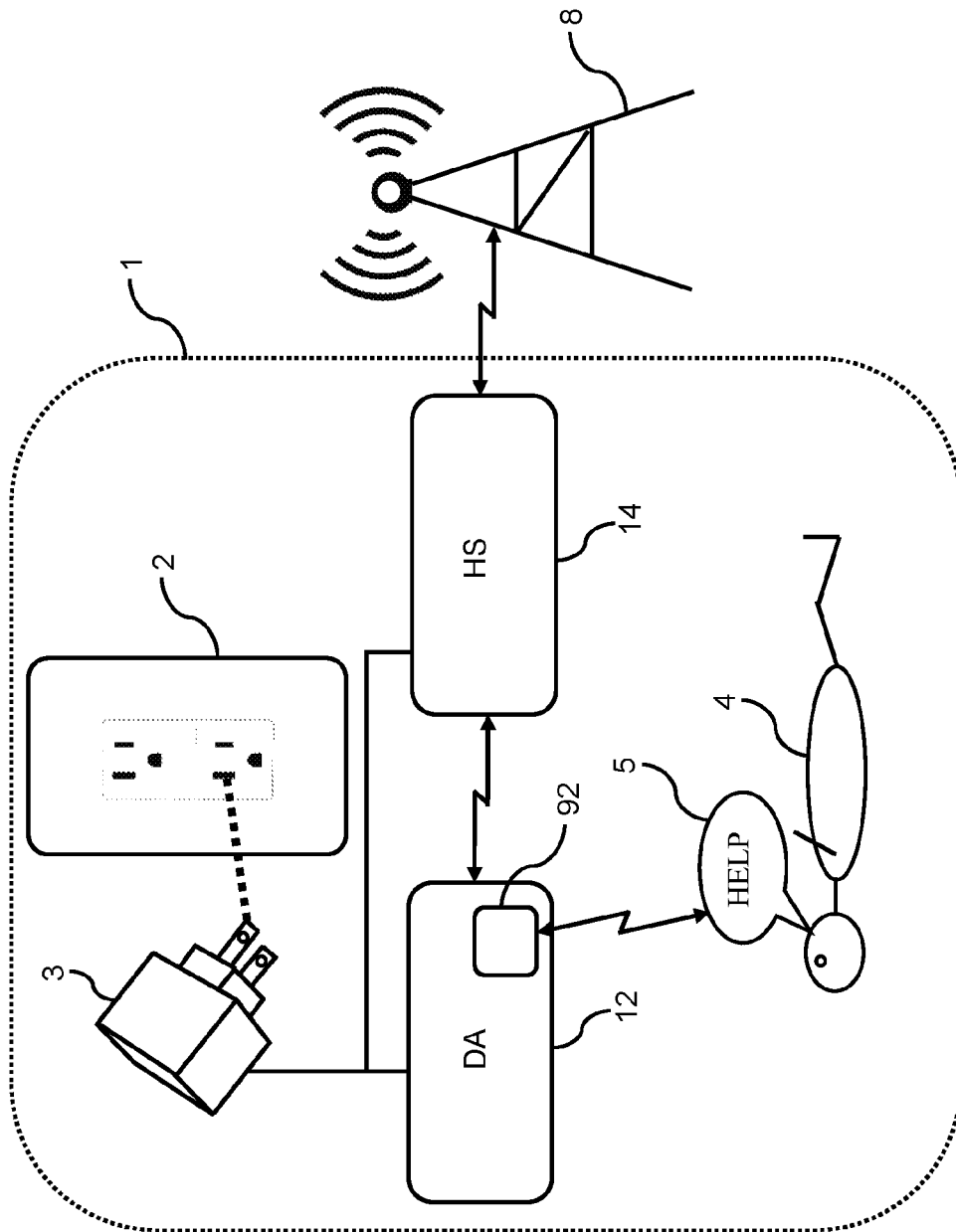

FIG. 6

102	103	104	105	106
USER PVT ID	NAME	ADDR	PHONE	LAST
1112223333	Smith, J	1313 MB LN	555-555-1212	3/1/18
1112224444	Smith, M	1313 MB LN	555-554-1212	3/1/18
1112225555	Smith, H	1313 MB LN	555-555-1212	3/1/18

FIG. 7

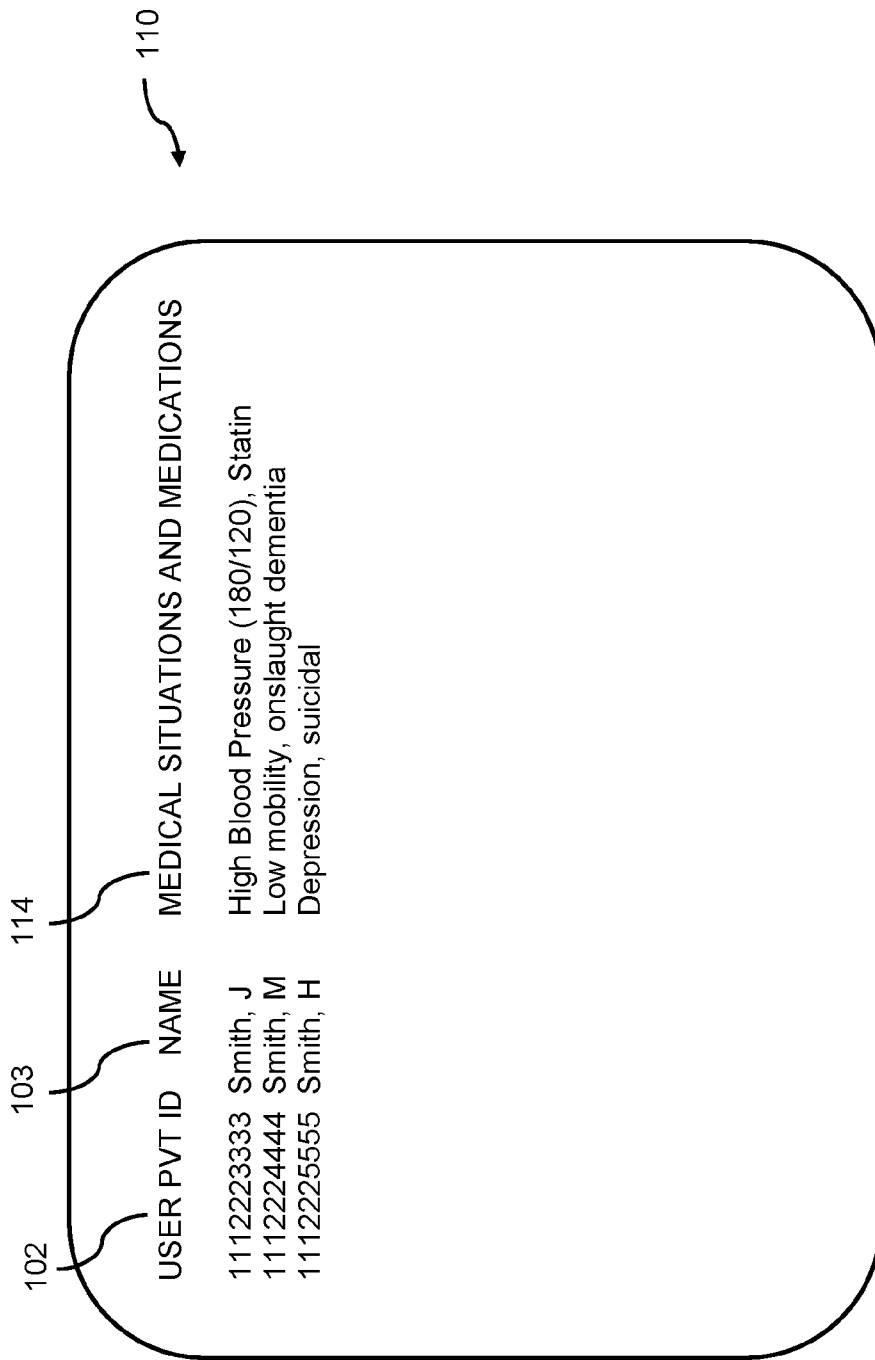

FIG. 8

9/15

USER PVT ID	NAME	HISTORY
1112223333	Smith, J	3/1/2018 call, no action 3/5/2018 call, summoned EMS
1112224444	Smith, M	2/5/2018 call, summoned fire – stuck in elev. 4/1/2018 operation – left hip replacement 5/1/2018 call, fall, summoned fire & EMS
1112225555	Smith, H	3/13/2018 call, suicidal, transferred to hot line 3/18/2018 call, suicidal, summoned police

FIG. 9

The diagram shows a table with three columns. The first column is labeled 'USER PVT ID' with reference numeral 102. The second column is labeled 'NAME' with reference numeral 103. The third column is labeled 'CONTACTS' with reference numeral 134. A bracket on the right side of the table groups the three rows under the label 'CONTACTS'. The table contains the following data:

USER PVT ID	NAME	CONTACTS
1112223333	Smith, J	555-555-1212 local EMS 555-555-1212 local police 555-555-1212 staff at XX assisted living 555-555-1212 personal - Sister 555-555-1212 local fire department
1112224444	Smith, M	555-555-1212 personal - Son daughter@gmail.com personal - Daughter 555-555-1212 local police
1112225555	Smith, H	555-555-1212 Priest 555-555-1212 Counselor 555-555-1212 Preferred Suicide hotline 555-555-1212 local police

FIG. 10

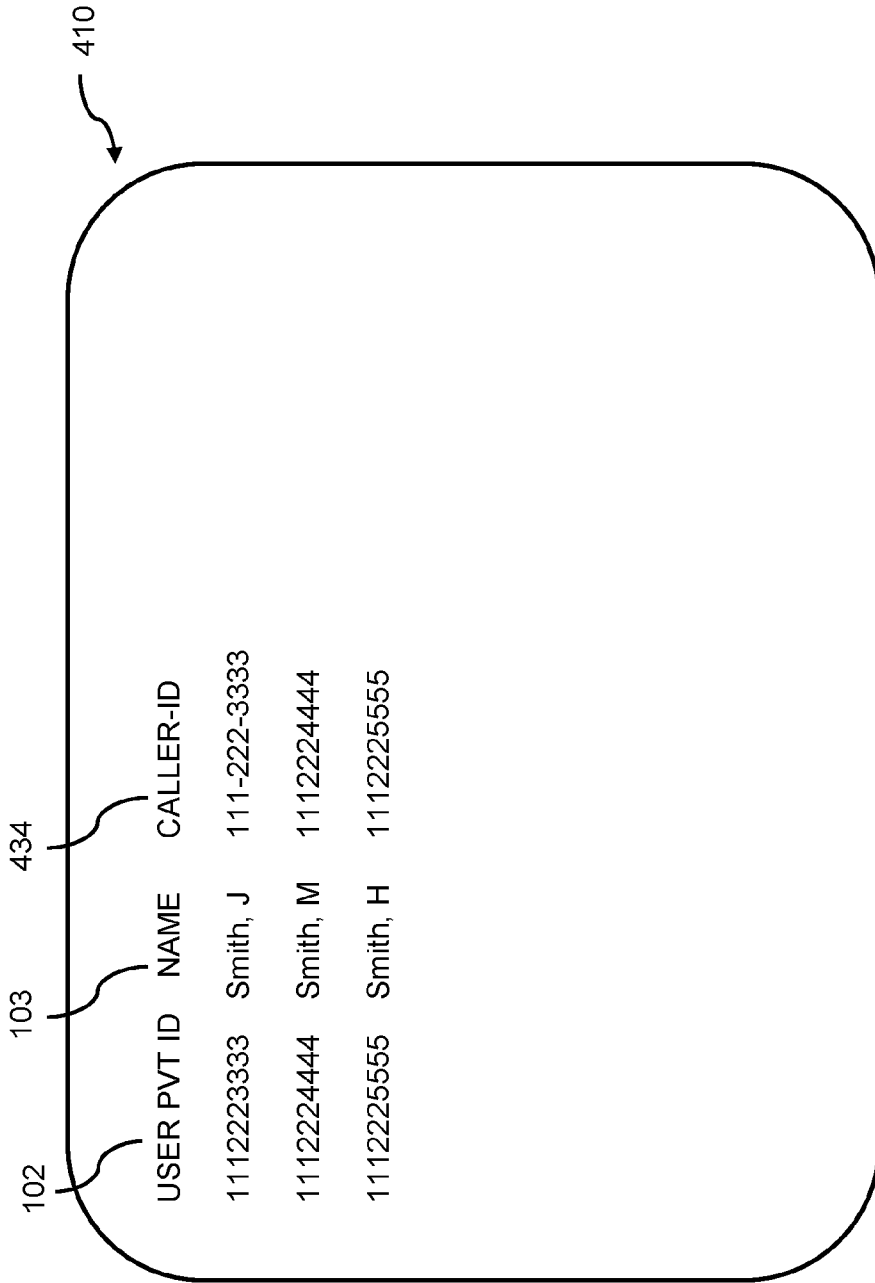

FIG. 10A

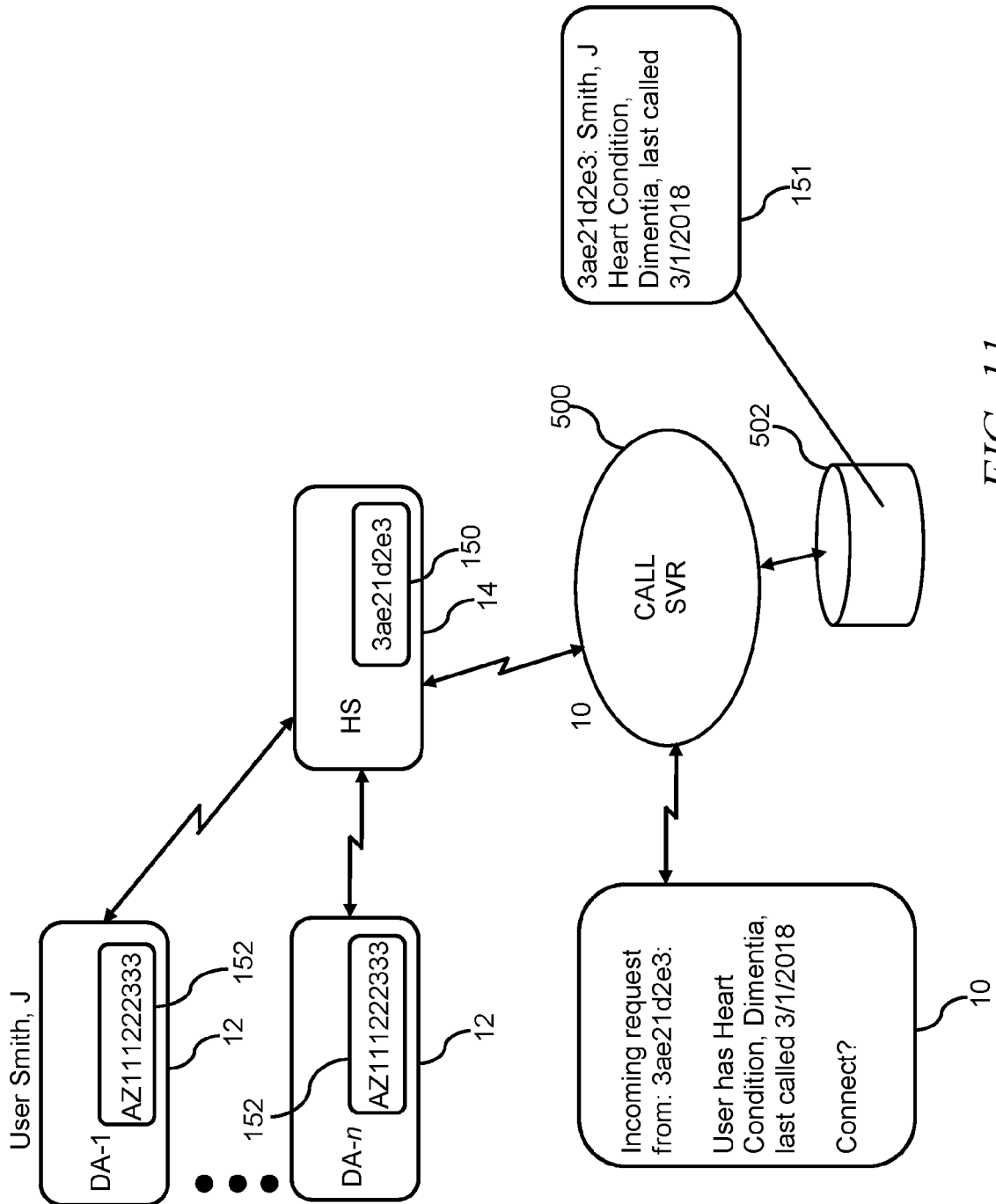

FIG. 11

USER PVT ID	NAME	IP ADDR
1112223333	Smith, J	3ae21d2e3
1112224444	Smith, M	4ae99d2e3
1112225555	Smith, H	3cc21dfff

FIG. 12

14/15

FIG. 13

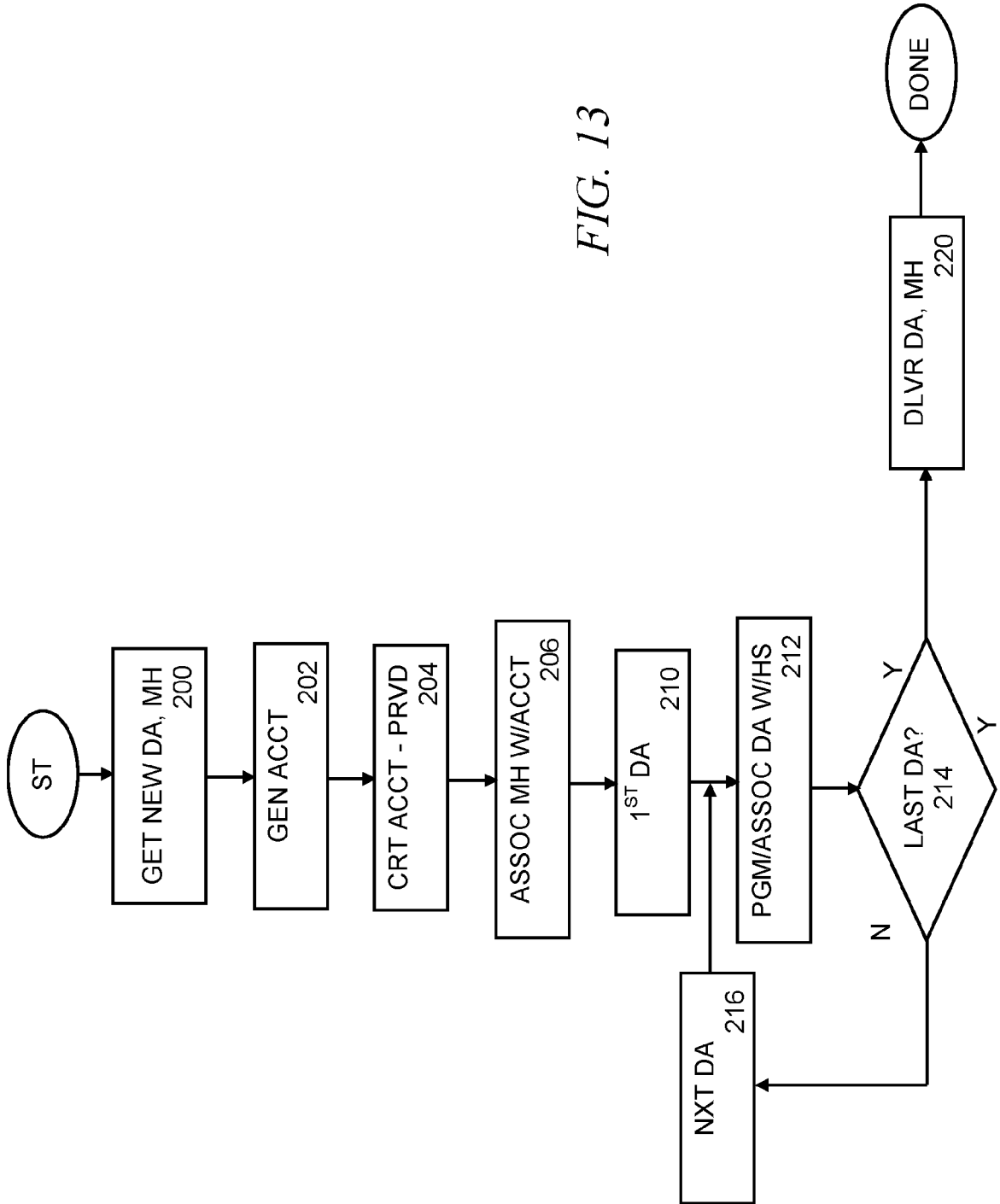

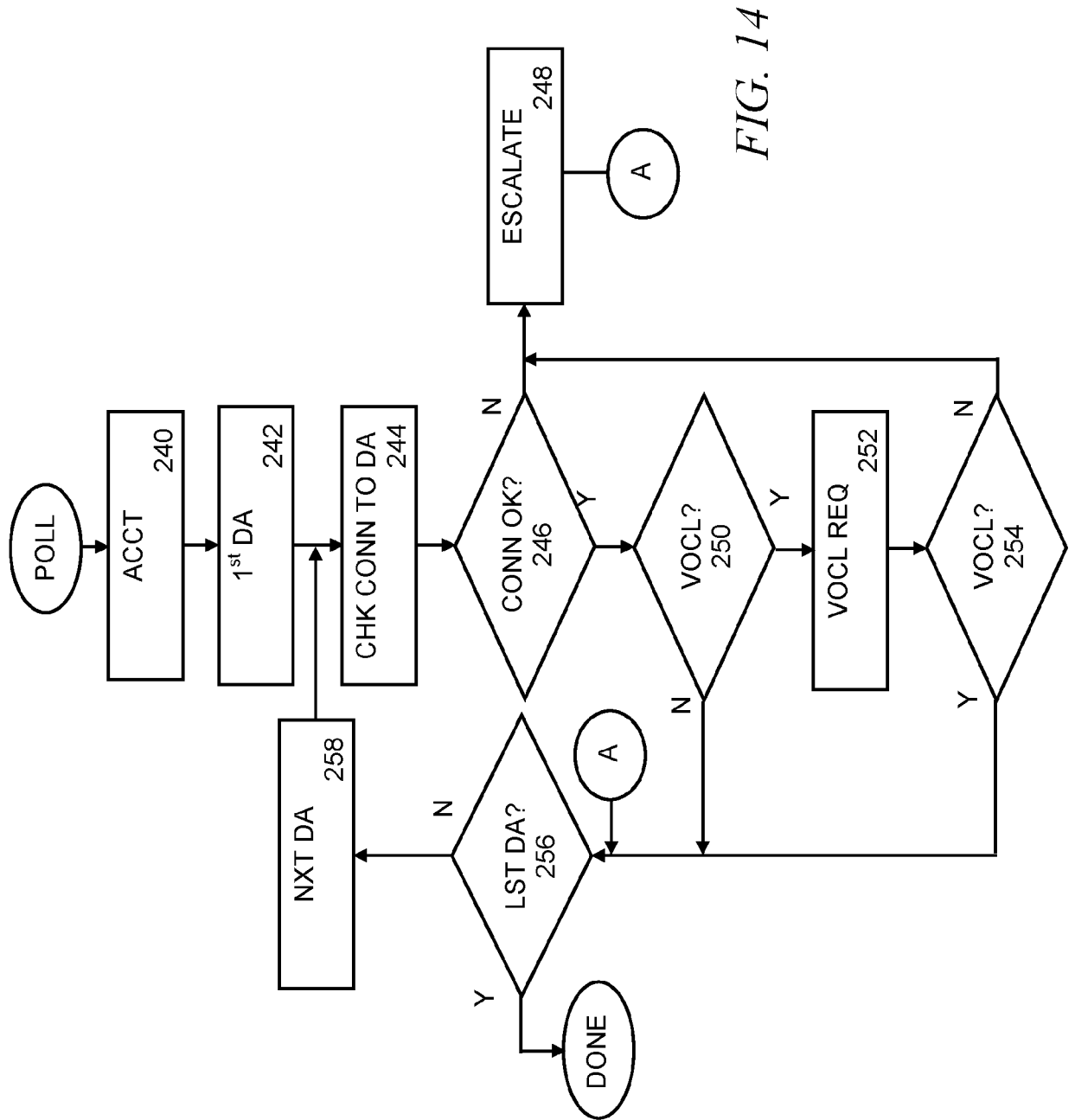

FIG. 14

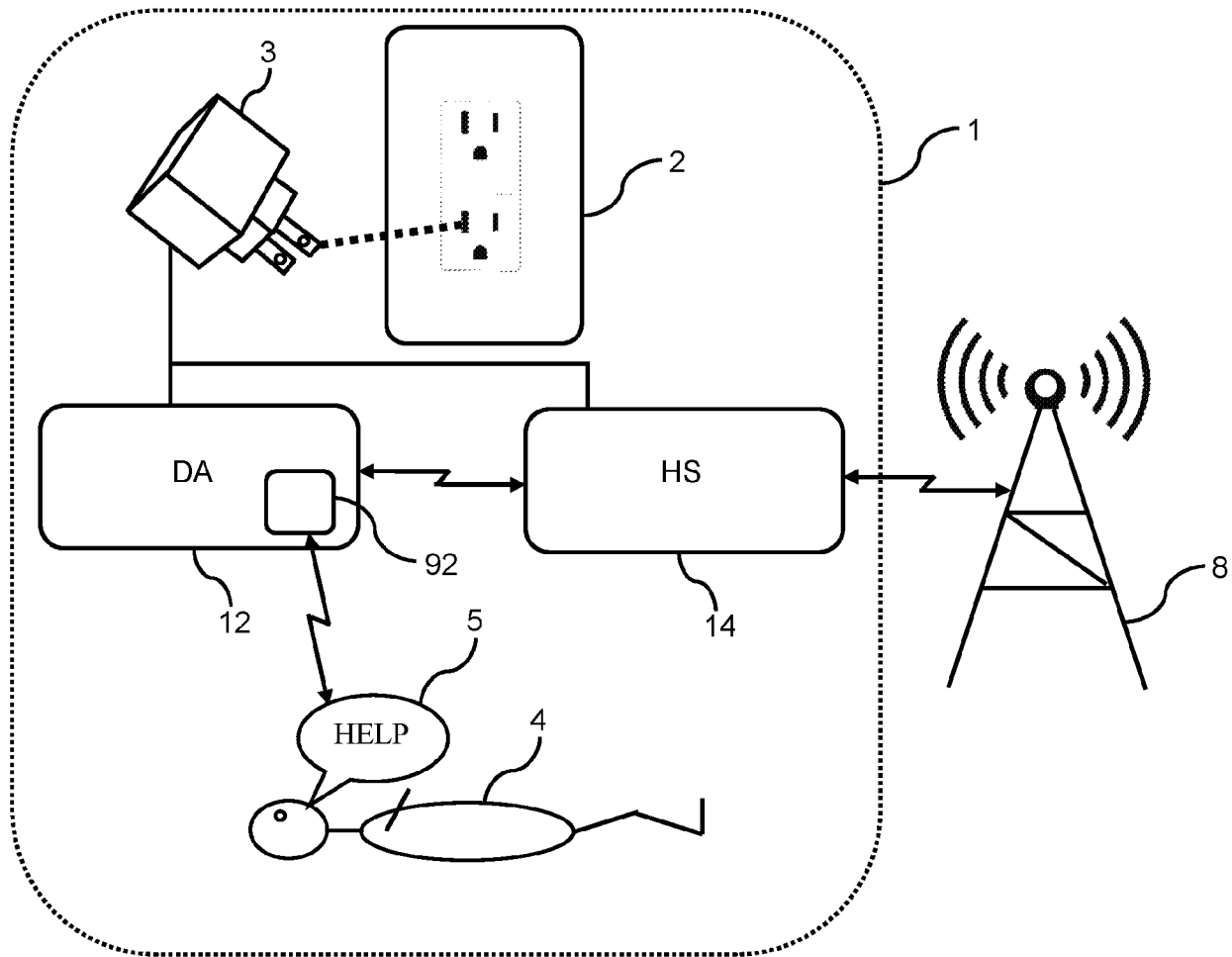

FIG. 6