

(19) World Intellectual Property Organization
International Bureau



(43) International Publication Date
22 February 2001 (22.02.2001)

PCT

(10) International Publication Number
WO 01/13563 A2

- (51) International Patent Classification⁷: H04L
- (21) International Application Number: PCT/US00/22099
- (22) International Filing Date: 11 August 2000 (11.08.2000)
- (25) Filing Language: English
- (26) Publication Language: English
- (30) Priority Data:
60/148,861 13 August 1999 (13.08.1999) US
- (71) Applicant: NETCENTIVES, INC. [US/US]; 475 Bran-
nan Street, San Francisco, CA 94107 (US).
- (72) Inventor: SCOGNAMILLO, Frank; 1630 South Canyon
Drive, Phoenix, AZ 85048 (US).

- (81) Designated States (*national*): AE, AG, AL, AM, AT, AU, AZ, BA, BB, BG, BR, BY, BZ, CA, CH, CN, CR, CU, CZ, DE, DK, DM, DZ, EE, ES, FI, GB, GD, GE, GH, GM, HR, HU, ID, IL, IN, IS, JP, KE, KG, KP, KR, KZ, LC, LK, LR, LS, LT, LU, LV, MA, MD, MG, MK, MN, MW, MX, MZ, NO, NZ, PL, PT, RO, RU, SD, SE, SG, SI, SK, SL, TJ, TM, TR, TT, TZ, UA, UG, UZ, VN, YU, ZA, ZW.
- (84) Designated States (*regional*): ARIPO patent (GH, GM, KE, LS, MW, MZ, SD, SL, SZ, TZ, UG, ZW), Eurasian patent (AM, AZ, BY, KG, KZ, MD, RU, TJ, TM), European patent (AT, BE, CH, CY, DE, DK, ES, FI, FR, GB, GR, IE, IT, LU, MC, NL, PT, SE), OAPI patent (BF, BJ, CF, CG, CI, CM, GA, GN, GW, ML, MR, NE, SN, TD, TG).

Published:

— Without international search report and to be republished upon receipt of that report.

- (74) Agents: TAGLIAFERRI, Daniel, D. et al.; Townsend and Townsend and Crew LLP, Two Embarcadero Center, Eighth Floor, San Francisco, CA 94111-3834 (US).

For two-letter codes and other abbreviations, refer to the "Guidance Notes on Codes and Abbreviations" appearing at the beginning of each regular issue of the PCT Gazette.

(54) Title: TRANSACTION BASED AWARD PROGRAM

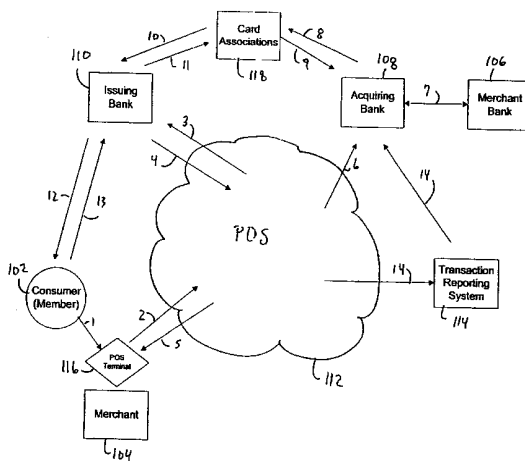

(57) Abstract: A transaction based award program method and apparatus that includes a list of members and merchants participating in the program. A method is provided for operating the transaction based award program wherein participating members earn awards from participating merchants based on transactions recorded in electronic transaction records. The awards being provided in a common currency and wherein the participating merchants are not limited to conducting business in the same or substantially similar industries. The method includes the steps of maintaining a member database and a merchant database that include identification information about the participating members and the participating merchants, respectively, obtaining at least one electronic transaction record that describes a transaction between at least one participating member and at least one participating merchant, determining that the transaction is a qualified transaction, calculating an award value for the qualified transaction, wherein the award value is based on a common currency that is common to all the participating merchants, and accumulating the award value into an award account that is associated with the at least one participating member.

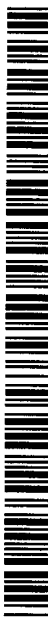

WO 01/13563 A2

TRANSACTION BASED AWARD PROGRAM

CROSS REFERENCE TO RELATED APPLICATIONS

This application claims priority from a co-pending U.S. Provisional Patent
5 Application, filed August 13, 1999 Application No. 60/148,861 in the name of Frank
Scognamillo for, "TRANSACTION BASED AWARD PROGRAM", the contents of
which are incorporated herein in their entirety for all purposes.

FIELD OF THE INVENTION

10 The present invention relates generally to consumer award programs, and
more particularly, to an award program based on consumer transactions utilizing an
electronic payment record (i.e. credit cards, debit cards, smart cards, check truncation
transactions, and other electronic payment records).

BACKGROUND OF THE INVENTION

15 There are numerous loyalty and frequent purchase programs in place
today. Virtually every merchant or entity who offers goods or services to consumers
spends considerable money offering special reward programs or incentives intended to
encourage consumers to shop more frequently. For example, restaurants, retail stores,
20 and travel and entertainment providers offer programs that entitle the consumer to a
tangible award after making a set number of purchases. The award is based on a
merchant derived formula relating to the merchant's business model and profit margins.
Some programs are electronically based, many others are manual and require the
consumer to carry merchant specific cards that need to be presented, swiped, punched or
25 otherwise used to obtain the award. Unfortunately, many consumers do not carry these
cards and are therefore unable to participate in the associated reward program.

Each of these frequent usage programs is a stand alone program relating
only to a single or related group of merchants. Thus, a typical consumer will have a
number of separate reward cards or accounts for each merchant. The consumer must
30 remember to use the cards or related identification numbers when making a purchase or a
payment to a particular merchant in order to accumulate points related to, for example,
the amount of each purchase or miles flown with a particular merchant or company.

One disadvantage of this type of frequent purchase program is that the

accumulated points or miles may only be redeemed with the particular merchant or airline. Thus, while the award redemption at a particular merchant may be of value to a consumer, it may take a considerable amount of time and a considerable number of separate purchases in order to qualify for an award at each merchant.

5 An example of one award program is a registered credit card program involving a group of participating restaurants, in which consumers enroll to participate. Each transaction or payment by the consumer using the registered credit card at any of the participating restaurants is handled by an organization which is part of the credit card bank transaction process. This organization matches the consumer payment to the
10 consumer transaction with a participating restaurant and automatically credits the consumer with a refund of the transaction value, such as 10%, 20%, etc. However, this award program is limited only to the group of participating restaurants and to the use of registered credit cards.

A major issue in today's consumer market is the conflict between
15 consumers concerns about privacy with respect to the use of their personal data, including their purchasing habits, versus the increasing need for merchants to obtain current and detailed consumer purchase information for competitive marketing purposes. As a result, merchants have attempted to use a number of information management techniques to retrieve and organize this data. However, as sophisticated as these information
20 management methods are, such methods do not accurately predict the future buying behavior of consumers. Additionally, the sources of consumer information currently being used are disjointed. For example, one typical source is a questionnaire voluntarily filed out by a consumer when buying a product. The questionnaire provides broad categories in an attempt to determine past purchases, income level, hobbies and interests
25 of consumers. Unfortunately, only a percentage of consumers actually complete the questionnaire, thereby limiting the effectiveness of the data.

Consumers on the other hand typically wish to limit information about themselves, their lifestyle, leisure activities, and their product preferences. More importantly, consumers are becoming increasingly concerned with a common practice,
30 used by credit card companies and other entities, of selling consumer information without the approval or knowledge of the consumers.

Thus, it would be desirable to provide an award program which addresses the issue of consumer privacy while still providing a broad, accurate database for use by merchants in obtaining information concerning consumers' activities, actual purchases,

etc. It would also be desirable to provide an award program that minimizes the qualifying activities required from participants (i.e. presenting special merchant cards), while still allowing consumers to participate in award programs offered by a wide range of merchants doing business in diverse industries.

5

SUMMARY OF THE INVENTION

The present invention includes a method and apparatus for providing a transaction based award system that brings together a large “pool” of consumers who wish to transact business with a large pool of merchants in order to earn common
10 currency awards. One embodiment included in the present invention is an award system that receives transaction records that include potentially qualifying transactions between participating consumers and participating merchants. The merchants may be in diverse industries offering different types of goods and services. The award system processes the potentially qualifying transactions to determine actually qualifying transactions that result
15 in an awards to the participating consumers. The determination is done based on certain conditions, for example, whether or not the merchants and consumers are enrolled in the program. The award system operates automatically and independent of any electronic transaction processing for credit cards, checks, electronic funds transfer, etc. For every actual qualified transaction, enrolled consumers automatically receive benefits from
20 enrolled merchants in a common currency. As a result, enrolled consumers need only have a single enrollment to qualify for awards from all types of merchants instead of having individual memberships in each merchant’s specific award program.

The included method and apparatus enable participating consumers to redeem their accumulated currency for a variety of values (i.e. merchandise, gift
25 certificates, airline miles or cash awards). For example, a consumer who may have acquired award currency based on shopping at gas stations, supermarkets or dry cleaners, can redeem that award currency for goods or services at a participating clothing retailer.

In one embodiment of the invention, a method is provided for operating a transaction based award program wherein participating members earn awards from
30 participating merchants based on transactions recorded in electronic transaction records. The awards being provided in a common currency and wherein the participating merchants are not limited to conducting business in the same or substantially similar industries. The method includes the steps of maintaining a member database and a merchant database that include identification information about the participating members

and the participating merchants, respectively, obtaining at least one electronic transaction record that describes a transaction between at least one participating member and at least one participating merchant, determining that the transaction is a qualified transaction, calculating an award value for the qualified transaction, wherein the award value is based
5 on a common currency that is common to all the participating merchants, and accumulating the award value into an award account that is associated with the at least one participating member.

In another embodiment of the present invention, a transaction apparatus is provided that is operable to provide a transaction based award program wherein
10 participating members earn awards from participating merchants based on transactions recorded in electronic transaction records. The awards being provided in a common currency and wherein the participating merchants are not limited to conducting business in the same or substantially similar industries. The apparatus includes a member database that includes identification information about the participating members. The apparatus
15 also includes a merchant database that includes identification information about the participating merchants. The apparatus also includes a receiver having logic to obtain a plurality of electronic transaction records, wherein the electronic transaction records include at least one electronic transaction record that provides transaction information about at least one transaction between at least one participating member and at least one
20 participating merchant. Additionally, the apparatus includes a processor that includes: logic to determine if the at least one transaction is a qualified transaction; logic to calculate an award value for the qualified transaction, wherein the award value is based on a common currency that is common to all the participating merchants; and logic to accumulate the award value into an award account that is associated with the at least one
25 participating member.

The various features, advantages and other uses of the present invention will become more apparent by referring to the following detailed description and accompanying drawings.

30 BRIEF DESCRIPTION OF THE DRAWINGS

FIG. 1 shows a prior art credit card transaction system for processing a credit card transaction between a consumer and a merchant;

FIG. 2 shows the credit card transaction system of FIG. 1 and includes a transaction based award system constructed in accordance with the present invention;

FIG. 3 shows a basic method of operating a transaction based award system in accordance with the present invention;

FIG. 4 shows a detailed block diagram of the transaction based award system shown in FIG. 2;

5 FIG. 5 shows a functional diagram of a merchant maintenance module included in the transaction based award system;

FIG. 6 shows a detailed block diagram of the merchant maintenance module;

10 FIG. 7 shows a functional diagram of a member maintenance module included in the transaction based award system;

FIG. 8 shows a detailed block diagram of the member maintenance module;

FIG. 9 shows a detailed block diagram of an administration module included in the transaction based award system;

15 FIG. 10 shows a detailed block diagram of a transaction processor included in the transaction based award system; and

FIG. 11 shows a method of operating a transaction based award system to provide awards to consumers based on electronic transaction information in accordance with the present invention.

20

DESCRIPTION OF THE SPECIFIC EMBODIMENTS

The present invention includes a transaction based award system. The following definitions are provided to clarify terminology used in the detailed description herein.

25 Definitions

“Members” refers to consumers, both individually or as part of an interest group that have agreed to participate in the program.

“Merchants” refers to business enterprises that sell goods or services to consumers and that have agreed to participate in the program. Merchants also refers to businesses
30 or organizations that conduct non-monetary transactions with consumers but still agree to participate in the program to award Members for such transactions.

“Network” refers to the combined pool of Members and Merchants interacting with one another.

“PQT” refers to potentially qualifying transactions that are Member transactions with participating Merchants without regard to whether the transaction qualifies for a discount or reward.

5 “AQT” refers to actually qualified transactions that comprise PQT’s that are determined to qualify for a discount or reward.

“Currency” refers to the reward value offered to Members. It may be points, miles, dollars or any other medium that the Member may exchange for value.

10 “Registered Card” means a consumer identification number (i.e. credit card, debit card or other type of consumer identification record) registered by a Member for reward recognition within the program.

“Electronic Transaction Record” refers to an electronic record that includes information about the Registered Card and an associated exchange of currency with a participating Merchant.

15 “Sponsor” refers to entities that enter into agreement with the program to facilitate the acquisition of new Merchants and/or Members.

“Electronic Card Transaction” includes any transaction which generates an electronic transaction record of the transaction, including transactions involving credit cards, debit cards, check truncation, supermarket saver cards, or direct electronic payments by Members to Merchants.

20 “Network Redemption Options” refer to a variety of values (i.e. merchandise, gift certificates, airline miles or cash awards) that are available in exchange for award currency earn by Members. Each Network may provide a different set of redemption options that are offered to Members in exchange for Currency.

25 Credit Card Transactions

Before describing the operation of the transaction based award system included in the present invention, a brief description of a typical credit card transaction including the transfer of the credit card information between various banking institutions will be provided.

30 FIG. 1 shows a diagram of a typical credit card transaction between a consumer 102 and a merchant 104 and includes participating banks and the interaction of data and payment flow.

The merchant 104 is typically associated with a merchant bank 106, with

whom the merchant 104 maintains various accounts. An acquiring bank 108 acquires and processes payment card transaction data on behalf of the merchant 104. The acquiring bank 108 sends or receives funds electronically with the merchant bank 106 as well as with card associations 118, such as Visa, MasterCard, American Express, Discover, 5 Diners, JCB, and/or companies processing private label cards. The card associations 118 interact with an issuing bank 110 that issued the credit card, debit card or the like to the consumer 102.

A Point of Sale (POS) processing institution 112 (clearinghouse) initially receives all of the electronic card transactions for merchants that are part of a particular 10 system or who have signed onto a particular system, with the POS coordinating and controlling records of payments between consumers and the merchants. The acquiring bank 108 has available to it, as part of its accumulated data records, each electronic card transaction, including the account of a particular consumer, the account of a particular merchant, and the amount of the transaction in the currency denomination of the 15 merchant's choosing. The acquiring bank receives a consolidated file from the POS clearinghouse 112 on a daily basis that includes all transactions performed at POS terminals (for example POS terminal 116) located at associated merchants. Simultaneously, transaction reporting system 114 receives a duplicate file of transaction information from the POS clearinghouse 112 and provides specialized reporting of 20 various information to the acquiring bank and/or merchants. For example, the transaction reporting system supplies risk management reporting to help the bank and the merchant avoid fraudulent transactions. Also, the merchants receive other reports to help reconcile their daily cash receipts. In another section herein, it will be shown how transaction information output from the transaction reporting system is usable by the transaction 25 based award system included in the present invention.

During a typical credit card purchase the following transactions take place. The dollar amounts shown are for illustrative purposes only.

1. The consumer 102 makes a purchase (for example, a \$100 purchase) at the merchant's 104 location by entering credit card information at the POS terminal 30 116.
2. A request for a \$100 authorization is sent to the POS 112.
3. A request for a \$100 authorization is sent from the POS 112 to the issuing bank 110.
4. An approval is provided by the issuing bank 110 to the POS 112.

5. An approval is provided by the POS 112 to the merchant 104.
6. The POS 112 transfers a \$100 payment record to the acquiring bank 108.
7. The acquiring bank 108 deducts its processing fees and transfers a \$97 credit to the merchant's designated account at the merchant bank 106.
- 5 8. The acquiring bank 108 advises the card association about the \$100 transaction.
9. The acquiring bank receives reimbursement of \$98 for the money already deposited to the merchant's bank account.
10. The card association sends an advice to the issuing bank for \$100 that the consumer has incurred a debt against their credit card account as well as \$2 from
10 the acquiring bank.
11. The issuing bank sends \$100 to the card association to reimburse it for the funds transferred to the acquiring bank.
12. The issuing bank bills the consumer.
13. The consumer sends a personal check to the issuing bank 110 for \$100 to cover
15 the cost of the purchase.
14. The transaction reporting system 114 is ancillary to the above process and is subscribed to by acquiring banks for risk management reporting and/or merchant reporting services. These services are an adjunct to the acquiring bank's business management practices.

20

Introduction

The following description describes a transaction based award system included in the present invention. For the purposes of clarity, the transaction based award system is described with reference to credit card transactions, however, it will be
25 understood by those with skill in the art that the herein described award system is suitable for use with any of the aforementioned payment mechanisms (i.e. debit cards, check truncations, etc.), or any other payment mechanism that utilizes an electronic transaction record. Thus, various methods of payment that trigger, becomes part of, or can be quantified in an electronic transaction record are suitable for use with the transaction
30 based award system. For example, the award system can provide awards to Members that make payments using credit cards, personal checks, electronic funds transfer, debit cards and even digital cash.

The award system is also suitable for use with other types of consumer transactions that utilize an electronic transaction record. For example, businesses,

consumer groups or other organizations may wish to provide awards to members for non-monetary transactions. For example, electronic transaction records can be used to record when a member completes specific earning activity, such as visiting a store ten times in one year, or referring customers to a particular merchant. Such electronic transaction records are also suitable for use with the award system included in the present invention, thereby allowing members to be awarded for non-monetary transactions.

The transaction based award system also allows business (such as supermarkets or department stores) to register their entire customer base with the award system. Thus, customers who shop at such businesses are eligible to receive award currency offered by the Network that can be exchanged for available redemption options selected by the Network.

Therefore, the award system included in the present invention uses electronic transaction records to provide a way for registered members to earn awards for all types of transaction activity (both monetary and non-monetary) associated with all types of merchants, consumer associations, or businesses.

Transaction Based Award System

FIG. 2 shows the diagram of the typical credit card transaction of FIG. 1 and includes a transaction based award system 200 ("award system") constructed in accordance with the present invention. The award system 200 couples to the transaction reporting system 114 as shown at path 202. Assuming that the merchant 104 is a participating Merchant, electronic transaction records relating to the Merchant that are processed by the POS 112 are transmitted to the transaction reporting system 114, whereinafter, the transaction reporting system transmits the Merchant's electronic transaction records to the award system 200 via path 202. In another embodiment, the Merchant sends electronic transaction records directly to the award system 200 via path 204. For example, the Merchant may be a high volume Merchant or may want to process electronic transaction records not associated with a monetary transaction.

The award system 200 operates to process the received electronic transaction information to determine awards for registered Members. Awards that are accumulated by each registered Member may be redeemed by the Members via a connection to the award system, for example, as shown by path 206. The Member may also use the connection path 206 to check award balances or perform other administrative functions. The connections to the award system may be direct connections or connections

via a data network, such as an Internet connection or private data network connection.

Basic Operation

FIG. 3 shows a flow diagram 300 of the basic operation of a transaction based award system included in the present invention. One function of the award system is to provide awards to Members based on electronic transaction information. The award system operates to register Members as shown at block 302 and to register participating Merchants as shown at block 304. Next, the award system receives electronic transaction information regarding transactions involving participating Merchants, as shown at block 306. For example, a participating Merchant may sell goods or services to consumers, where the consumers use a payment card to make the purchase. A Merchant identifier, purchase information and the payment card information form part of an electronic transaction record that is transmitted to the award system. At block 308, the award system determines, based on the received transaction records whether any registered Member will receive an award for any particular transaction. For example, the award system analyzes the transaction records to determine if any transactions involve both registered Merchants and Members. If so, based on certain conditions stipulated by the Merchant, an award for the transaction is computed. At block 310 a database containing Member awards is updated to reflect the new award earned by the Member for the transaction.

Additionally, the award system provides a redemption process, as shown at block 312, to allow Members to redeem awards or to perform administrative functions, such as to check account status. The awards may be redeemed for merchandise, gift certificates, airline miles or in some cases, cash. There is no requirement that the awarding and redeeming Merchant be the same or that they provide goods or services in the same business or industry.

Description of One Embodiment

FIG. 4 shows a detailed diagram of one embodiment of the award system 200. The award system 200 includes a transaction processor 402, an transaction database 404, a member maintenance module 406, a merchant maintenance module 408, an administration module 410 and a redemption module 412. The member maintenance module includes a member database 414 and the merchant maintenance module includes a merchant database 416. Although not shown in FIG. 4, other elements of the award

system 200 may have internal memory or have access to external memory to store parameters or other data to facilitate operation of the award system.

The transaction processor 402 includes a transaction reporting interface 418 that has logic to receive transaction records, via path 424, from a transaction reporting system, such as the transaction reporting system 114. The transaction reporting interface 418 may also receive transaction information directly from Merchants via path 424. For example, Merchants or other businesses may report transaction records directly to the transaction reporting interface 414 via path 424.

The transaction processor 402 couples to the merchant module 408, via bus 430, to retrieve information pertaining to merchants and merchant offerings from the merchant database 416. The transaction processor 402 also couples to the member module 406, via bus 430, to retrieve information pertaining to Members from the member database 414, for example, to determine if a Member's enrollment date is before a particular transaction date.

To perform the award determination, the transaction processor 402 receives the electronic transaction data from the interface 418. The electronic transaction data includes a valid Merchant identification number, a valid consumer identification number (i.e. "Registered Card"), a dollar amount, and a transaction date, all associated with a particular transaction. The transaction processor uses this information to access the merchant database 416 to determine if the merchant is currently a participating Merchant and to determine what award offers are available from the Merchant. The transaction processor also accesses the Member database 414 to determine if the consumer identification number is registered with the system. The transaction processor then determines if the transaction qualifies for an award based on other parameters associated with the merchant account. For example, the other parameters may be used to determine if an award is currently being offered for the particular good or service purchased, or to determine if a bonus award is being offered. If the transaction qualifies for an award, the transaction processor performs all mathematical computations necessary to compute the award value. The transaction information is stored in the transaction database 404 and the newly computed award is accumulated into the Members currency account at the Member database 414.

The Member maintenance module 406 and the Merchant maintenance module 408 can be accessed, via paths 420 and 422 respectively, to allow newly enrolled Members or new participating Merchants to be added to their respective databases. The

paths 420 also provides access to Members to obtain account status information. The path 422 also provides access to Merchants to allow updating of reward program parameters. For example, a Merchant may change the expiration date of a particular reward program. Members and Merchants may register with the award system by
5 interacting with the Member and Merchant maintenance modules, respectively, or by registering with a third party service that provides the registration information to the Member and Merchant maintenance modules via paths 420 and 422.

The administration module 410 couples to the merchant database 408 and the member database 406 via bus 434, and couples to the transaction database 404 and the
10 redemption module 412 via bus 432. The administration module is the control center and includes logic to allow all the databases to be maintained.

The redemption module 412 is activated only when Members contact the award system to totally or partially redeem their accumulated currency for the many options that are available. For example, Members can contact the redemption module
15 412 via path 424 to redeem accumulated currency for the Network redemption options that are available. During redemption, the redemption module 412 accesses the Members currency account located at the Member database 414 and provides an award based on a Member selection. For example, the Member may select that the award be provided as a gift certificate valid at a selected Merchant. The redemption module 412
20 uses various account security measures to protect Member accounts from losses due to fraud or other illegal means.

The redemption module includes a redemption processor which can be programmed to automatically sweep miles to selected airlines (if the Member has selected that redemption option). In another Member selection, detailed codes to identify
25 merchandise or gift certificates selected by the Member are added to a file that is sent to an outside fulfillment house that actually sends the selected item to the Member. The redemption processor then deducts the amount of currency used for the redemption from the Member's available currency balance.

30 Merchant Enrollment

FIG. 5 shows a functional diagram of the merchant maintenance module 408 included in the present invention. The merchant module 408 is used to register new merchants and update and maintain the records of previously registered merchants. After obtaining written permission to obtain access to electronic transaction data from the

merchant and any applicable acquiring institutions, the merchant module obtains a merchant identifier to associate payment transactions to a particular merchant. The merchant module 408 also obtains merchant bank account information pertaining to accounts at the merchant bank. In addition, the merchant module 408 can store various demographic information (i.e. address, contact name, contact phone number) to facilitate and support merchant relationship management.

During merchant registration, the merchant provides all the information necessary to mathematically describe award programs the merchant has selected for consumers. For example, a standard award program as shown at 502, or a special award program as shown at 504. Typically, the merchant's standard award program 502 is based on a industry segment in which the merchant is involved (gas, catalogue, restaurant, retail). For example, a gas station merchant may select a standard program award of one mile or point per two dollars of gas or service purchased, whereas a retailing merchant could select a standard award of three miles or points per dollar spent and a restaurant merchant could choose a standard award of ten miles per dollar spent.

It will be understood that the award referenced in this document is referred to as Currency as described in the Definition Section of this document. In fact, the award system can define any common currency or value indicator for use by all participating merchants in a given Network. It is also possible that multiple Networks could exist, and therefore, different Networks could choose to use a different common currency value.

Merchants may also select from different types of "special" award programs or participation options to apply to member purchases in addition to the "standard" program in effect for that merchant. Applicable date ranges may be specified on any of the special programs. Merchant administrative databases contained in the Merchant database 416 warehouse all information relating to a merchant's selected "standard" and "special" award programs. For example, special award programs may be established to:

1. Provide an additional award for the Member's purchase;
2. Provide an additional award for the Member's purchase if the total exceeds a specified minimum amount;
3. Provide an additional award for the Member's purchase on specified days of the week; or
4. Provide an additional award for the Member's purchase on specified days of the

week if the total exceeds a specified minimum amount.

Eligible Merchants can, on a periodic basic, assign Members to a “blackout” list that is stored in blackout database 506. Assignment to the blackout list will exclude a particular Member from that Merchant’s award benefits. For example, a
5 Member may be placed on the blackout list and excluded from the Merchant’s award programs for a set period of time, generally a one year period, or until the Member is removed from the blackout list by the Merchant.

A merchant sponsor database 508 keeps track of sponsors that have referred Merchants to the system. For example, a sponsor that refers a Merchant to the
10 system may be eligible to receive a referral service fee or additional fees for transactions involving that particular Merchant.

FIG. 6 shows a detailed diagram of the merchant module 408. The merchant module 408 includes a merchant processor 602 coupled to a variety individual databases comprises the merchant database 416. As described earlier, the database 416
15 supports merchant services as well as storing the mathematical parameters to compute award amounts and to bill the Merchant accordingly. The merchant processor 602 communicates with the transaction processor 402 via the bus 430 and communicates with merchants or merchant sponsors via bus 422.

20 Member Enrollment

FIG. 7 shows a functional diagram of the member maintenance module 406 included in the present invention. During enrollment of a new member, various member data is stored in a member database 414. Such data contains a number of separate inputs that allow several different member identity numbers to be captured, as
25 well as demographic information about the Member (i.e. title, full name, full address, start date, start anniversary, account status, age group, number or children, sex). The demographic information is voluntarily supplied by the Member and such information is not required for proper operation of the award system. If there is no demographic information, however, the member may not be a candidate to receive special mailings
30 from particular participating Merchants.

A member sponsor database 704 keeps track of sponsors that have referred Members to the system. For example, a sponsor that refers a Member to the system may be eligible to receive a referral service fee, or an additional fee for transactions involving that Member.

FIG. 8 shows a detailed diagram of the member module 406, and provides the individual components involved in supporting member customer service and award redemption. The member module includes a member processor 802 and various member databases 804. The member processor 802 communicates with the transaction processor 402 via the bus 430 and communicates with Members via bus 420.

As noted earlier, the transaction database 404 stores all AQTs. Each record contains the Member/consumer identification number and the Merchant identification number. Thus, by searching on either or both numbers various shopping parameters at a selected Merchant can be tracked. For example, it is possible to track how frequently a Member shops at a particular Merchant.

FIG. 9 shows a detailed diagram of the administration module 410. The administration module includes an administration processor 902 and various administrative databases 904. The administration module controls how and who can make changes to the member database (as part of customer service) and individual customer service access levels. The administration processor 902 also generates reports, as shown at 906, that can be used to provide transaction summaries or track system performance. The administration processor 902 communicates with the transaction database 404 and the redemption module via bus 432, and communicates with the member module 406 and the merchant module 408 via bus 434.

FIG. 10 shows a detailed diagram of the transaction processor 402. The transaction processor 402 operates to automatically process awards based on a received electronic transaction records. In one embodiment, a stream of electronic transaction records is received that is a duplicate or shadow file of the transaction records sent to a Merchant's acquiring bank. In another embodiment, electronic transaction records are received directly from participating Merchants.

Each electronic transaction between a Member and a Merchant is processed by the transaction processor to determine a match between information in the electronic payment record and the account or identification numbers registered by the Members and the Merchants in the program. It is assumed that prior permission has been obtained to receive such transaction data, and that the transaction processor obtains data only from Merchants who are participating in the program.

As shown in FIG. 11, a list of PQTs transmitted to the transaction processor is received by transaction receiver 1004 via path 420. The PQTs may be received from a transaction reporting system, such as system 114, or directly from a

Merchant, such as a high volume Merchant like a supermarket that transmits records of transactions by its customers. The PQTs are then stored in database 1006. The PQTs are prepared on a daily basis and transmitted to the transaction processor without regard as to whether a particular transaction results in an award or benefit to an enrolled Member. It is also possible to transmit and receive the PQTs at other time intervals, such as twice daily, weekly or bi-weekly, or any other interval selected by the Merchant.

The PQTs are processed by a validity processor 1008 to determine a list of PQTs that can be further processed by the transaction processor. The validity processor performs operations that check for valid promotion codes, duplicate transactions and date checks that verify that the Member enrollment date is prior to the transaction date. The PQTs that pass the validity checks performed by the validity processor 1108 are also checked against a "blackout list" stored in a blackout database 1010 that contains information pertaining to the most recent blackout information received from the Merchant maintenance module 408. This eliminates PQTs which have information that matches an entry in the blackout list, and thereby prevents any benefit accruing from those PQTs. For example, the blackout list may identify a Member as a previous customer and therefore not eligible for a duplicate award, or the blackout list may identify a Merchant that is not currently participating in a particular Network.

A qualifying transaction that passes both the validity and blackout tests will be identified as an actual qualified transaction, or AQT. All processing of the received transactions is performed under the control of a processor 1014, which is also coupled to the transaction database via bus 1012, and couples to the Member and Merchant modules via bus 430.

The processor 1014 stores the AQTs in the transaction database 404. AQTs between a Merchant and a Member which qualify for an award based on the Merchant's program's rules and applicable blackout rules are stored with various transaction data. For example, such data may include the Merchant and Member's identity number(s) and credit card, respectively, the Merchant's banking number, the amount of transaction, a currency code that specifies the currency, a transaction authorization number, a debit card indicator, debit card identity number and expiration date, method of transaction entry, bank card transaction reference number, merchant's terminal identification number, transaction date and time, transaction type, transaction amount applied to member's, merchant's and sponsor's accounts, whether a standard or special program identification number was employed, etc.

A separate merchant activity database, that is located in the Merchant module 408, is provided for each merchant and used to generate a report to each merchant once for a predetermined period, such as monthly. The various data can be stored in the merchant database 416 including the merchant's identity number, sponsor ID, period
5 ending date, type of period, whether day, week, month or year, the various payment, card, debit card, credit card, account, the number of transactions within and outside of the program, the number of AQT transactions and the total dollar amount of the AQT transactions. Also, the number and total amount of blacked out transactions may be stored.

10 The transaction history database 404 that contains information pertaining to transactions which have been used for redemptions, will be maintained for immediate access for a minimum period of time. Summary data at the merchant/month level, for example, can be stored for an additional period of time. All AQT data is stored in long-term storage to support any research regarding questions from Members and/or
15 Merchants about missing transactions or Merchant billing issues.

FIG. 11 shows a method 1100 of providing a transaction based award system in accordance with the present invention. It will be assumed that the information describing registered Members and Merchants is stored in member and merchant databases, respectively, and that such information can be retrieved in accordance with the
20 present invention as described in other sections of this document.

At block 1102, electronic transactions records are received. The electronic transaction records represent PQTs that may or may not result in awards to registered Members. The electronic transaction records are received periodically from participating Merchants. For example, electronic transaction records are received at the transaction
25 receiver 1004. At block 1104, the PQTs are stored in a memory for further processing. For example, the PQTs can be stored in the PQT database 1006.

At block 1106, a validity check is performed on the PQTs. The validity check determines whether the information in the PQTs represent valid transactions and access the Member and Merchant databases (414 and 416) as shown at block 1108. may
30 be needed to complete the check. For example, Member identification and a transaction date included the PQTs are compared to a Member database to verify that the Member's enrollment date is before the transaction date. For example, the validity processor 1008 accesses the Member database 414 via the processor 1014 to obtain the Member enrollment dates for comparison against the transaction dates in the PQTs. Other validity

checks may be performed as necessary to verify that the transaction information is current and accurate. In another example, PQTs that do not contain valid Member identifiers fail the validity check. PQTs that do not pass the validity checks are not used for the purposes of providing an award.

5 At block 1110, the PQTs that pass the validity checks are tested against a blackout database. The blackout database contains entries that may match information in the transaction records, and as a result, prevent any such transaction records from being used to provide an award. For example, the blackout database may contain a Member identifier that is associated with a particular Merchant, and may further be associated with
10 a particular Merchants offerings. This information may also appear in the transaction records, and if so, that transaction record would not be used to provide an award to the Member. Information may be placed in the blackout database for a variety of reasons. For example, a Member may have already received an award for a particular purchase. For example, the processor 1014 receives PQTs from the validity processor 1008 and
15 information from the blackout database 1010 and determines if any matches exist. If so, the Member associated with the particular transaction will not receive an award for the transaction.

 At block 1112, the PQTs that pass the validity and the blackout checks are considered to be AQTs and stored in the transaction database 404. For example, the
20 processor 1014 stored the information in the transaction database via path 1012.

 At block 1114, the AQTs are processed to determine Member awards. Participating Members in the AQTs are identified and information about Merchant offerings is used to compute award values to provide to the Members. For example, the Merchant may specify that transactions may be awarded 1 point for every dollar spent.
25 Thus, if the Member has purchased a \$100 item from the Merchant, the award would be calculated to be 100 points. To perform the award calculation it may be necessary to access Member and/or Merchant information as shown at block 1116. In one embodiment, the processor 1014 obtains information about Merchant offerings from the Merchant database 416 via bus 430. This information is used to calculate an award value
30 to be provided to the Member involved in the AQT.

 At block 1118, the Member account is updated to reflect the newly received award. For example, the processor 1014 accesses the Member account at the Member Module 406 to update the account with the award. Thus, the Member automatically receives the award without having to do more than becoming a registered

Member.

At the close of business of each day, for example, member awards will be calculated based on AQT activity in the established programs, i.e., “standard” or “special”, of the merchants involved in each AQT. Awards will be issued periodically, such as each month or each quarter, along with a statement, as cash rewards via check, as
5 travel miles to a designated airline program or as gift certificates for use with one or all of the participating merchants. The gift certificates are redeemed at a specified conversion rate based on the number of miles or points accumulated by a particular member, such as a \$25 gift certificate for each 2,500 miles or points. Each gift certificate is redeemable by
10 the member as payment for products in a merchant’s special program redemption catalog or, alternately, for any product or service at a participating merchant.

The award provided to Member is based on a common currency that is common to all participating Merchants. Thus, currency that is being redeemed by a particular Member can be redeemed for any of the Network redemption options offered,
15 and not just at Merchant which handled all or a majority of the transactions for a particular member, such as airplane tickets, etc. For example, points acquired by transactions by a Member at various Merchants within the program and exceeding a predetermined amount equivalent to a \$25 gift certificate, may be redeemable by the member for frequent flyer miles, etc.

20 The above description is illustrative and not restrictive. Many variations of the invention will become apparent to those of skill in the art upon review of this disclosure. The scope of the invention should, therefore, be determined not with reference to the above description, but instead should be determined with reference to the appended claims along with their full scope of equivalents.

WHAT IS CLAIMED IS:

- 1 1. A method of operating a transaction based award program wherein
2 participating members earn awards from participating merchants based on transactions
3 recorded in electronic transaction records, the awards being provided in a common
4 currency and wherein the participating merchants are not limited to conducting business
5 in the same or substantially similar industries, the method comprising steps of:
6 maintaining a member database and a merchant database that include
7 identification information about the participating members and the participating
8 merchants, respectively;
9 obtaining at least one electronic transaction record that describes a
10 transaction between at least one participating member and at least one participating
11 merchant;
12 determining that the transaction is a qualified transaction;
13 calculating an award value for the qualified transaction, wherein the award
14 value is based on a common currency that is common to all the participating merchants;
15 and
16 accumulating the award value into an award account that is associated with
17 the at least one participating member.
- 1 2. The method of claim 1, wherein the step of maintaining the
2 member database includes a step of allowing each of the participating members to register
3 at least one identification number into the member database.
- 1 3. The method of claim 2, wherein the step of determining comprises
2 a step of determining if the at least one transaction is a qualified transaction based on the
3 at least one identification number registered with each of the participating members.
- 1 4. Apparatus operable to provide a transaction based award program
2 wherein participating members earn awards from participating merchants based on
3 transactions recorded in electronic transaction records, the awards being provided in a
4 common currency and wherein the participating merchants are not limited to conducting
5 business in the same or substantially similar industries, the apparatus comprising:
6 a member database that include identification information about the
7 participating members;

8 a merchant database that includes identification information about the
9 participating merchants;
10 a receiver having logic to obtain a plurality of electronic transaction
11 records, wherein the electronic transaction records include at least one electronic
12 transaction record that provides transaction information about at least one transaction
13 between at least one participating member and at least one participating merchant; and
14 a processor that includes:
15 logic to determine if the at least one transaction is a qualified
16 transaction;
17 logic to calculate an award value for the qualified transaction,
18 wherein the award value is based on a common currency that is common to all the
19 participating merchants; and
20 logic to accumulate the award value into an award account that is
21 associated with the at least one participating member.

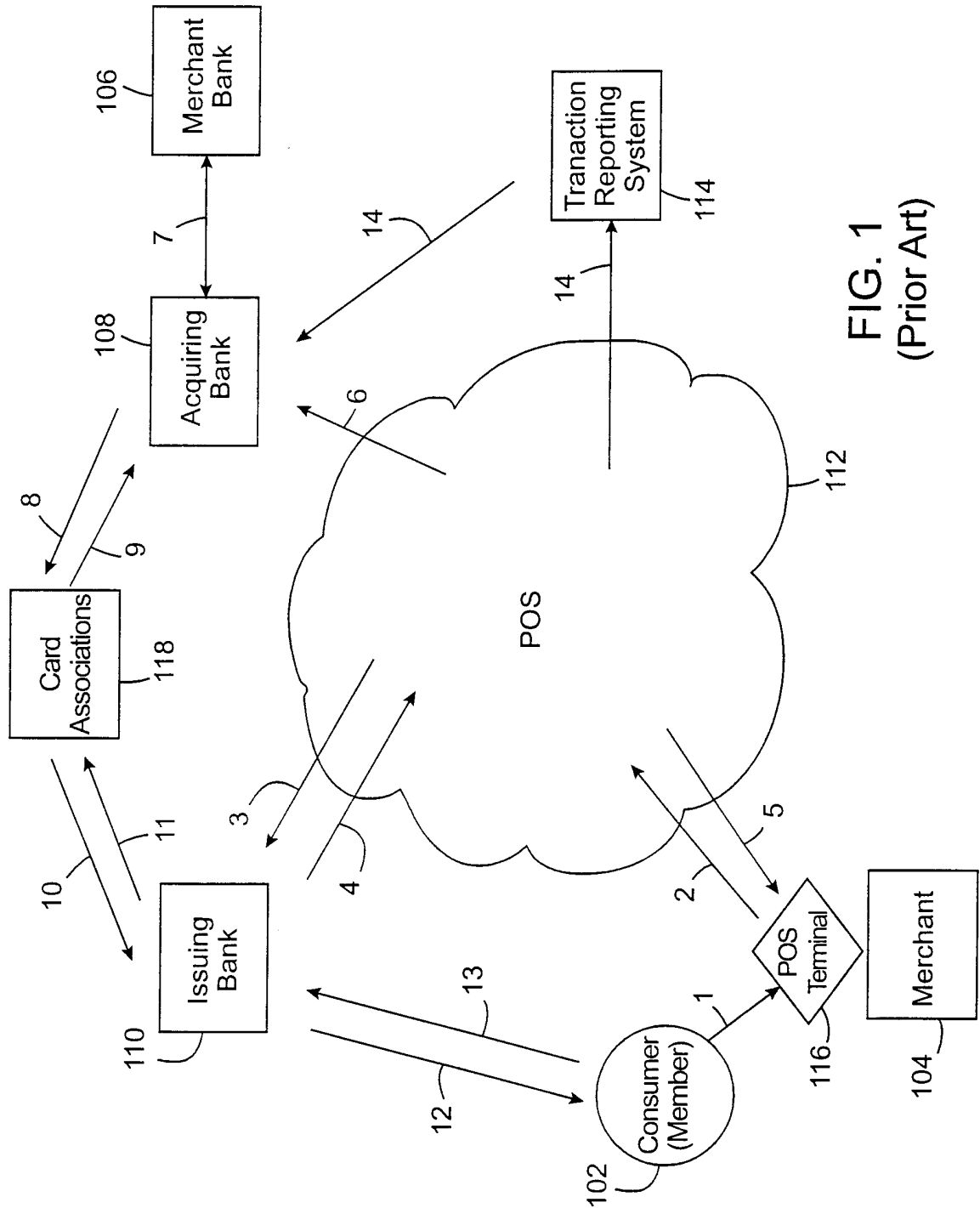
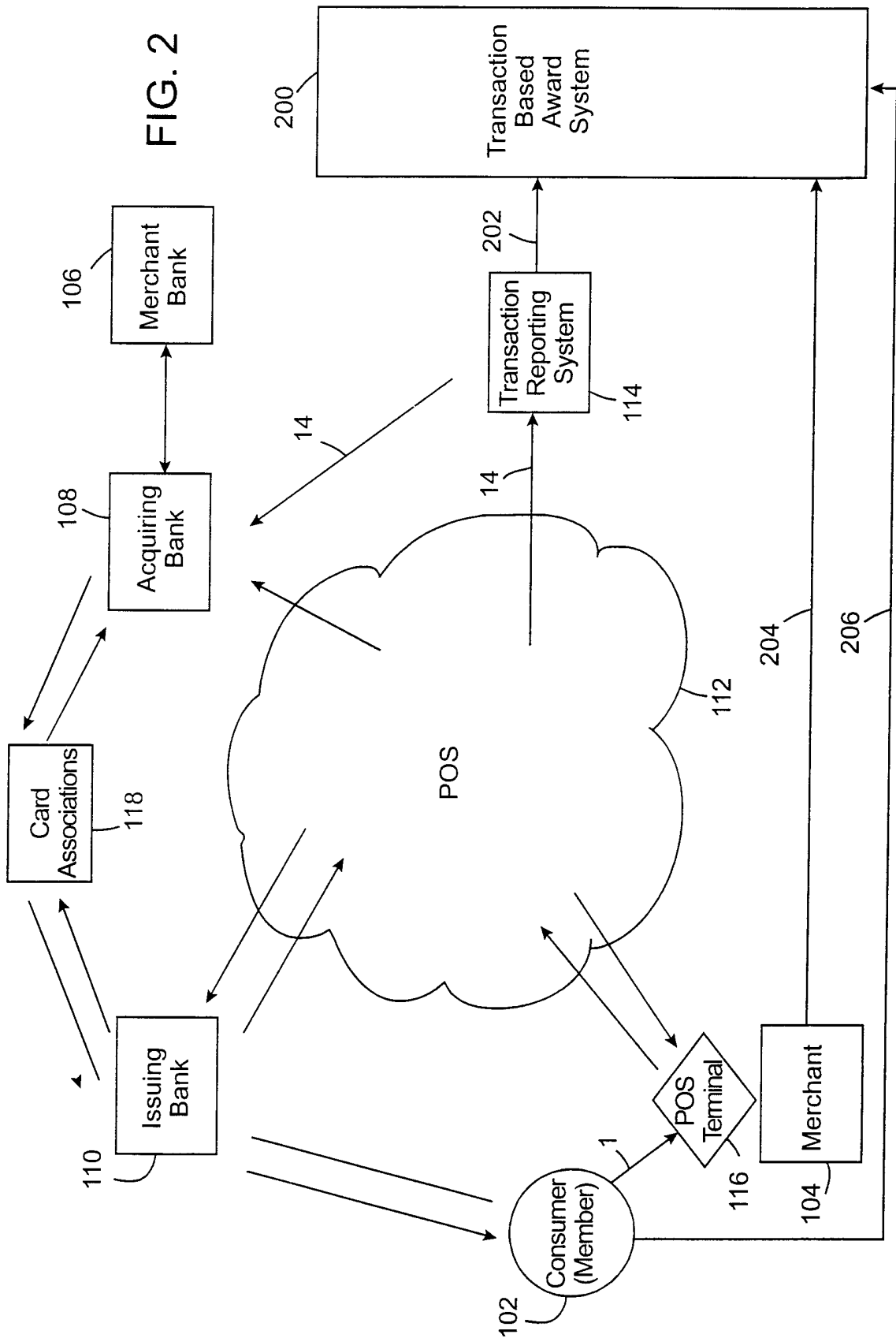

FIG. 1
(Prior Art)

FIG. 2



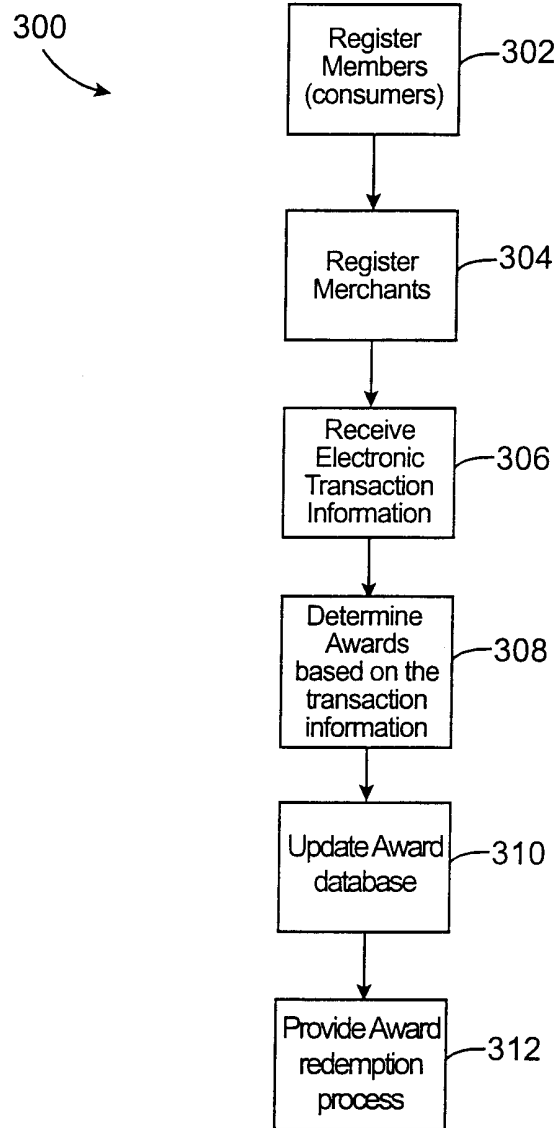

FIG. 3

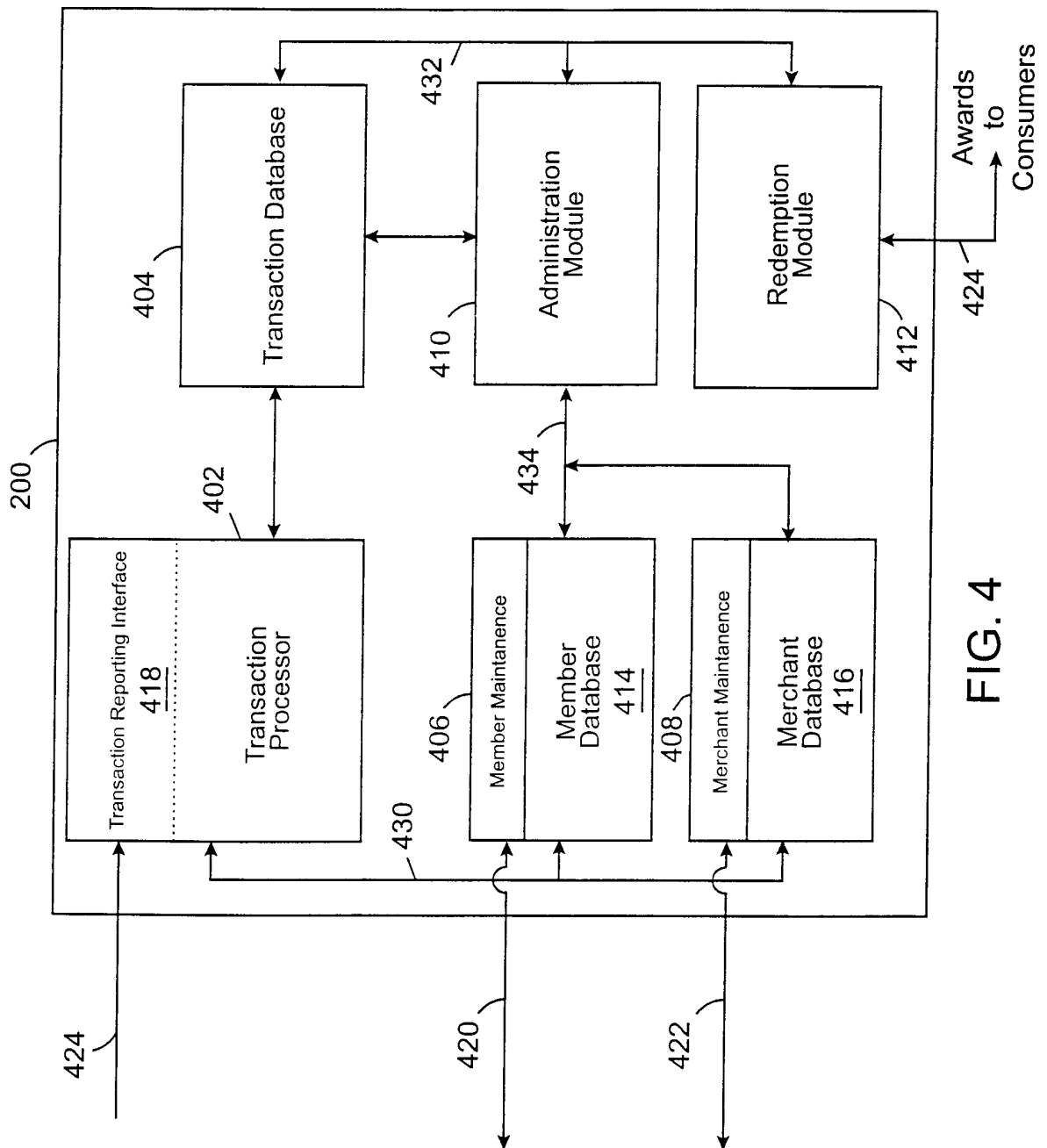

FIG. 4

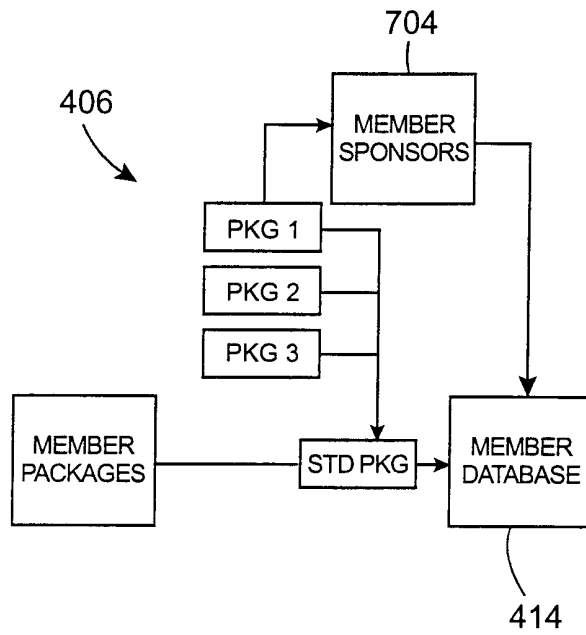

FIG. 7

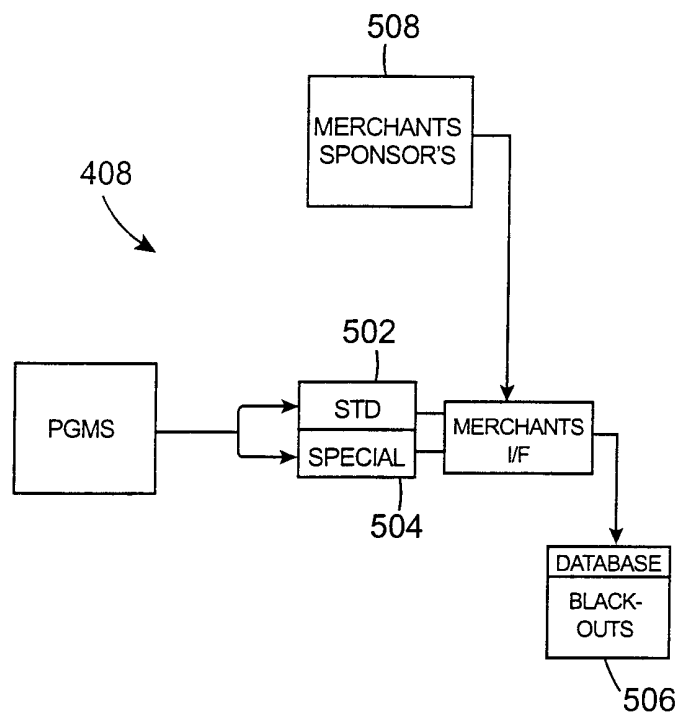

FIG. 5

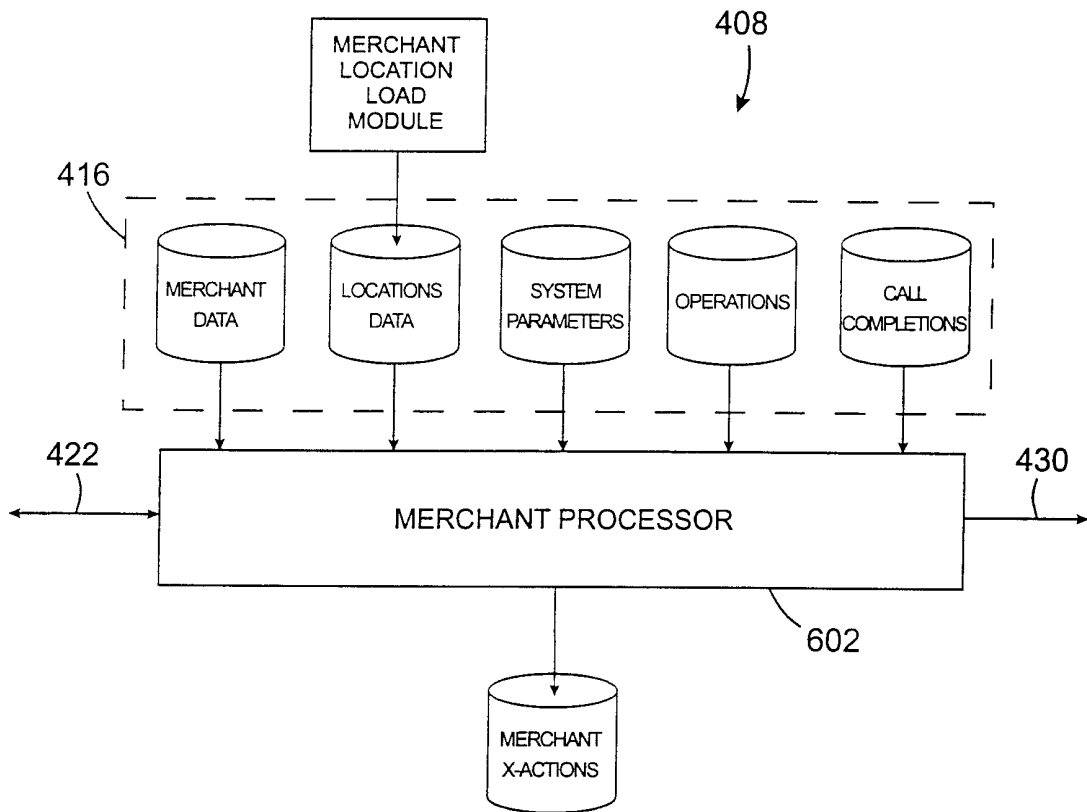

FIG. 6

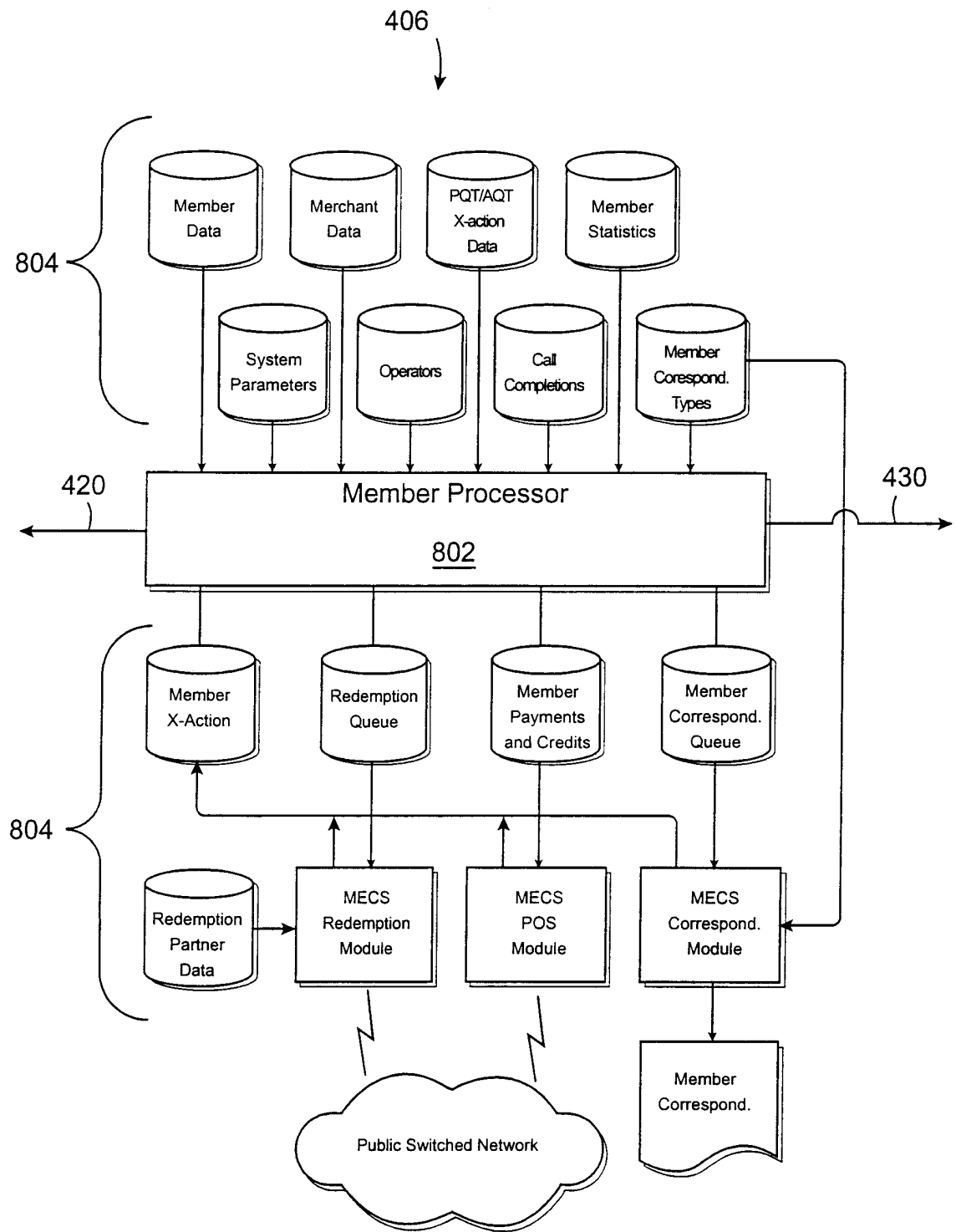

FIG. 8

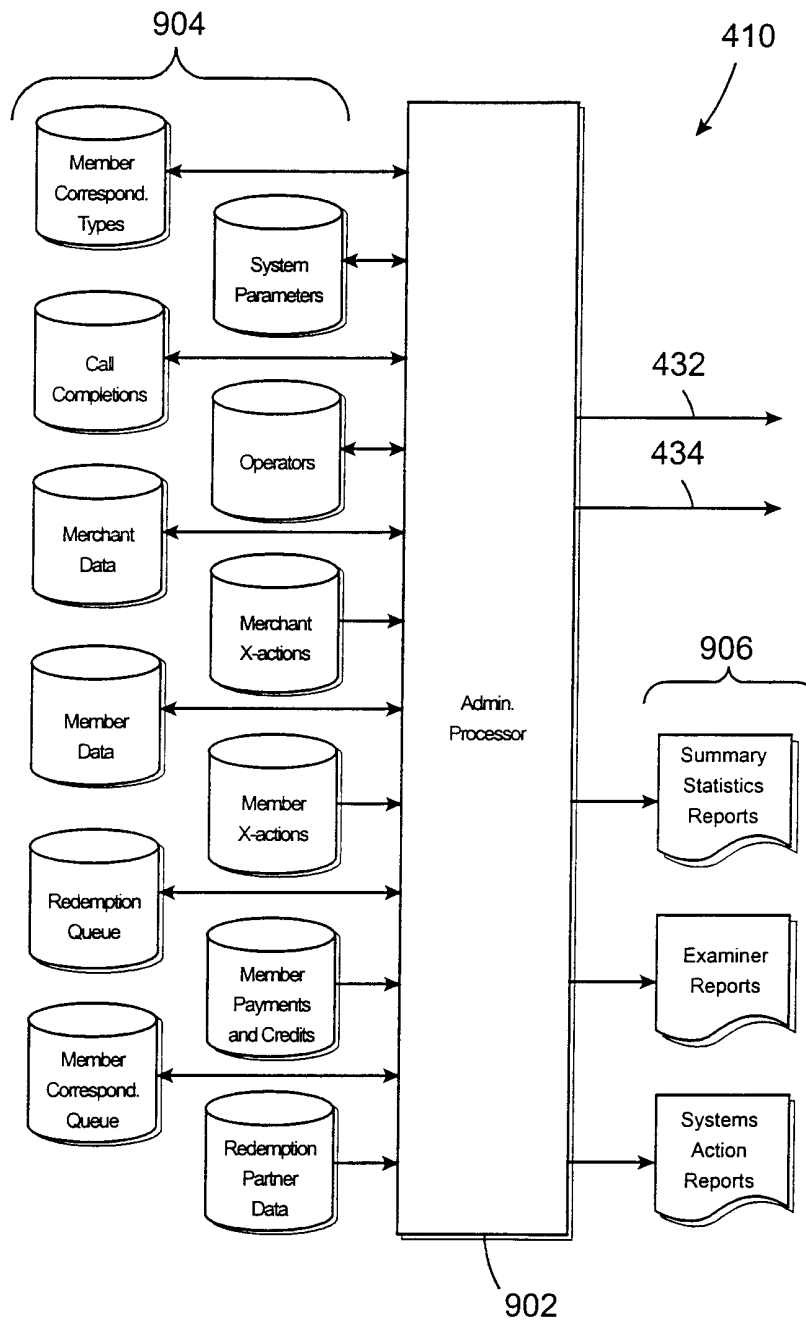

FIG. 9

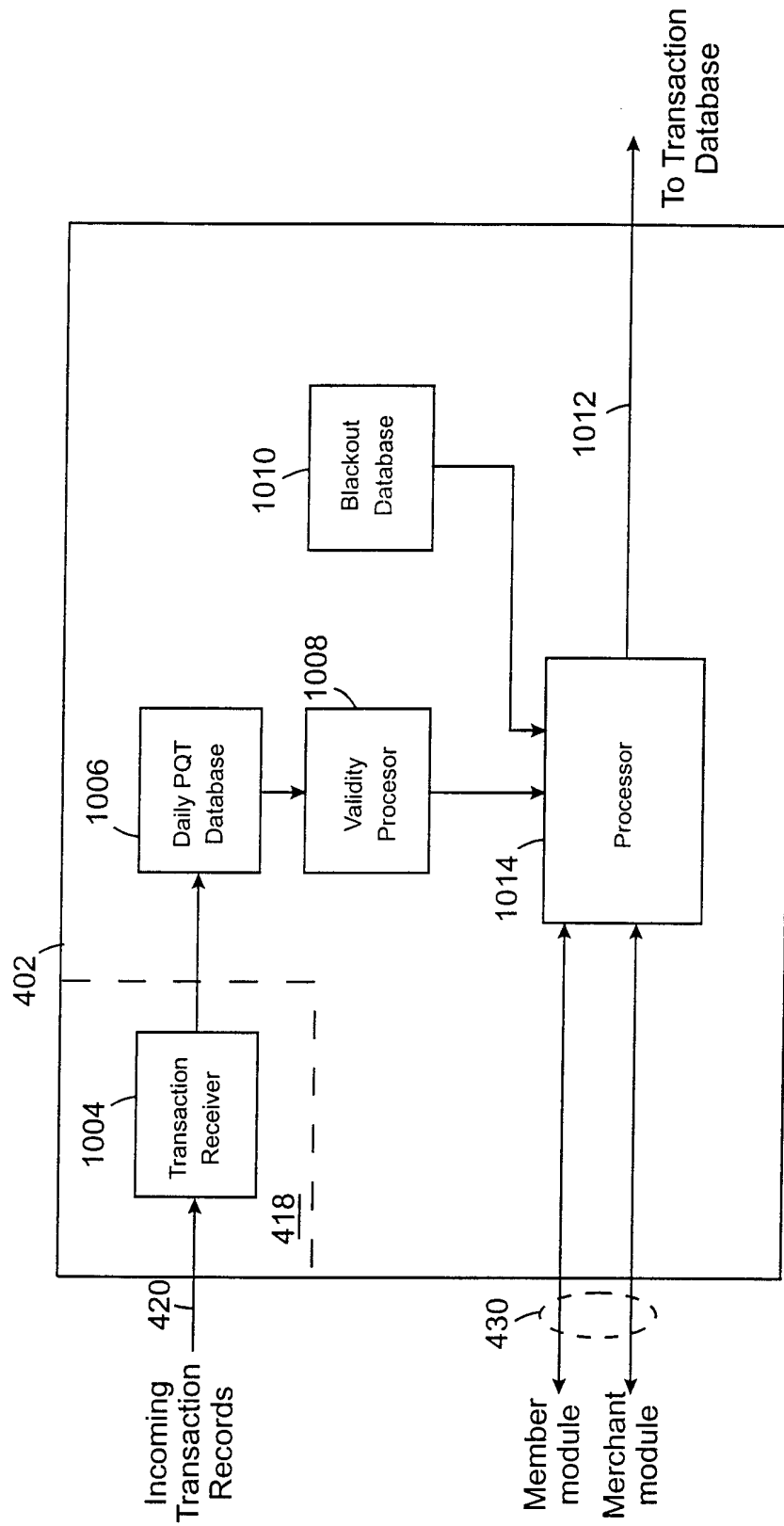

FIG. 10

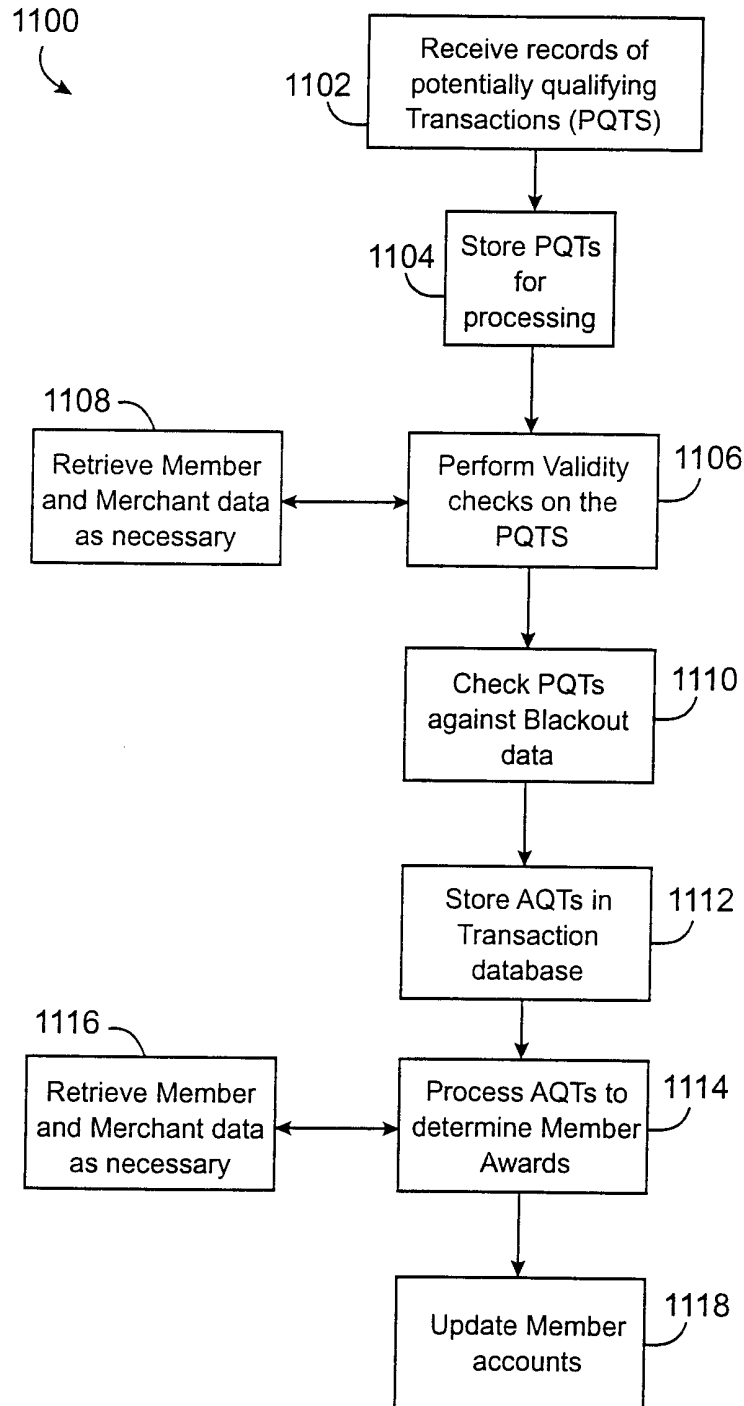

FIG. 11