

Published:

— *with international search report (Art. 21(3))*

FOOD PACKAGING CONTAINING AN INNER BAG

FIELD OF THE INVENTION

This invention relates to a packaging having a closure lid adapted to provide easy access to a product contained in a bag used as refill. More specifically, the invention relates to a food packaging adapted to make installation of a gusset bag inside an outer container easier.

BACKGROUND OF THE INVENTION

Gusset bags having a flexible side wall are well-known for containing a variety of products, especially flowable food products. Refillable food pouches are known, for instance from WO 2014/120258. But for air-sensitive contents, for example powdered milk or cereals, such kind of refillable pouch cannot be used.

Less sensitive food can also be supplied to a secondary market as a sealed gusset pouch or similar flexible bag. Conventional gusset bags for this purpose are provided with two opposite gussets. After removal of a top portion, the gussets can unfold from a partially open configuration to a fully open configuration. Such flexible bags (for example as disclosed in US 2011/0293208) are not well adapted for a pouring operation.

Rigid boxes are sometimes used to receive food content initially stored in flexible bags. The box can be repeatedly filled up with such kind of food. But practically, loss of food product from a gusset bag or similar bag often occurs when pouring the flowable food content into the box.

Besides, boxes are not particularly well adapted to store a gusset bag that is in an open state because the product can flow between the flexible bag and the inner face of the box. This typically happens when the whole packaging is turned upside down in a closed state of the box. And if the box is not correctly closed by a lid positioned at the top of the box or if the sealing performed by the lid is not efficient, the product may be quickly altered and loss of product may occur.

SUMMARY OF THE INVENTION

It is therefore an object of the present invention to provide a reclosable packaging which gives the content of the packaging good protection every time the lid is closed and which is efficiently refillable.

To this end, embodiments of the invention provide a packaging for a food product comprising:

- an outer container longitudinally extending about a central axis from a bottom to an upper face having an opening, the outer container having a peripheral upper rim delimiting the opening and a sidewall defining an interior volume of a determined height, the sidewall having two opposite inner faces, preferably planar,
- 5 - a closure system comprising a frame which is annular and fixed in a removable manner to the peripheral upper rim, and a lid hinged to the frame to allow movement of the lid between an open position and a closed position, in which the lid closes the opening of the container, the frame comprising an upper fitment part covering the upper rim;
- 10 - a gusset bag filled with food product and flexible, comprising a bottom, an upper end adapted to define an opening of the bag at the opposite from the bottom, an annular side wall provided with at least one gusset, preferably two opposite gussets, so that the bag is adapted to unfold from a partially open configuration to a fully open configuration, the sidewall of the outer container having a shape matching with the
- 15 annular side wall of the bag so as to prevent the bag to be eccentrically positioned inside the interior volume (predetermined position of the bag);
wherein the frame further comprises:
 - an insert part that extends in the interior volume and is radially spaced inwardly from the sidewall of the container, the insert part extending annularly entirely below the
 - 20 upper rim, and
 - a plurality of axial guiding extensions that belong to the insert part and configured to engage the bag through the opening of the bag to hold open the bag, the insert part having a notch defined between two of the axial guiding extensions, along one of said two opposite inner faces.

25 The bag may fully cover the inner face of the bottom and is close to the sidewall of the outer container so as to be either in contact with the two opposite inner faces, or substantially coaxial with the sidewall of the outer container with a small gap at its periphery. More generally it is understood that the bag is sized so that it cannot move significantly in a radial direction, i.e. not more than 5 or 6 mm, preferably less than 4

30 mm, when put in a storage position in the interior volume. Such small play typically represents less than 9 or 10 percents of the width or equivalent size of the bag as the smaller size of the container is typically greater than 60 mm, preferably greater than 80 mm.

35 With such arrangement of the closure system, the insert part can efficiently come into contact and push (radially outwards) portions of the bag side wall when

mounting the frame, thanks to the axial extensions, without interfering with unfolding of the bag, thanks to the notch. Since the bag side wall has substantially the same shape has the container near the bottom, there is no particular requirement for any centering of the bag. The top of the side wall of the bag has not to be particularly stretched or
5 folded more than the remainder of the side wall, which is of interest to prevent undesirable cracks in the bag material.

Additionally, the amount of plastic material to form the insert part is reduced as the notch typically defines a significant spacing between two axial extensions of a same side. This spacing may be superior to 30 mm near the free edges of the axial
10 extensions.

When the bag and the container have a polygonal shape, for example a rectangular shape, the guiding axial extensions may be provided each with an angled free edge in order to guide each upper edges of the bag in a peripheral area that is defined between the insert part and the top of the container. The bag is typically a
15 gusseted pre-made bag so that planar outer faces in the side wall are easy to obtain, such outer faces matching with the corresponding inner faces of the container. It should be understood that the wording "partially open configuration" may correspond to a free configuration where the opening is close to its size when the bag is configured in a fully open state. Thus the term "partially open" may simply be interpreted as "not fully
20 open" (typically not sufficiently open to have a regular gap between the top of the bag and the container).

In accordance with a particular feature, at least one of the two opposite inner faces is defined by a panel in contact with the upper fitment part and extends between two connections (preferably curved) that each define an angle, preferably of about 90°,
25 between two adjacent panels of the sidewall of the outer container.

In accordance with a particular feature, the sidewall of the outer container is defined by four panels interconnected at respective connections that extend each rectilinearly from the bottom to an angle of the peripheral upper rim, while the annular side wall of the bag is provided with four edges and has a predetermined periphery
30 sized and shaped so that each of the edges is at less than about 3 mm from one of the connections when the bag is stored in the interior volume and the upper rim is engaged into a groove of the fitment part. With such arrangement, positioning the bag is intuitive and easy and the upper edges of the bag can be positioned as a lining that covers the inner face of the container sidewall. Since the bag is hold in a fully open state by the
35 insert part (with the side wall of the bag thus longitudinally extending with a same small

radial spacing with respect to the container), risk of folding the bag is prevented when retrieving the food content.

In accordance with a particular feature, the notch extends between two planar portions of two axial extensions that are angled to have each a L-shape section when viewed in a plane perpendicular to the central axis. This configuration of the axial extensions is well adapted to prevent undesirable folding (of the bag) near the angles of the outer container, especially when the packaging has a polygonal shape with angles of about 90°.

In accordance with a particular feature, the insert part comprises four bridge portions each tapering toward the bottom with small deviation as compared to the central axis, said small deviation being preferably inferior or equal to 10°, each of the four bridge portions comprising:

- a notch extending between two axial guiding extensions; and
- an arched section that extends above the notch, between the two axial guiding extensions.

Optionnally, the insert part has four substantially planar outer faces, each arched section defining a midsection of said outer faces of the insert part

In accordance with a particular feature, the insert part is such that the following relation is satisfied:

$$H - H2 < 5 \text{ mm} < H1$$

where

H1 is the maximum height of the insert part,

H2 is a height of the flexible gusset bag in the fully open configuration, and

H is the determined height of the interior volume.

The height H2 is measured from a bottom part of the bag that is typically planar and in contact with the food content. The bag in the open state thus does not extend beyond the opening of the container and difference in height (as compared to the level of the container opening) can be lower than about 4 or 5 mm, preferably about 2 or 3 mm. With such small difference in height and as the insert part (by definition) is received inside the volume of the bag, with a sufficient height, the bag cannot vertically escape from the fully open configuration. More generally, having a small radial play (less than 2 or 3 mm) and a small axial play for the bag is advantageous to prevent significant deformation of the bag side wall (or any change in relative position between the bag and the insert part) when the whole packaging is turned upside down.

As the bag may be typically maintained without any fold or any collapse at the

top side (the side wall of the bag having a shape matching with the inner face of the rigid container), a partly or fully transparent box could also advantageously be used with a satisfactory display of information marked on the outer faces of the bag side wall.

5 In some variants, height of the bag may be lower, providing that the insert part is of greater height and/or the container is provided with one or more holding members or similar adjusting means for supporting the bag at a distance from the level of the bottom.

10 In preferred embodiments of the invention, use is furthermore made of at least one of the following arrangements:

- the bag and the container have each a polygonal shape, preferably a rectangular shape, the guiding axial extensions being provided each with an angled free edge in order to guide each upper edges of the bag in a peripheral upper area that is defined between the insert part and an upper part of the container, entirely above the angled
15 free edges in a fitted configuration of the fitment part (typically, each branch of the angled free edge is at least longer than 10 mm).

- the insert part comprises four axial guiding extensions that are entirely located inside a virtual cuboid, which has a rectangular first section inferior or equal to a rectangular
20 second section defined by the bottom of the bag (peripheral rectangular edge of the bottom of the bag).

- the insert part is provided with a first notch and a second notch at the opposite from the first notch, each of the first notch and the second notch being wider than high, the bag comprising two opposite gussets that unfold through the first notch and the second
notch, respectively.

25 - the packaging further comprises a measuring utensil having a cup and a handle, the measuring utensil being received by a retaining device in a storage position, in which the handle extends entirely above the insert part (with such storage position, typically a horizontal position, the measuring utensil can extend above the food content and does not interfere with the axial guiding extensions of the insert part).

30 - the first notch is at least partly adjacent to the cup in the storage position, the retaining device being connected to a first side of the frame, the second notch extending proximate to a second side of the frame which is parallel to the first side of the frame (accordingly, the cup is hold at a distance from the central axis of the container, while the handle to be caught by the user can intersect this central axis or
35 extend close to this central axis).

- the bag has an inner face provided with at least one initially energized annular elastic tape interfering with the two gussets, configured to deform radially outwards so that the bag automatically unfolds from an initial partially open configuration to another configuration that is close or identical to the fully open configuration (the bag, which is typically a refill initially provided with a closing band at the top, can reach the fully open configuration more easily with such biasing effect obtained after removal of the closing band).
- in the storage position, the cup is entirely offset with respect to a virtual median plane of the container which intersects the first notch and the second notch.
- the frame comprises an annular transition part between the insert part and the fitment part, the transition part tapering downwardly and defining a concave surface facing outwardly (the curvature of the annular transition part is suitable to push the upper edges radially outwards rather than crush downwardly such upper edges; besides, such transition part is of interest to provide an efficient guiding effect by the insert part without exerting a vertical pushing effect or undesirable tearing action).
- the annular transition part has a radial extension (measured from the junction with the fitment part) that is greater than a maximum of radial extension of the insert part.
- in the fully open configuration, the flexible bag defines an upper face that is facing or is in contact with a continuously curved outer surface that connects tangentially with an annular outer surface defined by the insert part, the curved outer surface having an upper portion adjacent to a groove in which the upper rim is engaged.
- the frame comprises a levelling element provided with two opposite ends and a rigid free edge that extends transversally to the central axis, between the two opposite ends, the levelling element being adjacent to a same axial guiding extension at each of the two opposite ends.
- the frame comprises at least one resilient sealing element more flexible than the axial extensions (preferably an annular gasket) to define one or more radial contacts between the bag - at an upper part thereof - and the frame.
- the two opposite inner faces are less spaced in an area proximate the bottom of the container, so as to have less interspace between the bag and the container in a lower part of the interior volume.

BRIEF DESCRIPTION OF THE DRAWINGS

Other features and advantages of the invention will become apparent in the course of the following description, which is given by way of non-restrictive example with reference to the figures, in which:

- Figure 1 is an exploded perspective view of a packaging according to a first embodiment in accordance with the invention, showing the lid in the open position and the inner gusset bag arranged in the interior volume of the outer container;

5 - Figure 2 is a cross section through the upper part of the packaging of Figure 1 showing the lid almost in the closed position and the insert part inserted through the mouth of the bag;

- Figure 3 is a perspective view of a measuring utensil that can be retained below the lid in a storage position according to the invention;

10 - Figure 4a and 4b are two successive perspective views (not showing the lid for sake of simplicity) illustrating the guiding effect of the insert part when inserted through the mouth of the gusset bag;

- Figure 5 is a top view of a packaging according to a second embodiment in accordance with the invention;

15 - Figure 6 is a perspective view of the unopened gusset bag that can be used as a refill;

- Figure 7 illustrates in cross section a stacking between two outer containers;

- Figure 8 is a cross section view through a packaging according to the invention, showing a levelling operation.

DETAILED DESCRIPTION

20 In the various figures, identical reference numerals designate identical or similar elements.

It should be noted that the following detailed description and illustration are directed to a packaging 1 including a box and a flexible gusset pouch or similar bag B that is not resealable (not tightly closed after removal of a top portion), the packaging
25 being well adapted for easy retrieval of the food product contained in the bag B. A variety of products may be contained in the bag B, preferably food products such as powdered milk, dry or powdered beverages, dry soups, coffee, tea, whey powder or the like, butter milk powder, spices, and other flowable solid food products.

Referring to Figures 1-2 and 7, the packaging 1 comprises a container 2 and a
30 closure system 3. The container 2 is open on one side opposite its bottom 20 and may be parallelepiped-shaped, provided with an oval section or any shape with a bottom substantially as wide as the opening, as those skilled in the art will understand. An annular side wall 4 of the container 2 extends about a vertical central axis X to a top 2a
35 defining a peripheral upper rim 21a. An outer collar 2c may be provided and the top 2a may be defined as an annular projection protruding upwardly from an upper face

defined by the collar 2c. A wide opening 21 enclosed by a perimeter 22 is defined by the rim 21a that is rigid (the optional collar 2c increases rigidity of the rim 21a to prevent any deformation).

5 The cross section perpendicular to the central axis X of the container 2 may be basically rectangular with rounded corners. It ensures vertical strength of the packagings 1 when stacked. Fig. 7 shows in more detail a way of stacking the packagings 1, using a recess at the bottom 20 to at least partly house the top wall 33 of the lid 32. For reasons of convenient handling, again, the cross section is preferably inscribed in a rectangle measuring 100 to 140 mm by 80 or 90 to 125 mm. The interior
10 volume V of the container 2 has a determined height H, which is here close to the whole height of the container 2. The bottom 20 may be provided with bearing means 20a, for example feet or an annular base that may protrude downwardly with respect to the planar wall of the bottom 20. Such bearing means 20a can reinforce the strength of the bottom 20 when configured as an additional outer layer of the container 2. The
15 lower part 40 of the sidewall 4 may be of slightly narrower section as illustrated in Fig. 1.

When the sidewall 4 of the container 2 has a rectangular cross section, two opposite inner faces F1, F2 are defined by planar panels and the distance between these inner faces F1, F2 may correspond to a width of the interior volume V. The
20 determined height H, here measured from a planar inner face F3 of the bottom 20 to the top face is preferably between 120 and 190 mm to provide the normal volume for boxes intended to contain infant powdered milk. It is therefore a relatively deep container whose opening 21 must be made as wide as possible to avoid difficulty with extracting powder from close to the bottom 20 of the container 2. In addition, this wide
25 opening 21 allows a measuring utensil 100 to be used to pick up the powder or similar food content 5.

Because of this basically rectangular cross section, shown in Figure 1, the perimeter 22 of the opening 21 of the container 2 may be considered to have a first long side 22a, an opposite second long side 22b, and first and second short sides 22c,
30 22d connecting the long sides. Four corner portions or similar connections 6 may be defined in the sidewall 4 to prevent formation of sharp edges. Here the four panels of the sidewall 4 are provided with four connections 6 each adapted for interconnecting two adjacent panels that form an angle of about 90°.

Without implying any restriction, the container 2 may be made as a single
35 thermally blow-moulded plastic component. The plastic is preferably a multilayer

composite forming a highly effective oxygen barrier where used for a food content 5 such as powdered milk, but the container 2 could of course be produced in some other material, especially metal or a multilayer cartonboard.

Referring to Figs 4a-4b and 6, the food content 5 is stored in the bag B, which
5 has a flexible side wall 8, a bottom 8a and a top portion defined by a closing band 10 intended to be cut or torn. Here, a front wall W1 and a rear wall W2 are interconnected by two opposite gussets 9a, 9b extending parallel to a longitudinal axis of the flexible side wall 8. Welds or sealing junctions can be provided to define the bag B. The closing band 10 may be a sealed part obtained by heat sealing. The bottom 8a can be defined
10 by flaps in an overlapped configuration with a sealing area defined between at least two flaps.

In some embodiments, the bag B can be a mono-web construction of a film. But in preferred embodiments, the front wall W1, the rear wall W2 and the bottom 8a are obtained by assembling at least two different parts. In such case, the bag B includes
15 several seal areas to seal the parts together (e.g., with heat-sealed parts). In a particular embodiment of the present invention as shown in Fig. 6, the bottom 8a is deprived from any gusset and is typically planar. Each of the two gussets 9a, 9b has an interior edge extending between the respective inner faces of the front wall W1 and the rear wall W2 when the bag B is closed by the closing band 10 or similar closing means.

The film material used to form the bag B can be plastic, such as low, medium or
20 high density polyethylene, polypropylene, polyester (PET), polyamide or any other material that is commonly used in the packaging industry, copolymers, or blends thereof. The film material can be a single layer cast or blown film, a multi-layer coextrusion or laminate. The film material can also include one or more layers of paper,
25 metal foil, vacuum deposited metal or inorganic layer of aluminium or silicon oxide and/or a polymer barrier layer, such as ethylene vinyl alcohol or polyvinylidene chloride. These examples are non limiting examples.

It is an important aspect that the material is flexible and capable of allowing a gusset 9a and/or 9b to be formed. Here, the two opposite gussets 9a, 9b are provided
30 adjacent to the wide opening 11. The bag B is therefore a gusset bag. The upper end defined by the upper edges 7 is adapted to define an opening 11 substantially as wide as the bottom 8a, typically with the same shape as the bottom 8a. Besides, if the film is a multi-layer film, it is preferred that at least the inner layer of the bag B is a heat sealable layer.

35 Referring to Fig. 6, the bag B is optionally provided with a top peripheral edge

and, before a cutting or tearing or peeling action to remove such top part of the bag B, the content 5 of the bag B cannot be retrieved through the single opening 11 of the bag B. The top portions of the front wall W1 and of the rear wall W2 are typically in an initial flat configuration, as illustrated in Fig. 6.

5 In other words, the content 5 (powdered milk or other granular or powdery product for example) is perfectly preserved in the bag B until used for the first time when the top peripheral edge (here defined by the closing band 10) is removed, optionally with the aid of one or more peeling-off tongues, tearing tongues, weakened areas or the like.

10 Referring to Fig. 6, the closing band 10 or similar top portion of the bag B is preferably provided with a line of weakness (at the dash line) that extends laterally across both walls W1 and W2 in close proximity to but below the top peripheral edge. The line of weakness may be formed by, for example, perforating or scoring the front wall W1, the rear wall W2 and other optional flaps with a laser or knife either
15 individually before these walls W1 and W2 are sealed together, or collectively after they have been sealed together. One or both ends of line of weakness may terminate with a notch (not shown), which provides a stress concentration and aids in starting a tear along the line of weakness when the bag B is opened by a consumer.

Here, as simple cut along the dash line (a rectilinear dash line in this non
20 limiting example as shown in Fig. 6) is sufficient to provide access to the content 5 because the side wall 8 of the bag B expands in a sufficient extent so that the respective top portions of the front wall W1 and of the rear wall W2 are not in the initial flat configuration. Preferably, the upper level of the food content 5 extends at an axial distance from the upper edges 7 that extend along a cut line that corresponds to the
25 dash line (for example, the upper level is between 25 and 90 mm below the level of the edges 7).

Inside the bag B, the initial level of the food content 5, typically powder material, corresponds to a height H3 that is significantly lower than a predetermined height H2 of the bag B when the bag B is in a fully open configuration (as shown in Fig. 4b for
30 example). The ratio H3:H2 may be comprised between 1:2 and 4:5 in some embodiments.

Now referring to Figs 1-2 and 4a-4b, it can be seen that the bag B, once open, can be stored in the interior volume V of the container 2. Of course, the gusset bag B can also be stored in the container 2 and then opened by excising the closing band 10.

35 While the interior volume V is here illustrated as fully matching wit the outer

shape of the container 2, it is understood that such interior volume V can be adjusted depending on specific configuration inside the container 2. The height H2 of the bag B is inferior to the determined height H so that the upper rim 21a extends entirely above the upper edges 7 of the bag B. The annular side wall 8 of the bag B has a shape
5 matching with the sidewall 4 of the outer container 2 so as to prevent the bag B to be eccentrically positioned inside the interior volume V. In other words, the position of the bag B with respect to the container 2 before fixing the frame 31 is a predetermined position.

The closure system 3 is here provided with an annular fitment part 13 that
10 comprises a peripheral groove G, in which the upper rim 21a is fitted (the annular projection defined by the top 2a being here received in the groove G). The fitment part 13 is here configured as a top part of an annular frame 31 that surrounds the opening 21.

The closure system 3 also comprises a lid 32 hinged to the frame 31 to allow
15 movement of the lid 32 between an open position and a closed position. The frame 31 is thus directly fixed in a removable and tight manner to the peripheral upper rim 21a, while the lid 32 closes the opening 21 of the container 2 when engaged with the fitment part 13 of the frame 31. The lid 32 comprises a top wall 33 and is provided with a circumferential side wall 34 extending from the top wall 33 and an interior skirt 36
20 regularly spaced from the circumferential side wall so as to define with the side wall 34 a continuous groove CG. With such configuration, the fitment part 13 may be received in the continuous groove CG. The inner face of the fitment part 13 may optionally be in radial contact with the interior skirt 36 in the closed position of the lid 32 (the interior skirt 36 pressing at least partially against such inner face of the annular fitment part),
25 so as to prevent the food content 5 (in a powder form for example) to accumulate in a lid-frame contact area 25. Here as illustrated in Fig. 2, such contact area 25 is provided between an outer angled surface of the fitment part 13 and a sealing surface of the circumferential side wall 34. Accordingly, the lid 32 can be repeatedly closed with an efficient sealing effect.

The top wall 33 is here substantially planar to reduce the height of the lid 32.
30 The frame 31 is provided with an insert part 35 optionally making the frame 31 higher than the lid 32. The lid 32 and the frame 31 are articulated together via a connection that allows the lid 32 to be moved with respect to the frame 31 and to the container 2 between an open position depicted in Figure 1, in which the opening 21 is largely
35 accessible, and a closed position, depicted in Figure 7 for example, in which the lid 32

covers this opening 21. This then is a resealable packaging the lid 32 of which is handled on each occasion, for example for preparing baby bottles.

The connection in this instance is a hinged connection 16 (typically one or more living hinges) in which the axis of pivoting is perpendicular to the central axis X. In the embodiment depicted, it is a plastic hinge 16 formed by a fold line, which allows the lid 32 and the frame 31 to be produced as a single component. This is a component obtained by injecting a plastic, such as polypropylene for example, into a mould. However, the hinged connection 16 could of course be obtained using two separate components assembled with one another, and it is equally possible to provide some other form of connection between the frame 31 and the lid 32.

Referring to Fig. 1, the frame 31 may have substantially the same general circumference as the lid 32 and here comprises first and second short outer sides 31c, 31d defined by the fitment part 13, matching with the first and second short sides 22c, 22d.

While the depicted embodiments show a central axis X, which is a symmetry axis for the container 2 and for the frame 31, of course other configurations may be used, depending on the geometry of the container sidewall 4. The frame 31 has not necessarily the same shape as the section of the interior volume V. In optional embodiments with partitioning elements, the sidewall 4 that surrounds the interior volume V for receiving the bag B may correspond to a part of the container side periphery and includes a partitioning element used to define the upper rim 21a.

Referring to Figs 1 and 5, the fitment part 13 or the container 2 has a projecting member with an engagement rim 18 used for locking. Such engagement rim 18 may be integrally formed with the annular collar 2c of the container 2. The packaging 1 has here a locking device provided with a tab T that protrudes downwardly from the lid 32, here from the side wall 34. When the lid 31 is in the closed position, the tab T occupies an engagement position in which a lower catching portion 19 engages with the engagement rim 18. Unlocking is performed by actuating the tab T by hand towards a radially outward direction (typically a pulling action). In the closed position, as shown in Fig. 7, the lid 32 is adjusted and fitted so that a continuous sealing contact is obtained between the fitment part 13 and the lid 32.

Now referring to Figs 1-2, 4a-4b and 8, the pressing to maintain the top of the gusset bag B in a fully open configuration, thanks to an insert part 35 of the frame 31, will be described.

The bag B, filled with the food content 5, open and stored in the interior volume

V, is in contact with the bottom 20 of the container 2 and cannot substantially move because of the small play between the side wall 8 and all or part of the inner faces of the sidewall 4 of the container 2. Indeed, the annular side wall 8 has here a shape matching with the sidewall 4. The bag B thus cannot be eccentrically positioned inside the interior volume V. In some options, the lower part 40 that is preferably of lower height H4 than height H3 is configured to locally reduce or suppress the small gap around the bag B (reduction of size in the lower part 90 of the interior volume V). It is thus understood that the container 2 is configured to define a predetermined position for the bag B having the opening 11 facing upwardly.

10 In this configuration without the closure system 3 fitted onto the upper rim 21a, the bag B is typically not in a fully open configuration. Each of the panels of the sidewall 4 extends between two connections 6 that each correspond to an angle, preferably of about 90° as shown in the depicted embodiments. When such kind of angle is defined between two adjacent panels of the container 2, it is understood that the corresponding corner portions of the bag B (stored in the interior volume V) cannot be sufficiently close to the connections 6. Indeed, significant folds or recessed parts (typically at the gussets 9a, 9b) are typically formed, as shown in Fig. 1 for example.

The flexible side wall 8, here because of the gussets 9a, 9b, can unfold from a partially open configuration to a fully open configuration, providing that the upper edges 7 are displaced (under a pressing action) and held in position away from the central axis X and along the sidewall 4 of the container 2. For this purpose, the frame 31 comprises an insert part 35 that extends in the interior volume V when the fitment part 13 is covering the upper rim 21a with a tight annular contact, and which is intended to be received inside the bag B (above the level of the food content 5). In Fig. 1, the folding in the partially open configuration is a bit exaggerated to better illustrate that the edges 7 are irregularly spaced from the sidewall 4.

The insert part 35 is radially spaced inwardly with respect to the sidewall 4 of the container 2, such spacing being here obtained because of an annular transition part 38 that interconnects the insert part 35 (interior part of the frame 31) and the fitment part 13 (exterior part of the frame 31).

The annular transition part 38 can be radially connected to the fitment part 13 as shown in Fig. 8, below the tight connection between the fitment part 13 and the upper rim 21a. Accordingly, the food content 5 cannot escape from the container 2 because of:

35 – the tight contact at the groove G;

– the continuous contact at the groove CG, preferably using an interior skirt 36; and if the packaging 1 is turned upside down, the food content 5 will necessarily return inside the bag B (after, in normal position) because the powder or content particles cannot be displaced beyond the concave surface S38, due to the pressing contact
5 between the top peripheral part of the bag B (at the upper edges 7, such top is in a stretched condition) and the frame 31 (at the continuous transition part 38 and/or at the continuous annular upper end of the insert part 35).

In order to improve the radial contact, the frame 31 may comprise at least one resilient sealing element (not shown) more flexible than the axial extensions E1, E2,
10 E3, E4 and protruding radially outwards from the outer faces F5, below the fitment part 13. An annular gasket or similar annular resilient element, which is preferably provided near the transition part 38 (and typically entirely above the notches 61, 62, 63, 64), defines one or more radial contacts between the bag B and the frame 31. Such resilient element may be curved or angled to facilitate insertion of the insert part 35 through the
15 opening 11.

Referring to Fig. 2, the insert part 35 extends annularly entirely below the upper rim 21a and preferably entirely below the optional annular collar 2c. The annular transition part 38 extends substantially at the same level as the collar 2c and tapers downwardly, defining a circumferential concave surface S38 facing outwardly. In the
20 inserted configuration of the insert part 35, the transition part 38 may abut against the upper edges 7 of the flexible gusset bag B to hold these upper edges 7 in a proximal position relative to the inner face (including the opposite faces F1 and F2) of the sidewall 4. In some embodiments, the upper edges 7 are only facing such concave surface S38, without continuous or local axial contact against this transition part 38.

The insert part 35 is provided with a plurality of axial guiding extensions E1, E2, E3, E4 configured to engage the bag B through the opening 11. When mounting the closure system 3 with the bag B already extending in the interior volume V, the insert part 35 is sufficiently spaced from the container sidewall 4 to allow the upper edges 7 of the bag B to completely surround the skirt-like insert part 35 with a small play. The
30 guiding extensions E1, E2, E3, E4 are engaging, through the opening 11, the top of the bag B at opposite inner parts (corners or opposite sides). Due to the pressing action of the guiding extensions E1, E2, E3, E4, in the fitted configuration of the closure system 3, these localized parts of the bag B are firstly displaced outwards and then held in a stationary and adjacent position with respect to the respective inner faces of the
35 container 2.

The axial guiding extensions E1, E2, E3, E4 are not stretching or tensing the side wall 8 of the bag B beyond a virtual cuboid that is defined by the bottom 8a of the bag B. Accordingly, when the frame 31 is in a mounted state as shown in Figs 4b or 7, each face of the side wall 8 of the bag B may be substantially planar. With this configuration, a wide and constant section of the bag B is obtained, which is optimal to retrieve food content 5 near the bottom 8a, using a measuring utensil 100.

The axial guiding extensions E1, E2, E3, E4 have a height H1 that is greater than length of the each of the two lower rectilinear edge portions defined at the free end (L-shaped free edge FE) of the guiding axial extension E1, E2, E3, E4. Such height H1 may optionally correspond to a maximum height of the insert part 31 and is typically comprised between 5 and 40 mm.

A polygonal shape with at least four angles for both the sidewall 4 and the side wall 8 of the bag B is preferred because the inner faces of the container 2 may be substantially planar and the axial guiding extensions E1, E2, E3, E4 may be each provided with one planar guiding section or two planar guiding sections 28, 29 configured with a L-shape when viewed in a plane perpendicular to the central axis (X). The upper edges 7 defined at each side of the bag B are thus held in a substantially rectilinear position, without significant undulations in a transverse plane (no folding perceived by the user). Angle of the L-shape may be not inferior to 90°, which is of interest to provide a guiding effect in two distinct directions by a same member of the insert part 35. Each axial guiding extension E1, E2, E3, E4 is provided with a curved midsection 67 (Fig. 4a), which defines a radius of curvature much smaller than the radius of curvature at the connections 6 or at the ends of the shorts sides 31c, 31d.

The transition part 38 is longitudinally curved to be tangentially connected to the insert part 35 that has a small radial deviation as compared to the longitudinal axis X. But such small deviation is of interest to progressively increase the pressing toward the inner faces F1, F2 of the container sidewall 4. It can be seen that the axial extensions E1, E2, E3, E4 are each less slanted than the transition part 38. The higher deviation of the transition part 38 and the substantially continuous curvature (with no horizontal surface) of the transition part 38 is here advantageous to prevent powder to accumulate on the transition part 38, i.e. out of the bag B.

When the polygonal shape is a rectangular or square shape, the sidewall 4 of the container 2 is defined by four panels interconnected at the respective connections 6 that extend each rectilinearly from the bottom 20 to an angle 211, 212, 213, 214 of the peripheral upper rim 21a, as in the non-limiting embodiment of Fig. 1. The annular side

wall 8 of the bag B is provided with four edges 80 (four longitudinal edges) and has a predetermined periphery sized and shaped so that each of the edges 80 is at less than 3 mm from one of the connections 6 when the bag B is stored in the interior volume V and the upper rim 21a is engaged into a groove G of the fitment part 13. Such
5 parallelepiped gusset bag B is of simple construction and may correspond to a conventional kind of bag.

In the illustrated embodiments, the insert part 35 may comprise four bridge portions 66 interconnected by the axial guiding extensions E1, E2, E3, E4. When the guiding extensions E1, E2, E3, E4 have a L-shape section, the insert part 35 defines
10 four substantially planar outer faces F5. Each of the bridge portions 66 (or similar notched part) tapers toward the bottom 20 with small deviation as compared to the direction of the central axis X. Such small deviation (see Figs 2 and 7 for instance) may be inferior or equal to 10°, preferably less than 4 or 5°. As the extensions E1, E2, E3, E4 protrudes downwardly more than the arched midsections AS, they may deviate
15 slightly more at the free edge FE (but typically with the same deviation angle) where the interspace D2 with the container 2 is maximum. Such tapering is of interest because the gussets 9a and 9b can be here progressively moved toward the two opposite faces F1, F2, preferably planar, when the frame 31 is displaced proximate its fitted position and then fitted. More generally, it ensures a more progressive pressing
20 effect in the opposite directions (toward the different sides 22a, 22b, 22c, 22d of the container 2).

Each of the four bridge portions 66 here comprises:

- a notch 61, 62, 63, 64 extending between two axial guiding extensions E1, E2, E3, E4 (for example the notch 63 extends on same side as and between the two extensions
25 E1 and E4); and
- an arched section AS that extends above the notch 61, 62, 63, 64, between the two axial guiding extensions E1, E2, E3, E4.

It can be seen that each arched section AS may define a midsection of one of the respective outer faces F5 of the insert part 35. With such configuration with four
30 notches 61, 62, 63, 64, each midsection of the upper edges 7 (here it can be seen that at least the shorter sides have a V-profile before the pressing) is pressed only at the end or nearly the end of the mounting of the frame 31 and the upper edges 7 of the bag B may be held in a substantially rectilinear position, along the planar outer faces F5 at the end of the unfolding.

35 In the non limiting embodiment of Fig. 1, here along the short sides 22c and

22d, a first notch 61 and a second notch 62 are located opposite each other. These notches 61, 62 are preferably wider than high and the same applies for additional notches 63, 64 that extend along the long sides 22a, 22d.

5 The almost vertical configuration of the axial extensions E1, E2, E3, E4 is also advantageous because the insert part 35 does not obstruct the bag access. Only the optional retaining device 60 for receiving a measuring utensil 100 protrudes toward the central axis X, as shown in Figs 1-5.

10 In some options, the bag B has an inner circumference provided with an initially energized annular elastic tape 65 (shown in Fig. 4a) interfering with the gussets 9a, 9b and arranged near the upper end. When the closing band 10 is removed, such elastic tape 65 deforms radially outwards so that the bag B automatically unfolds from an initial partially open configuration to another configuration that is close or identical to the fully open configuration. This option may be used to facilitate insertion of the insert part 35 through the opening 11 of the bag B.

15 Now referring to Figs 1-2 and 7, the axial extensions E1, E2, E3, E4 have the same profile in a cross section and have respective L-shaped free edges FE that all extend substantially in a same virtual transverse plane (horizontal plane in usual position of the packaging 1). Of course a lower or higher number of such angled free edges FE could be used, depending on the geometry of the container sidewall 4. Providing at least two diametrically opposed L-shaped extensions or opposite L-shaped extensions along a virtual diagonal is of interest to define at least four distinct radially outward directions for the pressing against the inner faces of the bag B. Accordingly, the opening 11 defined by the upper edges 7 of the bag B is expanded and the edges 7 are adequately positioned at a same axial level in the peripheral upper area around the insert part 35, entirely above the angled free edges FE and above the notches 61, 62, 20 63, 64 in the fitted configuration of the fitment part 13.

25 Here, the small radial gap between the inner face of the container 2 and the upper half of the bag B is substantially constant because the upper edges 7 are not excessively stretched radially outwards. The change of geometrical conformation as illustrated at the top of Figs 4a and 4b occurs at constant surface for the bag (no overstretching causing deformation of bag material).

30 The insert part 35 has a maximum height H1, which is of course lower than the determined height H of the interior volume V, and typically inferior to 30 mm. In preferred embodiments, the following relation is satisfied:

35
$$H - H2 < 5 \text{ mm} < H1$$

where H2 is the predetermined height of the flexible gusset bag B in the fully open configuration. Referring to Fig. 2 and 4b, such arrangement ensures that the upper edges 7 are in the upper part (which is narrower than the lower part with maximum radial distance D2) of the annular interspace defined between the insert part 35 and the corresponding inner face (for example the face F1 or F2) of the container 2.

When the packaging 1 is turned upside down, it is understood that a mass of food content 5 accumulates inside the volume defined by the closure system 3 and around the insert part 35. Here with a bag B having the height H2 as shown in Figs 4a-4b and not radially spaced more than 5 or 6 mm from the container 2 at each side, preferably not more than 2 or 3mm, there is no sufficient empty space around the bag B (see also Fig. 7) to allow significant deformation and folding (even in a tilted position, no significant lateral bulge can be formed). Besides, as the space around the insert part 35 is small, pressure exerted by food content 5 near the edges 7 (when the packaging is turned upside down) is not sufficient to locally deform the bag B, whereby there is no substantial loss of product.

Of course, the insert part 35 may be configured with a reduced number of notches and/or have a difference in height for at least one side of the insert part 35. More generally, the insert part 35 is provided with one or two notches 61, 62, defined between two of the axial guiding extensions E1, E2, E3, E4, and extending along one of the two opposite inner faces F1, F2 (here along the short sides 22c, 22d of the container 2). When having only one notch 62 and two gussets 9a, 9b, it may be easier to slightly tilt the frame 31 toward the side 31c without notch, so that this side 31c will push a first gusset 9a toward the corresponding face F1 or F2. Then the second gusset 9b that is less pressed than the first gusset 9a can unfold through the notch 62.

The notch 61, 62, 63, 64 opens downwardly and is preferably not divided into several slots or thin longitudinal notches. Such notch 61, 62, 63, 64 can be obtained when molding the frame 31 or by a cutting operation. Of course the term "notch" should not be interpreted in a restricted manner, as understood by one skilled in the art.

Now, the arrangement of a device for interacting with a measuring utensil 100 will be described with reference to Figs 2-3, 5 and 7-8.

With regard to the measuring utensil 100 as illustrated in Figs 3 and 5, this is similar to a spoon in the embodiments shown, that is to say it has a cup 101 which defines a fixed measuring volume and is, in such option, substantially cylindrical up to the open side of this cup 101. A handle 102 extends from the cup 101 to a free end. The measuring utensil 100 thus has an elongate form and is made of plastic material or

equivalent material. For a circular container 2, the length of the measuring utensil 100 must of course be less than the inside diameter of the frame 31. For a rectangular container 2, this length must be less than the inside diagonal of the frame 31. The measuring utensil 100 is a measuring device of predetermined form, preferably
5 designed to be sold with the whole packaging 1, possibly without the gusset bag B in some options. But it is understood that the fixed measuring volume of such measuring utensil 100 is specific to the content 5 in question, here a food product such as powdered milk.

When sold with the packaging 1, the measuring utensil 100 may be initially
10 wrapped in a bag, inside the interior volume V and/or below the top wall 33 of the lid 32 or in a separated bag fastened onto an outer surface of the container 2. At least after the first opening of the closure system 3, the measuring utensil 100 can be received through a hole 60a in a retaining device 60 that is formed on the frame 31, and preferably integrally formed with the frame 31. This hole 60a is sized to retain the cup
15 101. The retaining device 60 is here integrally formed with the closure system 3 and extends between at least one base portion connected to the short side 31c and at least one free edge 72 that is optionnally configured as a part of a levelling element 70. The retaining device 60 here extends substantially perpendicular to the central axis X. Referring to Fig. 2, the free edge 72, which is of greater size than the opening side of
20 the cup 101, may be either curved, or rectilinear. The rigid free edge 72 may extend between two opposite ends 73, 74 of the levelling element 70 that are connected to the inner annular face of the frame 31. The levelling element 70 may be connected to two adjacent sides of a polygonal frame (here the rectangular frame 31). The ends 73, 74 may thus be arranged each adjacent to the same axial extension E4 of the insert part
25 35.

As shown in Fig. 8, the base portion BP of the retaining device 60, opposite to the free edge 72, may be defined at a junction with the annular transition part 38 longitudinally extending between the fitment part 13 and the insert part 35. The free edge 72 may be provided with a lower protrusion to perform the levelling without need
30 to tilt the measuring utensil or with a slightly tilted position. The user is thus not obliged to incline the measuring utensil 100 almost vertically which could cause some of the food content 5 to fall out and thereby lead to a mismeasurement.

In a first embodiment as shown in Figs 1-4B and 8, a stabilizing relief 60b or at least one similar projection that protrudes upwardly may be provided adjacent to the
35 free edge 72 and as an extension at a surround 26 of the opening 60. The retaining

device 60 is provided with a hole 60a, for example a circular hole, to store the measuring utensil 100 in a storage position, in which the handle 102 extends entirely above the insert part 35, substantially parallel to the top wall 33 of the lid 32. The cup 101 has a minimum height which is higher than space between the hole 60a and the top wall 33 of the lid 32, so that the measuring utensil 100 cannot escape when the closure system 3 remains in a closed position.

Here the first notch 61 is at least partly adjacent to the cup 101 in the storage position. The cup 101 may extend along an axial guiding extension E4, proximate to the junction between the short side 22c and the long side 22b. The retaining device 60 may be connected to a first side 31c of the frame 31 and optionally to another side adjacent to the first side 31c. When the insert part 35 is provided with two opposite notches 61, 62, the second notch 62 may extend proximate to a second side 31d of the frame 31 which is parallel to the first side 31c. The handle 102 extends from the cup 101 toward such second side 31d.

In order to have the upper face of the lid 32 close to the opening plane defined by the upper rim, the lid 32 is of a substantially flat configuration and is provided with a top wall 33 defining a planar upper face, along which the measuring utensil 100 extends in the storage position. Here the levelling edge 72 is curved.

It can be seen that distance D4 between the hole 60a and the upper rim 21a is typically lower than maximum height H1 of each axial extension E1, E2, E3, E4 and lower than the characteristic size D3 (inner diameter for example) of the hole 60a. A distance D4 lower than 10 mm, preferably lower than 5 or 6 mm may be provided, which means that the interspace D2 between a free edge FE and the outer container 2 can be typically less than 3 or 4 mm. The distance D5 between the hole 60a and the central axis X may thus be of at least 20 or 30 mm, which is of interest for levelling operation (easy access and no need to tilt the measuring utensil 100 more than 45°, even when such utensil has a length similar or greater than the opening size along the short sides 22c, 22d of the container 2 – see Fig. 5 for example).

While Figs 1-4B show a retaining device 60 and/or a free edge 72 of a levelling element 70 in a corner area of a rectangular frame 31, it is understood that such kind of device for interacting with the measuring utensil 100 may be arranged differently. For example Fig. 7 shows a retaining element 60 having a free rectilinear edge 72 arranged perpendicular to the two opposite short sides, at a distance from the corners.

In the variant shown in Fig. 5, it can be seen that the retaining device 60, also formed on the frame 31, is only connected to the first side 31c and is distant from the

curved portions of the frame 31. A clip 69 may be provided adjacent the cup 101 in the storage position to lock this position by engagement with a part of the handle 102. Of course, the retaining device 60 may also form a rectilinear free edge 72.

5 In these different embodiments, the handle 102 is easy to catch and there is no need to touch the measuring utensil 100 at or near the cup 101. The handle 102 of the measuring utensil 100 extends in a plane of the opening 21 or above the upper rim 21a, which means that the consumer fingers will not touch the inner faces of the bag B when catching the measuring utensil 100. This centered position of the handle 100, outside the bag B, is advantageous to avoid contacts that would tend to spoil the food content 5.

10 The packaging 1 may thus combine several features without impairing efficiency of the closure and it can be reused with a new bag B filled with content 5, after removal of the empty bag. The handling of the frame 31 of the closure system 3 is not troublesome and there is no need to place fingers inside the new bag.

15 Clearly, the embodiments described above are not restrictive in any way, and numerous variants as to the geometry of the parts making up the container 2 and the closure system 3 are possible without departing from the scope of the invention as claimed.

20 For instance, while the closure system 3 is here described as made of a single piece of molded plastic, it is understood that an assembly of two or more elements can be used to define the closure system. More generally, it will be obvious that the use of the verb "to comprise" and its conjugations does not exclude the presence of any other elements besides those defined in any claim.

25 The word "a" or "an" preceding an element does not exclude the presence of a plurality of such elements. Any reference sign in the following claims should not be construed as limiting the claim.

CLAIMS

1. A packaging (1) for a food product comprising:
- an outer container (2) longitudinally extending about a central axis (X) from
5 a bottom (20) to an upper face having an opening (21), the outer container (2) having a
peripheral upper rim (21a) delimiting the opening and a sidewall (4) defining an interior
volume (V) of a determined height (H), the sidewall having two opposite inner faces
(F1, F2), preferably planar,
 - a closure system (3) comprising a frame (31) which is annular and fixed in a
10 removable manner to the peripheral upper rim (21a), and a lid (32) which closes the
opening (21) of the container (2) in a closed position, the frame (31) comprising an
upper fitment part (13) covering the upper rim (21a); and
 - a gusset bag (B) filled with food product (5) and flexible, comprising a
bottom (8a), an upper end adapted to define an opening (11) of the bag at the opposite
15 from the bottom, an annular side wall (8) provided with at least one gusset (9a, 9b),
preferably two opposite gussets, so that the bag is adapted to unfold from a partially
open configuration to a fully open configuration;
- characterized in that** the sidewall (4) of the outer container (2) has a shape matching
with the annular side wall (8) of the bag so as to locate the bag (B) in a predetermined
20 position inside the interior volume (V),
- and in that** the lid (32) is hinged to the frame to allow movement of the lid between an
open position and the closed position, the frame (31) further comprising:
- an insert part (35) that extends in the interior volume (V) and is radially spaced
inwardly from the sidewall (4) of the container, the insert part (35) extending
25 annularly entirely below the upper rim (21a),
 - a plurality of axial guiding extensions (E1, E2, E3, E4) that belong to the insert
part and configured to engage the bag through the opening (21) of the bag to
hold open the bag (B), the insert part (35) having a notch (61, 62) defined
between two of the axial guiding extensions, along one of said two opposite
30 inner faces (F1, F2).
2. The packaging according to claim 1, wherein at least one of the two
opposite inner faces (F1, F2) is defined by a panel in contact with the upper fitment part
(13) and extends between two connections (6) that each define an angle, preferably of
about 90°, between two adjacent panels of the sidewall (4) of the outer container (2).
- 35 3. The packaging according to claim 1 or 2, wherein the sidewall (4) of the

outer container (2) is defined by four panels interconnected at respective connections (6) that extend each rectilinearly from the bottom (20) to an angle (211, 212, 213, 214) of the peripheral upper rim (21a), while the annular side wall (8) of the bag (B) is provided with four edges (80) and has a predetermined periphery sized and shaped so that each of the edges (80) is at less than 3 mm from one of the connections (6) when the bag (B) is stored in the interior volume (V) and the upper rim (21a) is engaged into a groove (G) of the fitment part (13).

4. The packaging according to any one of the preceding claims, wherein the notch (61, 62) extends between two planar portions (29) of two axial extensions (E1, E2, E3, E4) that are angled to have each a L-shape section when viewed in a plane perpendicular to the central axis (X).

5. The packaging according to claim 4, wherein the insert part (35) comprises four bridge portions (66) each tapering toward the bottom (20) with small deviation as compared to the central axis (X), said small deviation being preferably inferior or equal to 10°,

and wherein each of the four bridge portions (66) comprises:

- a notch (61, 62, 63, 64) extending between two axial guiding extensions (E1, E2, E3, E4);
- an arched section (AS) that extends above the notch, between the two axial guiding extensions.

6. The packaging according to claim 5, wherein the insert part (35) has four substantially planar outer faces (F5), each arched section (AS) defining a midsection of said outer faces (F5) of the insert part (35).

7. The packaging according to claim 4, 5 or 6, wherein the insert part (35) comprises four axial guiding extensions (E1, E2, E3, E4) that are located entirely inside a virtual cuboid, which has a rectangular first section inferior or equal to a rectangular second section defined by the bottom (8a) of the bag (B).

8. The packaging according to any one of the preceding claims, wherein the insert part (35) has a maximum height (H1) lower than the determined height (H), the following relation being satisfied:

$$H - H2 < 5 \text{ mm} < H1$$

where

H1 is the maximum height of the insert part (35),

H2 is a height of the flexible gusset bag (B) in the fully open configuration, and

H is the determined height of the interior volume (V).

9. The packaging according to any one of the preceding claims, wherein the bag (B) and the container (2) have each a polygonal shape, preferably a rectangular shape, the guiding axial extensions (E1, E2, E3, E4) being provided each with an angled free edge (FE) in order to guide each upper edges of the bag (B) in a peripheral upper area that is defined between the insert part (35) and an upper part of the container (2), entirely above the angled free edges (FE) in a fitted configuration of the fitment part (13).

10. The packaging according to any one of the preceding claims, wherein the insert part (35) is provided with a first notch (61) and a second notch (62) at the opposite from the first notch, each of the first notch and the second notch being wider than high, the bag (B) comprising two opposite gussets (9a, 9b) that unfold through the first notch (61) and the second notch (62), respectively.

11. The packaging according to claim 10, further comprising:

- a measuring utensil (100) having a cup (101) and a handle (102); and
- a retaining device (60) for storing the measuring utensil (100) in a storage position, in which the handle (102) extends entirely above the insert part, wherein the first notch (61) is at least partly adjacent to the cup (101) in the storage position, the retaining device (60) being connected to a first side (31c) of the frame (31), the second notch (62) extending proximate to a second side (31d) of the frame which is parallel to the first side of the frame.

12. The packaging according to claim 10 or 11, wherein the bag (B) has an inner face provided with at least one initially energized annular elastic tape (65) interfering with the gussets (9a, 9b), configured to deform radially outwards so that the bag automatically unfolds from an initial partially open configuration to another configuration that is close or identical to the fully open configuration.

13. The packaging according to any one of the preceding claims, wherein the frame (31) comprises an annular transition part (38) between the insert part (35) and the fitment part (13), the transition part tapering downwardly and defining a concave surface (S38) facing outwardly.

14. The packaging according to claim 13, wherein the frame (31) comprises a retaining device (60) that extends perpendicular to the central axis (X) and provided with a hole (60a), the retaining device (60) being directly connected to the annular transition part (38), preferably at an angled junction adjacent to one of the axial guiding extensions (E1, E2, E3, E4).

15. The packaging according to any one of the preceding claims, wherein

the frame (31) comprises a levelling element (70) provided with:

- a rigid free edge (72) that extends transversally to the central axis (X), and
- two opposite ends (73, 74),

5 the levelling element being adjacent to a same axial guiding extension of the axial guiding extensions (E1, E2, E3, E4) at each of the two opposite ends (73, 74).

16. The packaging according to any one of the preceding claims, wherein the lid (32) comprises an interior skirt (36) pressing at least partially against an inner face of the fitment part (13) in the closed position to prevent the food content (5) to accumulate in a lid-frame contact area.

10 17. The packaging according to any one of the preceding claims, wherein the two opposite inner faces (F1, F2) are less spaced in an area proximate the bottom (20) of the container (2), so as to have less interspace between the bag (B) and the container (2) in a lower part (90) of the interior volume (V).

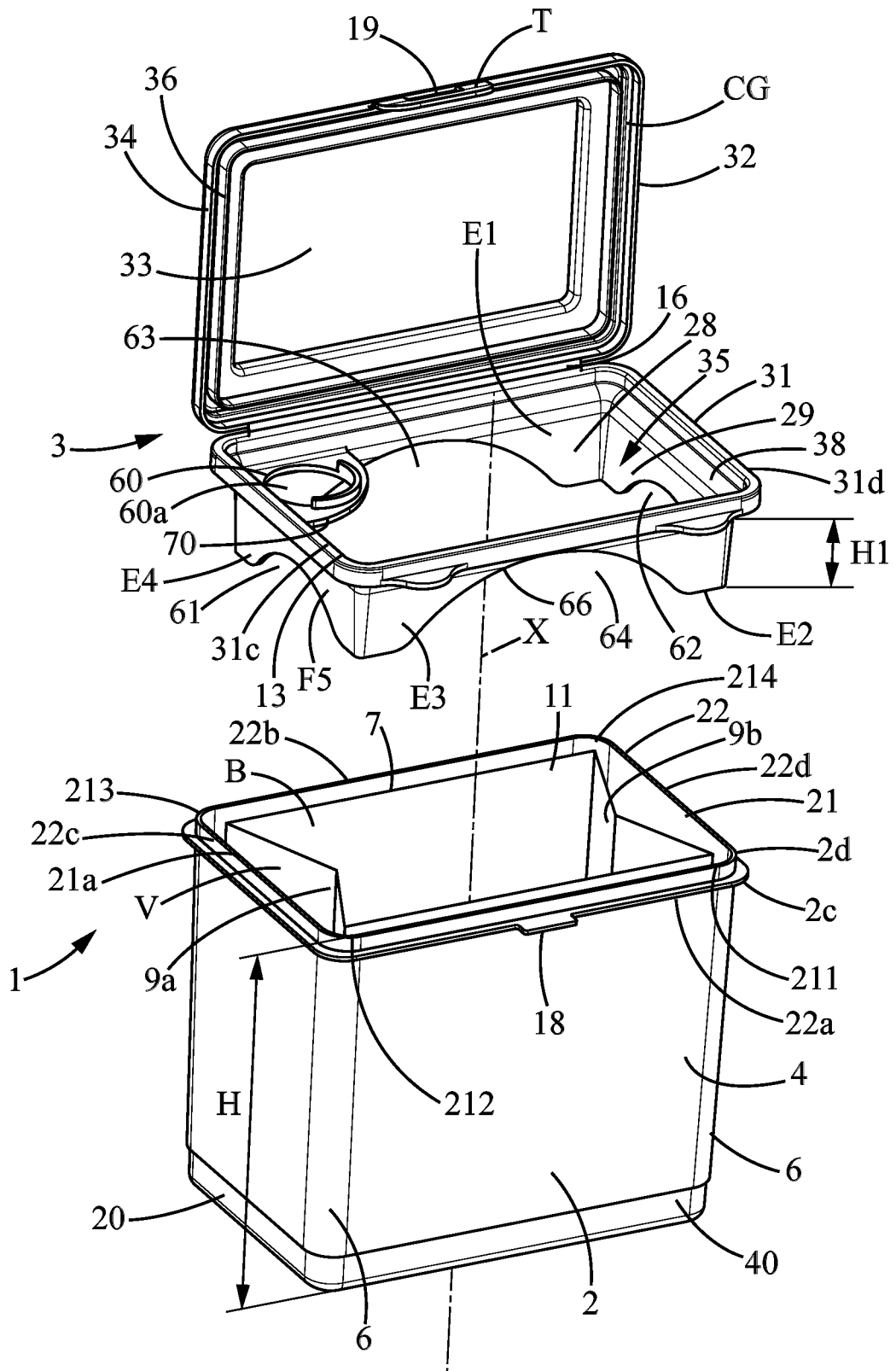

FIG. 1

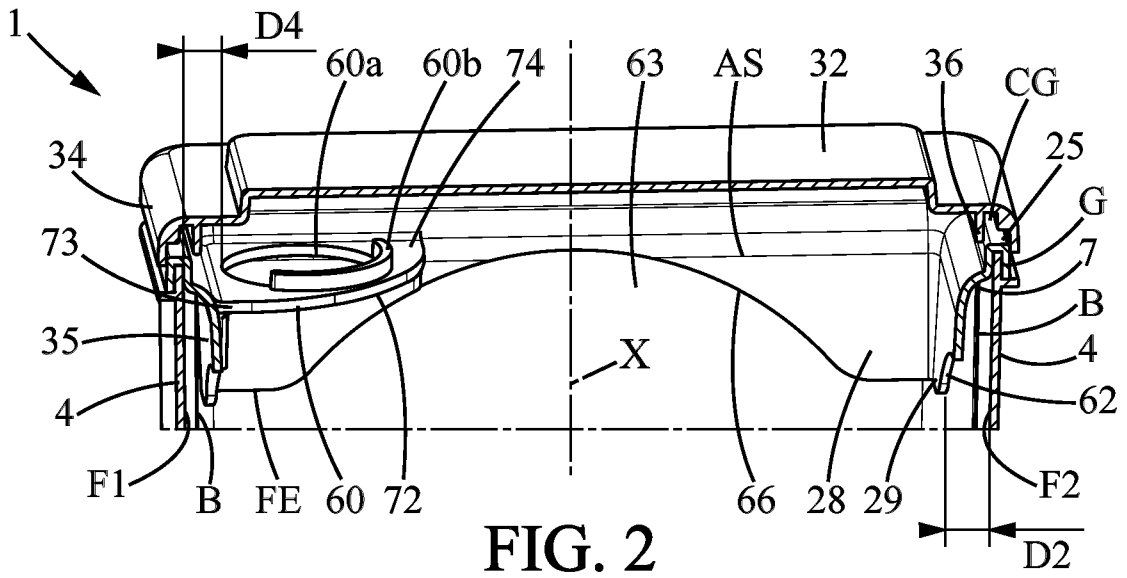

FIG. 2

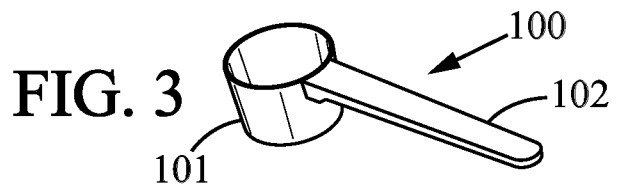

FIG. 3

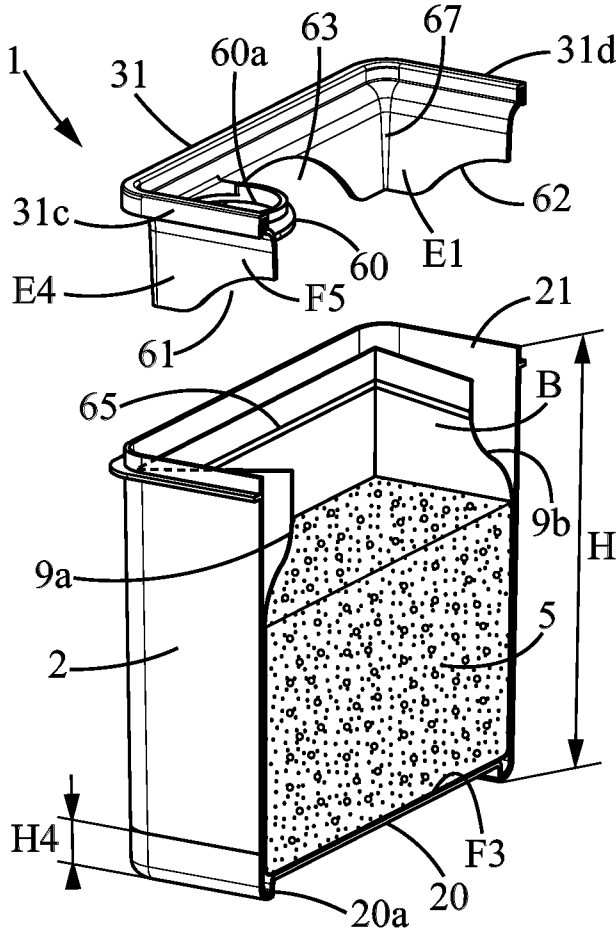

FIG. 4a

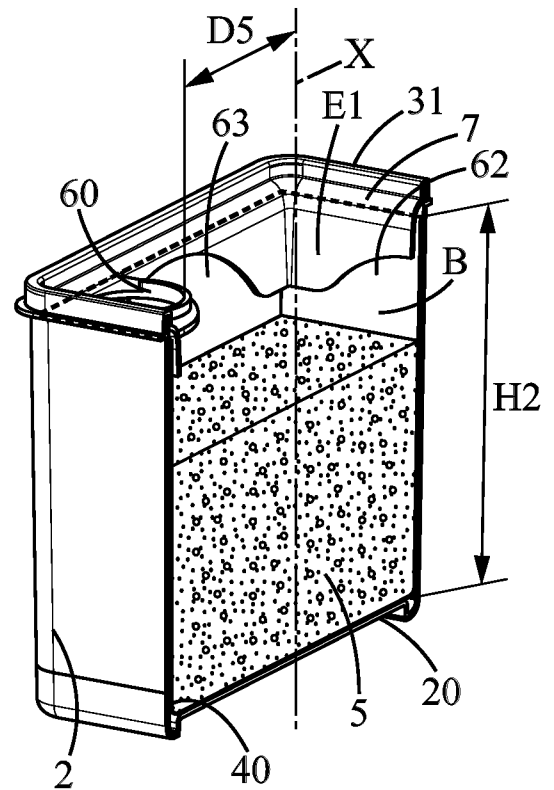

FIG. 4b

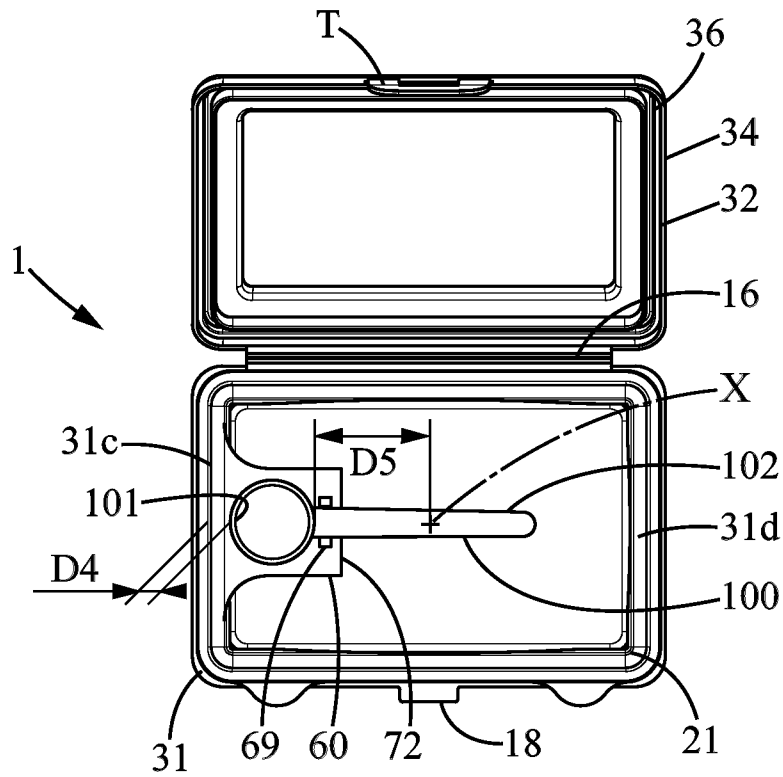

FIG. 5

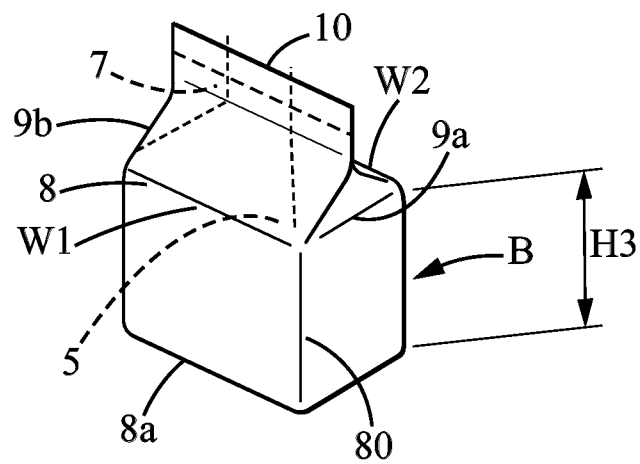

FIG. 6

INTERNATIONAL SEARCH REPORT

International application No
PCT/IB2015/001348

A. CLASSIFICATION OF SUBJECT MATTER
INV. B65D30/20 B65D77/04 B65D77/24 B65D21/02
ADD.
According to International Patent Classification (IPC) or to both national classification and IPC

B. FIELDS SEARCHED
Minimum documentation searched (classification system followed by classification symbols)
B65D
Documentation searched other than minimum documentation to the extent that such documents are included in the fields searched

Electronic data base consulted during the international search (name of data base and, where practicable, search terms used)
EPO-Internal, WPI Data

C. DOCUMENTS CONSIDERED TO BE RELEVANT		
Category*	Citation of document, with indication, where appropriate, of the relevant passages	Relevant to claim No.
A	WO 2012/085117 A1 (NESTEC SA [CH]; VARBANOV PETAR [CH]) 28 June 2012 (2012-06-28) page 6, line 22 - page 10, line 18; figures 1-4	1
A	WO 2008/147082 A1 (CJ CHEILJEDANG CORP [KR]; CHEONG TAE HONG [KR]; PARK EUN JIN [KR]) 4 December 2008 (2008-12-04) paragraph [0035] - paragraph [0036]; figures	1

Further documents are listed in the continuation of Box C.

See patent family annex.

* Special categories of cited documents :

- "A" document defining the general state of the art which is not considered to be of particular relevance
- "E" earlier application or patent but published on or after the international filing date
- "L" document which may throw doubts on priority claim(s) or which is cited to establish the publication date of another citation or other special reason (as specified)
- "O" document referring to an oral disclosure, use, exhibition or other means
- "P" document published prior to the international filing date but later than the priority date claimed

- "T" later document published after the international filing date or priority date and not in conflict with the application but cited to understand the principle or theory underlying the invention
- "X" document of particular relevance; the claimed invention cannot be considered novel or cannot be considered to involve an inventive step when the document is taken alone
- "Y" document of particular relevance; the claimed invention cannot be considered to involve an inventive step when the document is combined with one or more other such documents, such combination being obvious to a person skilled in the art
- "&" document member of the same patent family

Date of the actual completion of the international search 3 March 2016	Date of mailing of the international search report 10/03/2016
--	---

Name and mailing address of the ISA/ European Patent Office, P.B. 5818 Patentlaan 2 NL - 2280 HV Rijswijk Tel. (+31-70) 340-2040, Fax: (+31-70) 340-3016	Authorized officer Newell, Philip
--	---

INTERNATIONAL SEARCH REPORT

Information on patent family members

International application No

PCT/IB2015/001348

Patent document cited in search report	Publication date	Patent family member(s)	Publication date
WO 2012085117 A1	28-06-2012	AU 2011347284 A1	13-06-2013
		CA 2819433 A1	28-06-2012
		CL 2013001840 A1	01-08-2014
		CN 103261052 A	21-08-2013
		EP 2655213 A1	30-10-2013
		RU 2013133987 A	27-01-2015
		SG 190887 A1	31-07-2013
		US 2013277265 A1	24-10-2013
		US 2015001212 A1	01-01-2015
		WO 2012085117 A1	28-06-2012
WO 2008147082 A1	04-12-2008	JP 2010527864 A	19-08-2010
		KR 20080104568 A	03-12-2008
		US 2010133277 A1	03-06-2010
		WO 2008147082 A1	04-12-2008