

(19) World Intellectual Property Organization
International Bureau



(43) International Publication Date
14 May 2009 (14.05.2009)

PCT

(10) International Publication Number
WO 2009/061270 A1

(51) International Patent Classification:

A61F 13/511 (2006.01) A61F 13/472 (2006.01)
A61L 15/44 (2006.01) A61K 9/70 (2006.01)
A61L 15/46 (2006.01) A61L 15/20 (2006.01)
A61F 13/20 (2006.01)

Sten [SE/SE]; Magistervägen 8, S-163 51 Spånga (SE).
SMITH, Jan [SE/SE]; Varpmossevägen 13, S-436 39
Askim (SE).

(21) International Application Number:

PCT/SE2008/051260

(22) International Filing Date:

4 November 2008 (04.11.2008)

(25) Filing Language:

English

(26) Publication Language:

English

(30) Priority Data:

61/001,889 5 November 2007 (05.11.2007) US

(74) Agents: ALBIHNS AB et al.; P.O Box 5581, Linnégatan
2, S-114 85 Stockholm (SE).

(81) Designated States (unless otherwise indicated, for every
kind of national protection available): AE, AG, AL, AM,
AO, AT, AU, AZ, BA, BB, BG, BH, BR, BW, BY, BZ, CA,
CH, CN, CO, CR, CU, CZ, DE, DK, DM, DO, DZ, EC, EE,
EG, ES, FI, GB, GD, GE, GH, GM, GT, HN, HR, HU, ID,
IL, IN, IS, JP, KE, KG, KM, KN, KP, KR, KZ, LA, LC, LK,
LR, LS, LT, LU, LY, MA, MD, ME, MG, MK, MN, MW,
MX, MY, MZ, NA, NG, NI, NO, NZ, OM, PG, PH, PL, PT,
RO, RS, RU, SC, SD, SE, SG, SK, SL, SM, ST, SV, SY, TJ,
TM, TN, TR, TT, TZ, UA, UG, US, UZ, VC, VN, ZA, ZM,
ZW.

(71) Applicant (for all designated States except US): ABIGO
MEDICAL AB [SE/SE]; Ekonomivägen 5, S-436 33
Askim (SE).

(84) Designated States (unless otherwise indicated, for every
kind of regional protection available): ARIPO (BW, GH,
GM, KE, LS, MW, MZ, NA, SD, SL, SZ, TZ, UG, ZM,
ZW), Eurasian (AM, AZ, BY, KG, KZ, MD, RU, TJ, TM),
European (AT, BE, BG, CH, CY, CZ, DE, DK, EE, ES, FI,
FR, GB, GR, HR, HU, IE, IS, IT, LT, LU, LV, MC, MT, NL,

(72) Inventors; and

(75) Inventors/Applicants (for US only): BJÖRNBERG,

[Continued on next page]

(54) Title: DEVICE FOR THE TREATMENT OF VAGINAL FUNGAL INFECTION

Fig.1

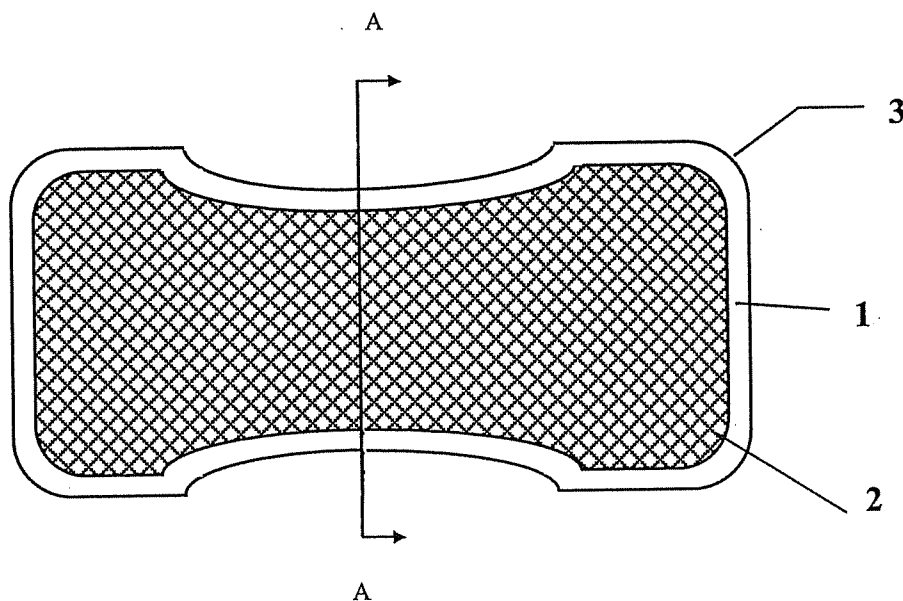

(57) Abstract: An absorbent article, e.g. tampons, sanitary napkins, panty liners and the like, and the process for their preparation in which a hydrophobic and/or cationactive layer is attached to a conventional absorbent layer, for the binding of microorganisms, specifically for treating or alleviating or prophylactically preventing vaginal fungal infections.

WO 2009/061270 A1



NO, PL, PT, RO, SE, SI, SK, TR), OAPI (BF, BJ, CF, CG,
CI, CM, GA, GN, GQ, GW, ML, MR, NE, SN, TD, TG).

Published:

- *with international search report*
- *with information concerning one or more priority claims
considered void*

DEVICE FOR THE TREATMENT OF VAGINAL FUNGAL INFECTION

CROSS-REFERENCE TO RELATED APPLICATIONS

This application claims priority from U.S. provisional application Serial no. 61/001,889 filed November 5, 2007.

BACKGROUND OF THE INVENTION

Field of the Invention

The present invention relates generally to absorbent articles, such as catamenial articles, e.g. tampons, sanitary napkins, panty liners etc. and the process for their preparation. More particularly the invention relates to the combination of a hydrophobic and/or cationactive layer attached to a conventional absorbent layer, for the binding of microorganisms, specifically for treating or alleviating or prophylactically preventing fungal vaginal infections especially from *Candida albicans*.

Description of the Prior Art

The so-called SORBACT® line of products consists of cellulose acetate fabric, cotton gauze or nonwoven (hereinafter named the SORBACT® material) treated with the fatty acid ester, for example DACC (dialkyl carbamoyl chloride) and/or AKD (alkyl ketene dimer). The treatment with fatty acid esters provides the SORBACT® material with a strong hydrophobic property. Numerous studies during the last few decades have shown that pathogenic microorganisms, such as *Staphylococcus aureus*, Group A streptococci and the yeast *Candida albicans* commonly express profound cell surface hydrophobicity. The microorganisms in the exudates from the wound needing to be treated will accompany the flow of liquid absorbed into the absorbing material and come in contact with the hydrophobic component and bind. Another antimicrobial property of the SORBACT® product is its cation activity, described in US Patent application 2006/0163149. The exterior membranes of mammalian cell exterior membranes are generally neutral. Thus the positively charged SORBACT® material preferentially binds to the negatively charged membranes of microorganisms.

The so-called SORBACT®-principle discussed above is a modern and overall effective method for anti-microbial wound healing, which is described in U.S. Patent No. 4,617,326 and U.S. Patent application 2006/0129080. Products utilizing the SORBACT® principle are commercially available. However none of the prior art describes the SORBACT® principle in combination with sanitary protection articles for protection against fungal vaginal infections.

Fungal infections and growth may occur at many places including the human body, e.g. in the vagina or in the oral cavity. Invasive fungal infections are increasing because of the growing number of immunocompromised patients (Jones, J. M. 1990. Laboratory diagnosis of invasive candidiasis. Clin Microbiol Rev 3:32-45). Many of these infections occur in critically ill patients suffering from an underlying disease. Over the past decades “*Candida* overgrowth” has increasingly been a problem as a result of several factors including the abundant use of antibiotics in medicine.

Candida vaginitis is an infection of the vagina. It causes a foul smelling, sticky, white-yellow discharge that may be accompanied by itching, burning and swelling. Such an infection can also make walking, urinating, or intercourse painful. Generally, the vaginal cavity exhibits an aqueous environment containing secreting glands whose fluids create an acidic pH in the range of about 4-5. In its normal state, the lining of the vagina secretes a fluid that is fermented to an acid by bacteria that are normally present. Many women harbor the yeast *Candida albicans* in the vagina and the peripheral areas around the vaginal opening and labia but most have no symptoms and it is harmless to them. This acidity of the vagina is a protective mechanism that helps to protect the vagina from invasion by other microorganisms.

Certain drug therapies can alter the balance of natural microorganisms that are present in the vagina, and hereby promote the growth of *Candida albicans*. Examples include the extended use of antibiotics, steroids and oral contraceptives with high estrogen content. Other factors that may cause *Candida* vaginitis include diabetes, pregnancy, using antihistamines, iron, folate, vitamin B12, or zinc deficiency. Tight fitting pants and the reactions to chemical ingredients found in soaps and detergents may also lead to *Candida* vaginitis.

Treatment with topical antifungal compositions, such as creams or suppositories, is normally the first choice of treatment for mild to moderate yeast infections. Serious infections, however, require a longer course of treatment. Formulation components which are released during the treatment process leak from the vagina creating unsanitary conditions and discomfort and also, more importantly, results in delivery of an unpredictable amount of the

drug.

Another but not so frequent way of treating vaginal fungal infections is by using disposable articles such as tampons in order to decrease the pH. There are a number of common forms of disposable articles that are designed to absorb menstrual fluids discharged from a female's cervix, vaginal tampons, panty liners and sanitary napkins.

A wide variety of absorbent vaginal tampons has long been known in the art. Most currently commercially available tampons are made from a pledget of absorbent material comprising hydrophilic fibers such as cotton or viscose, which has been compressed into a substantially cylindrical form. Pledgets of a variety of types and constructions have been described in the art. Prior to compression, the pledget may be rolled, spirally wound, folded, or assembled as a rectangular pad of absorbent material. Tampons made from a generally rectangular pledget of absorbent material have been popular and successful in the market, for example, the tampon described in U.S. Patent No. 4,294,253. As fluid is absorbed, these compressed tampons are expected to re-expand toward their original pre-compressed size, and to eventually become large enough to effectively cover the vaginal cavity against fluid leakage or bypass

To avoid the discomfort of inserting the tampon into the vagina due to the "dry feel", a liquid pervious non-woven fabric cover layer is used to inhibit the shedding of fibers from the absorbent core. This is known from the disclosure of e.g. U.S. Patent No. 4,816,100 and GB 2,010,680. This is due to the smoother nature of the non-woven fabric. Similar advantages can be obtained using plastics as cover layer material over the absorbent core of a tampon, as described in U.S. Patent No. 5,374,258. Another method to render the tampon more comfortable is using friction-reducing agents for example: pectin hyaluronic acids, glycerides, waxes such as silicone waxes, plant waxes or paraffin as described in U.S. Patent application 2006/074391A1.

Tampons used for the treatment of fungal infections are already described in the art. U.S. Patent No 6,416,779, for example, describes tampons utilized for the treatment of fungal infections by intravaginal administration of therapeutic antifungal drugs to the vagina. Unlike the invention herein the tampon is just a delivery form for drugs and not a method of binding the fungi.

Another way of using sanitary articles for the treatment of fungal infections is by impregnating the tampons with pH-decreasing compounds as described in U.S. Patent application 2006/0264857 and U.S. Patent No. 6,964,949. Further the WO application 1992/013577 discloses a tampon or sanitary napkin that is impregnated with a culture of

living lactic acid producing bacteria, with the object of alleviating vaginal or urinary tract infections. The mechanism behind the antagonistic effect is not completely known but the dominating comprehension is that *Lactobacillus* having antagonistic properties have an ability of coaggregate with the pathogens, to produce inhibitors and to lower pH in the urogenital environment by the lactic acid production. Lactic acid bacteria require special protection during storage and therefore a more stable solution to the problem is preferable.

None of the above inventions and patents, taken either singularly or in combination, is seen to describe the instant invention, i.e. a way of combating vaginal fungal infections utilizing the SORBACT® principle.

A typical sanitary napkin or panty liner includes a liquid pervious topsheet, a liquid impervious backsheet joined to the topsheet, and an absorbent core positioned between the topsheet and the backsheet. Nonwoven webs are often used as the topsheet because they are liquid pervious and provide a skin friendly surface. The absorbing material of the core normally comprises a hydrophilic material such as fibers. Suitable fibers include conventional hydrophilic cellulosic fibers, cotton fibers, viscose fibers or synthetic fibers, for example, polyester, polypropene or combinations thereof, and then pressed to a core.

WO2007073246 discloses an absorbent article for female use, such as a sanitary napkin preventing or reducing migration of microorganisms from the anus area to the urogenital area. This is achieved by a microorganism-hindering element or section, for preventing or reducing migration of microorganisms from the anus area to the urogenital area in the direction from the rear edge to the front edge of the article. The element or section comprises a material selected from one or more of a hydrophobic material, an antimicrobial agent and a positively charged material. The hydrophobic material can be selected from fatty acid esters but not as in the invention herein, which is from the fatty acid esters DACC and AKD, highly hydrophobic and specific for SORBACT® products. Also the microorganism-hindering section is just a limited part of the napkin in contrast to the invention herein where the whole topsheet is made of the SORBACT® material.

There are several known inventions relating to the use of antimicrobial substances and materials. One such example is found in U.S. Patent No. 5,700,742, which relates to a method of treating a textile material to inhibit microbial growth and which comprises applying to the textile material an oligo or polymeric biguanide or salt thereof with an inorganic acid or an organic acid having a pK value above 4.5 followed by a strong organic acid having a pK value below 4.5 and free from any aliphatic or oxyalkylene chain containing 12 or more carbon atoms. A textile material treated in accordance with the claimed method is also

disclosed.

U.S. Patent No. 5,856,248 relates to cellulose fibers and products comprising cellulose fibers treated to absorb body secretions while substantially decreasing microbial growth, the fibers being chemically modified in a two-stage process comprising a first stage treatment with a water soluble salt of a transition metal and an alkali and a second stage treatment with a solution of a bisbiguanide compound, thereby forming a bond between the cellulose fibers, the transition metal and the compound. The process may utilize a rinsing step to neutral pH between the two aforementioned stages.

U.S. Patent No. 5,817,325 relates to an article of manufacture having disposed on a surface thereof a non-leaching antimicrobial coating which kills microorganisms upon contact. The coating comprises an organic polycationic polymer matrix immobilized on the surface having bound or complexed thereto a surface-accessible antimicrobial metallic material such that the antimicrobial material does not release biocidal amounts of elutables into the surrounding environment.

Further, U.S. Patent No. 6,160,196 relates to the same principle but adds thereto an antimicrobial active compound which is adapted to prevent infections from the outside of the pad and the antimicrobial compound is not released into the wound. U.S. Patent No. 4,211,227 discloses a non-woven surgical sponge material comprising a layered fabric having an inner core or a substantially hydrophilic material disposed adjacent at least one outer or surface layer, or between a pair of outer layers, of a substantially hydrophobic material. The sponge material is bonded by passing the material through rolls engraved in a pattern of lands and grooves such that a repeating pattern of three degrees of compression are imposed on the material. However, the so-produced sponge does not use a hydrophobic material binding microorganisms to any great extent.

U.S. Patent Application 2006/0163149 relates to a product for absorption, whereby a hydrophobic entity and a positively charged entity are connected to a support matrix. In this method, the hydrophobic entity may be connected by using DACC, and the positively charged entity may be connected by using polyethyleneimine. Preferred fields of the application are filters, face masks, wound dressings, nasal sprays, and drapes for use during surgical intervention etc. However sanitary protection articles are not mentioned in this application nor are the treatment against fungal vaginal infections.

Even if traditional sanitary protection products solve an important problem absorbing blood, they do not have an antifungal property without additional compounds like drugs, lactic acid bacteria and pH decreasing compounds.

It is therefore a primary object of this invention to provide a device, composition and a method for prevention of fungal vaginal infections especially those caused by *Candida albicans* by providing an intravaginal tampon or a sanitary napkin/panty liner comprising a conventional absorbent covered with a cover layer treated according to the SORBACT® principle.

SUMMARY OF THE INVENTION

A primary object of the present invention is to provide disposable, absorbent articles such as tampons, sanitary napkins and panty liners for the treatment of vaginal fungal infections especially caused by *Candida albicans*. An object of the present invention is to use a hydrophobic and/or cation active material as a cover layer, attached to a conventional absorbent layer, for the binding of the fungi. Another object is to render the cover layer hydrophobic due to the SORBACT® principle i.e. treating the fabric with DACC and/or AKD and/or making the fabric cationic.

Other objects and advantages of the present invention will become obvious to the reader and it is intended that these objects and advantages are within the scope of the present invention.

BRIEF DESCRIPTION OF THE DRAWINGS

Fig. 1 is a plan view of a device, which can be a sanitary napkin or panty liner.

Fig. 2 is a cross-sectional view of the catamenial device of Figure 1.

Fig. 3 is an elevational view of a tampon.

Fig. 4 is a lengthwise cross-sectional view of the tampon of Figure 3.

Fig. 5 is a cross-sectional view of the tampon of Figure 3, perpendicular to the lengthwise axis of the tampon.

Fig. 6 is a top plan view of a catamenial device of Figure 1, including dimensions.

Fig. 7 is a detailed cross-sectional view of a catamenial device, along the arrows in fig.

6

DETAILED DESCRIPTION OF THE INVENTION AND PREFERRED EMBODIMENTS THEREOF

The invention herein relates to absorbent sanitary protection products. The invention is a SORBACT® material combined with the absorbent part of a device comparable to a common catamenial sanitary product such as tampons, sanitary napkins and panty liners. The

invention is able to absorb blood and fluids and at the same time, selectively bind and remove unwanted fungi. The fungi are preferably *Candida albicans* but could be any fungi causing vaginal infections, for example, *Candida crusei* and *Candida parapsilosis*. The fungi bind to the SORBACT® material within 30 seconds. The test in Example 1 shows that the device is a good adsorber of different important and potential pathogens.

Sanitary napkins and panty liners

With respect to the drawings, figure 1 is a perspective view of a device, which may be a sanitary napkin or panty liner or the like, showing the topsheet (1) with SORBACT® properties. The absorbent core (2) is seen through the topsheet (1). The edge (3) is where the topsheet (1) is joined to the backsheet (4) (not shown in this figure). Figure 2 is a cross-sectional view of a device, that can be a sanitary napkin or panty liner or other absorbent device, having a body-contacting topsheet (1), having SORBACT® properties. The topsheet (1) is joined to the backsheet (4), and a core (2), disposed between the topsheet (1) and backsheet (4). The topsheet (1), the backsheet (4) and the absorbent core (2) may be assembled in a variety of well known configurations, exemplary containment assembly configurations are described generally in U.S. Pat. No. 3,860,003

The absorbent core (2) may be any absorbent member which is generally compressible, conformable, non-irritating to the wearer's skin, and capable of absorbing and retaining liquids. The absorbent core (2) may be manufactured in a wide variety of sizes and shapes for example, rectangular, hourglass, "T"-shaped, asymmetric, etc, and from a wide variety of liquid-absorbent materials commonly used in disposable absorbent articles. The absorbing material of the core used in the invention will normally comprise a hydrophilic material such as fibers. Suitable fibers include conventional hydrophilic cellulosic fibers, cotton fibers, viscose fibers, cellulose acetate or synthetic fibers, for example polyester, polypropylene or combinations thereof, which are then pressed to form a core. The absorbent core can contain superabsorbents, for example, sodium acrylate-acrylic-acid polymers or crosslinked dimethyl cellulose.

The backsheet (4) is preferably impervious to liquids and is preferably manufactured from a thin plastic film, although other flexible liquid impervious materials known in the art may also be used. Preferably the backsheet (4) comprises a polymeric film such as thermoplastic films of polyethylene or polypropylene. The basic weight of the backsheet (4) can range between 12-40g/m². The topsheet (1) is positioned adjacent the body-facing surface

of the absorbent core (3) and is preferably joined thereto and to the backsheet (4) making an edge (3), by attachment means (not shown) such as those well known in the art.

The backsheet can also be made of liquid impervious but breathable nonwoven or breathable plastic film.

The topsheet (1) is preferably compliant, soft feeling, and non-irritating to the wearer's skin. Further, the topsheet (1) is liquid pervious permitting liquids to readily penetrate through its thickness. A suitable topsheet (1) is manufactured from a nonwoven or textile web of synthetic fibers (e.g., polyester, polyethylene, or polypropylene fibers or bicomponent fibers). Other suitable fibers include natural fibers such as wood, cotton, or rayon, or combinations of natural and synthetic fibers.

The topsheet (1) is rendered hydrophobic by the treatment with DACC and/or AKD in order to bind the fungi, according to the SORBACT® principle described in U.S. Patent No. 4,617,326 and U.S. Patent Application 2006/0129080. The topsheet (1) is rendered cation active, by means described in U.S. Patent No. 4,617,326 and U.S. Patent application 2006/0129080 or the by application of cationic dyes known in the art. The basis weight of the topsheet (1) can range between 10-100g/m². The backsheet (4) is joined to the absorbent core (3) by attachment means such as those well known in the art. For example, the backsheet (4) may be secured to the absorbent core (3) by a uniform continuous layer of adhesive, a patterned layer of adhesive, or an array of separate lines, spirals, or spots of adhesive. The adhesive could be any well known in the art.

The dimensions of a panty liner of the invention herein are described in, but not limited to figure 6. The length of the panty liner is preferably 155 mm. The length of its absorbent layer is preferably 125 mm and the width is preferably 40 mm. The panty liner is preferably 52 mm at its narrowest spot (in the middle) and 68 mm in its widest spots (at the ends).

The sanitary napkin or panty liner may also be provided with additional features commonly found in sanitary napkins, including "wings" or "flaps" (not shown) as is known in the art, and/or a fluid acquisition layer between the topsheet (1) and the core (2). The topsheet (1) of the device of the present invention may also have lotion composition disposed onto at least the body-contacting surface.

Tampons

With respect to the drawings, figure 3 shows a tampon having a generally cylindrical shape. Surrounding the absorbent core is a liquid pervious cover of the hydrophobic and/or

cationactive SORBACT® material (6). A cord (5) is secured to the end portion for easy removal of the tampon. The introduction end of the tampon is designed as a constriction resembling a round dome. As a result of the pressure applied, the tampon is provided with press notches (grooves) (7) arranged distributed over equal circumferential angles.

Figure 4 is a cross-sectional view of a tampon in its longitudinal direction, having an absorbent core (8) of generally cylindrical shape. Surrounding the absorbent core (8) is a liquid pervious cover layer of hydrophobic and/or cationactive SORBACT® material (6).

Figure 5 is a cross-sectional view of a tampon perpendicular to its linear axis. Surrounding the absorbent core (8) is a liquid pervious cover layer of hydrophobic and/or cationactive SORBACT® material (6). The tampon is pressed radially to give the final form. As a result of the pressure applied, the tampon is provided with press notches (grooves) (7) arranged distributed over equal circumferential angles as shown in Figure 5.

The tampon can be packaged in a conventional cover wrap for use as a digital tampon or within an applicator package for insertion by means of an applicator. The tampon within the wrapper can favorably be sterile. Suitable methods of sterilizing include gamma and electron beam irradiation methods.

As used herein, the term "woven web" refers to a web that has a structure of individual fibers or threads which are joined together in a regular, repeating manner. While the fibers in the "nonwoven web" are not joined together in any regular, repeating manner.

With respect to the above description then, it is to be realized that the optimum dimensional relationships for the parts of the invention, to include variations in size, materials, shape, form, function and manner of operation, assembly and use, are deemed readily apparent and obvious to one skilled in the art. Therefore, the foregoing is considered as illustrative only of the principles of the invention. Further, since numerous modifications and changes will readily occur to those skilled in the art, it is not desired to limit the invention to the exact construction and operation shown and described, and accordingly, all suitable modifications and equivalents may be resorted to, falling within the scope of the invention.

The features of the present invention will be more clearly understood by reference to the following examples, which are not to be construed as limiting the invention.

EXAMPLE 1

Working example tampons

The tampon in figures 3, 4 and 5 has a length of 50 mm and diameter of 12.5 mm and a total weight of 2.5 g with an absorbent core (8) made of 100% viscose fibers (Lenzing

GmbH, Germany). The tampon is surrounded with a cover layer (6) composed of a thermo bonded nonwoven made of polyethylene/polyester with a surface weight of 12g/m² (Far eastern Textile, Taiwan), this nonwoven is made hydrophobic with DACC (Di Alkyle Carbamoyl Chloride) and made cationic by coloring with cationic dyes (Terasil yellow 4G and Teratop blue BGE, CIBA GmbH). The tampon is provided with 120 mm long cotton cord (5), for easy removal of the tampon after use. The cover layer is bonded to the absorbent core by compression. The tampon is compressed to its outer diameter with 8 grooves (7). The final product is covered with cellophane film with a surface weight of 20g/m², to be removed before use.

EXAMPLE 2

Working example panty liners

Panty liner with dimensions according to figures 6 and 7, show the top sheet (1) which is in direct contact with the body, made of a nonwoven Viscose /Polyester fiber with a surface weight of 40g/m² (Aquadim VE 40, from Tharreau Industries, France). This nonwoven is made hydrophobic with DACC (Di Alkyle Carbamoyl Chloride) and made cationic by the coloring with cationic dyes (Terasil yellow 4G and Teratop blue BGE, CIBA GmbH). The topsheet (1) is fastened to an absorbent core (2), with an adhesive (9), (Fuller D8370ZP, Fuller GmbH, Germany). The absorbent core (2) is made of Air laid cellulose, (Concert GmbH, Germany) having a surface weight of 60g/m² having an unfolded width of 155 mm. The absorbent core (2) is folded in to three layers to a final width of 40 mm. The length of the absorbent layer is 125 mm.

Between the absorbent layers there is 0.3g of superabsorbent (10) (Figure 7)(SX Fam, Stockhausen, GmbH) evenly spread or mixed along the whole length of the absorbent layer.

The absorbent layer is fastened, to a backsheet (4) that functions as a moisture barrier, with the same type of adhesive (9) as the top layer (Fuller D8370ZP, Fuller GmbH, Germany). The Backsheet (4) (moisture barrier) is made of polyethylene film with a thickness of 0.02 mm, (Trioplast AB, Sweden). The outside of the panty liner does have a self sticking adhesive (11) (Fuller 3964, Fuller GmbH, Germany) located on the outside of the moisture barrier.

The sticking layer (11) is protected with a Siliconized paper (12) (RP40 Rosella RSL, Italy), which is to be removed before use.

EXAMPLE 3

In vitro test of the tampons and sanitary napkins/panty liners to bind pathogens

Material: The absorbent products as described in Example 1 and 2

Bacterial strains: *Staphylococcus aureus* Newman, *Pseudomonas aeruginosa* 510,
Enterococcus faecalis, *Candida albicans*

Isolates were cultured on agar with 5% horse erythrocytes in 5% CO₂ atmosphere at 37°C. Suspensions were made in phosphate-buffered saline (PBS, 0.02 M sodium phosphate and 0.15 M sodium chloride, pH 7.2) at 10⁹ bacterial cells/ml, 10⁷ fungal cells/ml or indicated concentration.

The products were cut in 1 cm² pieces. Incubation was made in 24 well polymer plates. 1 ml of suspension was added to each piece. The plates were placed on a rotary shaker at very low speed. Incubation was performed at room temperature for the indicated time. After incubation, dressings were rinsed in PBS several times, and then put in 2.5 % TCA (tricarboxylic acid).

The ATP content was measured in a luminometer (LKB Wallac). Controls: Number of adhered bacteria (CFU/ATP) were normalized against total added bacteria (CFU/ATP), and blank (no bacteria, only EDTA-Tris buffer) was the ATP value control.

Results:

S. aureus > 10⁵ cells adhered during 30 sec, 1, 5 and 10 minutes, and then increased to 10⁶ cells after 2 hrs. Some multiplication occurred during the following 24 hrs to reach 5 x 10⁶ cells/cm².

P. aeruginosa Around 10⁶ cells adhered during 30s, 1, 5 and 10 min, and then increased during 30 and 60 min incubation to reach 10⁷ cells/cm² after 2 hrs incubation. No multiplication of adhered bacteria occurred during the following 24 hrs.

We did not reach endpoints for maximal adsorption. When 5 x 10⁹ cells of *S aureus* were added, 10⁸ cells adhered, for *P. aeruginosa* 10⁸ cells adhered out of 10^{9.5} added, and for *E. faecalis* 8 x 10⁶ out of 5 x 10¹⁰ added. For *C. albicans* the slope levels off, 10⁵ cells adhered out of 10^{7.5} added.

The results did not differ between the tampons and the sanitary napkins/panty liners.

EXAMPLE 4

In vivo test of the tampon for the treatment of vaginal Candida albicans infections.

In order to test the effect of the tampons of the invention herein a pilot study was performed. Eight patients participated in the study, and seven of them were given treatment. The patients were women between the ages of 19-45. The anamnesis of six of the eight patients was infrequent fungal-like vaginal infections. For one of the patients the anamnesis was frequent fungal vaginal infection after coitus with the same partner.

Seven of the patients were treated with tampons of the invention herein twice a day for five days. They were prescribed to use the first tampon before bedtime and the second the following day, for four hours. Two of the patients suffered from itching and burning both in the vulva and the vagina, symptoms characteristic of fungal vaginal infections. However they lacked the typical whitish discharge. The treatment with the tampon of the invention herein did not affect the symptoms of these two women. At the next appointment one of the two patients was tested negative for *Candida albicans* (the other patient was not tested at all). The patient suffering from itching and burning after coitus was recommended to insert a tampon after coitus and keeping it overnight. She successfully tested it four times. None of the previous symptoms remained. Four of the remaining five patients became free of symptoms after the recommended treatment. The symptoms of the last of the remaining five patients were clearly improved. With additional per oral fungal treatment the patient became free of symptoms. No side effects were registered.

While the invention has been described with reference to specific embodiments, it will be appreciated that numerous variations, modifications, and embodiments are possible, and accordingly, all such variations, modifications, and embodiments are to be regarded as being within the spirit and scope of the invention.

THE CLAIMSWhat is Claimed Is:

1. A device for treatment of vaginal fungal infections, comprising:
 - a) a core of absorbent material having a shape selected from the group consisting of a flat shape and a cylindrical shape; and
 - b) a liquid pervious layer covering the core and forming a topsheet which is in direct contact with a user of the device, wherein the topsheet is treated to adsorb fungal yeast.
2. The device of claim 1, wherein the core further comprises superabsorbents within or applied to the core.
3. The device of claim 1 wherein the absorbent core is made of fibers selected from the group consisting of a) natural fibers selected from the group consisting of cellulose, viscose cellulose acetate and cotton fibers; and b) synthetic fibers selected from the group consisting of polypropylene, polyester and polypropylene-polyester fibers.
4. The device of claim 3, wherein the core further comprises superabsorbents within or applied to the core.
5. The device of claim 1 wherein topsheet is treated with a substance selected from the group consisting of dialkyl carbamoyl chloride and alkyl ketene dimer.
6. The device of claim 1 wherein the topsheet is positively charged.
7. The device of claim 1 wherein the topsheet is treated with fatty acid esters so that the top layer has a strong hydrophobic property.
8. The device of claim 7 wherein topsheet is treated with a substance selected from the group consisting of dialkyl carbamoyl chloride and alkyl ketene dimer.

9. The device of claim 1 wherein the topsheet is made from a material selected from the group consisting of a) a nonwoven or textile web of synthetic fibers; b) natural fibers; and c) combinations of natural and synthetic fibers.
10. The device of claim 9 wherein the topsheet is made from a material selected from the group consisting of polyester, polyethylene, polypropylene and bicomponent fibers.
11. The device of claim 9 wherein the topsheet is make from a material selected from the group consisting of wood, cotton, rayon, and cellulose acetate.
12. The device of claim 1, wherein the core has a flat shape, and wherein the device further comprises an impervious backsheet on the opposite side of the core as the topsheet..
13. A device for treatment of vaginal fungal infections, comprising:
 - a) a core of absorbent material having a shape selected from the group consisting of a flat shape and a cylindrical shape, and made of fibers selected from the group consisting of a) natural fibers selected from the group consisting of cellulose, viscose cellulose acetate and cotton fibers; and b) synthetic fibers selected from the group consisting of polypropylene, polyester and polypropylene-polyester fibers; and
 - b) a liquid pervious layer covering the core and forming a topsheet which is in direct contact with a user of the device, wherein the topsheet is treated to adsorb fungal yeast with a substance selected from the group consisting of dialkyl carbamoyl chloride and alkyl ketene dimer.
14. The device of claim 13, wherein the core further comprises superabsorbents within or applied to the core.
15. The device of claim 13 wherein the topsheet is positively charged.
16. The device of claim 13 wherein the topsheet is made from a material selected from the group consisting of polyester, polyethylene, polypropylene and bicomponent fibers.
17. The device of claim 13 wherein the topsheet is make from a material selected from the group consisting of wood, cotton, rayon, and cellulose acetate.

18. The device of claim 13, wherein the core has a flat shape, and wherein the device further comprises an impervious backsheet on the opposite side of the core as the topsheet.
19. The device of claim 18, wherein the core comprises three layers of material.
20. A method for prevention of fungal vaginal infections comprising providing the device of claim 13.
21. The method of claim 20, wherein the device is selected from the group consisting of intravaginal tampons, sanitary napkins, and panty liners.
22. The method of claim 20, wherein the fungal vaginal infections are infections of *Candida albicans*.
23. A method of making a device for treatment of vaginal fungal infections, comprising providing:
 - a) a core of absorbent material having a shape selected from the group consisting of a flat shape and a cylindrical shape; and
 - c) a liquid pervious layer covering the core and forming a topsheet which is in direct contact with a user of the device, wherein the topsheet is treated to adsorb fungal yeast.

Fig.1

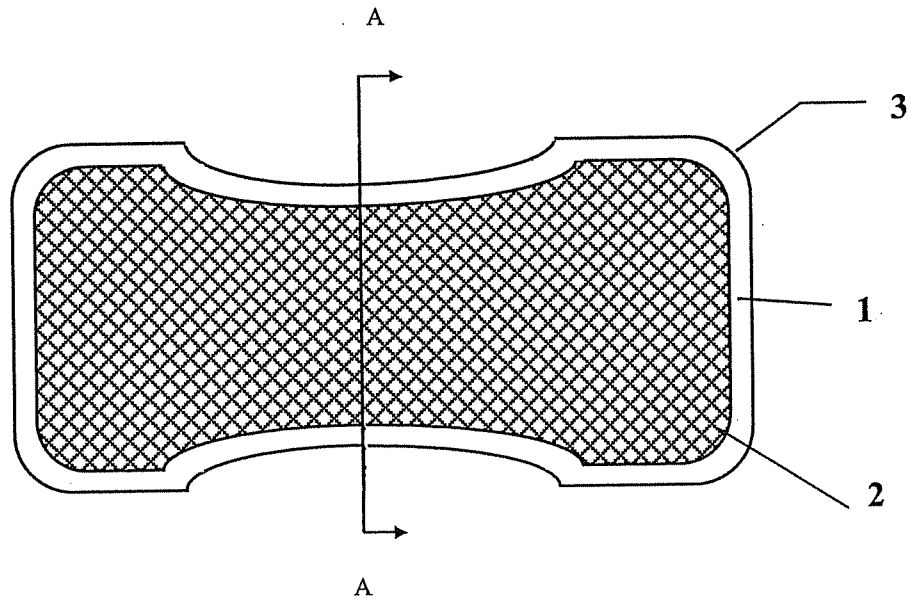

Fig.2

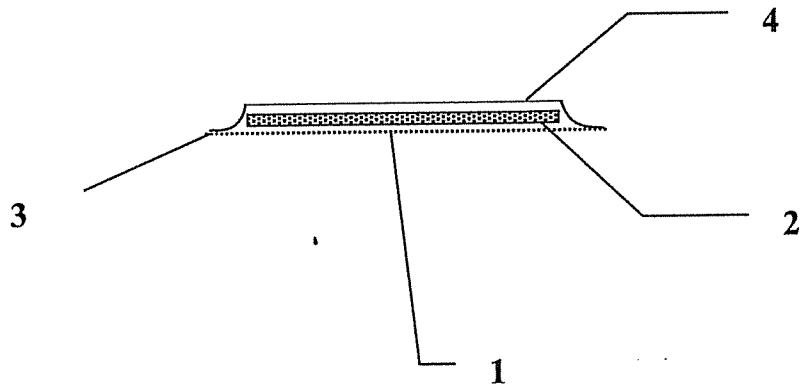

Fig 3

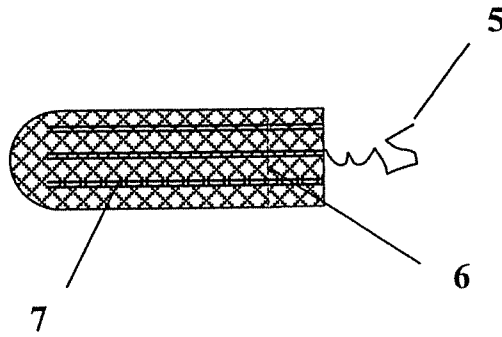

Fig.4

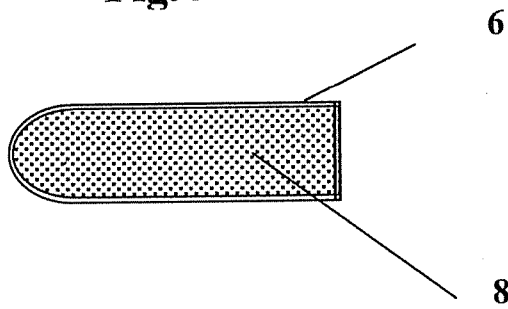
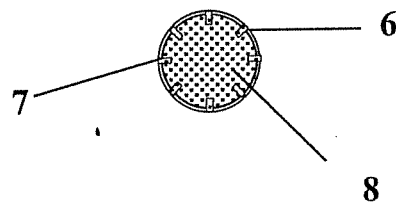

Fig.5



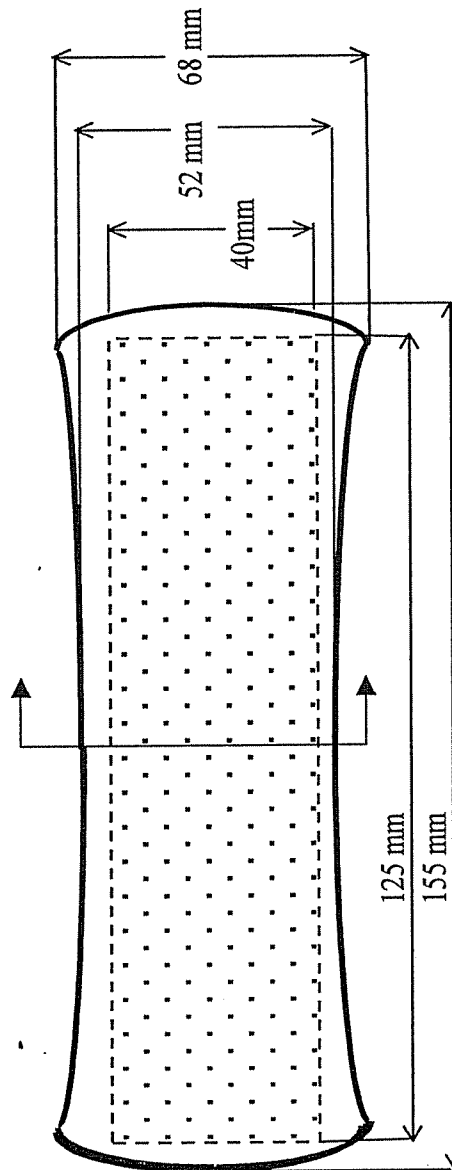
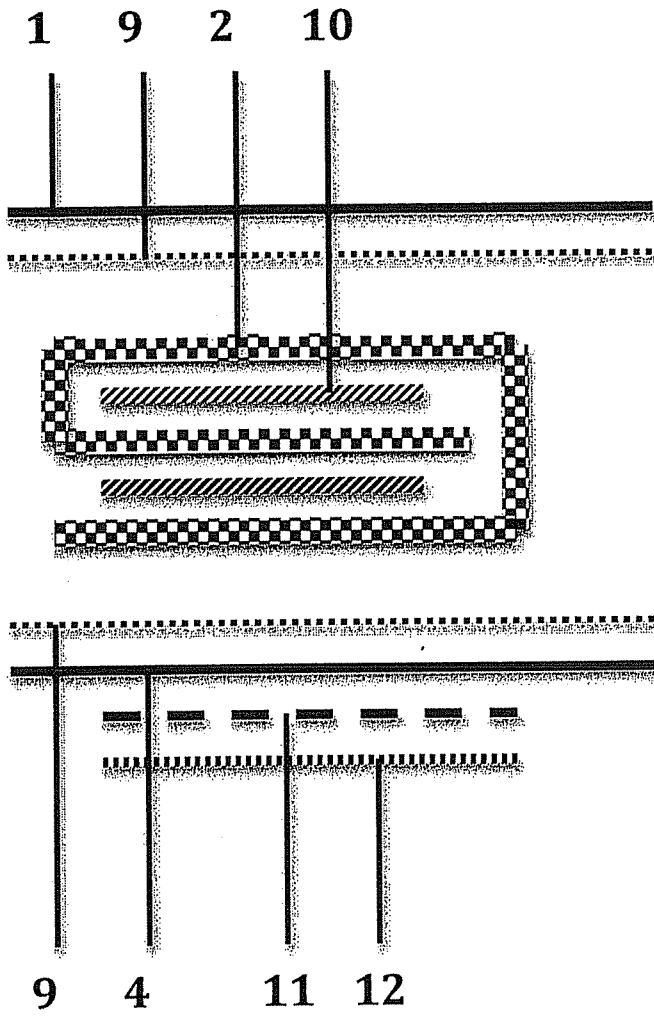

Fig.6

Fig. 7



INTERNATIONAL SEARCH REPORT

International application No.

PCT/SE2008/051260

A. CLASSIFICATION OF SUBJECT MATTER

IPC: see extra sheet

According to International Patent Classification (IPC) or to both national classification and IPC

B. FIELDS SEARCHED

Minimum documentation searched (classification system followed by classification symbols)

IPC: A61F, A61L

Documentation searched other than minimum documentation to the extent that such documents are included in the fields searched

SE,DK,FI,NO classes as above

Electronic data base consulted during the international search (name of data base and, where practicable, search terms used)

EPO-INTERNAL, WPI DATA, PAJ

C. DOCUMENTS CONSIDERED TO BE RELEVANT

Category*	Citation of document, with indication, where appropriate, of the relevant passages	Relevant to claim No.
X	US 4617326 A (BJÖRNBERG STEN G. ET AL), 14 October 1986 (14.10.1986), column 2, line 8 - line 19; column 4, line 46 - line 60; column 5, line 4 - line 8, column 5, line 53 - line 59; examples 1,8,9 and 10, claims 1,4, abstract	1-23
	--	
X	CLAESSON, M. et al, "A promising alternative in the treatment of dermal fungal infections", [online]: BSN medical, 04/2007, abstract, figures 1 and 2 [retrieved on 2009-01-13] Retrieved from the Internet: <URL: http://www.cutimed-sorbact.es/PDF/Fungal_infec.pdf > the whole document	1-23
	--	

Further documents are listed in the continuation of Box C.

See patent family annex.

* Special categories of cited documents:

- "A" document defining the general state of the art which is not considered to be of particular relevance
- "E" earlier application or patent but published on or after the international filing date
- "L" document which may throw doubts on priority claim(s) or which is cited to establish the publication date of another citation or other special reason (as specified)
- "O" document referring to an oral disclosure, use, exhibition or other means
- "P" document published prior to the international filing date but later than the priority date claimed

- "T" later document published after the international filing date or priority date and not in conflict with the application but cited to understand the principle or theory underlying the invention
- "X" document of particular relevance: the claimed invention cannot be considered novel or cannot be considered to involve an inventive step when the document is taken alone
- "Y" document of particular relevance: the claimed invention cannot be considered to involve an inventive step when the document is combined with one or more other such documents, such combination being obvious to a person skilled in the art
- "&" document member of the same patent family

Date of the actual completion of the international search

20 January 2009

Date of mailing of the international search report

22-01-2009

Name and mailing address of the ISA/
Swedish Patent Office
Box 5055, S-102 42 STOCKHOLM
Facsimile No. +46 8 666 02 86

Authorized officer

John Sjöberg/ELY
Telephone No. +46 8 782 25 00

INTERNATIONAL SEARCH REPORT

International application No.

PCT/SE2008/051260

C (Continuation). DOCUMENTS CONSIDERED TO BE RELEVANT

Category*	Citation of document, with indication, where appropriate, of the relevant passages	Relevant to claim No.
X	US 20030224034 A1 (KOENIG DAVID W.), 4 December 2003 (04.12.2003), figure 2, claims 1-10, abstract, paragraphs [0027]-[0029],[0047] --	1,3,9,12
A	WO 2006062470 A1 (ABIGO AB), 15 June 2006 (15.06.2006), abstract, paragraphs [0008],[0028] --	1-23
A	WO 03055535 A1 (ACCANTIA (HOLDINGS) LIMITED), 10 July 2003 (10.07.2003), page 1, line 1 - page 5, line 8, abstract --	1-23
A	WO 9213577 A1 (LECUR DEVELOPMENT IN SWEDEN AKTIEBOLAG), 20 August 1992 (20.08.1992), claims 1-9, abstract --	1-23
A	WO 0141819 A1 (BASF AKTIENGESELLSCHAFT), 14 June 2001 (14.06.2001), abstract, example 1 -- -----	1-23

International patent classification (IPC)

A61F 13/511 (2006.01)

A61L 15/44 (2006.01)

A61L 15/46 (2006.01)

A61F 13/20 (2006.01)

A61F 13/472 (2006.01)

A61K 9/70 (2006.01)

A61L 15/20 (2006.01)

Download your patent documents at www.prv.se

The cited patent documents can be downloaded at www.prv.se by following the links:

- In English/Searches and advisory services/Cited documents (service in English) or
- e-tjänster/anförda dokument (service in Swedish).

Use the application number as username.

The password is **GTFHIZPQTY**.

Paper copies can be ordered at a cost of 50 SEK per copy from PRV InterPat (telephone number 08-782 28 85).

Cited literature, if any, will be enclosed in paper form.

INTERNATIONAL SEARCH REPORT
Information on patent family members

01/11/2008

International application No.

PCT/SE2008/051260

US	4617326	A	14/10/1986	AT	57837	T	15/11/1990
				CA	1254509	A	23/05/1989
				DE	3580300	D	00/00/0000
				DK	112485	A	15/09/1985
				DK	166066	B,C	08/03/1993
				EP	0162026	A,B	21/11/1985
				SE	0162026	T3	
				FI	88258	B,C	15/01/1993
				FI	850996	A	15/09/1985
				JP	1841540	C	12/05/1994
				JP	5052221	B	04/08/1993
				JP	60210256	A	22/10/1985
				NO	172726	B,C	24/05/1993
				NO	850994	A	16/09/1985
				SE	460017	B	04/09/1989
				SE	8401438	A,L	15/09/1985

US	20030224034	A1	04/12/2003	AU	2003228551	A,B	06/09/2007
				BR	PI0310045	A	10/04/2007
				CA	2484972	A	11/12/2003
				EP	1509181	A	02/03/2005
				MX	PA04011297	A	14/02/2005
				WO	03101356	A	11/12/2003

WO	2006062470	A1	15/06/2006	EP	1848467	A	31/10/2007
				US	20060129080	A	15/06/2006

WO	03055535	A1	10/07/2003	AU	2002356308	A	00/00/0000
				EP	1455844	A	15/09/2004
				GB	0130666	D	00/00/0000
				US	20060264857	A	23/11/2006
				ZA	200404810	A	31/05/2006

WO	9213577	A1	20/08/1992	DE	69111809	D,T	18/04/1996
				DE	69230496	D,T	31/08/2000
				DK	594628	T	19/06/2000
				EP	0531385	A,B	17/03/1993
				EP	0594628	A,B	04/05/1994
				SE	0594628	T3	
				ES	2143987	T	01/06/2000
				SE	9100364	A,L	06/08/1992

WO	0141819	A1	14/06/2001	DE	19958697	A	07/06/2001
----	---------	----	------------	----	----------	---	------------