

(19) World Intellectual Property Organization
International Bureau



(43) International Publication Date
10 May 2001 (10.05.2001)

PCT

(10) International Publication Number
WO 01/32013 A1

- (51) International Patent Classification⁷: A01M 1/02, 1/10, 1/20, A01G 29/00, A01C 23/02, A01N 25/00
- (71) Applicant (for all designated States except US): COLORADO STATE UNIVERSITY RESEARCH FOUNDATION [US/US]; P.O. Box 483, Fort Collins, CO 80522 (US).
- (21) International Application Number: PCT/US00/13477
- (72) Inventors; and
- (22) International Filing Date: 17 May 2000 (17.05.2000)
- (75) Inventors/Applicants (for US only): BERNKLAU, Elisa, J. [US/US]; 5605 Sunrise Court, Bellvue, CO 80512 (US). FROMM, Erich, A. [US/US]; 2541 57th Avenue, Greeley, CO 80634 (US). BJOSTAD, Louis, B. [US/US]; 6001 Blue Spruce Drive, Bellvue, CO 80512 (US). MORTON, Henry, Vincent [US/US]; 151 Olive Road, Reidsville, NC 27320 (US).
- (25) Filing Language: English
- (26) Publication Language: English
- (30) Priority Data:
PCT/US99/26074
4 November 1999 (04.11.1999) US
- (74) Agents: KOVARIK, Joseph, E. et al.; Sheridan Ross P.C., Suite 1200, 1560 Broadway, Denver, CO 80202-5141 (US).
- (63) Related by continuation (CON) or continuation-in-part (CIP) to earlier application:
US PCT/US99/26074 (CIP)
Filed on 4 November 1999 (04.11.1999)
- (81) Designated States (national): AE, AL, AM, AT, AU, AZ, BA, BB, BG, BR, BY, CA, CH, CN, CR, CU, CZ, DE, DK, DM, EE, ES, FI, GB, GD, GE, GH, GM, HR, HU, ID, IL,

[Continued on next page]

(54) Title: METHOD AND DEVICE FOR ATTRACTING INSECTS

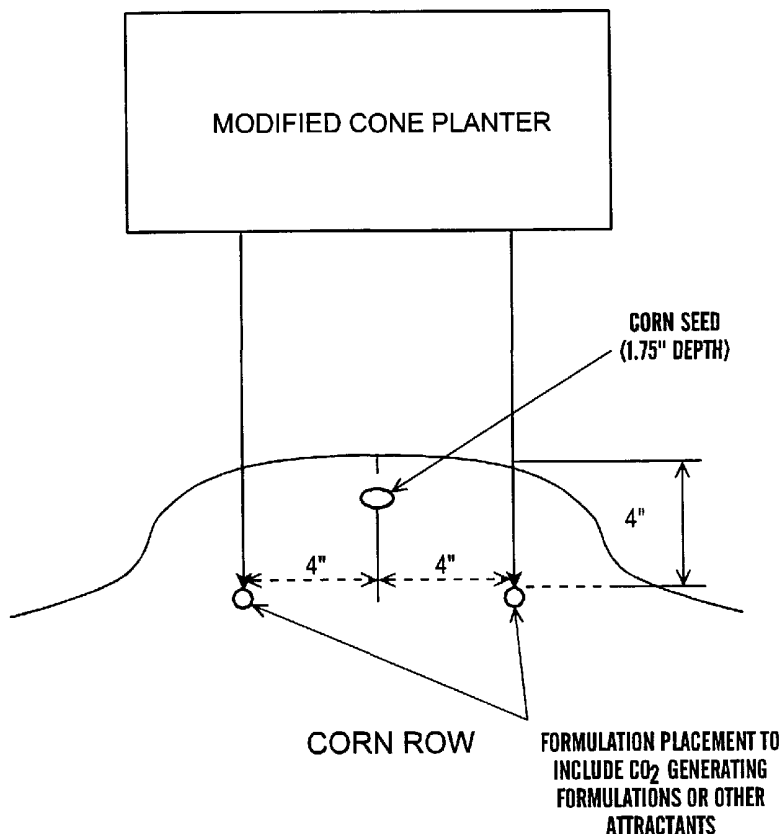

(57) Abstract: A method and device for attracting insects involving the generation and/or release of particular amounts of carbon dioxide, in combination with an insecticide that does not repel such insects. Particular formulations as well as devices which incorporate such formulations for trapping, attracting and destruction of particular insects, including boring insects, such as termites and corn root worm insects, is set forth. Particular methods of administration of formulations and devices to enhance insect control and to prevent crop damage are disclosed.



WO 01/32013 A1



IN, IS, JP, KE, KG, KP, KR, KZ, LC, LK, LR, LS, LT, LU,
LV, MA, MD, MG, MK, MN, MW, MX, NO, NZ, PL, PT,
RO, RU, SD, SE, SG, SI, SK, SL, TJ, TM, TR, TT, TZ, UA,
UG, US, UZ, VN, YU, ZA, ZW.

MC, NL, PT, SE), OAPI patent (BF, BJ, CF, CG, CI, CM,
GA, GN, GW, ML, MR, NE, SN, TD, TG).

Published:

— *With international search report.*

(84) Designated States (regional): ARIPO patent (GH, GM,
KE, LS, MW, SD, SL, SZ, TZ, UG, ZW), Eurasian patent
(AM, AZ, BY, KG, KZ, MD, RU, TJ, TM), European patent
(AT, BE, CH, CY, DE, DK, ES, FI, FR, GB, GR, IE, IT, LU,

For two-letter codes and other abbreviations, refer to the "Guidance Notes on Codes and Abbreviations" appearing at the beginning of each regular issue of the PCT Gazette.

METHOD AND DEVICE FOR ATTRACTING INSECTS

RELATED APPLICATION

This application in a continuation-in-part application of PCT/US99/26074 filed
5 November 4, 1999, in which the U.S. has been designated.

FIELD OF THE INVENTION

The present invention is directed to a method and device for attracting certain
insects, and more particularly is directed to a method and device for attracting termites
10 to ultimately trap or otherwise destroy such termites, as well as a method to reduce
damage caused by corn root worms.

BACKGROUND OF THE INVENTION

The damage caused by various insects, and in particular, wood boring and eating
15 insects, such as termites, is extensive around the world, totaling in the hundreds of
millions of dollars. Various methods and devices have been used in the past in an
attempt to alleviate or at least ameliorate the significant destruction caused by such
insects. For example, so called "baits stations" have been utilized in an attempt to attract
termites and thereby trap and/or destroy the termites that enter into such bait stations.
20 Bait stations are available in a variety of shapes, sizes and structures, but principally rely
upon the attractiveness of a cellulose product, such as paper or wood, to attract termite
populations. It is believed that the termites are attracted to the cellulose wood product
as a food source, however, prior art investigators have never conclusively determined
what particular aspect of the cellulose product used in such bait stations actually is the
25 attractive agent. Such cellulose products are typically treated with a toxin so that when
the termites consume the treated cellulose products, such termites are incapacitated
and/or killed. A significant problem in termite control, however, is the long period of
time required for termites to discover the food baits.

There is presently a long felt but unsolved need for a method and device that is
30 capable of attracting termites, and in particular, a method and device for attracting and
incapacitating and/or killing boring insects such as termites, beetles, etc. in a fashion
superior to prior art methods and devices.

Another aspect of the present invention involves the reduction of damage to
crops, particularly corn crops, caused by the corn root worm. The damages caused by

such insects is estimated to be over one billion dollars in the U.S. alone. Although pesticides have been used in the past to remedy such problems, they have been largely ineffective and have proven to cause environmental problems and to be fairly expensive. The present inventors were the first to discover that root worm larvae navigate to food sources by detecting carbon dioxide. There is therefore a long felt, but unsolved need for a method and formulation capable of attracting corn root worms to avoid the significant damage done by such insects every year.

SUMMARY OF THE INVENTION

The present invention is directed to a method and device for attracting certain insects, and in particular, boring insects such as termites and beetles. A separate aspect of the invention relates to a method and formulations for alleviating and/or reducing corn root worm damage. In one embodiment to the present invention, the method comprises the use of particular amounts of CO₂ as an attractant for such boring insects. The present invention includes not only the method for using particular novel formations, but the formulations themselves, as well as devices which incorporate such formulations for the trapping and/or destruction of boring insects.

With respect to the present novel formulations, such formulations generally have in common the ability to give off particular amounts of CO₂ found by the present inventors to be particularly attractive to boring insects such as termites. In one embodiment, the present formulation comprises the generation of CO₂ in a concentration of from between about 2 mmol/mol to about 50 mmol/mol, more particularly in amounts greater than about 2 mmol/mol and less than about 20 mmol/mol, and even more preferably between about 5 and about 10 mmol/mol. Preferred CO₂ concentrations are at least above ambient concentrations. Such CO₂ concentrations can be generated using one or more of a biological generation source, a chemical generation source and a mechanical generation source. For example, certain bacterial, fungal (e.g., yeast), algal and other microorganism formulations can be used that generate the above-referenced concentrations of CO₂ over a particular period of time. Alternatively, chemical reactions that generate CO₂ can be utilized to achieve such concentrations such as carbonate, calcium carbonate and various bicarbonate formulations as set forth and/or referred to herein. Finally, mechanical systems which incorporate the slow release of contained

sources of CO₂ can be utilized to achieve desired objectives of the present invention. Combinations of the biological, chemical and mechanical methods and devices are also within the scope of the present invention. The detailed description of such embodiments can be found in the detailed description of the preferred embodiments, below.

5 The novel method of the present invention comprises the generation of CO₂ in an amount within the above-specified ranges in order to attract boring insect populations. For example, such method comprises positioning an enclosure containing one or more of the above-referenced biological, chemical and/or mechanical sources of CO₂ in an area sought to be protected from boring insects such as termites. Various controls with
10 respect to CO₂ generation fall within the scope of the present invention, including temperature, light sensors, temporal adjustment mechanisms, etc., to achieve desired CO₂ emissions within appropriate concentration ranges at particular times of day and/or night, and/or at particular ambient temperatures at which insects may be most attracted to such sources, etc.

15 With respect to the device of the present invention, various forms and structures are contemplated including bait traps and stations similar to those commercially available. Still other embodiments, however, have a varied configuration as set forth in the figures.

 A separate aspect of the present invention involves the use of charred cellulose
20 material, and in particular charred wood, as an attractant for boring insects such as termites. While not being bound by theory, the present inventors believe that charred wood provides an easier target material for boring insects and thus, over evolutionary time, such boring insects have evolved a particular attraction to charred cellulose as a feeding stimulant. A further aspect of the present invention, therefore, includes the
25 particular novel compositions and formulations found in charred wood that attracts such boring insects and the use of such compounds in the above-described method, devices and formulations for attracting and extermination of undesired insects such as boring beetles, termites, etc.

 Also included within the scope of the present invention are the use of chemical
30 mimics of CO₂ to induce behavioral manipulation of any boring insect population, including all termite species. Such CO₂ mimics include, but are not limited to, haloalkanes and alkylcarbonates.

The various formulations of the present invention that comprise CO₂ or CO₂ mimics, may further be combined with sources of insecticide, sources of food, feeding stimulants, or other materials that arrest and/or stimulate termite movement or behavior. In addition, the use of CO₂ or CO₂ mimics, alone or in combination with other components, can be used to disrupt the orientation behavior of termites in a behavioral fashion, rather than as acting as a physiologically deleterious fumigant. Thus, CO₂ and CO₂ mimics can be used as co-attractants for termites along with other attractive materials that may have fundamentally different chemical compositions. The formulations of the present invention can be used to attract termites to termite traps, and further can be used to monitor the presence or abundance of particular termite species. Indeed, in one embodiment of the present invention manipulation of the amount of CO₂ generated can be adjusted to attract a particular species of termite, given the present inventors' appreciation and recognition that different CO₂ concentrations are more or less attractive to various species of termites. An extensive list of termite bait compounds that can be used in conjunction with the present invention to fashion appropriate formulations is shown in tables set forth below.

A separate aspect of the present invention relates to a method and formulation for ameliorating the damage caused by corn root worms. The present inventors were the first to discover that corn root worms are capable of navigating to food sources by detecting carbon dioxide emitted from roots. The present invention is directed to various formulations found effective in attracting such root worms in a manner that protects growing crops from destruction by such insects. In particular, the present inventors are the first to discover an inexpensive and readily available material that, if applied properly, can be used to vastly reduce the damage caused by corn root worms. In particular, the present inventors are first to discover that spent grain and distillers grain can be used by farmers as a readily available and inexpensive source of a CO₂ evolving agent. Farmers must apply such spent grain/distillers grain components into the soil during planting and/or cultivation (e.g., in temperate climates such as Colorado, from May - July) so that CO₂ is generated during a period of time that the corn root worm larvae are present. By plowing such material into the soil, CO₂ is evolved and corn root worm larvae are confused as to the source of CO₂ being generated, thus sparing the corn roots which would normally be the target for such root worms.

In a particularly preferred method of the present invention, rather than generally plowing spent grains/distillers grain materials into a field, such material is administered to the fields in strips in between or adjacent to corn rows, thus providing a source of CO₂ that attracts corn root worms away from growing corn plants. The present invention not only encompasses, therefore, the method of applying such materials at particular times during the growing season, but also to machinery used to preferably administer such material. Indeed, the present invention involves a new use for existing machinery used in planting and in fertilizer applications, such as a cone planter and starter fertilizer equipment, conventionally used for corn planting and fertilization. Such existing machines can be further modified to achieve the desired objective of the present invention so that sources of CO₂ evolving substances can be precisely contacted with the soil to achieve the corn root worm attractant objective.

Corn root worms can be attracted by use of biological, chemical and mechanical means, most preferably biological and chemical means as set forth herein as applicable to other boring insects, such as termites.

An obvious advantage of the present invention is that CO₂ is an inexpensive, environmentally-friendly compound that is readily available and can be generated in a number of ways.

These and other advantages and aspects of the present invention will be described in detail below and with reference to the experimental examples and figures.

BRIEF DESCRIPTION OF THE DRAWINGS

Fig. 1 illustrates how a typical cone planter can be modified in order to place formulations of the present invention a desired distance from a particular corn seed.

Fig. 2 illustrates how a starter fertilizer attachment on a corn planter can be utilized to properly place the formulations of the present invention within a desired distance from a corn seed.

Fig. 3 illustrates one embodiment of a jar trap for insects, including termites.

DETAILED DESCRIPTION OF THE PREFERRED EMBODIMENTS;

The present inventors incorporate by reference the following U.S. Patents in their entirety, such patents disclosing various compounds and formulations that are useful in conjunction with the present invention. U.S. Patent No. 5,338,551 to Lajoie; U.S. Patent
5 No. 5,342,630 to Jones; U.S. Patent No. 5,346,704 to Lajoie; U.S. Patent Nos. 5,389,386, 5,415,877, 5,424,270, 5,425,952, 5,432,146, 5,432,147, 5,432,148, 5,443,835 and 5,464,805 to Winston; U.S. Patent No. 5,468,715 to Joseph et al.; U.S. Patent Nos. 5,468,716, 5,496,568, 5,518,986, 5,518,987 and 5,583,089 to Winston.

One aspect of the present invention is directed to the alleviation of corn root
10 worm damage by providing a CO₂ evolving agent in a planted field so as to attract and/or otherwise confuse corn root worms, thus reducing the damage caused by such root worm to corn roots. Although biological, chemical and mechanical methods, as otherwise set forth herein can be used, biological and chemical formulations are particularly preferred. Indeed, the present inventors are first to appreciate the use of inexpensive and readily
15 available materials to accomplish the objective of reducing corn root worm damage done to corn crops in the United States and elsewhere in the world. Specifically, the present inventors have discovered that spent grain and/or distiller's grain can be used, easily obtainable from breweries and alcohol generation facilities, such materials being either generally plowed into fields at appropriate times during the planting, cultivation and/or
20 growing season, and/or precisely located in such fields to achieve desired attractant functions. Farmers typically plow organic materials into their soils in the fall, however, this practice means that CO₂ is long evolved and dissipated long before the springtime planting and cultivation periods. It is during the planting and cultivation periods that the corn root worm larvae is present and initiates destruction of corn roots. The present
25 invention thus entails the first appreciation and recognition that by contacting (e.g., plowing) particular biological material, such as spent grain/distiller's grain into a field (e.g., corn fields), at an appropriate time in the spring or early summer (or any other planting and/or cultivation period in more temperate climates) it is possible to ameliorate the destruction caused by corn root worms.

30 In addition to the above-referenced CO₂ evolving agents, charcoal, activated carbon and decolorizing carbon, all readily available in the commercial marketplace, also have behavior activities against insects and are useful as substrates that can form carbon

dioxide when they are placed in contact with soil. Moreover, corn cob grits can be used as an acceptable microbial substrate for the production of CO₂. This material is readily available, inexpensive and provides a long, slow release formulation for the production of CO₂ to accomplish the objectives of the present invention.

5 In a preferred embodiment, strips of biological and/or chemical CO₂ evolving material are contacted with fields between or adjacent to the rows of plants. This can be accomplished by using various existing machines such a cone planters or starter fertilizer equipment. Modifying such equipment to achieve the desired precise placement of CO₂ evolving materials is preferred and such modifications will be obvious to one of skill in
10 the art given the general teachings and guidance of the present invention. Various biological sources for CO₂ evolving agents include ground germinated corn, clean cracked corn, malted barley, any other malted grain, corn gluten feed, fungal organisms such as yeast, bacteria, such as *S. cerevisiae* (sour dough bread starter), algae, and various other microorganisms that exist in soil.

15 Various chemical CO₂ evolving agents can be used, such as those mentioned herein, preferably including carbonates, including inorganic carbonates such as calcium carbonate, bicarbonates and alkyl carbonates. Urea-based compounds can also be utilized. In addition, double or other multiple acting compounds such as double acting
20 baking powder can be utilized. It is within the scope of the present invention to combine the chemical and biological CO₂ evolving agents in various formulations. For example, spent grain, preferably in a dried form, can be mixed with appropriate amounts of carbonates and/or bicarbonates and/or urea to form appropriate compounds for attracting corn root worm larvae/insects.

25 Another aspect of the present invention involves the new use of dried spent grain and/or distiller's grain. Typically, spent grain and distiller's grain is provided in a "wet" composition. Such a form is not suitable for commercial sale for use as a CO₂ evolving agent since in such a "wet" and/or moist state, the material will rot and will evolve CO₂ prior to the time that it is administered to the soil. Thus, one aspect of the present invention involves the manufacture of dry spent grain/distiller's grain having a long shelf
30 life so that it can be sold and properly administered to fields so as to accomplish the CO₂ evolving objective of the present invention.

Various other co-attractants can be added to the present inventive formulations (e.g., pheromones, etc.) to further enhance the attractive features of the present formulations.

5 In preferred embodiments, the formulations of the present invention are produced in either a solid or liquid form. In a solid form, the present invention is preferably in granular form of a nature and size that facilitates administration of such granules through existing insecticide administering equipment used in conventional farming operations. These include, but are not limited to a noble meter and a Winter-Steiger meter. In addition, liquid forms of the various formulations are contemplated which are believed
10 to be easier to handle and to administer. For example, such liquids could be crop dusted and/or subject to chemigation, using center pivot irrigation systems. Moreover, the present invention can be in the form of a gel or slurry for particular applications.

It is further within the scope of the present invention to use other available sources of CO₂ generation such as dry ice or more concentrated forms of CO₂ agents.
15 Indeed, one aspect of the present invention involves a method for applying CO₂ evolving agents at a particular advantageous distance from roots of plants to attract various insects (e.g., corn root worms). The farther away a CO₂ agent is placed from a plant root, the stronger (e.g., concentrated) the CO₂ evolving agent can be. The goal is to attract desired larvae/insects without causing damage to plant roots and thus, the distance and
20 concentration parameters will vary depending upon the particular plant involved and the particular CO₂ evolving agent employed.

The inventors are also the first to appreciate the generation and use of a compound that is useful not only to alleviate corn root worm problems, but at the same time, provides advantageous fertilization to desired plants. By use of ammonium
25 bicarbonate, for example, not only is CO₂ generated which attracts corn root worm larvae, such compound also acts to provide needed nutrients and fertilizer to corn plants.

Another aspect of the present invention relates to the use of charred cellulose material, such as wood, to attract various insects, such as boring insects, and in particular, termites. The present inventors are the first to appreciate the use of charred
30 wood as a bait for termites, including the role of burned wood as a source of volatile and non-volatile attractants and as a source of feeding stimulants for termites. As with corn

root worms, in addition to charcoal, activated carbon decolorizing carbon and corn cob grits can be used as the attractant/CO₂ evolving agent.

Any form of burned or charred natural materials or artificial materials (e.g., plastic, inorganic materials (clay)) may be used, preferably burned cellulosic matrix/burned polymeric matrix. The pyrolysis products of burning are similar for such materials as wood, paper, cardboard, fabric, textiles, wool, silk, bone, hair, horn, claws, or any other natural products, and the pyrolysis products of artificial polymers mimic the pyrolysis products of natural materials in many instances.

Examples of behavioral manipulation of termite species include, but are not limited to, the following:

Use of charred wood, products of charred wood, or other burned materials: (a) to attract termites to traps for monitoring the presence or abundance of termite species; (b) to attract termites to sources of insecticides, insect growth regulators, or other toxic or physiologically active materials; (c) as feeding stimulants for termites, to induce them to feed on sources of insecticides, insect growth regulators, or other toxic or physiologically active materials; (d) to attract termites to sources of food, feeding stimulants, or other materials that arrest termite movement; (e) to disrupt the orientation behavior of termites behaviorally rather than acting as a physiologically deleterious fumigant; (f) as co-attractants for termites along with other attractive materials that may have fundamentally different chemistry; and (g) for the behavioral manipulation of any termite species, including use of such burned materials as attractants or feeding stimulants for termites.

Still other aspects of the present invention relate to the use of compounds that are chemically isolated from burned wood or other burned materials: (a) as attractants for termites; (b) as feeding stimulants for termites; and (c) for use in disrupting termite behavior in any way.

With respect to the aspect of the present invention involving the attraction and/or termination of termites, the herein described biological, chemical and mechanical means can be utilized. With respect to mechanical means, in a preferred embodiment, jars having appropriately sized holes therein are utilized within which are stored attractant material. As can be seen in Figure 3, the physical configuration of such jars can be greatly varied, however, a shorter, squatter configuration is particularly preferred.

Moreover, apertures in the jars are preferably spaced about the circumference of the jar, and more preferably, evenly spaced throughout the surface area of the jar's sides. An important aspect of the present invention is the total area of apertures with respect to the jar's surface. In a preferred embodiment, no more than about 10% of the surface area of the jar comprises apertures, and more preferably, less than about 5% of the surface area of the jar. In a particularly preferred embodiment, the limited access of termites to the interior of the jar is believed to be advantageous given that termites seek such relatively small openings, potentially due to the higher concentrations of CO₂ emitting from such orifices. The physical configuration of such bait traps is typically that of "jars", such jars constructed of any suitable material including plastic, glass, ceramic, metal, etc. In general, the larger the volume of the bait trap, the better. In a particular embodiment, the diameter of the bait jar used is about 90 mm, with a height of about 100 mm and has hole diameters of approximately 3 mm wherein at least about 50 holes are evenly distributed over the entire circumference of the jar.

Within such bait traps, the attractant material of the present invention is provided. Indeed, in one embodiment, the present invention comprises the addition of soil to bait traps as the attractant material. Soil, which may include sand, gravel, pebbles, dirt, as well as other constituents, is freely attainable and especially when used in conjunction with conventional bait traps having cellulose products therein, the addition of soil is found to provide impressive and unexpected attractant results.

With respect to chemical attractive agents for use in termite attraction, regulation and extermination, citric acid combined with sodium bicarbonate is particularly preferred, especially in a pelletized form. Indeed, "fizzies" have been found to be particularly advantageous as a termite control attractant when added to soil having a moisture content of at least about 10% and more preferably about 20% of moisture.

While the majority of the Detailed Description of the Present Invention has been directed to boring insects such as termites and corn root worms, it should be appreciated that the present invention has application with various other insects, including, but not limited to carpenter ants and carpenter bees. Indeed, as set forth in the figures, various devices can be produced in accordance with the particular identifying characteristics of an insect sought to be attracted. For example, a carpenter ant and a carpenter bee attractant/trapping device is set forth in the figures.

With respect to the production of appropriate amounts of CO₂, an amount over the ambient CO₂ concentrations is required. Typically, ambient CO₂ concentrations are around .05% and up to .1% in urban areas. Thus, CO₂ concentrations of at least about .2%, preferably between .5% and 1% by volume and more preferably at least about 1% by volume. In other embodiments, however, concentrations of between 2% and 50%, and even up to 100% of CO₂ by volume, may be useful, dependent upon the particular application of the present invention to a particular insect. At 100% CO₂ concentrations, CO₂ acts as a fumigant rather than an attractant. It will be appreciated, however, that at sufficient distances from a CO₂ source, the more concentrated CO₂ source may be desired to act as an attractant so that appropriate CO₂ concentrations in the particular area in the vicinity of an insect is achieved.

Other compounds can be added to the present formulations to achieve either attractant or destruction ability of the formulation. For example, various poisons can be mixed with the CO₂ bait traps of the present invention. Essentially, any insecticide or insect growth regulator can be used in conjunction with a CO₂ evolving source. Examples of such compounds include hexaflurone and hydramethylnon. As mentioned elsewhere, various pheromones can also be utilized for particular insect species sought to be attracted, such pheromones added with the formulations of the present invention.

In the use of the present invention to attract termites, suitable bait traps are positioned away from building structures or other wooden edifices sought to be protected. Depending upon the CO₂ attractant utilized, the devices should have an effective life of several weeks, preferably several months, and as much as a year or more.

The attractant compounds and formulations of the present invention are generally referred to herein as "attracticides".

Yet another aspect of the present invention involves the manufacture of building materials so as to make such materials less susceptible to termite damage. For example, conventional foam panels used in insulation materials emit carbon dioxide. The elimination of carbon dioxide in the manufacture of such foam materials, by, for example, use of other non-CO₂ containing gases, provides a method to produce termite resistant building and/or insulation materials. Further aspects of the present invention also include methods to seal existing structures that are prone to emit CO₂ concentrations in amounts found attractive to various boring insects. For example, creating substantially

air-tight seals around conventional CO₂ based foam products is effective in reducing the attractant quality of such materials to boring insects such as termites. Other aspects of the present invention include chemical abatement or reduction of CO₂ emitting insulation and building materials to avoid possible destruction by boring insects attracted to CO₂ emitting substances. CO₂ emitting concentrations should be reduced to below the dose found in soils so as to eliminate any source of CO₂ that may attract insects.

Preferred formulations of the present invention are in pelleted form to achieve slow release of CO₂ at the above-described concentrations.

The following examples are illustrative only of particular embodiments of the present invention.

Example 1 - (Formulation 1 in Jar Traps at 1 meter)

Composition of Formulation 1 (Dried Spent Brewer's Grain): Spent brewer's grain obtained from a local brewery was spread out on trays and allowed to air dry overnight. The dried spent brewer's grain was then added to soil that contained 20% moisture (12 g dried spent brewer's grain per 100 g moist soil).

Trap Design: Jar traps were constructed from 16 ounce polyethylene jars with plastic screw caps. Each jar was drilled with 36 evenly-spaced holes (3 mm diameter) to allow volatiles to diffuse out of the trap and to allow termites to enter. A cylindrical basket was constructed for each cup trap from plastic fencing to facilitate removing the trap from the soil. Baited traps were prepared by placing 300 g of Formulation 1 in a jar trap. Unbaited traps were filled with 300 g of soil (20% moisture). A disk of cardboard (8 cm diameter) was placed in the top of each trap (baited and unbaited), covered with a thin layer of soil, and the lid was then screwed onto the trap.

Field sites: Fence posts infested with termites (*Reticulitermes tibialis*) were used for field trapping experiments at three different ranches in Colorado (Fort Collins, Nunn, and Akron). Each infested fence post was used as a point source for an experiment. Six traps, three baited and three unbaited, were placed in the ground evenly around the fence post at a distance of 1 meter. The traps were placed in the ground at a depth of 20 to 25 cm and covered completely with soil. Traps were checked weekly for the presence of

5 termites. Traps were checked for feeding damage on the cardboard disks. Cardboard disks were taken back to the laboratory, where each piece was carefully washed and spread out to dry. The amount of cardboard eaten was determined by scanning the pieces with a desktop scanner and calculating the area by using a computer graphics program (Adobe Photoshop). The experiment was continued for six weeks at each location.

Results:

1. Traps baited with dried spent brewer's grain (Formulation 1) were discovered sooner by termites than unbaited traps (Graph 1).
- 10 2. Termites consumed more cardboard from baited traps than from unbaited traps (Graph 2).
3. Termites were found more often in the baited traps than the unbaited traps (data collected, but not shown here).

15 **Conclusion:**

This experiment demonstrated that dried spent brewer's grain mixed with moist soil is effective as a bait for termites.

GRAPH 1A

Baited Trap Discovery Time

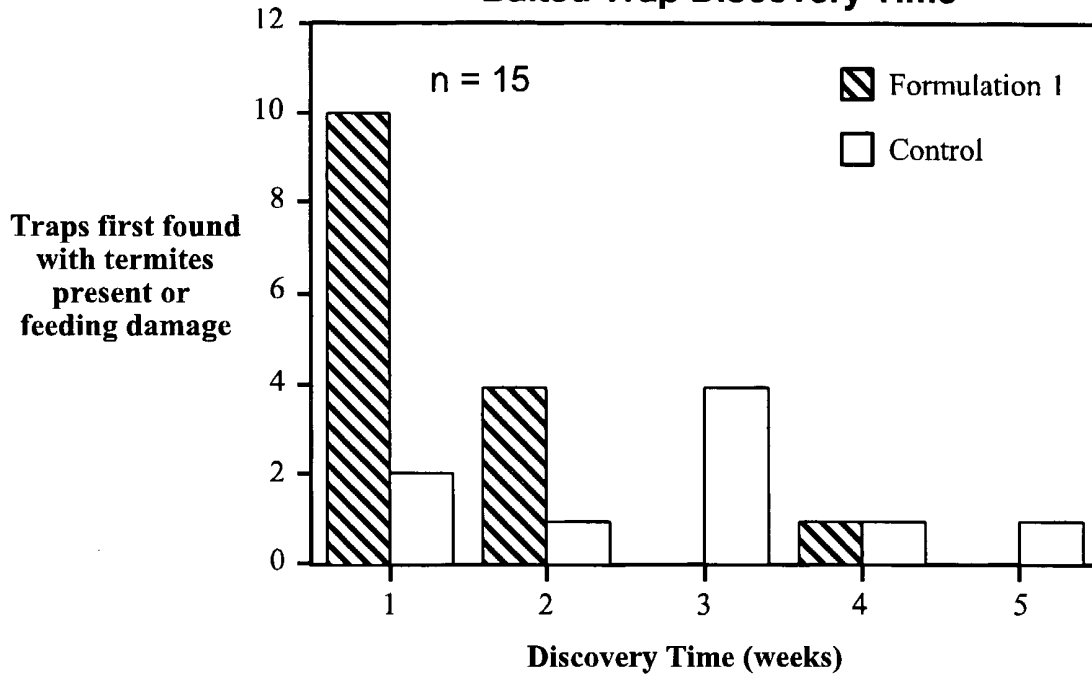

GRAPH 2A

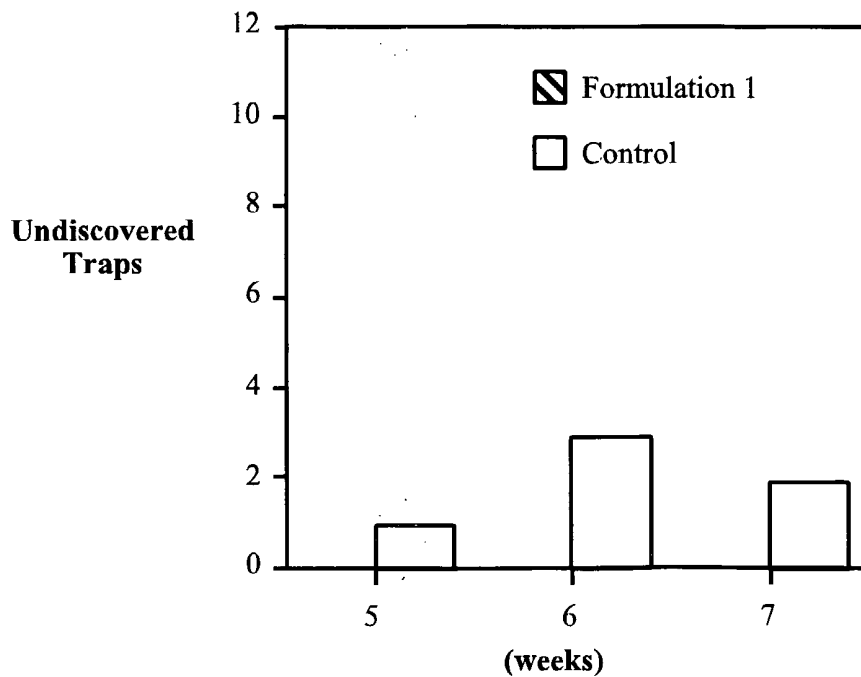

GRAPH 3A

1998 Termite Bait Field Tests

n = 15 (3 traps x 5 posts)

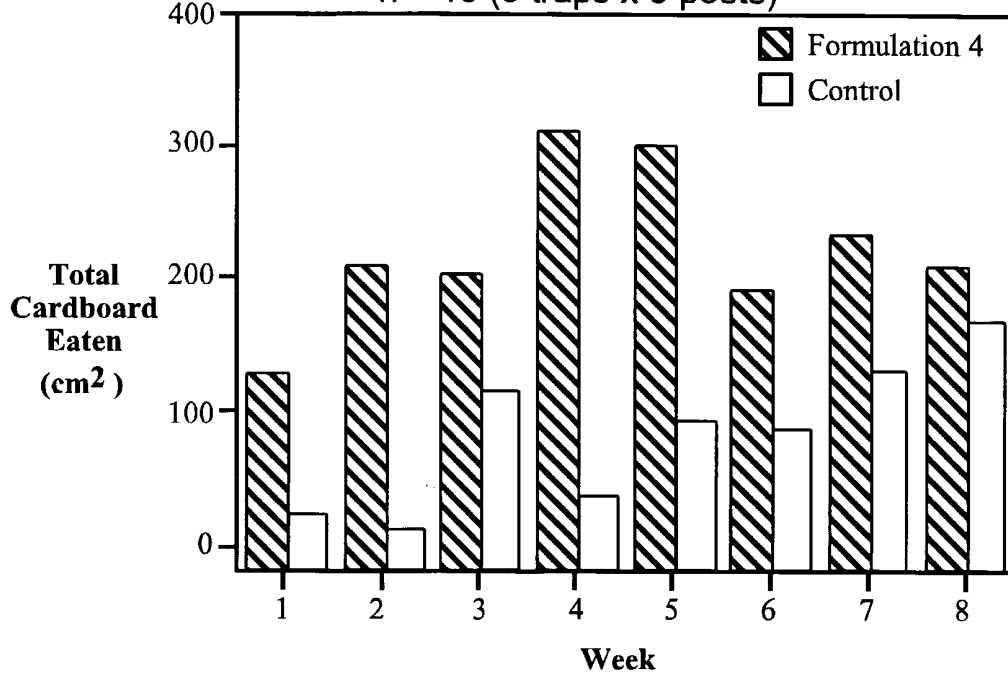

Example 2 - (Formulation 2 in Jar Traps at 1 meter)**Composition of Formulation 2 (Dried Ground Germinated Corn Seeds):**

Corn seeds were soaked in soapy water overnight, rinsed well and germinated in a covered plastic tub containing moist germination paper. After 3 days of germination, the germinating corn was ground to meal using a kitchen food processor, then spread out on trays and allowed to air dry overnight. Dried, ground, germinated corn seed (12 g per 100 g soil) was added to soil that contained 20% moisture.

Trap Design: Jar traps were constructed from 16 ounce polyethylene jars with plastic screw caps. Each jar was drilled with 36 evenly-spaced holes (3 mm diameter) to allow volatiles to diffuse out of the trap and to allow termites to enter. A cylindrical basket was constructed for each cup trap from plastic fencing to facilitate removing the trap from the soil. Baited traps were prepared by placing 300 g of Formulation 2 in a jar trap. Unbaited traps were filled with 300 g soil (20% moisture). A disk of cardboard (8 cm diameter) was placed in the top of each trap (baited and unbaited), covered with a thin layer of soil, and the lid was then screwed onto the trap.

Field sites: Fence posts infested with termites (*Reticulitermes tibialis*) were used for field trapping experiments at three different ranches in Colorado (Fort Collins, Nunn, and Akron). Each infested fence post was used as a point source for an experiment. Six traps, three baited and three unbaited, were placed in the ground evenly around the fence post at a distance of 1 meter. The traps were placed in the ground at a depth of 20 to 25 cm and covered completely with soil. Traps were checked weekly for the presence of termites. Traps were checked for feeding damage on the cardboard disks. Cardboard disks were taken back to the laboratory, where each piece was carefully washed and spread out to dry. The amount of cardboard eaten was determined by scanning the pieces with a desktop scanner and calculating the area by using a computer graphics program (Adobe Photoshop). The experiment was continued for six weeks at each location.

Results:

1. The discovery time was shorter for the baited traps than for the unbaited traps (Graph 2).

2. More cardboard was consumed by termites in the baited traps for weeks 1 through 5 (Graph 2).
3. Termites were found more often in the baited traps than the unbaited traps (data collected, but not shown here).

5

Conclusion:

This experiment demonstrated that dried ground germinated corn seeds mixed with moist soil is effective as a bait for termites.

GRAPH 2A

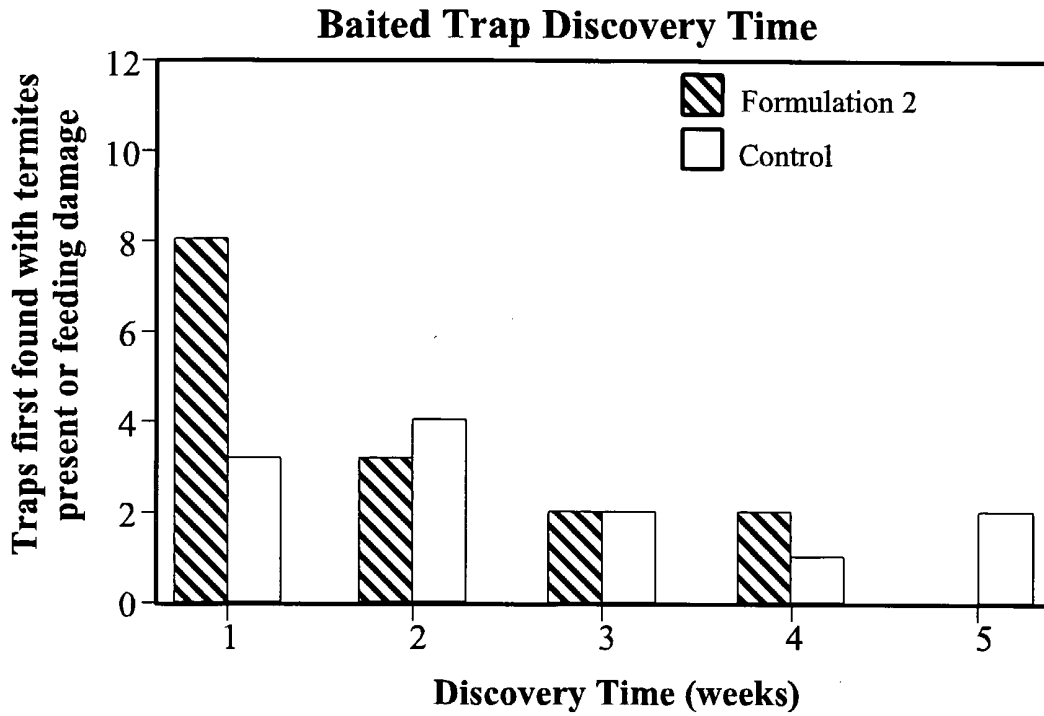

GRAPH 2B

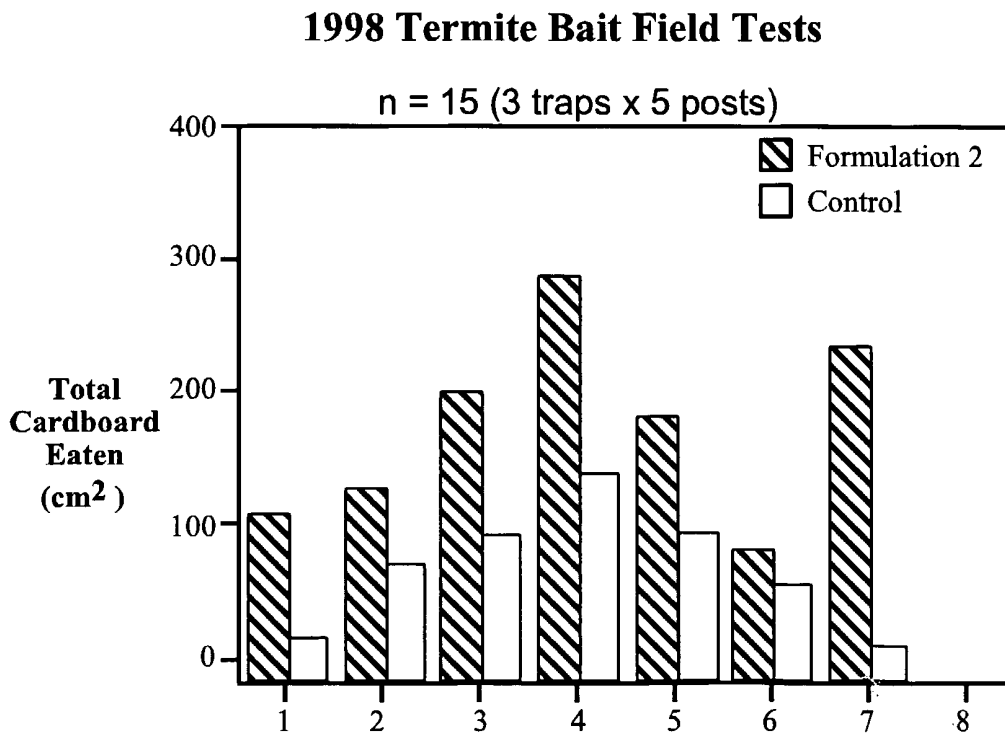

Example 3 - (Formulation 3 in Jar Traps at 1 meter)

Composition of Formulation 3 (Whole Dry Malted Barley): Whole dry malted barley was obtained from a local brewer's store. The whole dry malted barley was then added to soil that contained 20% moisture (12 g whole dry malted barley per 100 g moist soil).

Trap Design: Jar traps were constructed from 16 ounce polyethylene jars with plastic screw caps. Each jar was drilled with 36 evenly-spaced holes (3 mm diameter) to allow volatiles to diffuse out of the trap and to allow termites to enter. A cylindrical basket was constructed for each cup trap from plastic fencing to facilitate removing the trap from the soil. Baited traps were prepared by placing 300 g of Formulation 3 in a jar trap. Unbaited traps were filled with 300 g of soil (20% moisture). A disk of cardboard (8 cm diameter) was placed in the top of each trap (baited and unbaited), covered with a thin layer of soil, and the lid was then screwed onto the trap.

Field sites: Fence posts infested with termites (*Reticulitermes tibialis*) were used for field trapping experiments at three different ranches in Colorado (Fort Collins, Nunn, and Akron). Each infested fence post was used as a point source for an experiment. Six traps, three baited and three unbaited, were placed in the ground evenly around the fence post at a distance of 1 meter. The traps were placed in the ground at a depth of 20 to 25 cm and covered completely with soil. Traps were checked weekly for the presence of termites. Traps were checked for feeding damage on the cardboard disks. Cardboard disks were taken back to the laboratory, where each piece was carefully washed and spread out to dry. The amount of cardboard eaten was determined by scanning the pieces with a desktop scanner and calculating the area by using a computer graphics program (Adobe Photoshop). The experiment was continued for six weeks at each location.

Results:

1. Traps baited with whole malted barley (Formulation 3) were not discovered sooner by termites than unbaited traps (Graph 3, A & B). Within 3 weeks, 10 baited and 10 unbaited traps had been discovered by termites.

2. Termites did not consume more cardboard from baited traps than from unbaited traps (Graph 3, A & B).
3. Termites were not found more often in the baited traps than the unbaited traps (data collected, but not shown here).

5

Conclusion:

This experiment demonstrated that not all vegetable co-products are effective as baits for termites. In the specific context tested here, whole malted barley did not attract termites or enhance feeding.

10

GRAPH 3A

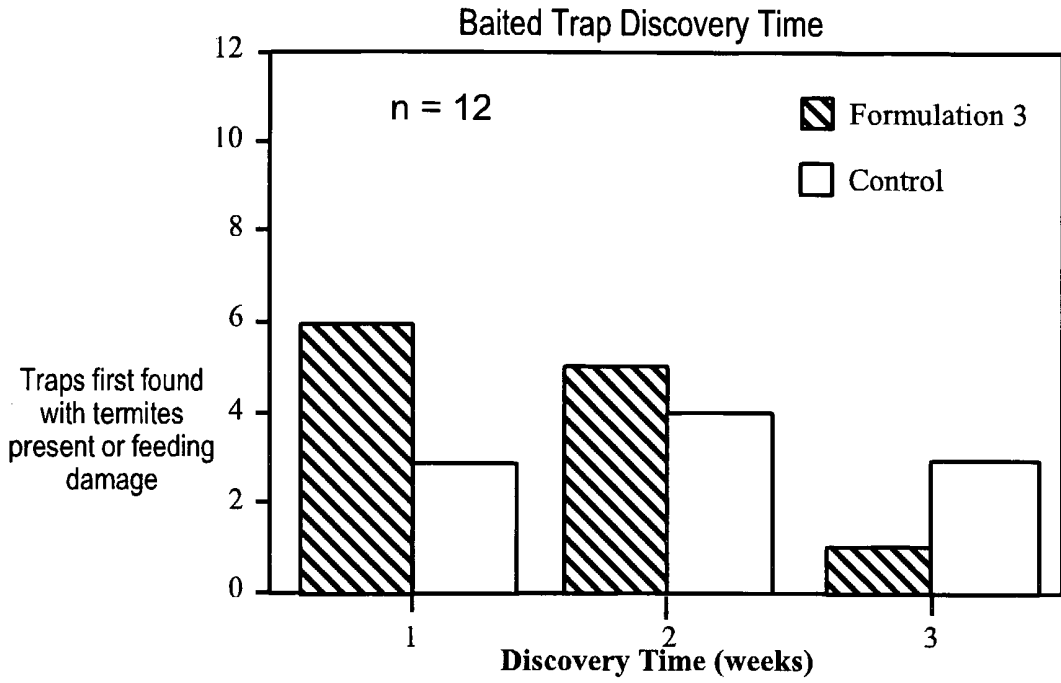

GRAPH 3B

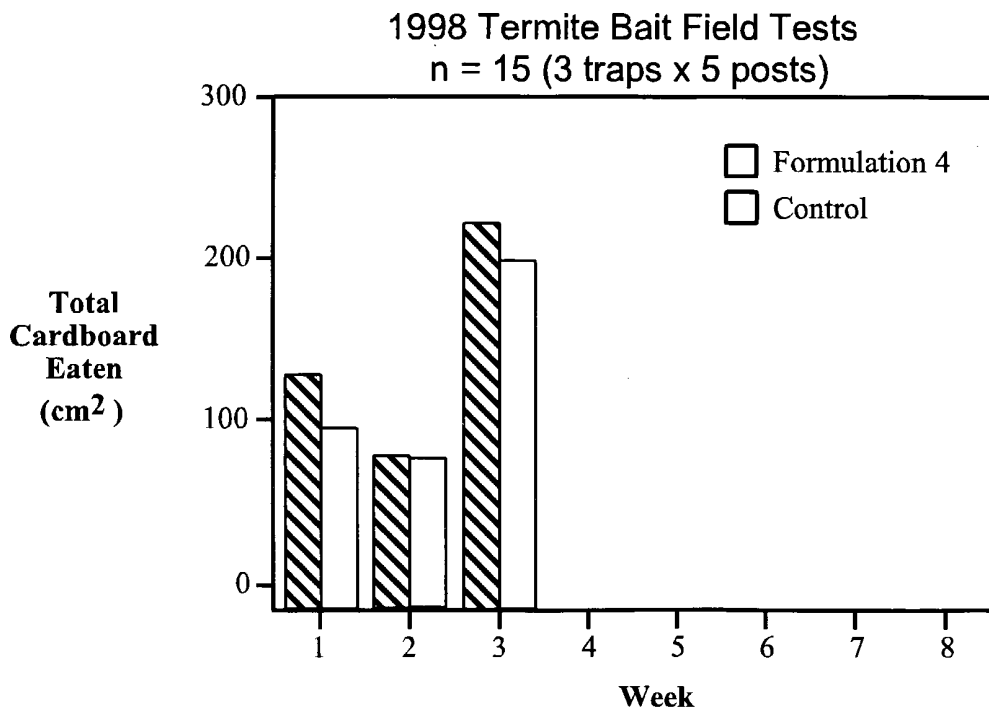

Example 4 - (Formulation 4 in Jar Traps at 1 meter)

Composition of Formulation 4 (Coated Sucrose Pellets): Sucrose pellets with a light wax coating were obtained from a local supplier (Sprinkle Decorations, Wilton Enterprises, Woodridge, IL). The sucrose pellets with a light wax coating were then added to soil that contained 20% moisture (12 g per 100 g moist soil).

Trap Design: Jar traps were constructed from 16 ounce polyethylene jars with plastic screw caps. Each jar was drilled with 36 evenly-spaced holes (3 mm diameter) to allow volatiles to diffuse out of the trap and to allow termites to enter. A cylindrical basket was constructed for each cup trap from plastic fencing to facilitate removing the trap from the soil. Baited traps were prepared by placing 300 g of Formulation 4 in a jar trap. Unbaited traps were filled with 300 g of soil (20% moisture). A disk of cardboard (8 cm diameter) was placed in the top of each trap (baited and unbaited), covered with a thin layer of soil, and the lid was then screwed onto the trap.

Field sites: Fence posts infested with termites (*Reticulitermes tibialis*) were used for field trapping experiments at three different ranches in Colorado (Fort Collins, Nunn, and Akron). Each infested fence post was used as a point source for an experiment. Six traps, three baited and three unbaited, were placed in the ground evenly around the fence post at a distance of 1 meter. The traps were placed in the ground at a depth of 20 to 25 cm and covered completely with soil. Traps were checked weekly for the presence of termites. Traps were checked for feeding damage on the cardboard disks. Cardboard disks were taken back to the laboratory, where each piece was carefully washed and spread out to dry. The amount of cardboard eaten was determined by scanning the pieces with a desktop scanner and calculating the area by using a computer graphics program (Adobe Photoshop). The experiment was continued for six weeks at each location.

Results:

1. Traps baited with coated sucrose pellets (Formulation 4) were not discovered sooner by termites than unbaited traps (Graph 4, A & B). Within 3 weeks, 10 baited and 10 unbaited traps had been discovered by termites.
- 5 2. Termites did not consume more cardboard from baited traps than from unbaited traps (Graph 4, A & B).
3. Termites were not found more often in the baited traps than the unbaited traps (data collected, but not shown here).

10 **Conclusion:**

This experiment demonstrated that not all carbohydrate sources are effective as baits for termites. In the specific context tested here, coated sucrose pellets did not attract termites or enhance feeding.

GRAPH 4A

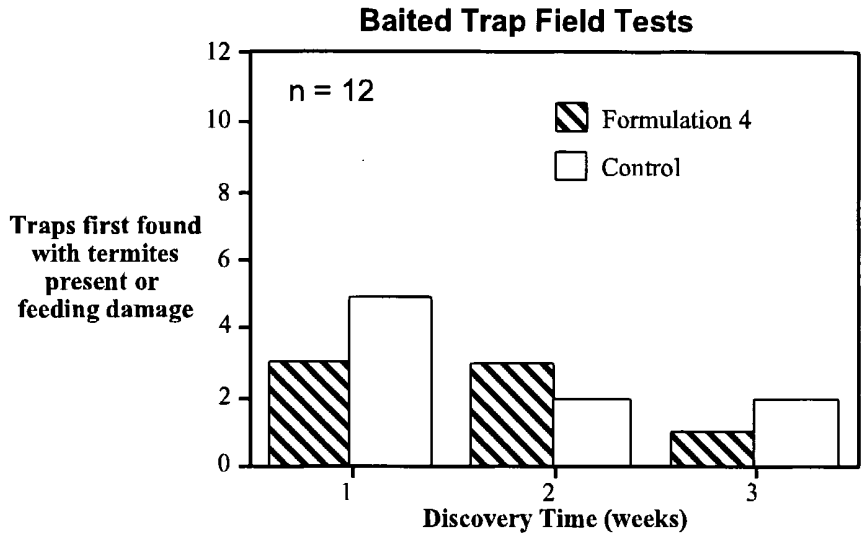

GRAPH 4B

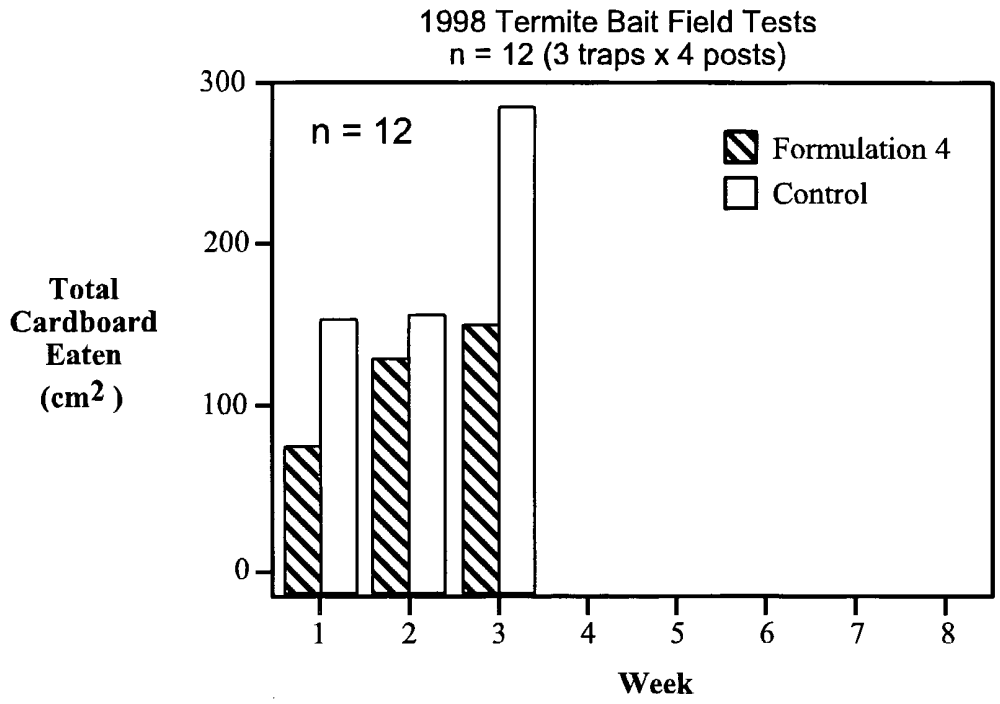

Example 5 - (Formulation 1 in Jar Traps at 2 meters)

Composition of Formulation 1 (Dried Spent Brewer's Grain): Spent brewer's grain obtained from a local brewery was spread out on trays and allowed to air dry overnight. The dried spent brewer's grain was then added to soil that
5 contained 20% moisture (12 g dried spent brewer's grain per 100 g moist soil).

Trap Design: Jar traps were constructed from 16 ounce polyethylene jars with plastic screw caps. Each jar was drilled with 36 evenly-spaced holes (3 mm diameter) to allow volatiles to diffuse out of the trap and to allow termites to enter. A
10 cylindrical basket was constructed for each cup trap from plastic fencing to facilitate removing the trap from the soil. Baited traps were prepared by placing 300 g of Formulation 1 in a jar trap. Unbaited traps were filled with 300 g of soil (20% moisture). A pre-weighed square of Ponderosa pine (4 x 4 x 0.5 cm) was soaked in water for 15 minutes and was placed in the top of each trap (baited and unbaited),
15 covered with a thin layer of soil, and the lid was then screwed onto the trap.

Field sites: Fence posts infested with termites (*Reticulitermes tibialis*) were used for field trapping experiments at three different ranches in Colorado (Fort Collins, Nunn, and Akron). Each infested fence post was used as a point source for
20 an experiment. Six traps, three baited and three unbaited, were placed in the ground evenly around the fence post at a distance of 2 meters. The traps were placed in the ground at a depth of 20 to 25 cm and covered completely with soil. Traps were checked weekly for the presence of termites. Traps were checked for feeding damage on the wood squares. Wood squares were taken back to the laboratory, washed with
25 water, and spread out to dry. The dried wood squares were weighed to determine the amount that had been eaten. The experiment was continued for six weeks at each location.

Results:

30

1. Traps baited with dried spent brewer's grain (Formulation 1) were discovered sooner by termites than unbaited traps (Graph 5, A, B & C).

2. Termites consumed more wood from baited traps than from unbaited traps (Graph 5, A, B & C).
3. Termites were found more often in the baited traps than the unbaited traps (Graph 5, A, B & C).

5

Conclusion:

This example demonstrated that dried spent brewer's grain mixed with moist soil is effective as a bait for termites, not only at 1 meter from the infested wood structure as in Example 1, but also at 2 meters from the infested wood structure. In addition, this example showed that thin squares of Ponderosa pine could be used to evaluate feeding, as an alternative to the cardboard disks used in Example 1.

10

GRAPH 5A

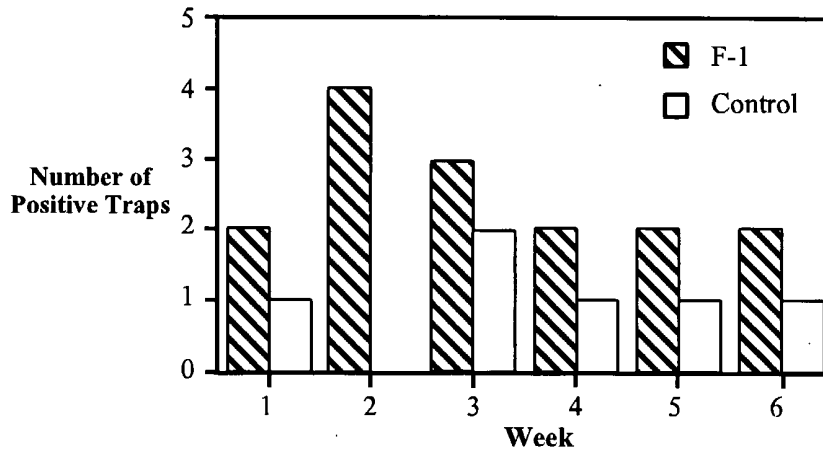

GRAPH 5B

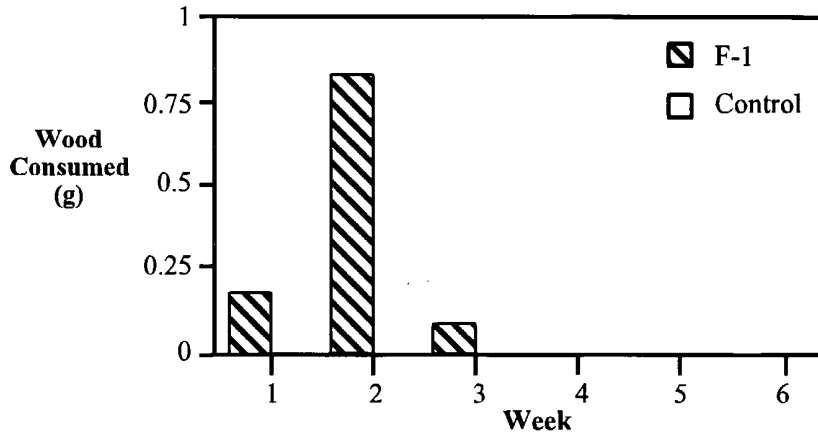

GRAPH 5C

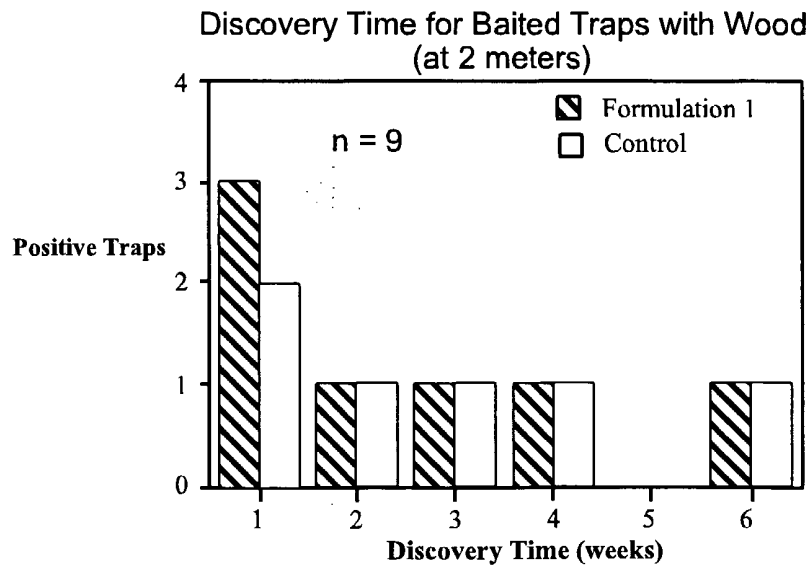

Example 6 - (Formulation 2 in Jar Traps at 2 meter)**Composition of Formulation 2 (Dried Ground Germinated Corn Seeds):**

Corn seeds were soaked in soapy water overnight, rinsed well and germinated in a covered plastic tub containing moist germination paper. After 3 days of germination, the germinating corn was ground to meal using a kitchen food processor, than spread out on trays and allowed to air dry overnight. Dried, ground, germinated corn seed (12 g per 100 g soil) was added to soil that contained 20% moisture.

Trap Design: Jar traps were constructed from 16 ounce polyethylene jars with plastic screw caps. Each jar was drilled with 36 evenly-spaced holes (3 mm diameter) to allow volatiles to diffuse out of the trap and to allow termites to enter. A cylindrical basket was constructed for each cup trap from plastic fencing to facilitate removing the trap from the soil. Baited traps were prepared by placing 300 g of Formulation 2 in a jar trap. Unbaited traps were filled with 300 g soil (20% moisture). A pre-weighed square of Ponderosa pine (4 x 4 x 0.5 cm) was soaked in water for 15 minutes and was placed in the top of each trap (baited and unbaited), covered with a thin layer of soil, and the lid was then screwed onto the trap.

Field sites: Fence posts infested with termites (*Reticulitermes tibialis*) were used for field trapping experiments at three different ranches in Colorado (Fort Collins, Nunn, and Akron). Each infested fence post was used as a point source for an experiment. Six traps, three baited and three unbaited, were placed in the ground evenly around the fence post at a distance of 2 meters. The traps were placed in the ground at a depth of 20 to 25 cm and covered completely with soil. Traps were checked weekly for the presence of termites. Traps were checked for feeding damage on the wood squares. Wood squares were taken back to the laboratory, washed with water, and spread out to dry. The dried wood squares were weighed to determine the amount that had been eaten. The experiment was continued for six weeks at each location.

30

Results:

1. The discovery time was shorter for the baited traps than for the unbaited traps (Graph 6).

2. More wood was consumed by termites in the unbaited traps than from the baited traps for weeks 1 and 2, but more was consumed from the baited traps in weeks 3 and 4 (Graph 6).
3. Termites were found more often in the baited traps than the unbaited traps
5 (Graph 6).

Conclusion:

This example demonstrated that dried ground germinated corn seeds mixed with moist soil is effective as a bait for termites, not only at 1 meter from the infested
10 wood structure as in Example 2, but also at 2 meters from the infested wood structure. In addition, this example showed that thin squares of Ponderosa pine could be used to evaluate feeding, as an alternative to the cardboard disks used in Example 2.

GRAPH 6A

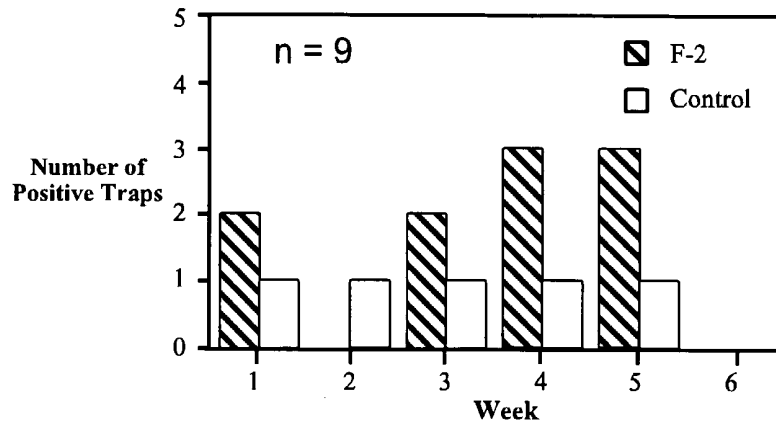

GRAPH 6B

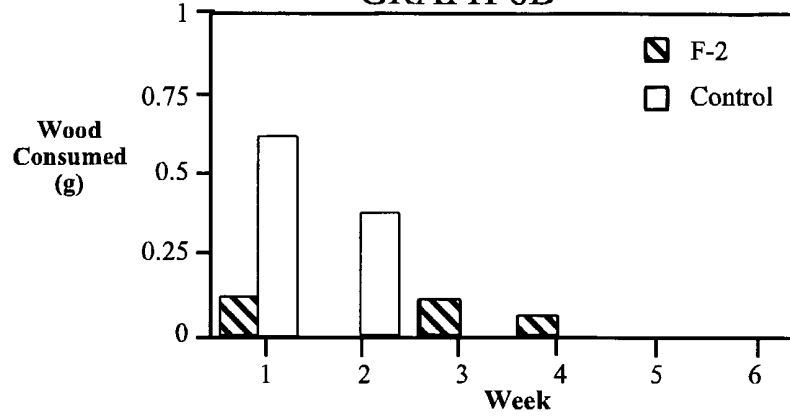

GRAPH 6C

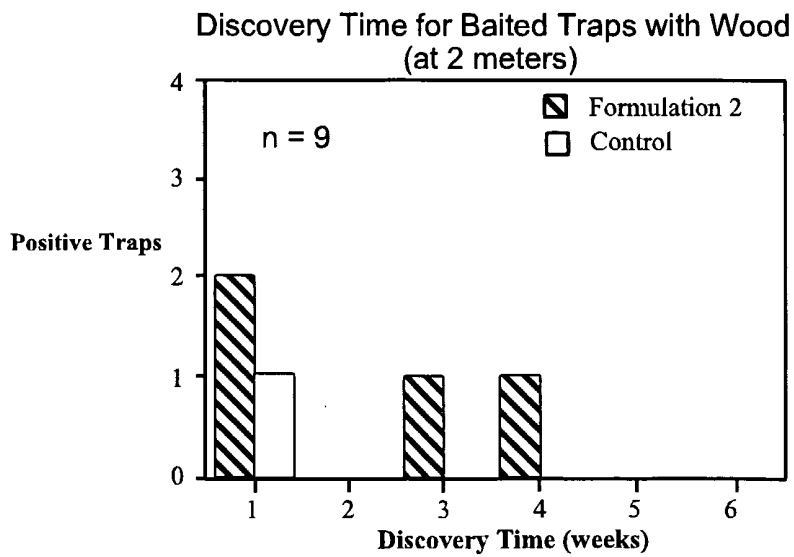

Example 7 - (Formulation 5 in Jar Traps at 2 meters)**Composition of Formulation 5 (Fizzies Instant Sparkling Drink Tablets):**

Effervescent tablets comprised of 50:50 citric acid:sodium bicarbonate were obtained from a local grocery store (Fizzies brand drink tablets, Premiere Innovations, Pacific Palisades, CA 90272). Two tablets (3 g each) were added to soil (300 g) that contained 20% moisture.

Trap Design: Jar traps were constructed from 16 ounce polyethylene jars with plastic screw caps. Each jar was drilled with 36 evenly-spaced holes (3 mm diameter) to allow volatiles to diffuse out of the trap and to allow termites to enter. A cylindrical basket was constructed for each cup trap from plastic fencing to facilitate removing the trap from the soil. Baited traps were prepared by placing 300 g of Formulation 5 in a jar trap. Control traps were filled only with 300 g soil (20% moisture). A square of Ponderosa pine (4 cm by 4 cm by 0.5 cm width) that had been pre-weighed was moistened by soaking it in water for 15 minutes, then placed in the top of each trap (baited and unbaited) just below the surface of the soil.

Field sites: Fence posts infested with termites (*Reticulitermes tibialis*) were used for field trapping experiments at three different ranches in Colorado (Fort Collins, Nunn, and Akron). Each infested fence post was used as a point source for an experiment. Six traps, three baited and three unbaited, were placed in the ground evenly around the fence post at a distance of 2 meters. The traps were placed in the ground at a depth of 20 to 25 cm and covered completely with soil. Traps were checked weekly for the presence of termites. Traps were checked for feeding damage on the wood squares. Wood squares were taken back to the laboratory, washed with water, and spread out to dry. The dried wood squares were weighed to determine the amount that had been eaten. The experiment was continued for six weeks at each location.

Results:

1. The discovery time was shorter for the baited traps than for the unbaited traps (Graph 7).

2. More wood was consumed by termites in the baited traps than from the unbaited traps (Graph 7).
3. Termites were found more often in the baited traps than the unbaited traps (Graph 7).

5

Conclusion:

This example demonstrated that sodium bicarbonate/citric acid tablets mixed with moist soil is effective as a bait for termites.

GRAPH 7A

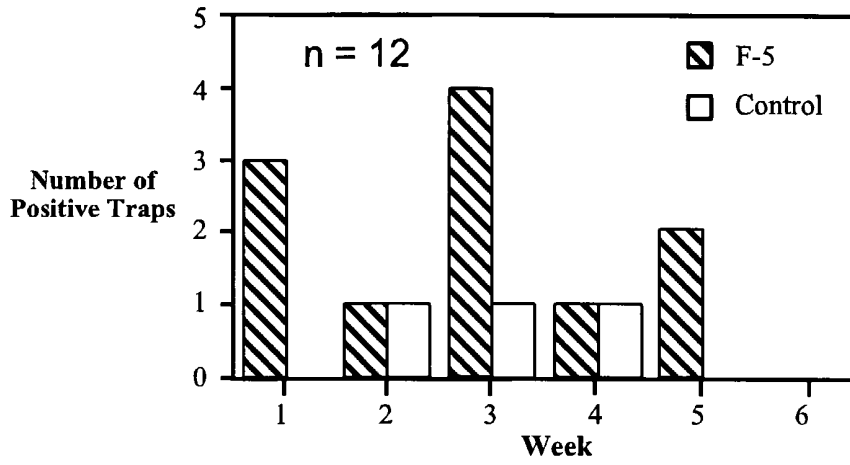

GRAPH 7B

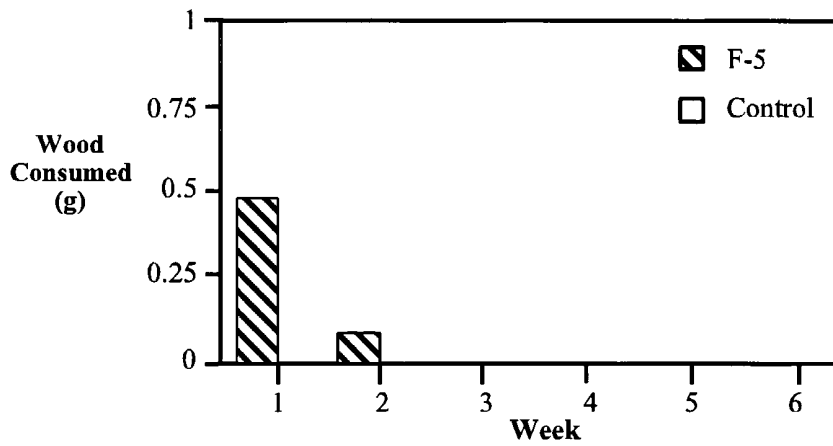

GRAPH 7C

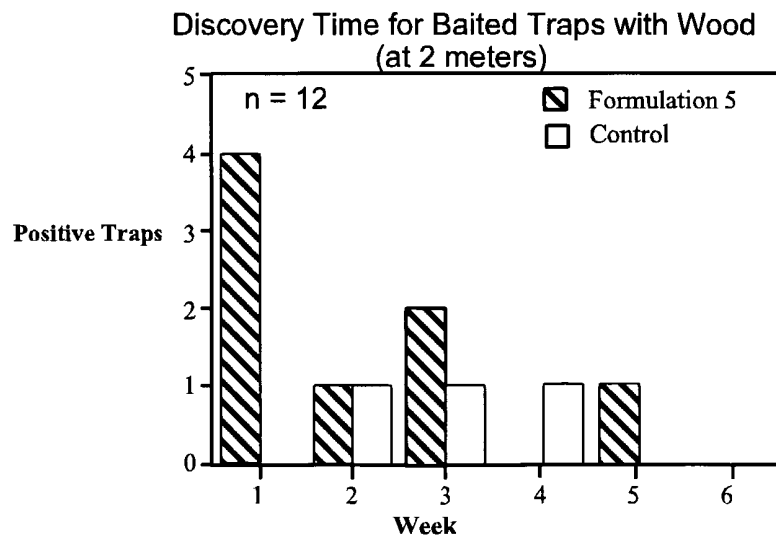

**Example 8 - (CO₂-generating Formulations tested in
Laboratory Behavioral Bioassays)**

Bioassay apparatus: The choice-test bioassay apparatus consisted of two traps, one filled with a CO₂-generating formulation mixed in soil and the other filled with soil alone. Traps were constructed from 1 ounce plastic nut cups with a 1 mm hole drilled in the top and three pin holes drilled at equal intervals around the cup (placed midway from top to bottom) to allow CO₂ to diffuse out. A triangular hole (4 mm high and wide) was cut on the top edge of each cup and a similar triangle was cut from the edge of the lid. With the lid in place and the holes lined up, a small opening was created to allow termites to enter the apparatus from the bottom. The two cups (1 treatment and 1 control) were placed at opposite ends of a plastic tub (Rubbermaid, 24 oz., 19 by 10.5 by 5.5 cm). Termites (15 workers) were collected from one of 20 recently field-collected colonies using a small paint brush and were placed in a plastic shell vial (4 ml) cap. The cap was inverted on a 1.5 cm circle of moist filter paper in the center of the plastic tub. The tub was placed on one shelf of a small wood shelf unit whose base is constructed of 10 cm thick foam rubber. After 15 minutes, the shell vial cap was gently tipped over, releasing the termites. A curtain was pulled in front of the shelves to provide dim lighting. After 24 hours, the tub was removed, each cup was gently disassembled and the termites counted. Termites were not reused in subsequent tests. All 12 formulations were tested using *Reticulitermes tibialis* (20 replicates) and 4 of the formulations were tested using *Reticulitermes virginicus* (10 replicates).

Preparation of Formulations: A CO₂-generating formulation was added to soil that contained 20% moisture. The amount of each formulation to be mixed with 100 g soil is listed below. For each experiment, one cup was filled with 25 g moist soil (20% water). The other cup was filled with formulation/soil mixture (25 g total). A circle of corrugated cardboard (3 cm diameter) was moistened with water, blotted lightly and placed on top of soil. The lid was put on and the cups were inverted.

Analysis of CO₂: A capillary tube (5.5 cm long, 0.5 mm diam) was inserted into the hole in the top of the inverted plastic cup. CO₂ was measured by taking a sample of the atmosphere within the soil using a 10 microliter syringe. The CO₂

concentration was determined using gas chromatography-mass spectrometry with selected ion monitoring (GC-MS-SIM) at m/e 44. The cup was used for a behavioral bioassay after the CO₂ concentration was determined to be adequate. Some formulations required 24-36 hours to generate enough CO₂.

5

Results:

Formulation 1: Dried Spent Grain (0.5 g per 25 g soil): Significantly more termites were recovered from the treated cups than the controls for both species of termites (Graph 8). The average CO₂ concentration at the start of the bioassay was 6.48 mmol per mol (Graph 8).

10

Formulation 2: Dried Ground Germinated Corn Seeds (0.5 g per 25 g soil): Significantly more termites were recovered from the treated cups than the controls for *Reticulitermes tibialis* (Graph 8). Slightly more termites were recovered from the treated cups than the controls in tests with *Reticulitermes virginicus*. The average CO₂ concentration at the start of the bioassay was 5.55 mmol per mol (Graph 8).

15

Formulation 3: Whole, malted barley (0.5 g per 25 g soil): Significantly more termites were recovered from the treated cups than the controls for *Reticulitermes tibialis* (Graph 8). Slightly more termites were recovered from the treated cups than the controls in tests with *Reticulitermes virginicus*. The average CO₂ concentration at the start of the bioassay was 3.7 mmol per mol (Graph 8).

20

Formulation 4: Sucrose pellets with a light wax coating (0.5 g per 25 g soil): Significantly more termites were recovered from the treated cups than the controls for *Reticulitermes tibialis* (Graph 8). The average CO₂ concentration at the start of the bioassay was 5.22 mmol per mol (Graph 8).

25

Formulation 5: Effervescent tablets (Fizzies brand drink tablets, 0.25 g per 25 g soil): There was no significant difference in the number of termites recovered from the treatment and the control for *Reticulitermes tibialis* (Graph 8). The average CO₂ concentration at the start of the bioassay was 38.19 mmol per mol (Graph 8).

30

Formulation 6: Yeast Granules (made from corn flour, corn syrup, NYPD nutrient broth and baker's yeast, 0.5 g granules per 25 g soil): Significantly more termites were recovered from the treated cups than the controls for *Reticulitermes tibialis* (Graph 8). There was no significant difference in the number of termites recovered

from the treatment and the control for *Reticulitermes virginicus*. The average CO₂ concentration at the start of the bioassay was 5.60 mmol per mol (Graph 8).

5 **Formulation 7:** Dry Baker's Yeast (0.25 g granules per 25 g soil): Significantly more termites were recovered from the treated cups than the controls for *Reticulitermes tibialis* (Graph 8). The average CO₂ concentration at the start of the bioassay was 5.93 mmol per mol (Graph 8).

10 **Formulation 8:** Potassium Bicarbonate, Fine Granules (0.25 g granules per 25 g soil): Significantly more termites were recovered from the treated cups than the controls for *Reticulitermes tibialis* (Graph 8). The average CO₂ concentration at the start of the bioassay was 16.71 mmol per mol (Graph 8).

Formulation 9: Clean Cracked Corn (sold as livestock feed) (0.5 g granules per 25 g soil): Significantly more termites were recovered from the treated cups than the controls for *Reticulitermes tibialis* (Graph 8). The average CO₂ concentration at the start of the bioassay was 4.21 mmol per mol (Graph 8).

15 **Formulation 10:** Ground Dry Corn Seed (0.5 g granules per 25 g soil): Significantly more termites were recovered from the treated cups than the controls for *Reticulitermes tibialis*. The average CO₂ concentration at the start of the bioassay was 4.48 mmol per mol (Graph 8).

20 **Formulation 11:** Ground Malted Barley (0.5 g granules per 25 g soil): There was no significant difference in the number of termites recovered from the treatment and the control for *Reticulitermes tibialis* (Graph 8). The average CO₂ concentration at the start of the bioassay was 8.31 mmol per mol (Graph 8).

25 **Formulation 12:** Baking Powder/Corn Syrup Granules (0.5 g granules per 25 g soil): These granules were made from double-acting baking powder and corn syrup. Significantly more termites were recovered from the treated cups than the controls for *Reticulitermes tibialis* (Graph 8). The average CO₂ concentration at the start of the bioassay was 18.86 mmol per mol (Graph 8).

Conclusions:

30 1. In laboratory behavioral bioassays, *Reticulitermes tibialis* exhibited attraction to formulations 1, 2, 3, 4, 6, 7, 8, 9, 10 and 12 (Graph 8). In this particular context, *Reticulitermes tibialis* were not attracted to formulation 5 or 11.

2. In laboratory bioassays, *Reticulitermes virginicus* exhibited attraction to formulations 1, and 2 (Graph 8). In this particular context, *Reticulitermes virginicus* were not attracted to formulation 3 or 4.
 3. All the formulations contained elevated CO₂ by comparison with controls (Graph 8).
- 5

GRAPH 8A

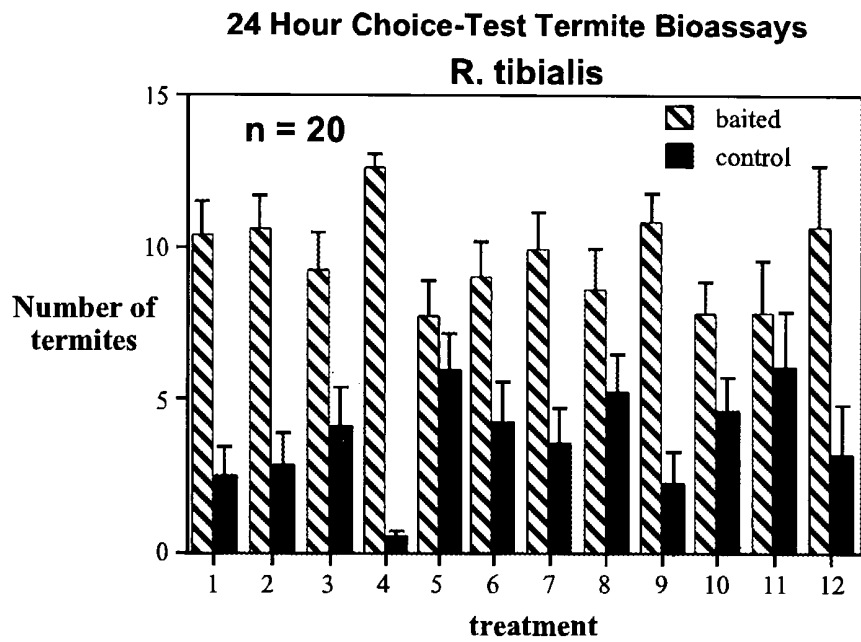

GRAPH 8B

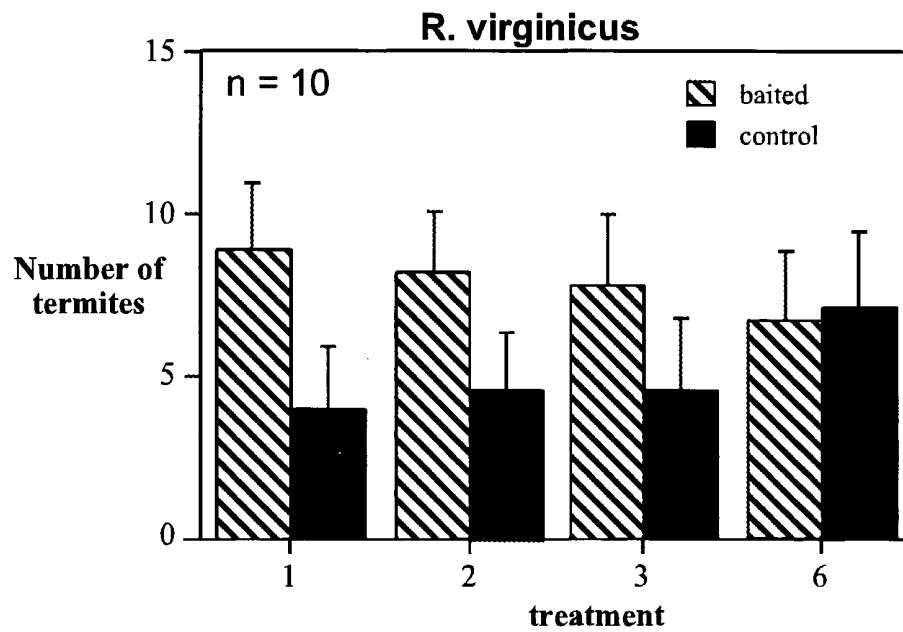

GRAPH 8C
CO₂ Concentrations for 24 Hour Choice-Test Bioassays

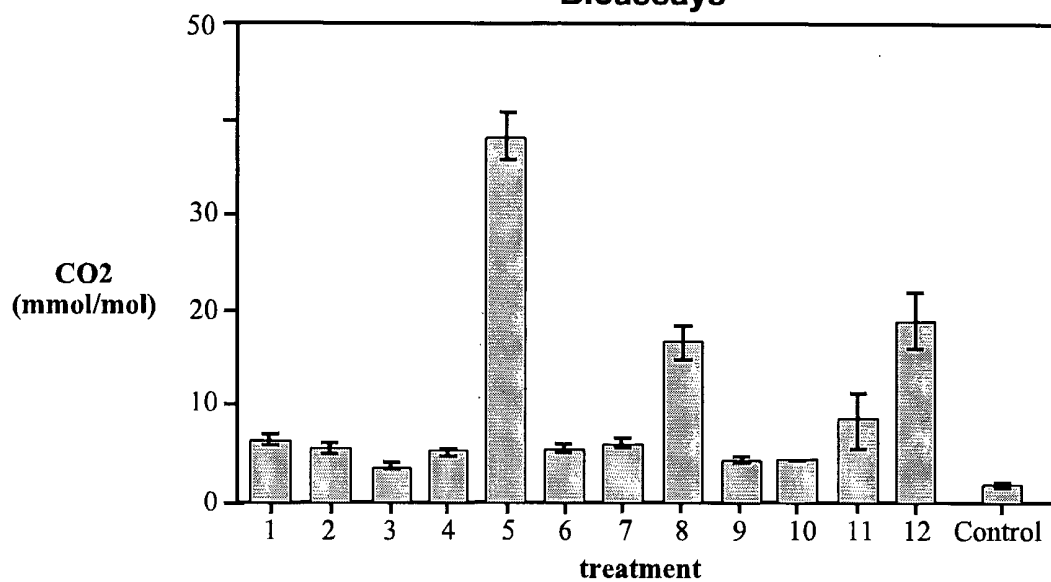

Example 9 - (Formulation 1 in Dow Sentricon Bait Stations)

Composition of Formulation 1: Dried spent brewer's grain was obtained from a local brewery, and was spread out and allowed to air dry overnight. Dried spent grain (12 g per 100 g soil) was added to soil that contained 20% moisture.

5

Trap Design: Dow Sentricon Termite Bait Stations were used for field experiments. A perforated plastic sleeve of our own design was inserted into each Dow Sentricon Termite Bait Stations to allow CO₂ generating formulations to be used in them. The insert consisted of a tube (21 cm long, 3.5 cm diameter) constructed of clear acetate film. Holes were punched 3 cm apart in the tube (0.5 cm) to allow CO₂ to diffuse out and to allow termites to enter the trap. Baited traps were prepared by placing a strip of Dow Sentricon wood (18 cm by 2.5 cm by 0.5 cm) inside a perforated plastic sleeve, then adding 150 g of Formulation 1. This thinner strip of Dow wood was necessary in order to allow Formulation 1 to fill the plastic sleeve properly. The filled sleeve was then inserted into a Dow Sentricon Termite Bait Station. Control traps contained perforated plastic sleeves filled with a strip of Dow Sentricon Wood and 150 g soil (20% moisture).

Field sites: Fence posts infested with termites (*Reticulitermes tibialis*) were used for field trapping experiments at three different ranches in Colorado (Fort Collins, Nunn, and Akron). Each infested fence post was used as a point source for an experiment. Six traps were placed in the ground evenly around each infested fence post at a distance of 1 meter:

1. Two baited traps, containing bait plus soil, with 1 strip of Dow wood (18 x 2.5 x 0.5 cm)
2. Two unbaited traps, containing soil only, with 1 strip of Dow wood (18 x 2.5 x 0.5 cm)
3. Two standard Dow Sentricon Stations, with 2 strips of Dow wood (18 x 2.5 x 1 cm)

The traps were placed in the ground so that only the cover was exposed. Traps were checked weekly for the presence of termites by lifting the insert out of the trap for examination. The experiment was continued for 6 weeks. At the end of the experiment all wood strips were evaluated for feeding damage.

Results:

1. Termites were present in the baited traps for all 6 weeks of the experiment (example 9, page 2).
2. Termites were present in the soil-only control traps during week 1, 4, and 6 (example 9, page 2).
3. Termites were not present in any of the Dow control traps during the entire 6 weeks (example 9, page 2).
4. Feeding on the wood strips was heavier in the baited traps and in the soil-only control traps than in the unmodified Dow Sentricon Bait Stations (data collected, but not shown).

Conclusion: This experiment demonstrated that the modified Dow Sentricon Bait Stations containing Formulation 1 (dried spent brewer's grain) were discovered sooner and frequented more often by termites than the unmodified Dow Sentricon Bait Stations.

GRAPH 9

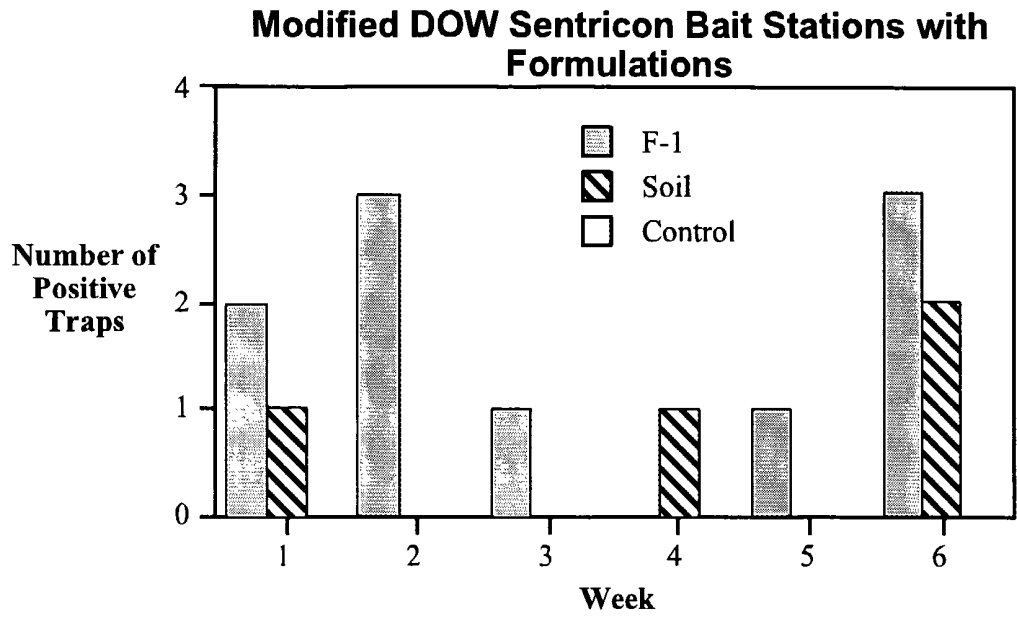

Example 10 - (Formulation 2 in Dow Sentricon Bait Stations)

Composition of Formulation 2: Corn seeds were soaked in soapy water overnight, rinsed well and germinated in a covered plastic tub containing moist germination paper. After 3 days of germination, the germinating corn was ground to meal using a kitchen food processor, then spread out on trays and allowed to air dry overnight. Dried ground germinated corn seed (12 g per 100 g soil) was added to soil that contained 20% moisture.

Trap Design: Dow Sentricon Termite Bait Stations were used for field experiments. A perforated plastic sleeve of our own design was inserted into each Dow Sentricon Termite Bait Stations to allow CO₂ generating formulations to be used in them. The sleeve consisted of a tube (21 cm long, 3.5 cm diameter) constructed of clear acetate film. Holes were punched 3 cm apart in the tube (0.5 cm) to allow CO₂ to diffuse out and to allow termites to enter the trap. Baited 70 traps were prepared by placing a strip of Dow Sentricon Wood (18 cm by 2.5 cm by 0.5 cm) inside a perforated plastic sleeve, then adding 150 g of Formulation 2. This thinner strip of Dow Sentricon Wood was necessary in order to allow Formulation 2 to fill the plastic sleeve properly. The filled sleeve was then inserted into a Dow Sentricon Termite Bait Station. Control traps contained perforated plastic sleeves filled with a strip of Dow Sentricon Wood and 150 g soil (20% moisture).

Field sites: Fence posts infested with termites (*Reticulitermes tibialis*) were used for field trapping experiments at three different ranches in Colorado (Fort Collins, Nunn, and Akron). Each infested fence post was used as a point source for an experiment. Six traps were placed in the ground evenly around each infested fence post at a distance of 1 meter:

1. Two baited traps, containing bait plus soil, with 1 strip of Dow wood (18 x 2.5 x 0.5 cm)
2. Two unbaited traps, containing soil only, with 1 strip of Dow wood (18 x 2.5 x 0.5 cm)
3. Two standard Dow Sentricon Stations, with 2 strips of Dow wood (18 x 2.5 x 1 cm)

The traps were placed in the ground so that only the cover was exposed. Traps were checked weekly for the presence of termites and for feeding damage by lifting the insert out of the trap for examination. The experiment was continued for 6 weeks.

5

Results:

1. Termites were present in the baited traps for weeks 1 and 2 of the experiment (Graph 10).
2. Termites were present in the soil-only control traps during week 3 (Graph 10).
- 10 3. Termites were present in the Dow control traps during weeks 2 and 5 (Graph 10).

Conclusion:

This experiment demonstrated that the modified Dow Sentricon Bait Stations containing Formulation 2 (dried ground germinated corn seed) did not attract more termites than the unmodified Dow Sentricon Bait Stations, implying that the trap design used in Example 2 may be necessary in order for Formulation 2 to increase attraction of termites.

20

GRAPH 10

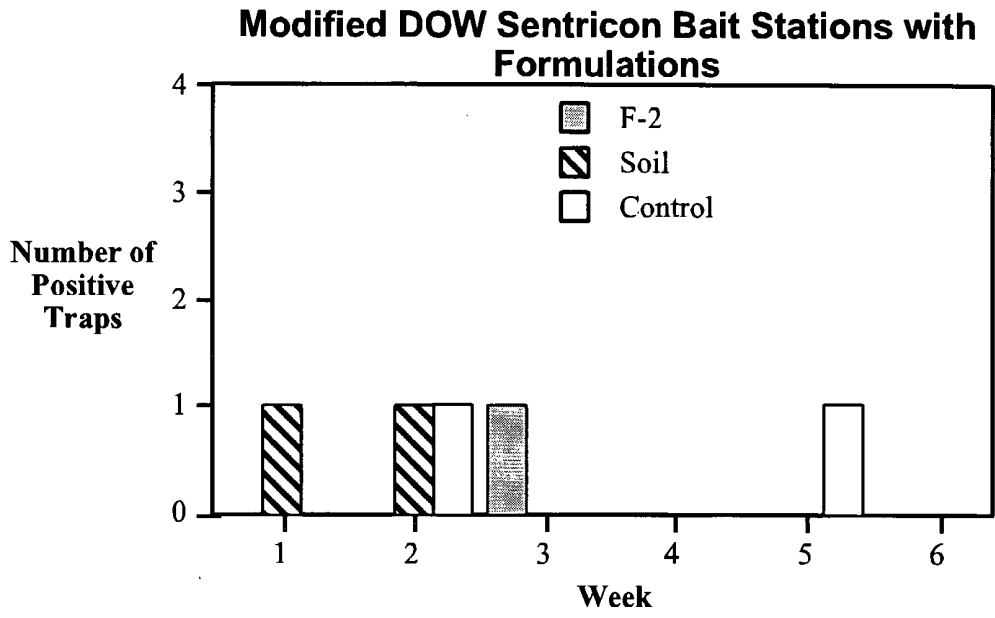

Example 11 - (Formulation 4 in Dow Sentricon Bait Stations)

Composition of Formulation 4: Sucrose pellets with a light wax coating were obtained from a local supplier (Sprinkle Decorations, Wilton Enterprises, Woodridge, IL). The sucrose pellets with a light wax coating were then added to soil
5 that contained 20% moisture (12 g per 100 g moist soil).

Trap Design: Dow Sentricon Termite Bait Stations were used for field experiments. A perforated plastic sleeve of our own design was inserted into each Dow Sentricon Termite Bait Stations to allow CO₂ generating formulations to be used
10 in them. The sleeve consisted of a tube (21 cm long, 3.5 cm diameter) constructed of clear acetate film. Holes were punched 3 cm apart in the tube (0.5 cm) to allow CO₂ to diffuse out and to allow termites to enter the trap. Baited traps were prepared by placing a strip of Dow Sentricon Wood (18 cm by 2.5 cm by 0.5 cm) inside a perforated plastic sleeve, then adding 150 g of Formulation 4. This thinner strip of
15 Dow Sentricon Wood was necessary in order to allow Formulation 4 to fill the plastic sleeve properly. The filled sleeve was then inserted into a Dow Sentricon Termite Bait Station. Control traps contained perforated plastic sleeves filled with a strip of Dow Sentricon Wood and 150 g soil (20% moisture).

Field sites: Fence posts infested with termites (*Reticulitermes tibialis*) were
20 used for field trapping experiments at two ranches in Colorado (Fort Collins and Nunn). Each infested fence post was used as a point source for an experiment. Six traps were placed in the ground evenly around each infested fence post at a distance of 1 meter:

- 25 1. Two baited traps, containing bait plus soil, with 1 strip of Dow wood (18 x 2.5 x 0.5 cm)
2. Two unbaited traps, containing soil only, with 1 strip of Dow wood (18 x 2.5 x 0.5 cm)
3. Two standard Dow Sentricon Stations, with 2 strips of Dow wood (18
30 x 2.5 x 1 cm)

The traps were placed in the ground so that only the cover was exposed. Traps were checked weekly for the presence of termites and for feeding damage by lifting the insert out of the trap for examination. The experiment was continued for 6 weeks.

5

Results:

1. Termites were present in the baited traps for weeks 1 through 4 of the experiment (Graph 11).
2. Termites were present in the soil-only control traps during all 6 weeks of the experiment (Graph 11).
3. Termites were present in the Dow control traps during weeks 1 and 2 (Graph 11).

10

Conclusion:

Traps containing Formulation 4 were initially more attractive than the soil-only control traps or the Dow control traps. However, soil-only control traps were the most attractive traps for the last weeks of the experiment.

15

GRAPH 11

Modified DOW Sentricon Bait Stations with Formulations

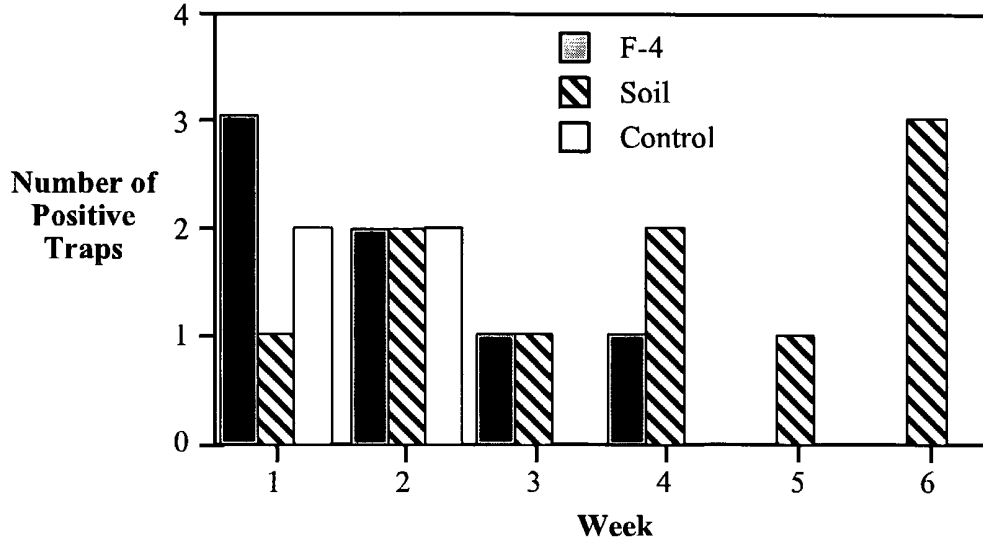

Example 12 - (CO₂-Dose Response in Behavioral Bioassays)

Behavioral bioassay apparatus: The choice-test bioassay apparatus was constructed from a glass T-tube (5 mm inside diameter, 5 mm stem, with each branch 4.5 cm long). Each branch of the 'T' was bent downward (2.5 cm from the junction of the 'T') at a 45° angle to form a pitfall trap. A 5 mm NMR cap (cat. no. 100-0050, Drummond Scientific, Broomall, PA) with a 1 mm pinhole in it was firmly pushed over the end of each bent branch. A 25 cm length of Teflon tubing (0.8 mm inside diameter) was inserted 3 mm into the hole in each NMR cap and the other end of the tubing was connected to a 35 ml polyethylene syringe (cat. no. 106-0490, Sherwood Medical, St. Louis, MO). The two 35-ml syringes were connected to a syringe pump which was adjusted to provide an airflow of 1 ml per min into each choice arm of the bioassay apparatus.

Mixtures of CO₂ and ambient air were tested to determine the termite response to a range of CO₂ concentrations. A 35-ml syringe was rinsed with distilled water and partially filled (5 ml) with ambient air. Different amounts of 100% CO₂ were obtained with a smaller glass syringe from a tank and injected into the 35-ml syringe. Ambient air was then drawn into the 35-ml syringe to fill it and mix the gases by turbulence as the syringe was loaded. A 2nd 35-ml polyethylene syringe was filled with ambient air for a control. Measurements with GC-MS-SIM confirmed that the CO₂ concentrations reached equilibrium after 15 min. The CO₂ concentration of the syringes was determined by using GC-MS-SIM analysis (see below) before each bioassay. Bioassays were conducted with both *Reticulitermes tibialis* and *Reticulitermes flavipes* for 1, 2, 5, 10, 20, 50 and 500 mmol per mol concentrations of CO₂ and with *Reticulitermes virginicus* for 5, 10, 20, and 50 mmol per mol.

Procedure: For bioassays, termite workers were collected from plastic tubs by using a camel's hair brush and were placed into a holding container constructed from a 3 cm length of Teflon tubing (8 mm inside diameter). The container was plugged at one end with a NMR cap with two holes (1 mm) drilled in the bottom. A second NMR cap with a 4 mm hole was inserted backwards into the other end of the Teflon tube. The end of the NMR cap cap was sealed with a small square of cellophane held in place with a plastic tube (a piece of plastic soda straw) that fit

snugly over the open end. Termites (5 workers) were placed in the container and the top was sealed. The container was placed horizontally and left undisturbed for 20 min. The T-tube apparatus was assembled and clamped horizontally on top of a block of foam rubber (12 by 12 cm) with a wire bent into a U-shape. The syringe pump was turned on, and after 3 min of pumping, the cellophane seal was removed from the holding container and the entrance to the holding container was gently connected to the central arm of the T-tube, allowing termites to crawl out and enter the apparatus. Bioassays were conducted for 15 min, after which the number of termites in each pitfall was recorded.

CO₂ measurements: Gas chromatography-mass spectrometry in selected ion monitoring mode (GC-MS-SIM) at m/e 44 was used to determine CO₂ concentrations. A Hewlett-Packard Series II 5890 gas chromatograph interfaced with a Hewlett-Packard 5971 mass selective detector was used with a methyl silicone capillary column (30 m x 0.32 mm inside diameter, RSL-150, Alltech, Deerfield, IL). A 10-mmmol/mol mixture of CO₂ (a 300-ml glass bottle into which 3 ml of CO₂ was injected) was used as a standard to calculate the CO₂ concentrations of the unknown samples.

Results:

1. *Reticulitermes tibialis* was attracted to 2, 5, and 10 mmol per mol CO₂. *R. tibialis* demonstrated the best attraction to 5 mmol per mol CO₂ (example 12, page 3).
2. *Reticulitermes flavipes* was attracted to 5, 10 and 20 mmol per mol CO₂. *R. flavipes* was most attracted to 10 mmol per mol (example 12, page 3).
3. *Reticulitermes virginicus* was attracted to 5, 10, 20 and 50 mmol per mol CO₂. *R. virginicus* demonstrated best attraction to 5 mmol per mol CO₂ (example 12, page 4).

Conclusions:

These laboratory bioassays demonstrated for the first time that termites are attracted to carbon dioxide. We have confirmed this attraction for 3 termite species, including *R. tibialis*, *R. flavipes* and *R. virginicus*.

GRAPH 12A

R. flavipes

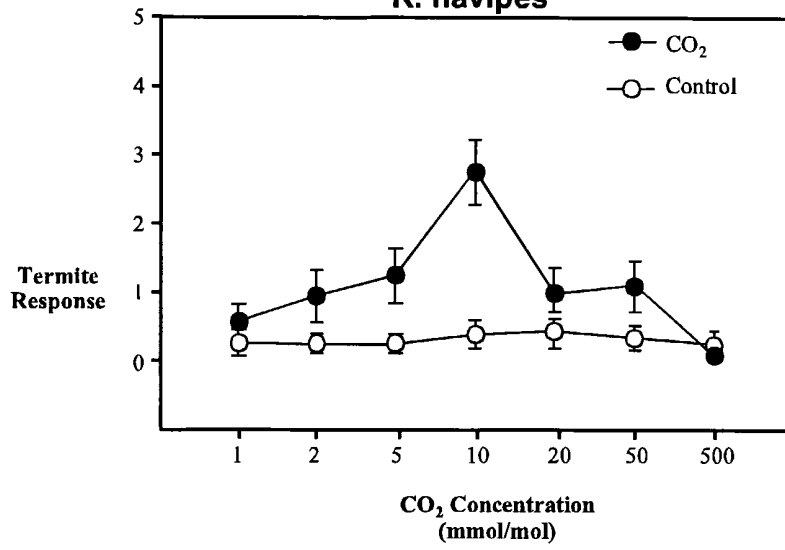

GRAPH 12B

R. tibialis

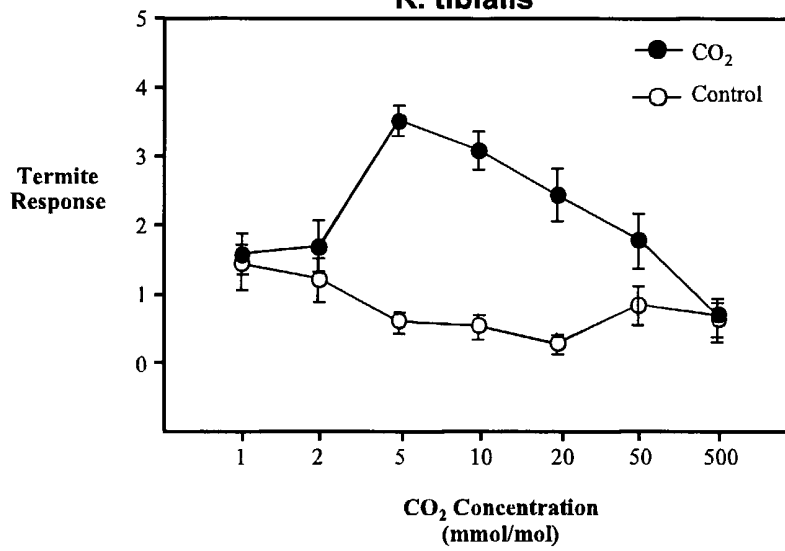

GRAPH 12C

R. virginicus

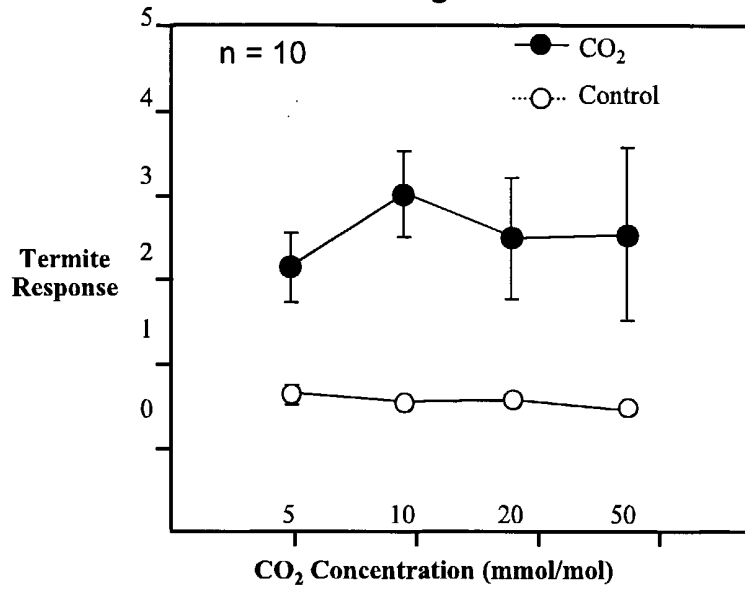

GRAPH 12D

First Response

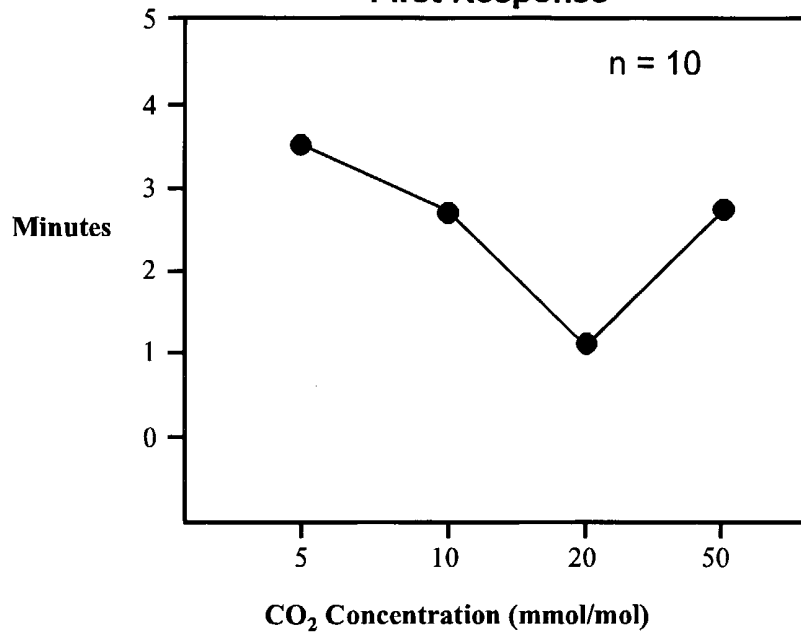

Example 13 – (Charred Wood in Dow Sentricon Bait Stations in Field Tests)

Treated (Charred) Wood: The wood strips (18 x 2.5 x 1 cm) were removed from new Dow Sentricon Bait Stations, and the surfaces were charred using a laboratory torch (propane and oxygen) with a three inch outer flame cone and one inch inner flame cone. The strips of wood were held in the flame and removed just prior to the point of ignition. All surfaces of the Dow Sentricon Wood strips were charred except for the top 3 cm of the wood strips. Prior to placing the strips in traps in the field, the strips were moistened by soaking in water for several minutes.

Trap design: We tested the attraction of termites to charred wood in field experiments during the summer of 1998. Standard Dow Sentricon Termite Bait Stations were used for field experiments.

Field sites: Fence posts infested with termites (*Reticulitermes tibialis*) were used for field trapping experiments at two ranches in Colorado (Fort Collins and Akron). Each infested fence post was used as a point source for an experiment. Six traps were placed in the soil evenly around a wood structure at a distance of 1 meter. For each experiment three of the traps contained 2 charred wood strips and three of the traps (controls) contained 2 uncharred wood strips. Traps were checked weekly for the presence of termites and feeding damage on the wood, for a period of 7 weeks.

Results:

1. Termites were present in baited traps for weeks 3 through 7 of the experiment.
2. No termites were found in any of the Dow control traps during the entire experiment.
3. Considerable termite feeding was observed on the charred Dow Sentricon Wood strips. The feeding damage was restricted to the charred portions of the strips, and did not occur on the uncharred region at the tops of the strips (data collected, but not shown).

Conclusion: This experiment demonstrates that charred Dow Sentricon Wood is more attractive to termites than the standard uncharred Dow Sentricon Wood, and that the charred wood acts as a feeding stimulant to termites.

Example 14 – (Charred Wood in Laboratory Soil Tub Bioassays)

Treated (Charred) Wood: A strip of Dow Wood (18 x 2.5 x 1 cm) was removed from a new Dow Sentricon Bait Station and cut into two pieces (9 x 2.5 x 1 cm). The surfaces of one piece were charred using a laboratory torch (propane and oxygen) with a three inch outer flame cone and one inch inner flame cone. The strip of wood was held in the flame and removed just prior to the point of ignition. All surfaces of the charred Dow Sentricon Wood strip were charred except for the top 1 cm of the wood strips. Prior to placing the strips in the bioassay device, the strips were moistened in separate water baths for several minutes. Charred and uncharred pieces of Ponderosa pine (2 x 4 x 7.5 cm) were tested in the same way.

Side-by-Side Choice Test Bioassay: A plastic tub (15 x 10 x 30 cm) long was filled with 6 lbs. of soil (20% moisture by weight). This amount of soil allowed for a level of soil 2.5 cm from the top of the tub. Two pieces of wood, one charred and one uncharred, were placed at one end of the tub, 5 cm from the end of the tub and 3 cm apart. The wood pieces were set upright and inserted into the soil nearly touching the bottom of the tub, resulting in a thin layer of soil between each piece of wood and the bottom of the tub, and with the upper 4 cm of each wood piece extending above the surface of the soil. One hundred termites were held in a petri dish for one hour in the closed assay apparatus in order to become acclimated to their new environment. The lid was removed after one hour and the termites were released into the soil at the end of the tub opposite the wood bait. The lid was replaced on the tub, and the tub was placed in a dimly lighted area of the lab for one week. After one week the tub was inspected for termite activity near each piece of wood. After two weeks the tub was taken apart and the wood was cleaned and inspected for feeding damage.

Results:

1. For the Dow wood, termites were observed feeding on the charred Dow Wood, and were not observed feeding on the uncharred Dow Wood.
2. Examination of the charred and uncharred Dow Wood at the end of the experiment indicated that most of the feeding had occurred on the charred Dow Wood (Graph 14).

3. Insects that had fed on the charred Dow Wood had black material inside the hindgut clearly visible through the abdomen, confirming that they fed on the burnt wood.
4. For the Ponderosa pine, termites were never observed feeding on the charred Ponderosa pine, and fed only on the uncharred Ponderosa pine.
5. Examination of the charred and uncharred Ponderosa pine at the end of the experiment indicated that all of the feeding had occurred on the uncharred Ponderosa pine (Graph 14).

10 **Conclusion:**

This experiment demonstrates that charred Dow Sentricon Wood is more attractive to termites than the standard uncharred Dow Sentricon Wood, and that the charred wood acts as a feeding stimulant to termites. Charred Ponderosa pine is apparently repellent to termites, and does not elicit feeding by the termites.

GRAPH 14

| | area eaten square mm | | |
|------------------|-------------------------|-------|--------------|
| | Mean | SE | Replications |
| Charred Dow Wood | 345.67 | 26.82 | 6 |
| Control Dow Wood | 25.00 | 8.02 | 6 |
| Charred Pine | 0.00 | 0.00 | 6 |
| Control Pine | 116.67 | 34.44 | 6 |

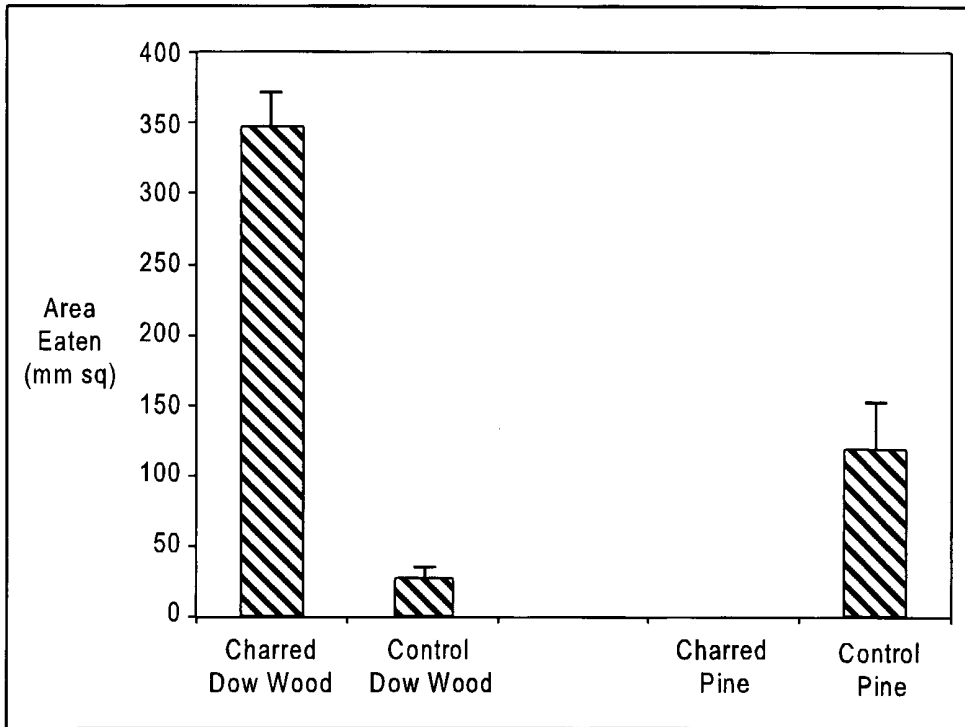

**Example 15 – (Wood Impregnated with Spent
Grain Extract in Lab Bioassays)**

Wood Impregnated with Aqueous Extract of Formulation 1: A plastic bowl with a snap-fit lid (Rubbermaid, 6 cup size) was filled with 24 ounces of water and 24 ounces of Formulation 1 (dried spent brewer's grain). This was mixed well and several pieces of Dow Wood (9 x 2.5 x 1 cm) were added to the bowl. The bowl was covered with the snap-fit lid and heated in a microwave oven for 2 minutes, which brought the liquid to a boil. The bowl was removed from the microwave oven, the contents of the bowl were stirred, the snap-fit lid was replaced on the bowl (with 4 small pin holes in lid for breathing), and the covered bowl was allowed to stand for 3 days. After 3 days, the pieces of wood were removed, rinsed sparingly with water to remove physical debris, and placed on paper towels to dry for 2 days. The extract-impregnated pieces of wood were moistened before placement in the bioassay.

End-to-End Choice Test Bioassay: A rectangular plastic tub (15 x 10 x 30 cm) was evenly partitioned into three separate sections, with two partitions made from the cut ends of another tub hot melt glued into the main tub. The partitions were drilled with fourteen 1/8 inch holes such that the holes were all below the soil surface and evenly arranged top-to-bottom and side-to-side. The tub was filled with 6 lbs. of soil (20% moisture by weight), evenly in the three sections. This amount of soil allowed for a level of soil 2.5 cm from the top of the tub. Two pieces of wood, one treated and one untreated, were placed at opposite ends of the tub, 0.5 cm from the end of the tub and 10 cm from the partition. The treated and untreated wood pieces were set upright, one at each end of the tub, and inserted into the soil nearly touching the bottom of the tub, resulting in a thin layer of soil between each piece of wood and the bottom of the tub, and with the upper 4 cm of each wood piece extending above the surface of the soil. One hundred termites were held in a petri dish for one hour in the closed assay apparatus in order to become acclimated to their new environment. The lid was removed after one hour and the termites were released into the soil at the center of the tub. The lid was replaced on the tub, and the tub was placed in a dimly lighted area of the lab for one week. After one week the tub was inspected for termite activity near each piece of wood. After two weeks the tub was taken apart and the wood was cleaned and inspected for feeding damage.

Results:

1. Termites were concentrated near the Dow wood impregnated with Formulation 1 (dried spent brewer's grain), and were not observed near the Dow wood piece that was untreated (Graph 15).
- 5 2. Extensive feeding damage by termites was observed on the Dow wood impregnated with Formulation 1 (dried spent brewer's grain), but no feeding damage was observed on the Dow wood piece that was untreated (Graph 15).

GRAPH 15

area eaten
square mm

| | Mean | SE | Replications |
|------------------|---------|------|--------------|
| Treated Dow Wood | 1304.50 | 0.00 | 1 |
| Control Dow Wood | 0.00 | 0.00 | 1 |

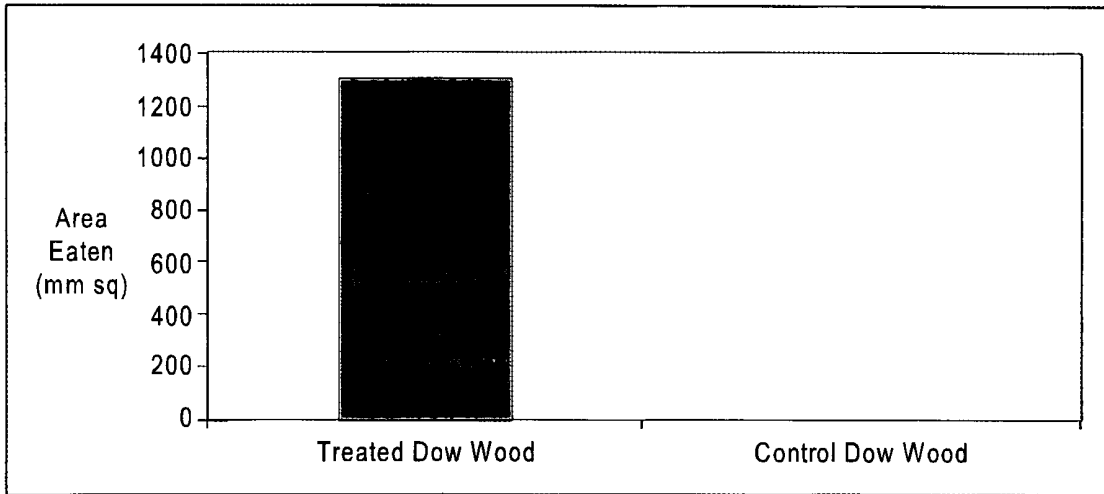

(zero)

area eaten
square mm
Mean SE Replications

| | | | |
|------------------|----|------|---|
| Treated Dow Wood | 98 | 0.00 | 1 |
| Middle | 29 | 0.00 | 1 |
| Control Dow Wood | 6 | 0.00 | 1 |

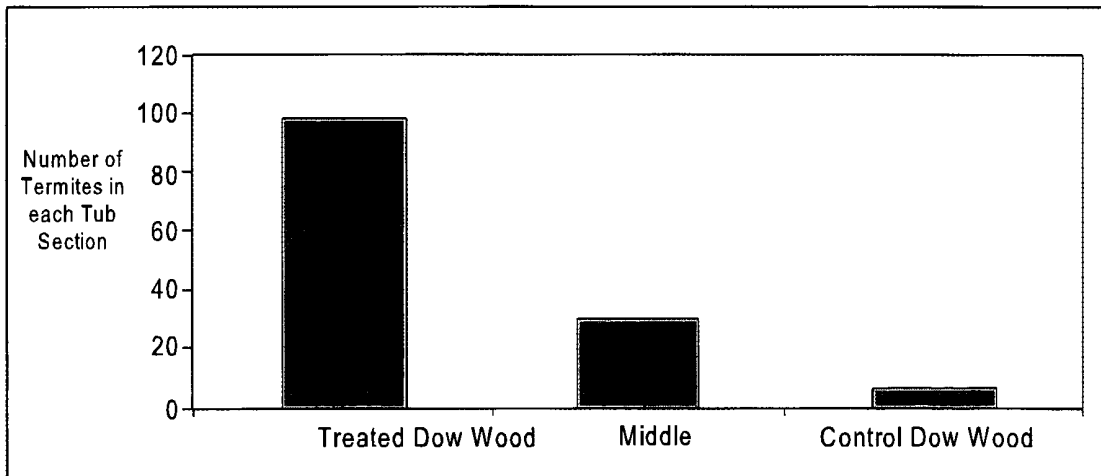

Example No. 16

We showed in a laboratory behavioral bioassay that the termite *Reticulitermes tibialis* is attracted to CO₂, in which we used a test concentration of 5 mmol/mol, or 0.5% CO₂ in air. Our behavioral bioassay design involved a glass T-tube (5 mmID), modified with a laboratory torch so that the ends of the two choice arms projected down at 45 degrees angles from horizontal, to provide pitfalls after the termites made a choice. A syringe pump was used with two 35 ml polyethylene syringes, one filled with ambient air and the other filled with 5 mmol/mol CO₂ in air. Teflon tubing conveyed the odors to the two arms of the T-tube, at 1.0 ml/min into each arm. We used a bubble meter to verify that the outflow from the center arm was 2.00 ml/min, to assure that there were no leaks. We allowed the syringe pump to run for 3 min immediately before the bioassay began, to allow the flow rates and gas concentrations inside the T-tube to come to equilibrium. The body of the T-tube was mounted horizontally on a foam rubber block. A group of 5 termites was placed inside a small Teflon holding tube for 15 min. To allow them to acclimate to the bioassay environment (NMR caps with small holes in them to allow gas flow were used to plug the ends of the holding tube). The acclimation period and the bioassay itself were done under reduced lighting. After the 15 min acclimation period, an NMR cap was removed from one end of the holding tube, and the tube was connected to the center arm of the T-tube. Typical responses of the termites in the T-tube were consistent with our conclusion that the term “attraction is the correct interpretation of their behavior. When a termite came to the choice point, it moved its antennae to one side and then the other, finally making a choice toward the CO₂ side. The side on which CO₂ was presented is randomized from replication to replication, to control for possible side-to-side bias in the bioassay. After making a choice, the termite moved along the arm about 2 cm to where it dropped off at 45 degrees, and slid down the chute into the pitfall. The number of termites that was attracted to the CO₂ side of the bioassay was significantly greater than the number that moved to the control side.

This experiment shows that CO₂ is useful in guiding termites to possible food sources. Second, the CO₂ concentration inside termite colonies is higher than that of ambient air, and termites use CO₂ as a guide in finding their way back to their colony.

EXAMPLE 17

A behavioral bioassay was used to demonstrate that termites are attracted to CO₂. When given a choice between a 5 mmol/mol concentration of CO₂ and a control containing ambient air (with a CO₂ concentration of 1 mmol/mol), the termites chose the 5 mmol/mol CO₂ side significantly more often. The bioassay apparatus was constructed from a horizontal glass T-tube with the ends of the choice arms bent downward at 45 to provide pitfalls. A syringe pump was used to provide slow, consistent delivery of candidate compounds to the two sides of the choice-test.

Materials and Methods

Insects. Termites were obtained from colonies of *Reticulitermes tibialis* maintained at Colorado State University. Colonies were originally obtained in the summer of 1997 from 9 sites in Larimer County, Colorado.

Termite collections: Termites were collected at three different sites in Larimer County: Big Hill Overlook, Lone Pine Wildlife refuge, and Poudre Canyon in the early part of June 1997. The termites were captured in one of two ways. Big Hill termites were captured using traps consisting of a square wood frame (6x6') made of 1x1 untreated wood. In the center of the frame was a piece of doubly corrugated wood cut to fit the frame. The cardboard was held in by a wire mesh with 1/4 inch holes. The traps were left for two weeks, in a spot where termites were seen. The termites were then removed from the traps and placed in petri dishes (see below). The second method (Lone Pine, and Poudre Canyon) was to look under logs and rocks. If a colony was located the individuals were collected using an aspirator and then transferred to a petri dish to be transported back to the lab.

Rearing: The termites were reared in petri dishes using moist paper towels and moist cardboard to provide cover and food. The termites were used in the bioassay usually within a week after collection but no less than 24 hours.

Bioassay Apparatus. The choice-test bioassay apparatus was constructed from a glass T-tube (5 mm inside diameter, 5 mm stem, with each branch 4.5 cm long). Each branch of the 'T' was bent downward (2 cm from junction of the T) at a 45 degree angle to form a 2.5 cm pitfall trap. A 5 mm NMR cap (cat. no. 100-0050, Drummond Scientific, Broomall, PA) with a 1 mm pinhole in it was firmly pushed over the end of each bent branch. A 25 cm length of Teflon tubing (0.8 mm ID) was

inserted (3 mm) into the pinhole of each NMR cap and the other end of the tubing was connected to a 35 ml polyethylene syringe (cat no. 106-0490, Sherwood Medical, St. Louis, MO). The two 35-ml polyethylene syringes used for each bioassay were connected to a syringe pump (Sage Model 355, Fisher Scientific, Pittsburgh, PA) which was adjusted to provide an airflow of 1.0 ml/min into each choice arm of the bioassay apparatus.

Bioassay Procedure. For bioassays, termite workers were collected using a camel-hair brush from a petri dish containing moist paper towels and cardboard, and were placed in a holding container constructed from a 3 cm length of Teflon tubing (8 mm ID). The container was plugged at one end with a NMR cap with two holes (1 mm) drilled in the bottom. A second NMR cap with a 4 mm hole drilled through it was inserted backwards into the other end of the Teflon tube. The NMR cap was then sealed with a small square of cellophane held in place with a plastic tube (a piece of plastic soda straw) that fit snugly over the open end. Termites (5 workers) were placed in the container and the top was sealed. The container was placed on its side (horizontal) and left undisturbed for 30 minutes. The T-tube apparatus was assembled and clamped horizontally on top of a block of foam rubber (12 cm x 12 cm) with a wire bent into a U-shape. The syringe pump was set to provide a flow of 1.0 ml/min from each syringe, and each syringe was connected with Teflon tubing to one choice arm of the T-tube. A flow meter was used to verify that the flow exiting the central arm of the T-tube was 2.0 ml/min, confirming the flow of volatiles through the apparatus, and verifying that there were no leaks in the connections. If the flow was inadequate, all connections were inspected and/or secured, and the flow was rechecked. After 3 minutes of pumping, the cellophane and plastic tube blocking the top of the holding container were removed and the entrance of the holding container was gently connected to the central arm of the T-tube, allowing larvae to crawl out and enter the apparatus. Bioassays were conducted for 15 minutes, after which the number of termites in each pitfall were recorded. Termites were not reused in subsequent tests. Prior to each test, the glass T-tube and all Teflon pieces were washed with soap and water, rinsed with water and heated at 80 degrees C in an oven for 30 min.

GC-MS Analysis Of CO₂. Mass spectrometry was used to determine CO₂ concentrations. A Hewlett-Packard Series II 5890 gas chromatograph interfaced with a Hewlett-Packard 5971 mass selective detector was operated in selected ion monitoring mode (SIM) for m/e 44 with a methyl silicone capillary column (30 m x 0.32 mm ID, RSL-150, Alltech, Inc.). A 10 mmol/mol mixture of CO₂ (a 300 ml glass bottle into which 3 ml of CO₂ were injected) was used as a standard to calculate the CO₂ concentrations of the unknown samples.

CO₂ Bioassay. A 5 mmol/mol concentration of CO₂ was used to test termite attraction. A 35 ml polyethylene syringe was rinsed with distilled water to moisten the inside of the syringe, and partially filled (approximately 5 ml) with ambient air. CO₂ (100 microliters) was obtained with a glass syringe from a tank containing pure (1 00%) CO₂ and injected into the 35 ml polyethylene syringe. Ambient air was then drawn into the syringe to fill it to a total volume of 35 ml, mixing the air and CO₂ thoroughly by turbulence. The gas mixture in the syringe was allowed to equilibrate for 15 minutes, and GC-MS-SIM was used to verify the CO₂ concentration prior to each bioassay. A second 35 ml polyethylene syringe was filled with ambient air for a control, and the CO₂ concentration was measured using GC-MS-SIM.

Statistical Analysis. Analysis of variance was conducted with Minitab (Addison-Wesley Publishing Co. Inc., Reading, MA). Fisher's LSD test was used for all *a posteriori* comparisons, with P=0.05.

Results

CO₂ Bioassay. Significantly more termites ($p < 0.05$) were attracted to the side containing 5 mmol/mol CO₂ than to the control side.

Discussion

We propose for the first time a specific behavioral role of CO₂ with regard to termites. Using a new behavioral bioassay, we have demonstrated that termites are attracted to low levels of CO₂. The workers exhibited a positive chemotactic response to CO₂ in the bioassay similar to that demonstrated by other soil-dwelling organisms.

Example 18

A behavioral bioassay was developed to test responses of newly hatched (neonate) larvae of western corn root worm *Diabrotica virgifera virgifera* LeConte to volatile compounds from corn plants, a major host for this insect. A glass Y-tube filled with glass beads was used to allow choice tests in a vertical direction and to reproduce the thigmotactic cues available to larvae in their natural soil environment. A syringe pump was used to provide slow, consistent delivery of candidate compounds to the 2 sides of the apparatus. Significantly more larvae were attracted to the side containing a germinating corn seed than to the side containing ambient air. In addition, significantly more larvae were attracted to the side containing cut corn roots than to the side containing an ambient air control. Carbon dioxide (CO₂) from corn roots previously has been implicated as an attractant for the larvae, and dose-response curves for larval attraction to CO₂ were obtained using different sources (different dilutions of carbonated water, the headspace over a carbonated water dilution, and different concentrations of CO₂ in air). The CO₂ concentrations for all sources were measured by mass spectrometry with selected ion monitoring at m/e 44. Neonate larvae were significantly attracted to concentrations of CO₂ as low as 1.125 ± 0.04 mmol/mol (concentration of CO₂ in ambient air on the control side was 0.99 ± 0.02 mmol/mol). Larvae were optimally attracted to 2.51--4.20 mmol/mol CO₂, but they were attracted to concentrations as high as 100 mmol/mol. Larvae were not attracted to 300 or 900 mmol/mol CO₂, and they exhibited toxic symptoms at these high concentrations. The concentration of CO₂ in soil near growing corn roots was 4.36 ± 0.31 mmol/mol, which was consistent with the behavioral optimum for the larvae. The concentration of CO₂ in soil that contained no corn was 1.38 ± 0.03 mmol/mol and the concentration in ambient air was 0.94 ± 0.01 mmol/mol.

Western Corn Root Worm, *Diabrotica virgifera virgifera* LeConte, is a major pest of corn, *Zea mays* L., in the United States (Krysan and Miller 1986). The larvae can survive only on corn and a few other species of Poaceae (Branson and Ortman 1967, 1970), and they have been reported to move as far as 1 m through the soil to find roots of a suitable host (Short and Luedtke 1970). Overwintering eggs hatch in the spring, and larvae must crawl through the soil to locate the roots on which they feed. One of the most important cues used by these larvae to locate corn roots is carbon dioxide (CO₂), which is given off by corn roots in the soil (Harris and Van Bavel

1957, Massimino et al. 1980, Desjardins 1985, Labouriau and Jose 1987). Strnad et al. (1986) first reported that western corn root worm larvae are highly attracted to CO₂, and subsequent investigators have confirmed this attraction (Hibbard and Bjostad 1988, MacDonald and Ellis 1990, Strnad and Dunn 1990, Jewett and Bjostad 1996). In laboratory bioassays, Hibbard and Bjostad (1988) showed that a cryogenic collection of volatile compounds from germinating corn seeds was attractive to 2nd instars of western corn root worm, and that CO₂ was present in the cryogenic collections. Jewett and Bjostad (1996) showed that dichloromethane is attractive to *Diabrotica* larvae, apparently because the structure of dichloromethane mimics CO₂ in its interaction with larval chemoreceptors.

Carbon dioxide alone is attractive to a number of soil invertebrates, including insect larvae (Klingler 1957, 1958, 1959, 1961, 1965, 1966; Paim and Beckel 1963b; Stadler 1971, 1972; Meeking et al. 1974; Doane et al. 1975; Jones and Coaker 1977, 1979), insect adults (Paim and Beckel 1963a, b), mites (Moursi 1962, 1970), chilopods (Moursi 1970), nematodes (Johnson and Viglierchio 1961; Klingler 1961, 1963, 1965; Gaugler et al. 1980; Prot 1980; Dusenbery 1987; Pline and Dusenbery 1987; Robinson 1995), and bacteria (Scher et al. 1985).

The minimum concentration of CO₂ required for attraction of western corn root worm larvae and the concentration for optimal attraction have not previously been determined. The objectives of the current study were to determine threshold concentrations of CO₂ for attraction of western corn root worm larvae and to determine the range of concentrations attractive to the larvae. If western corn root worm larvae are given a choice between a high and a low concentration of CO₂, the difference in concentration required to elicit a significant difference in attraction would be expected to increase as both concentrations are increased, and we tested this hypothesis as well.

In strong contrast to previous reports from our laboratory, we have recently concluded that CO₂ is the only volatile compound that attracts western corn root worm larvae to corn roots (E.J.B., unpublished data), and that other volatile compounds from corn roots play no role in attraction. Previously in our laboratory, a blend of 6-methoxy-2-benzoxazolinone and stearic, oleic, and linoleic acids was reported to enhance the attractiveness of CO₂ to 2nd instars (Hibbard and Bjostad 1988, 1989, 1990; Bjostad and Hibbard 1992; Hibbard et al. 1994), but these

compounds had little or no effect in field tests (Hibbard et al. 1995). We now believe that the apparent enhancement of larval attraction to CO₂ by a blend of 6-methoxy-2-benzoxazolinone and 3 fatty acids that we previously reported was caused by a series of experimental artifacts. Our new results indicate that it may be possible to use chemical or microbial sources of CO₂ in soil agroecosystems to interfere with orientation of western corn root worm larvae to corn roots, as a new tool in pest management (E.J.B., unpublished data).

Materials and Methods

Insects. Western corn root worms have been reared in our laboratory since 1986 (nondiapausing strain, originally obtained from J. Jackson, USDA--ARS, Brookings, SD). The insects were reared on corn plants grown in soil in an incubator by using methods described by Jackson (1985) and modified by Hibbard and Bjostad (1988).

Corn. Untreated, dried corn seeds (*Zea mays* L., cv 3055 provided courtesy of Gary D. Lawrance, Pioneer Hi-Bred International, Inc., Johnston, IA) were washed with liquid soap, soaked for 24 h in soapy water (1 drop of Ivory dishwashing liquid, Procter & Gamble, Cincinnati, OH, per liter of water), and rinsed thoroughly with water. For use in bioassays, the washed seeds were germinated 3 d on germination paper (Steel Blue, Anchor Paper, St. Paul, MN) in a closed polyethylene tub (30 by 15 cm). The plants typically reached a shoot length of 1 cm and a root length of 6 cm.

Bioassay Apparatus. The choice-test bioassay apparatus (Graph 18-1-A) was constructed from a glass Y-tube filled with glass beads to simulate the thigmotactic cues of the soil environment that are ordinarily encountered by western corn root worm larvae. The glass Y-tube was fabricated by a local glassblower (9.5 mm inside diameter, 60° angles, with each branch 3 cm long), and clamped to a ring stand with 2 branches of the "Y" facing down. A glass connection tube (4 cm long, 0.5 cm diameter) with a piece of vinyl screen (2.5-mm mesh) held over 1 end by a 0.5-cm section of Teflon tubing (6 mm inside diameter) was inserted snugly into the end of each of the arms of the Y-tube to support the glass beads. Glass beads (3 mm, cat. no. 11-312A, Fisher Scientific, Pittsburgh, PA) were poured into the top of the Y-tube,

filling the entire apparatus to within 0.5 cm of the top (250 beads). A 5-mm NMR tube cap (cat. no. 100-0050, Drummond Scientific, Broomall, PA) was fitted into the other end of each glass connection tube, with a hole to allow snug insertion of a 20-cm piece of slender Teflon tubing (0.8 mm inside diameter) for introduction of volatile chemical cues into each arm of the bioassay apparatus. Two techniques were used to introduce candidate chemical cues into the 2 arms of the apparatus: 1 used shell vials as chemical sources, and the other used syringes as chemical sources.

Shell Vial Sources. In this 1st approach (Graph 18-1-A), two 35-ml polyethylene syringes (cat. no. 106-0490, Sherwood Medical, St. Louis, MO) were filled with ambient air, and the air was pumped through shell vials containing candidate chemical cues. Glass shell vials (4 ml) with polyethylene caps were used (cat. no. B7785-1, Baxter Healthcare, McGaw Park, IL). A 35-ml syringe was snugly connected with slender Teflon tubing (20 cm) to a hole in the cap of the shell vial. A 2nd piece of slender Teflon tubing was used to connect the shell vial to 1 arm of the bioassay apparatus. The 2 syringes used for each bioassay were connected to a syringe pump (Sage Model 355, Fisher Scientific, Pittsburgh, PA) that provided an airflow through each shell vial containing a candidate chemical treatment, and subsequently into a choice arm of the bioassay apparatus. For the shell vial sources of candidate chemical compounds, the shell vial containing either a carbonated water dilution or a corn seed or cut corn roots was left open for 5 min to allow the gas concentrations to reach equilibrium. The vial was capped, and the syringe pump was started, providing an airflow of 1.0 ml/min from each syringe.

Syringe Sources. In this 2nd approach (Graph 18-2-A), 35-ml polyethylene syringes were filled directly with candidate chemical cues (such as the headspace from a container of germinating corn, a sample of CO₂ mixed with air, or the headspace from a bottle of carbonated water). Each of the 2 syringes was connected with slender Teflon tubing to 1 arm of the bioassay apparatus. The 2 syringes used for each bioassay were connected to a syringe pump that was adjusted to provide an airflow of 1 ml/min from each syringe.

Bioassay Procedure. For bioassays, 20 newly hatched 1st instars (0--12 h old) were collected from tubs containing eggs in soil (by using a camel's hair brush) and placed in a covered 5-mm NMR cap with 2 holes (1 mm diameter) drilled in the bottom (Graphs 18-1-A and 18-2-A). These holes were temporarily plugged with a

piece of wire bent into a U-shape. The open end of the NMR cap was sealed with a small square of cellophane held in place with a plastic tube (a piece of soda straw) that fit snugly over the open end. The Y-tube apparatus was assembled and filled with glass beads and the appropriate treatment and control sources (shell vials or syringes) were connected to the arms of the Y-tube. The syringe pump was set to provide a flow of 1 ml/min and turned on. A flow meter was used to verify that the flow exiting the top of the Y-tube was 2 ml/min, confirming the flow of volatiles through the apparatus and verifying that there were no leaks in the connections. If the flow was inadequate, all connections were inspected and secured, and the flow was rechecked. After 3 min of pumping, the wire piece blocking the 2 holes in the NMR cap was removed and the cap was placed in the top of the Y-tube, allowing larvae to crawl out through the 2 holes and down into the glass beads. Bioassays were conducted for 30 min. The entire Y-apparatus was disassembled, and the positions of the larvae were recorded. Larvae were not reused in subsequent tests. Before each test, all glass parts of the apparatus were washed with soap and water, rinsed with water, and heated at 80°C in an oven for 30 min.

GC-MS Analysis of CO₂. Mass spectrometry was used to determine CO₂ concentrations. A Hewlett-Packard Series II 5890 gas chromatograph interfaced with a Hewlett-Packard 5971 mass selective detector was operated in selected ion monitoring mode (SIM) for m/e 44 with a methyl silicone capillary column (30 m long, 0.32 mm inside diameter, RSL-150, Alltech, Deerfield, IL). A 10-mmol/mol mixture of CO₂ (a 300-ml glass bottle into which 3 ml of CO₂ was injected) was used as a standard to calculate the CO₂ concentrations of the unknown samples.

Germinating Corn Seed Versus Air. Using the shell vial source technique, germinating corn seeds were tested to determine whether larvae could detect volatile compounds produced by the growing seeds and follow them through a glass bead medium to the source. Individual washed corn seeds were placed in glass shell vials (4 ml) with a moistened piece of filter paper inside. The vials were placed on moistened germination paper inside a covered plastic container (30 by 15 cm) and germinated for 3 d. A vial containing a single 3-d-old germinating seed was removed from the covered plastic container just before testing and connected to the bioassay apparatus. An empty shell vial was connected to the other side as a control. The CO₂

concentrations of the germinating corn seeds and the control were determined by using GC-MS-SIM.

Cut Corn Roots Versus Air. In a companion experiment, cut corn roots were tested to determine whether larvae were attracted to volatile compounds produced by the roots alone. Corn roots (14.5 cm, 3 d old) were cut into 2--3 cm lengths and placed into 1 shell vial. The other shell vial (control side) contained ambient air. The CO₂ concentrations of the cut corn roots and the control were determined by using GC-MS-SIM.

Corn Headspace Bioassay. Using the syringe source technique, the headspace over germinating corn seedlings was tested to determine the larval response to corn volatiles in the glass bead apparatus. Washed corn seeds were spread on moistened germination paper inside a covered plastic container (30 by 15 cm) and germinated for 3 d to allow volatile corn compounds to be produced. A 35-ml polyethylene syringe was filled with the headspace containing these volatile compounds by means of a 25 cm length of slender Teflon tubing inserted into a hole drilled into the cover. The control syringe was filled from an identical plastic container containing only moistened germination paper. The CO₂ concentrations of the syringes were determined by using GC-MS-SIM before each bioassay.

Consistency of CO₂ Delivery. The consistency of the CO₂ concentration delivered into the bioassay apparatus was measured using GC-MS-SIM. For syringe sources, a 35-ml polyethylene syringe was partially filled with ambient air (5 ml) and 80 µl of CO₂ (obtained with a glass syringe from a tank containing pure [100%] CO₂) was injected into the syringe. Ambient air was then drawn into the syringe to fill it, mixing the air and CO₂ thoroughly by turbulence at the same time. A syringe containing 800 µl of CO₂, and another containing only ambient air, also were prepared. The syringes were allowed to equilibrate for 30 min before they were connected to the syringe pump (set at a flow of 1 ml/min). After 3 min of pumping, a 2-µl sample was taken from 5 cm inside a 20-cm length of Teflon tubing exiting from each syringe, by using a 10-µl (Hamilton) syringe. To test consistency of CO₂ release from the syringes, samples were taken at 0, 10, 20, and 30 min (following the initial 3-min pumping interval) and analyzed using GC-MS-SIM. For behavioral bioassays, samples were taken 5 min before the start of the bioassay from 5 cm inside the syringe.

For shell vial sources, CO₂ concentrations were measured from the 0, 1, 3, 10, 30, and 100% dilutions of carbonated water. A dilution of carbonated water (1 ml) (see preparation below) was slowly dispensed into a shell vial (4 ml capacity) with a 1-ml Pasteur pipette. The vial was left open for 5 min to allow the CO₂ gas concentration to reach equilibrium. A 35-ml polyethylene syringe on the syringe pump was used to pump air through the shell vial at 1 ml/min. After 3 min of pumping, a 2- μ l sample of the headspace was taken from 5 cm inside a 20-cm length of Teflon tubing exiting from the shell vial, using a 10- μ l (Hamilton) syringe. To test consistency of CO₂ release from the shell vials, samples were taken at 0, 10, 20, and 30 min and analyzed using GC-MS-SIM.

CO₂ Bioassay. In a preliminary experiment, a 10-mmol/mol concentration of CO₂ was used to test larval attraction. A 35-ml polyethylene syringe was rinsed with distilled water to moisten the inside of the syringe, and partially filled (5 ml) with ambient air. The CO₂ (350 μ l) was obtained with a glass syringe from a tank containing pure (100%) CO₂ and injected into the 35-ml polyethylene syringe. Ambient air was then drawn into the syringe to fill it to a total volume of 35 ml, mixing the air and CO₂ thoroughly by turbulence. The gas mixture in the syringe was allowed to equilibrate for 15 min, and GC-MS-SIM was used to verify the CO₂ concentration before each bioassay. A 2nd 35-ml polyethylene syringe was filled with ambient air for a control, and the CO₂ concentration was measured using GC-MS-SIM.

CO₂ (Dose--Response). In subsequent experiments, mixtures of CO₂ and ambient air were tested to determine the larval response to a range of CO₂ concentrations. A 35-ml syringe was rinsed with distilled water and partially filled (5 ml) with ambient air. Different amounts of 100% CO₂ were obtained with a smaller glass syringe from a tank and injected into the 35-ml syringe. Ambient air was then drawn into the 35-ml syringe to fill it and mix the gases by turbulence as the syringe was loaded. A 2nd 35-ml polyethylene syringe was filled with ambient air for a control. Measurements with GC-MS-SIM confirmed that the CO₂ concentrations reached equilibrium after 15 min. The CO₂ concentration of the syringes was determined by using GC-MS-SIM analysis before each bioassay.

CO₂ Selective Response. Pairs of CO₂ mixtures were tested to determine if the larvae could detect small differences in CO₂ concentration. In a typical test, a

syringe containing 1 mmol/mol CO₂ was connected to 1 arm of the Y-tube, and a syringe containing 1.5 mmol/mol CO₂ was connected to the opposite arm of the Y-tube. In subsequent tests, comparisons were made for 2 versus 2.5 mmol/mol, 5 versus 5.5 mmol/mol, 10 versus 10.5 mmol/mol, and 20 versus 20.5 mmol/mol CO₂. The CO₂ concentration of the syringes was determined by using GC-MS-SIM analysis before each bioassay. Using this same procedure, comparisons also were made to determine if larvae could detect even smaller differences (0.25, 0.125, and 0.00 mmol/mol) in CO₂ concentration. Comparisons were made for 1 versus 1.25, 2 versus 2.25, 5 versus 5.25, 10 versus 10.25, and 20 versus 20.25 mmol/mol CO₂, for 1 versus 1.125, 2 versus 2.125, 5 versus 5.125, 10 versus 10.125, and 20 versus 20.125 mmol/mol CO₂, and also for 1 versus 1, 2 versus 2, 5 versus 5, 10 versus 10, and 20 versus 20 mmol/mol of CO₂.

Diluted Carbonated Water (Dose--Response). It has previously been shown that carbonated water can be used as a source of CO₂ to attract 2nd-instar western corn root worms (Jewett and Bjostad 1996). Dilutions of carbonated water (Canada Dry Club Soda, Cadbury Beverages, Stamford, CT) in distilled water were evaluated for attraction of western corn root worm larvae. With this approach, handling of carbonated water was conducted with slow pouring of large volumes of liquid, and all transfers into shell vials were made with large-diameter pipettes to minimize outgassing. Six concentrations of carbonated water (0, 1, 3, 10, 30, and 100%) were tested. A new, unopened bottle of carbonated water was used each day to prepare the dilutions. To prepare the 10 and 30% dilutions, the appropriate amount of distilled water was measured in a glass graduated cylinder and poured into a 300-ml glass bottle. The right amount of carbonated water was then measured in a graduated glass cylinder and poured slowly into the same bottle to minimize outgassing of CO₂. The diluted mixture (150 ml total volume) was stirred gently with a glass rod. The 10 and 30% dilutions were used to prepare the 1 and 3% dilutions, respectively. For bioassays, each dilution of carbonated water (1 ml) was slowly dispensed into a shell vial (4 ml capacity) with a 1-ml Pasteur pipette. Distilled water (1 ml) was placed into a 2nd vial (control). The vials were left open for 5 min to allow the CO₂ gas concentration to reach equilibrium, then were connected to the bioassay apparatus. The CO₂ concentration in the headspace above the carbonated water dilutions in the shell vials was determined by using GC-MS-SIM.

Shell Vial Control Bioassays. Control tests with air on both sides of the Y-tube and with carbonated water on both sides of the Y-tube were conducted to determine if there was an intrinsic tendency for the larvae to move to 1 side or the other when chemical cues were absent, or when CO₂ was present. For the 1st test, shell vials containing ambient air were connected to both arms of the Y-tube. For the 2nd test, a 3.5-ml plastic syringe with a 2-cm needle was used to inject 0.5 ml of carbonated water (100% concentration) into 2 shell vials. The vials were allowed to stand open for 5 min before testing to allow the CO₂ gas concentration to reach equilibrium.

Syringe-Source Control Bioassays. Control tests with air on both sides of the Y-tube and with CO₂ on both sides were conducted to determine if there was an intrinsic tendency for the larvae to move to 1 side or the other when chemical cues were absent, or when CO₂ was present. For the 1st test, two 35 ml polyethylene syringes were rinsed with distilled water, filled with ambient air, and connected to both arms of the Y-tube. For the 2nd test, two 35-ml syringes were rinsed with distilled water and partially filled (5 ml) with ambient air. The CO₂ (100 µl, obtained with a glass syringe from a tank) was injected into each syringe, and room air was drawn into the syringes to fill them to a total volume of 35 ml. The mixtures were allowed to equilibrate for 15 min, and GC-MS-SIM analysis was used to verify that the CO₂ concentrations were the same in both syringes before each bioassay.

CO₂ Analysis of Corn Plants in Soil. The bottom of a round, plastic tub (11 cm high, 17 cm diameter) was covered with 3 cm of soil, and 40 ml of water were added. Washed corn seeds (40--50) were distributed on top of the soil and the seeds were covered with an additional 3 cm of soil. The tubs were tightly covered. The lids were removed after 3 d, and the soil was kept slightly moist by adding water daily. Measurements of CO₂ were taken from the soil when the plants were 6--8 d old. A piece of metal wire (5.3 cm) was inserted into a glass tube (5 cm long, 1 mm inside diameter) so that the wire projected 3 mm from the end of the glass tube. The tube was inserted, wire first, 4 cm into the soil. The wire plug was removed from the glass tube, leaving a 3-mm gap in the soil just below the end of the glass tube. The needle of a 10-µl Hamilton syringe was inserted into the glass tube so that it projected 1 mm into the gap, and a 5-µl sample of soil headspace was removed. Samples were taken from different locations in the tub to minimize disturbance of the soil CO₂

concentrations. The CO₂ concentration of the soil headspace was determined by using GC-MS-SIM. Using the same method, samples were taken from control tubs containing soil alone.

5 **Statistical Analysis.** Analysis of variance (ANOVA) was conducted with Minitab (Addison--Wesley, Reading, MA). The Fisher LSD test was used for all a posteriori comparisons, with $P = 0.05$.

Results

10 **Germinating Corn Seed Versus Air Choice Test.** In experiments using shell vial sources, significantly more western corn root worm larvae ($P < 0.05$) were attracted to the side containing the germinating corn seed than to the control side (Graph 18-1-B). The CO₂ concentration of the headspace above the germinating corn seed was 6.04 ± 0.83 (mean \pm SEM) mmol/mol, and the CO₂ concentration of the headspace on the control side was 0.99 ± 0.08 mmol/mol (Graph 18-1-D).

15 **Cut Corn Roots Versus Air Choice Test.** Significantly more western corn root worm larvae ($P < 0.05$) were attracted to the side containing cut corn roots than to the control side (Graph 18-1-C). The CO₂ concentration of the headspace above germinating corn roots was 2.97 ± 0.15 mmol/mol, and the CO₂ concentration of the headspace on the control side was 0.99 ± 0.08 mmol/mol (Graph 18-1-E).

20 **Corn Headspace Bioassay.** In bioassays with syringe sources, significantly more western corn root worm larvae ($P < 0.05$) were attracted to the side containing the headspace over germinating corn seeds than to the control side (Graph 18-2-B). The CO₂ concentration of the headspace above the germinating corn seeds was 5.38 ± 0.45 mmol/mol, and the CO₂ concentration of the headspace on the control side was 1.14 ± 0.13 mmol/mol (Graph 18- 2-D).

25 **CO₂ Bioassay.** In a preliminary experiment to verify attraction of the larvae to syringe sources containing CO₂, significantly more western corn root worm larvae ($P < 0.05$) were attracted to the side containing 10 mmol/mol CO₂ (10.43 ± 0.18 mmol/mol) than to the control side (Graph 18-2-C). The CO₂ concentration of the control side was 0.93 ± 0.04 mmol/mol (Graph 18-2-E).

30 **Consistency of CO₂ Delivery.** The release of CO₂ from syringe sources was highly consistent over the course of a 30-min bioassay interval (Graph 18-3-A). The release of CO₂ from shell vial sources was consistent over the course of a 30 min

bioassay interval for the lower doses tested (0, 1, 3, and 10%), but not for the higher doses (30 and 100%) (Graph 18-3-B).

CO₂ (Dose--Response). The larvae were attracted to a wide range of CO₂ concentrations. The lowest concentration of CO₂ that was attractive to the larvae (Graph 18-4) was 1.34 ± 0.05 mmol/mol (10 μ l of CO₂ added to syringe) ($P < 0.05$), where the control CO₂ concentration was 0.91 ± 0.03 . The highest dose to which the larvae were attracted was 85.60 ± 1.20 mmol/mol (3 ml of CO₂ added to syringe). They were not attracted to 300 mmol/mol (10 ml of CO₂ added to syringe) or 900 mmol/mol (30 ml of CO₂ added to syringe) concentrations (Graph 18-4).

CO₂ Selective Response. Significantly more larvae were attracted (Graph 18-5) to the higher CO₂ concentration for 1 versus 1.50 mmol/mol, for 2 versus 2.50 mmol/mol, for 5 versus 5.50 mmol/mol, and for 10 versus 10.50 mmol/mol, but no difference in attraction was observed for 20 versus 20.50 mmol/mol of CO₂. When smaller CO₂ differences were tested (0.25 mmol/mol), fewer significant differences were observed. Larvae were more attracted to the higher CO₂ concentration for 1 versus 1.25 mmol/mol, and for 2 versus 2.25 mmol/mol, but no difference in attraction was observed for 5 versus 5.25 mmol/mol, for 10 versus 0.25 mmol/mol, or for 20 versus 20.25 mmol/mol. At the smallest CO₂ difference tested, significantly greater attraction was observed to 1.125 mmol/mol than to 1 mmol/mol (the actual CO₂ concentration of the treatment side was 1.18 ± 0.05 mmol/mol, and the actual control concentration was 1.06 ± 0.05 mmol/mol), but no difference in attraction was observed in any of the tests at higher concentrations. In control tests with equal amounts of CO₂ on both sides (1, 2, 5, 10, or 20 mmol/mol), no significant differences in attraction were observed.

Diluted Carbonated Water (Dose--Response). In bioassays with shell vial sources, the 3% dilution of carbonated water was the lowest attractive dose (Graph 18-6-A) ($P < 0.05$). The larvae responded optimally to the 10% dilution of carbonated water, and all concentrations (3, 10, 30, and 100%) greater than the 1% dilution were significantly more attractive ($P < 0.05$) than the control (distilled water). The CO₂ concentration of the control (distilled water) was 1.42 ± 0.08 mmol/mol, and the concentration of the 1% dilution was 1.48 ± 0.10 mmol/mol (Graph 18-6-B). The CO₂ concentration of the 3% dilution was 1.91 ± 0.09 mmol/mol, and the 10% dilution produced 2.55 ± 0.12 mmol/mol of CO₂. The 30%

dilution produced 6.06 ± 0.36 mmol/mol of CO₂, and the 100% carbonated water produced 24.49 ± 0.22 mmol/mol of CO₂.

Shell Vial Control Bioassays. There was no significant difference ($P > 0.05$) between the numbers of larvae moving to the right and to the left when no chemical treatment was present on either side of the choice test. Western corn root worm larvae moved slowly through the glass beads, and after 30 min, equal numbers of larvae were found in the right and left arms of the Y-tube. The CO₂ concentration in the shell vials containing ambient air was 0.99 ± 0.08 mmol/mol. Larvae also chose equally between the right and left sides of the choice test when carbonated water was present on both sides in shell vial sources ($P > 0.05$). Each shell vial of carbonated water produced 24.49 ± 1.31 mmol/mol of CO₂.

Syringe Source Control Bioassays. There was no significant difference ($P > 0.05$) between the numbers of larvae moving to the right and to the left when ambient air was present on both sides of the choice test from syringe sources. Larvae also chose equally between the right and left sides of the choice test when CO₂ was present on both sides ($P > 0.05$). The CO₂ concentration from the syringes was 4.37 ± 0.04 mmol/mol (right) and 4.36 ± 0.04 mmol/mol (left).

CO₂ Analysis of Corn Plants in Soil. The CO₂ concentration in the soil atmosphere in tubs containing 8-d-old growing corn plants was 4.36 ± 0.31 mmol/mol (measured by GC-MS-SIM). The concentration of CO₂ in tubs containing soil alone was 1.38 ± 0.03 mmol/mol, and the concentration in the ambient air was 0.94 ± 0.01 mmol/mol.

Discussion

A key component of the current study was the design of an improved behavioral bioassay specifically to test attraction of 1st-instar western corn root worm to volatile compounds from corn plants. Previous studies of western corn root worm behavior have involved either the use of petri dish or arena bioassay designs (Branson and Ortman 1967, 1970; Strnad et al. 1986; Hibbard and Bjostad 1988; Jewett and Bjostad 1996), or a soil-containing chamber (Strnad and Bergman 1987, Gustin and Schumacker 1989, Hibbard and Bjostad 1989, MacDonald and Ellis 1990). Studies of western corn root worm responses to chemical cues from corn previously have been carried out in our laboratory with 2nd instars using a petri dish bioassay (Hibbard and Bjostad 1988). Second instars were used in these previous studies because they were more robust and easier to handle, and because the delicate 1st instars responded poorly in the petri dish bioassays. However, the burden of host location lies with the neonate larvae, who must locate suitable host plant roots in a limited amount of time to ensure survival to adulthood (Strnad and Bergman 1987, Branson 1989, MacDonald and Ellis 1990).

During initial observations, some important behaviors of the newly hatched larvae were noted and provided guidance in the development of the new bioassay. First, the larvae exhibited a tendency to move downward. They moved in a downslope direction when placed on a flat, slightly tilted surface (petri dish), and also moved downward when they were allowed to move through a porous, soil-like medium such as glass beads. Second, the larvae appeared to use thigmotactic cues to maneuver. When placed in the center of a small (5 cm) petri dish, the larvae quickly moved to the outside of the dish and continued to crawl around the circumference of the dish, keeping their bodies in contact with the outside edge at all times. If a piece of filter paper was placed in the petri dish, the larvae either positioned themselves between the edge of the paper and the edge of the dish and continued to crawl around the outside circumference, or they crawled beneath the paper before coming to rest. From these observations, we concluded that geotropic tendency and use of thigmotactic cues are apparently important elements of neonate western corn root worm larval behavior, and these were given special consideration when designing this new behavioral bioassay.

The new bioassay design accommodates the small size of the neonate larvae, provides a choice in the vertical direction, and uses glass beads to simulate the thigmotactic cues that are ordinarily encountered by western corn root worm larvae in their natural soil environment. The glass bead apparatus also can be adapted to facilitate the testing of a variety of chemical sources. We have verified in choice tests that corn roots and germinating corn seeds are attractive to western corn root worm larvae. In addition, gaseous mixtures of CO₂ were shown to attract newly hatched western corn root worm larvae in this behavioral bioassay, and the headspace above diluted carbonated water also was found to be attractive.

Neonate larvae exhibited a positive chemotactic response to CO₂ in the glass bead bioassay similar to that demonstrated previously using other bioassay designs (Strnad et al. 1986, Hibbard and Bjostad 1988, MacDonald and Ellis 1990, Jewett and Bjostad 1996). In the CO₂ dose--response experiment, the larvae were able to detect and were attracted to levels of CO₂ as small as 1.34 ± 0.05 mmol/mol when the control (ambient air) contained 0.91 ± 0.03 mmol/mol.

In syringe source bioassays, the larval response to CO₂ increased with each increase in the amount of CO₂ added to the syringe mixtures (1, 3, 10, μ l of CO₂) (Graph 18-4) when the control side contained 1.00 ± 0.09 mmol/mol of CO₂. In the dose--response test, the attractive range of concentrations was from 1.34 ± 0.05 to 85.6 ± 1.20 mmol/mol. The most attractive concentrations of CO₂ were 2.51 ± 0.13 mmol/mol (30 μ l of CO₂ added to the syringe), and 4.20 ± 0.21 mmol/mol (100 μ l added to the syringe). This range of attractive concentrations of CO₂ is consistent with the level of CO₂ produced by a germinating corn seed in a shell vial (6.04 ± 0.83 mmol/mol), cut corn roots in a shell vial (2.97 ± 0.15 mmol/mol), and also with the concentration found in the headspace above 50 g (dry wt) of germinating corn seeds (5.38 ± 0.45 mmol/mol). The concentration of CO₂ measured in soil near the roots of growing corn plants (4.36 ± 0.31 mmol/mol) was consistent with the optimally attractive range of concentrations (2.51 ± 0.13 to 4.20 ± 0.21 mmol/mol), indicating that the bioassay technique produced gradients of CO₂ similar to those that are behaviorally active in the soil.

The ability of the larvae to detect small differences in concentration at low base levels also was detected in the selective response experiment, in which the larvae were consistently attracted to the higher concentration of CO₂ when the treatment side

was 1 mmol/mol, even when the difference between the 2 choices was as low as 0.125 mmol/mol. In this series of experiments, the larvae were 1st attracted to a CO₂ concentration that was 12.5% higher than the control when the control contained 1, 2, 5, 10, and 20 mmol/mol CO₂. This degree of sensitivity to CO₂ has been demonstrated previously for other insects. Doane et al. (1975) demonstrated that wireworm larvae respond to CO₂ differences as small as 0.02% (0.20 mmol/mol). Pline and Dusenbery (1987) made the same observations for plant-parasitic nematodes. They found that the CO₂ threshold for nematode response was 0.01% (0.10 mmol/mol) at low baseline levels of CO₂ (0.1%) but was 0.05% (0.50 mmol/mol) when the baseline concentration was higher (1.0%) (10 mmol/mol).

In the current study, western corn root worm larvae were not attracted to 300 or 900 mmol/mol of CO₂, and they exhibited toxic symptoms at these high concentrations. Larvae remained in the cap, or in the top 0.5 cm of glass beads, throughout the bioassay period. They were lethargic when removed from the apparatus, but recovered normal movement after 5--10 min. Doane et al. (1975) reported a similar lack of response to high concentrations of CO₂ by plant-parasitic nematodes.

Although small amounts of CO₂ have a stimulatory effect on many insects, high levels of the gas act as an anesthetic by inhibiting bioelectrical responses of the insect nervous system (Nicolas and Sillans 1989).

The ability to detect and respond to small differences in CO₂ concentration may be important in host location by neonate western corn root worm larvae. Strnad et al. (1986) demonstrated that 1st instars follow a gradient of CO₂ to its source, and that they respond to increases in the gradient by exhibiting a reduction in the number of turns and direction changes. Our results indicate that the larvae not only detect these changes but also when given a choice of 2 different concentrations of CO₂, are attracted to the higher concentration and follow it toward the source. As shown by Branson (1989) and Strnad and Bergman (1987), neonate western corn root worm larvae die if they do not locate food within 3 d after hatching, and their survival to adulthood is significantly reduced if it takes them more than 24 h to find the roots of a suitable host plant. In more recent studies (MacDonald and Ellis 1990), western corn root worm larvae survived after 24 h of starvation, and some were able to survive for as long as 13 d with adequate temperatures and soil moisture. In the soil surrounding

a growing corn plant, a CO₂ gradient may form around the entire root mass. Western corn root worm larvae may use their ability to detect differences in concentration to orient directly to the root of the corn plant and avoid losing valuable time searching the entire area in which the roots are growing.

5 We propose using CO₂ to attract soil organisms (insects, nematodes, mites) away from their host plants or to confuse them so that they are unable to locate host plants. Sources of CO₂ include carbonated water. Sufficient CO₂ gradients can be produced by granules of potassium bicarbonate coformulated with an acid and a pesticide that are broadcast or incorporated into the soil. We are the first to
10 appreciate the use of organic sources to achieve a slow release of CO₂ for control of soil organisms. Calcium alginate co-encapsulated with yeast and a nutrient substrate, starch granules and k-carrageenan encapsulation can also be used as formulations for microbial pesticides and chemical or biological sources of CO₂ can be incorporated into these granules to attract and kill soil pests.

15 **Graph 18-1.** (A) Glass bead bioassay apparatus with candidate chemical cues in shell vials. (B) Choice test bioassay with a germinating corn seed versus air. (C) Choice test bioassay with cut corn roots (0.34 g) versus air. (D) CO₂ concentrations (measured with GC-MS-SIM) of germinating corn seed and air in shell vials. (E) Concentrations of CO₂ (measured with GC-MS-SIM) of cut corn roots and air in shell
20 vials. Significant differences ($p < 0.05$) are indicated by different lower case letters. Bars represent standard errors. WCR, western corn root worm.

Graph 18-2. (A) Glass bead bioassay apparatus with candidate chemical cues in syringes. (B) Choice test bioassay with headspace over germinating corn seeds versus air. (C) Choice test bioassay with CO₂ (10 mmol/mol) versus air. (D)
25 Concentrations of CO₂ (measured with GC-MS-SIM) of headspace over germinating corn seeds and air in syringes. (E) Concentrations of CO₂ (measured with GC-MS-SIM) of CO₂ (10 mmol/mol) and ambient air in syringes. Significant differences ($p < 0.05$) are indicated by different lower case letters. Bars represent standard errors. WCR, western corn root worm.

30 **Graph 18-3.** (A) Concentrations of CO₂ (measured with GC-MS-SIM) from syringes measured every 10 min with syringe pump turned on. (B) Concentrations of CO₂ (measured with GC-MS-SIM) from shell vials measured every 10 min with

syringe pump turned on. Bars represent standard errors (most standard error bars are too small to be visible on the graph).

Graph 18-4. (A) Choice-test bioassay with CO₂ in syringe sources. (B) CO₂ concentrations (measured with GC-MS-SIM) of mixtures in syringes. Significant differences ($P < 0.05$) are indicated by different lower case letters. Bars represent standard errors (all standard error bars are too small to be visible on the graph).

Graph 18-5. Choice-test bioassay with syringe sources containing (A) 1, (B) 2, (C) 5, (D) 10, and (E) 20 mmol/mol minimum CO₂ concentrations. Significant differences ($P < 0.05$) are indicated by different lower case letters. Bars represent standard errors.

Graph 18-6. (A) Choice-test bioassay with shell vials containing different dilutions of carbonated water. (B) CO₂ concentrations (measured with GC-MS-SIM) of carbonated water dilutions. Significant differences ($P < 0.05$) between each treatment and control are indicated by different lower case letters. Bars represent standard errors.

Graph 18-7 (A) Choice-test bioassay with syringe sources containing the headspace from different dilutions of carbonated water. (B) CO₂ concentrations (measured with SIM-GC-MS) from the headspace over each dilution of carbonated water. Significant differences ($p < 0.05$) in attraction to a particular dose of CO₂ and its corresponding control are indicated by different lower case letters. Bars represent standard errors (many are too small to be visible).

Graph 18-8. Control choice test bioassays with (A) shell vials containing air on both sides, (B) shell vials containing carbonated water on both sides, (C) syringes containing air on both sides, and (D) syringes containing CO₂ on both sides. Significant differences ($p < 0.05$) are indicated by different lower case letters. Bars represent standard errors.

Graph 18-9. CO₂ concentrations (measured with SIM-CG-MS) from soil near growing corn roots, soil alone and ambient air. Significant differences ($p < 0.05$) are indicated by different lower case letters. Bar represent standard errors.

GRAPH 18-1A

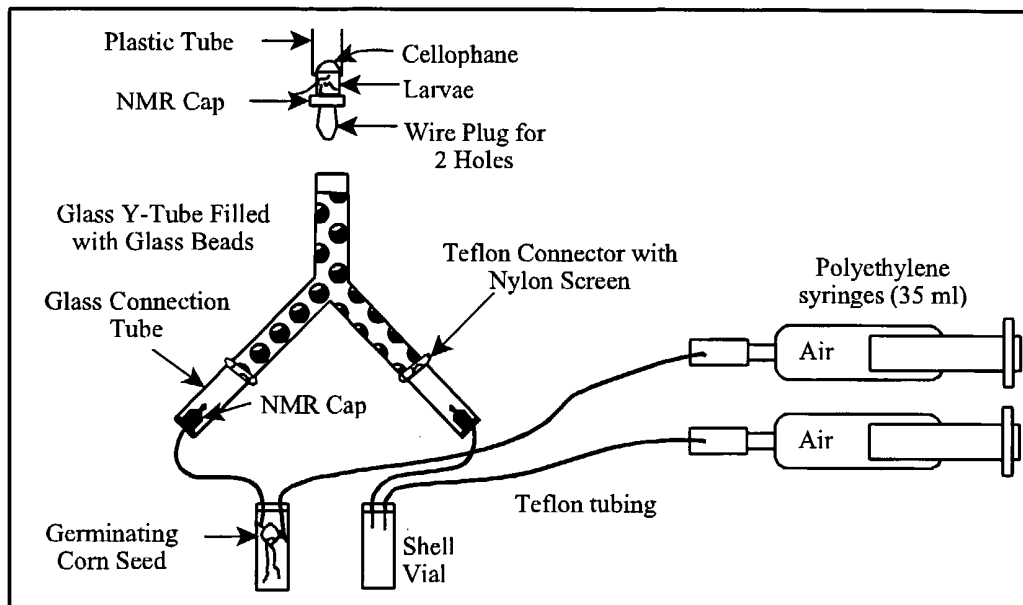

GRAPH 18-1B

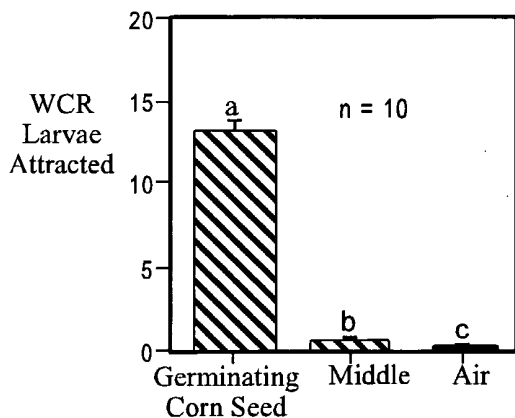

GRAPH 18-1C

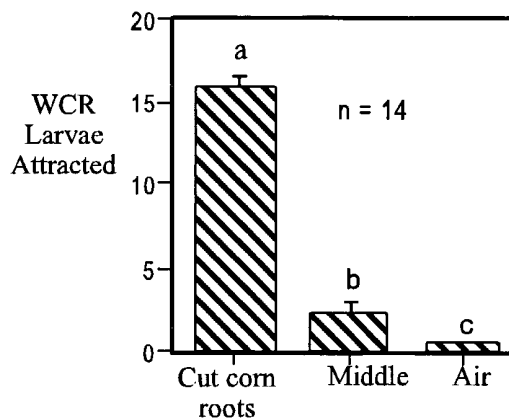

GRAPH 18-1D

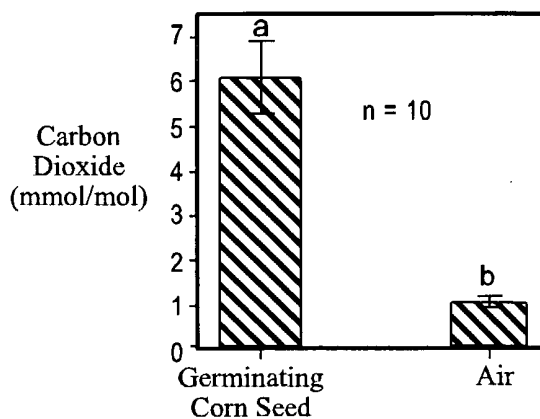

GRAPH 18-1E

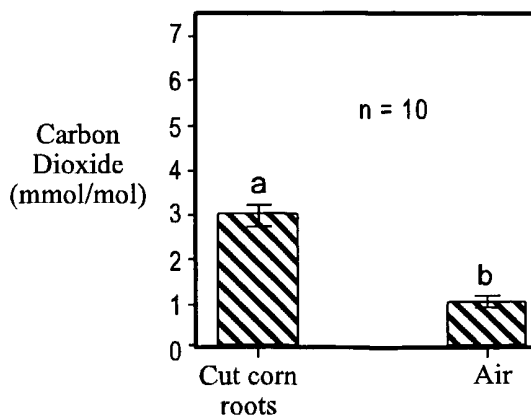

GRAPH 18-2A

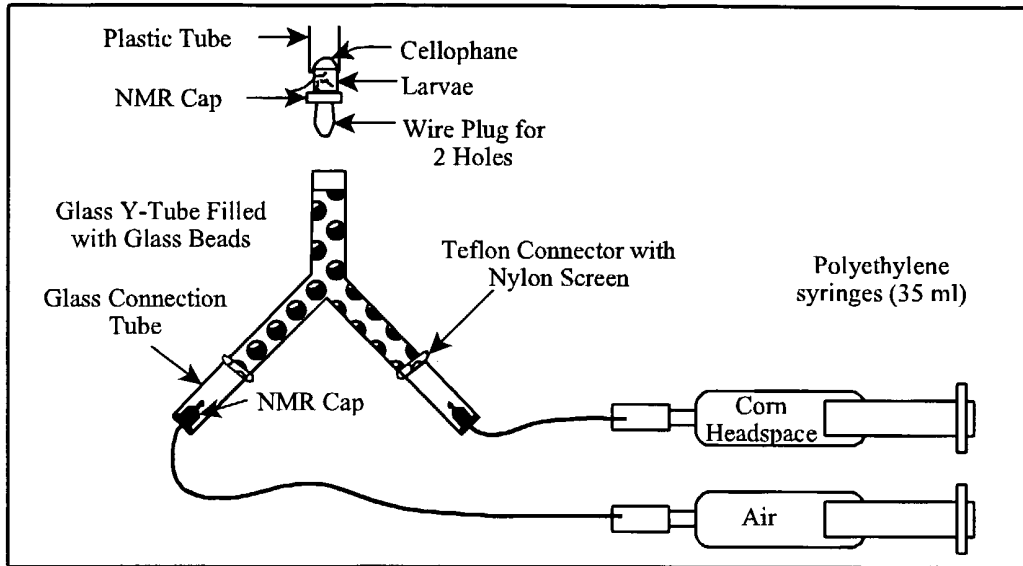

GRAPH 18-2B

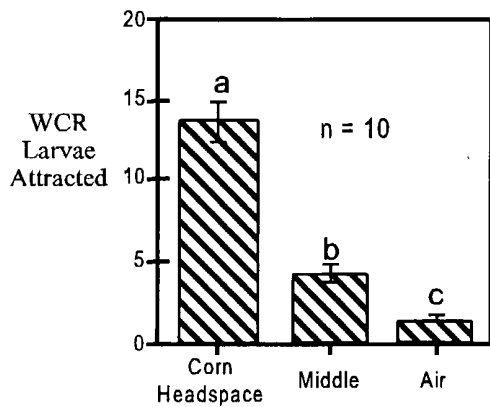

GRAPH 18-2C

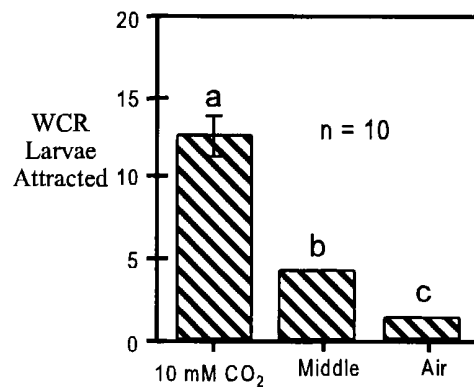

GRAPH 18-2D

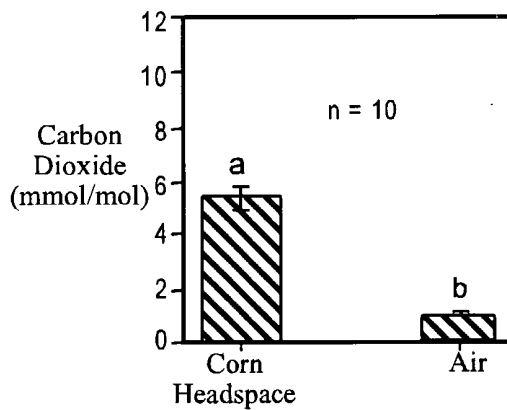

GRAPH 18-2E

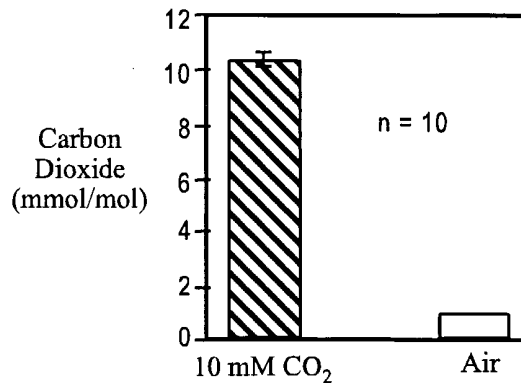

GRAPH 18-3

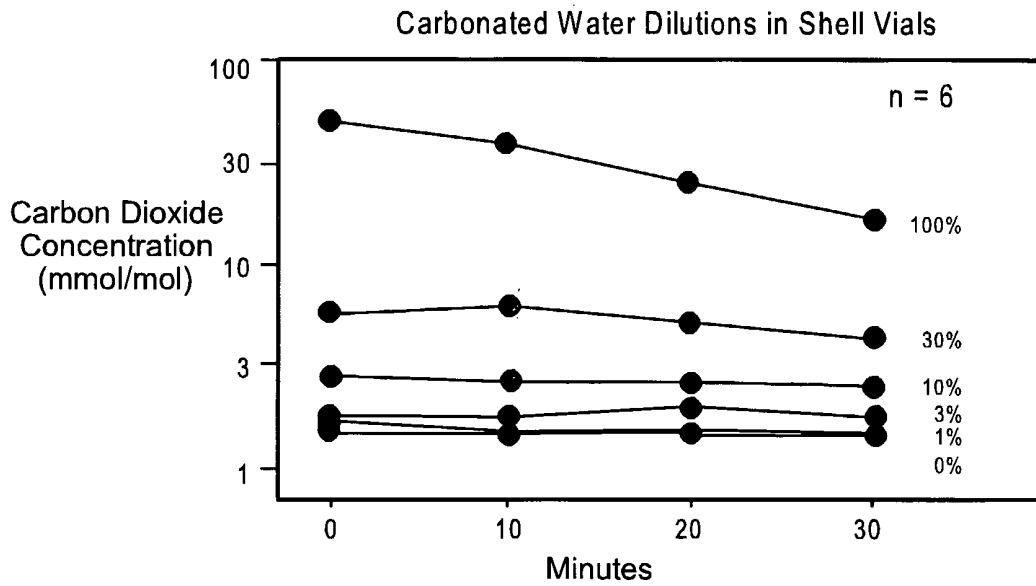
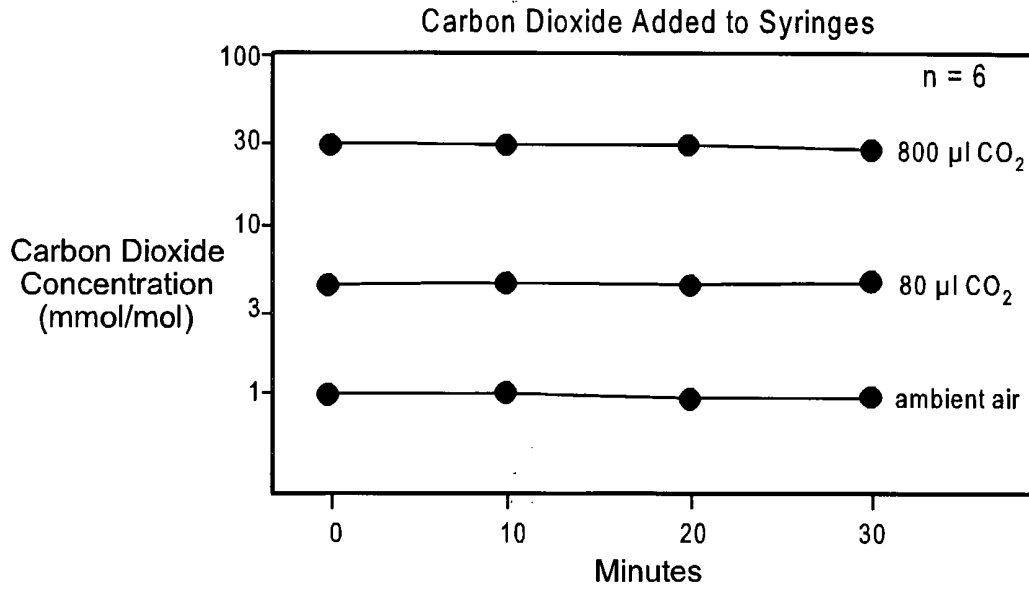

GRAPH 18-4A

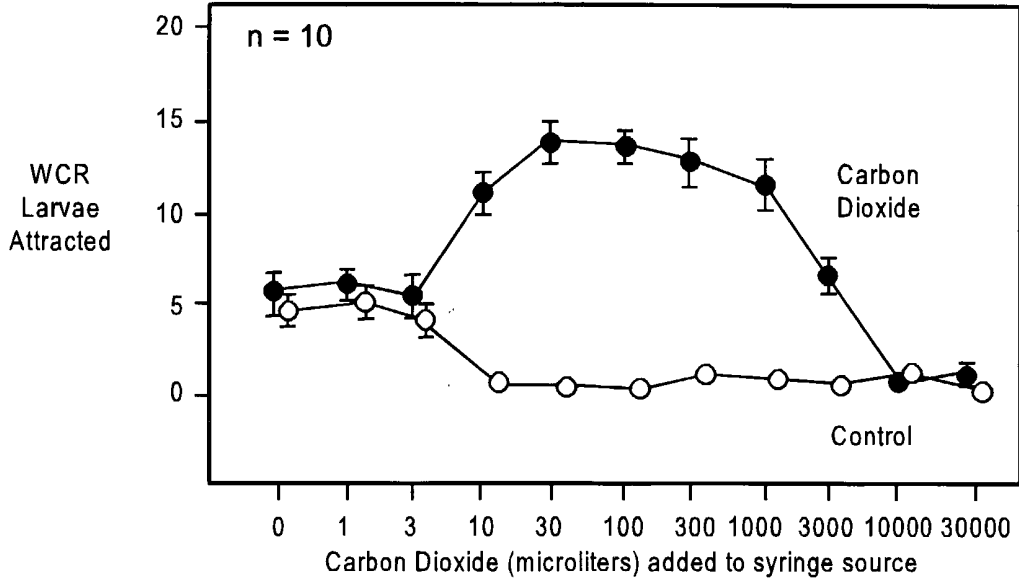

GRAPH 18-4B

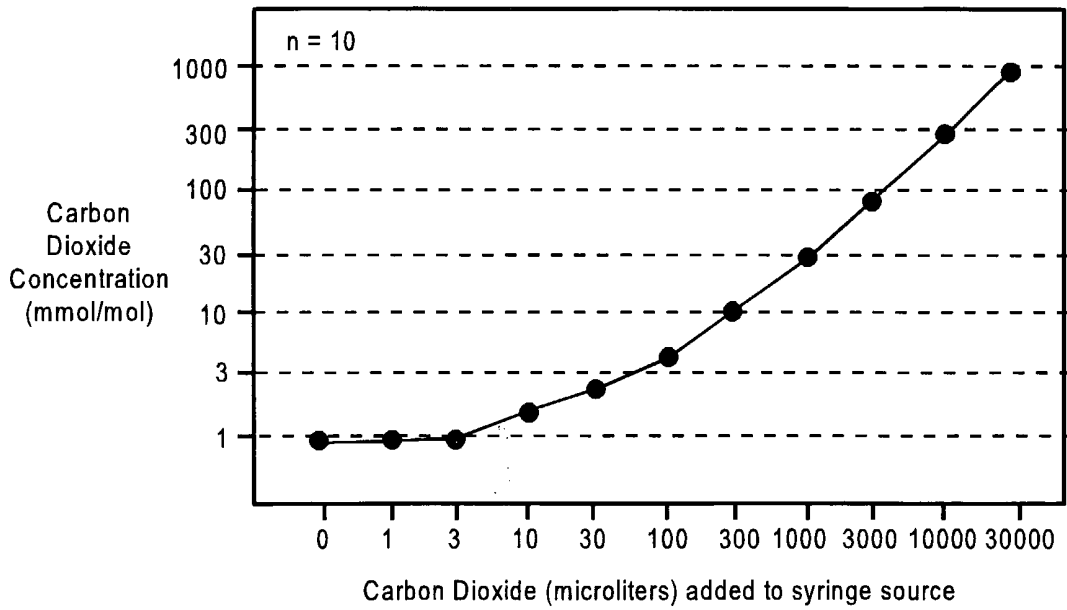

GRAPH 18-5A

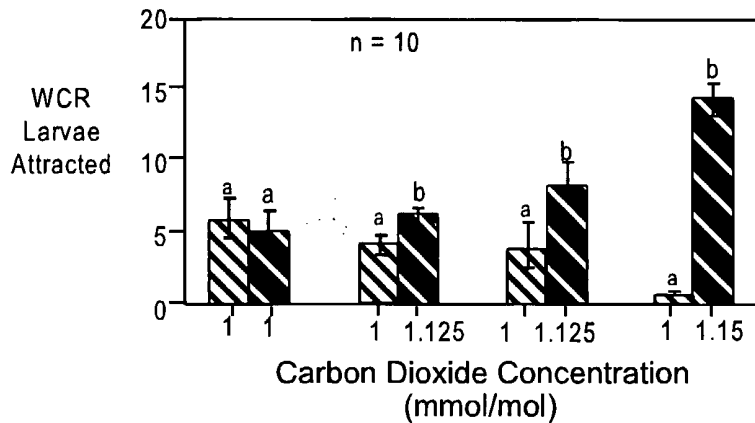

GRAPH 18-5B

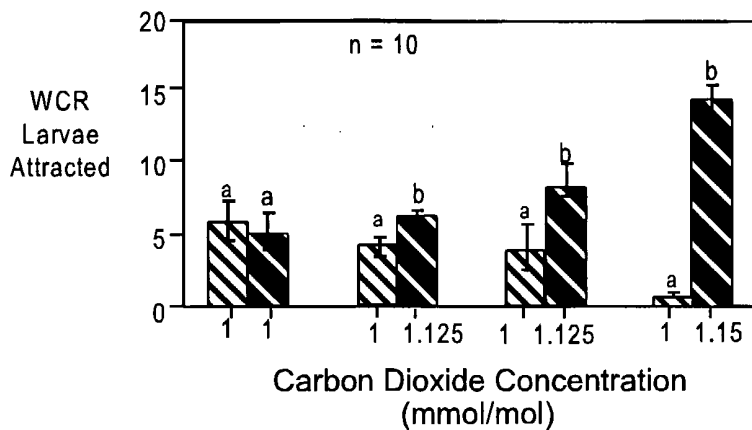

GRAPH 18-5C

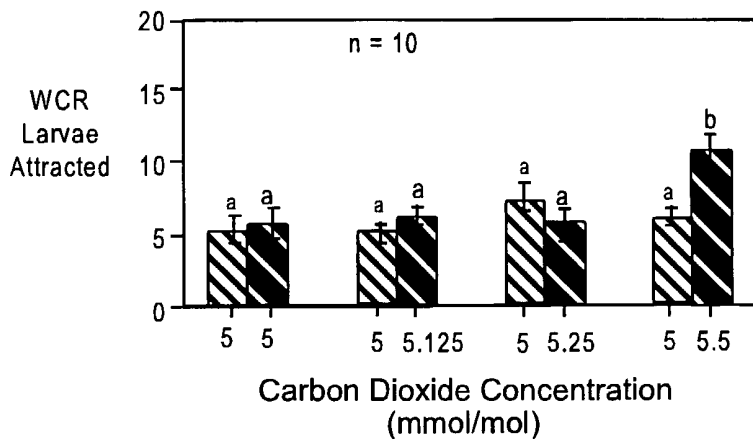

GRAPH 18-5D

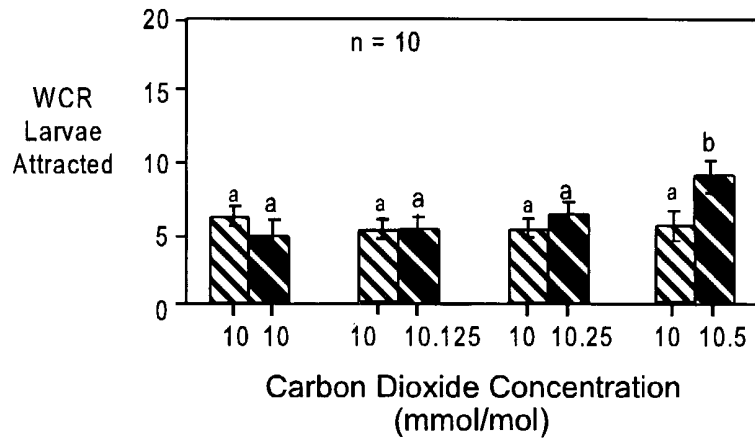

GRAPH 18-5E

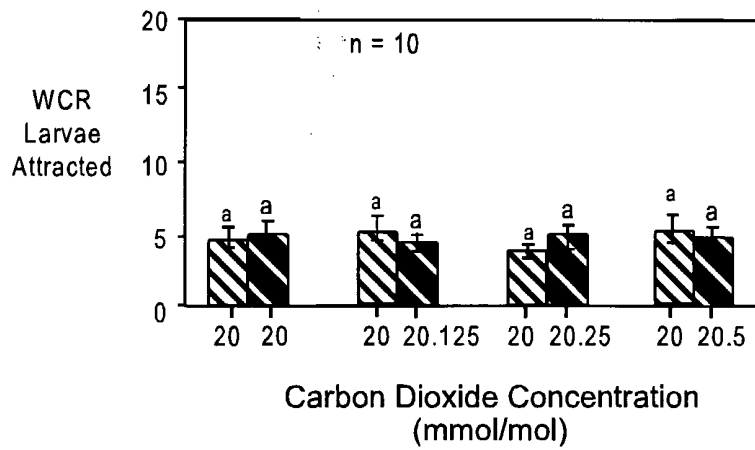

GRAPH 18-6A

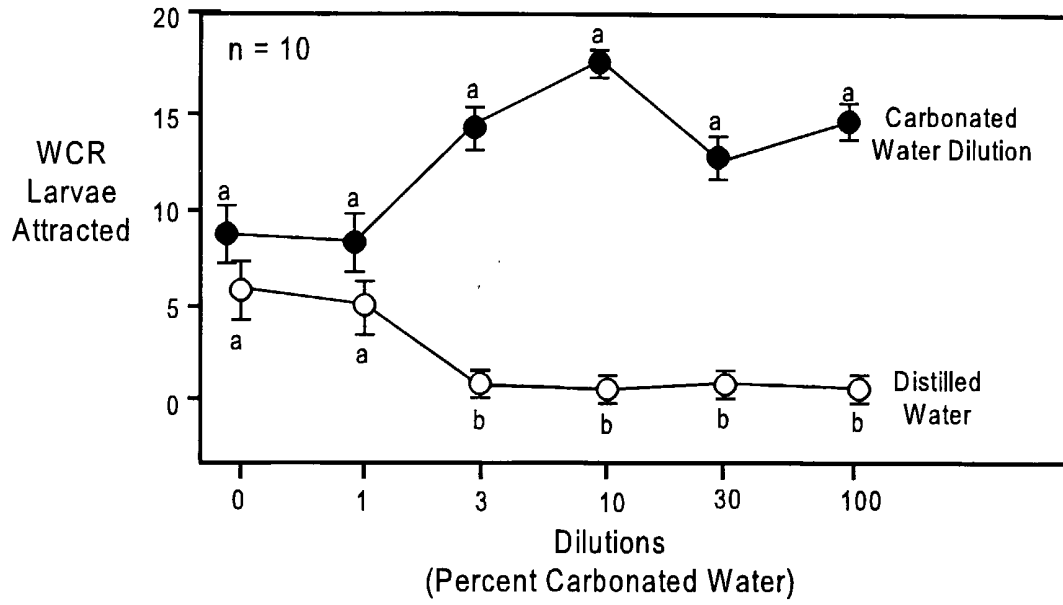

GRAPH 18-6B

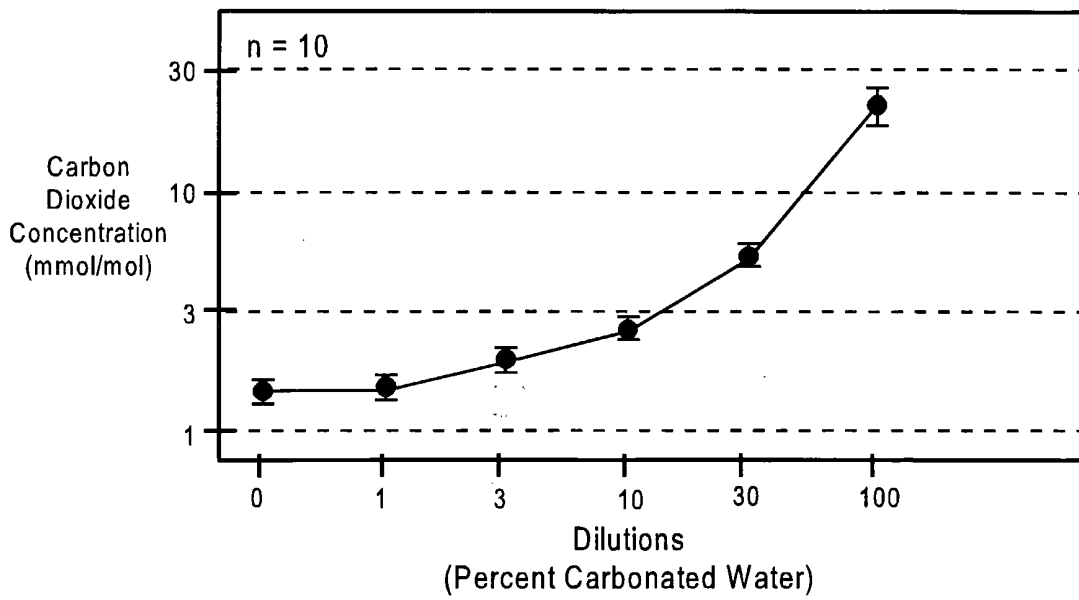

GRAPH 18-7A

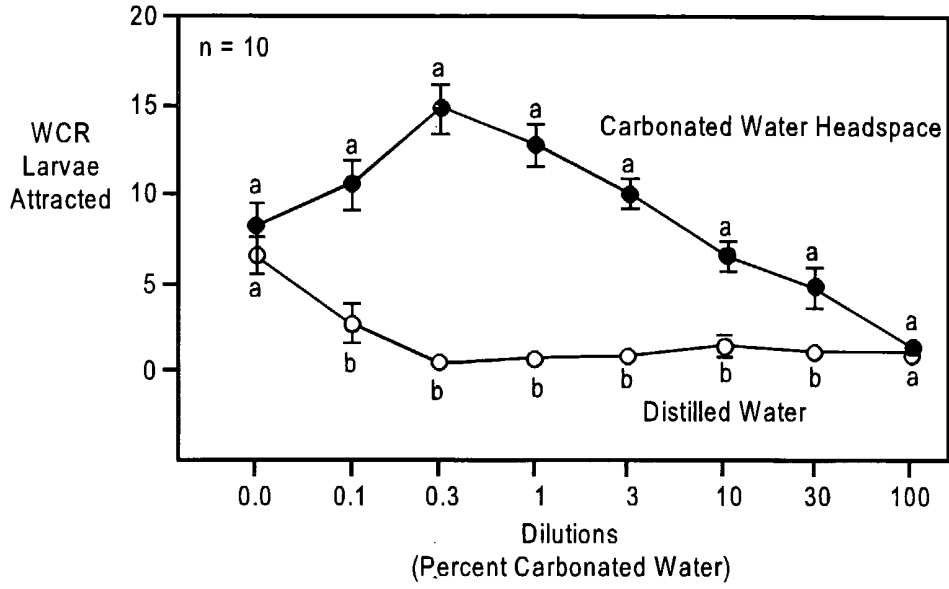

GRAPH 18-7B

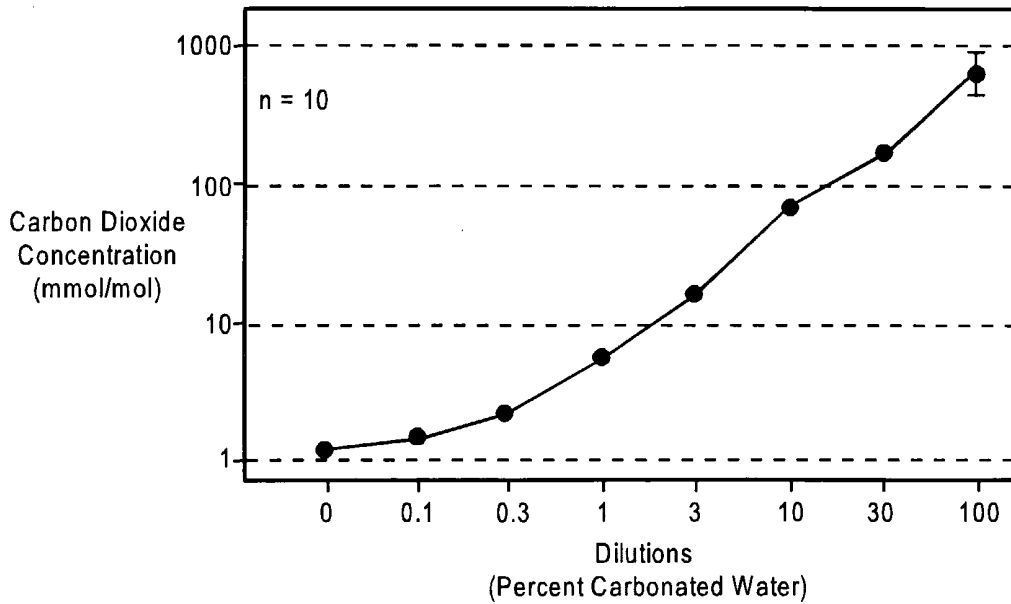

GRAPH 18-8A

Shell Vial Sources

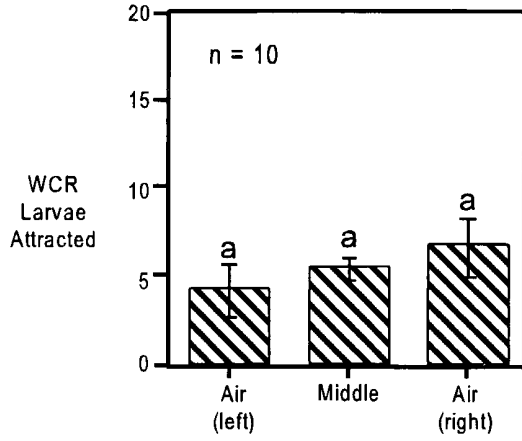

GRAPH 18-8B

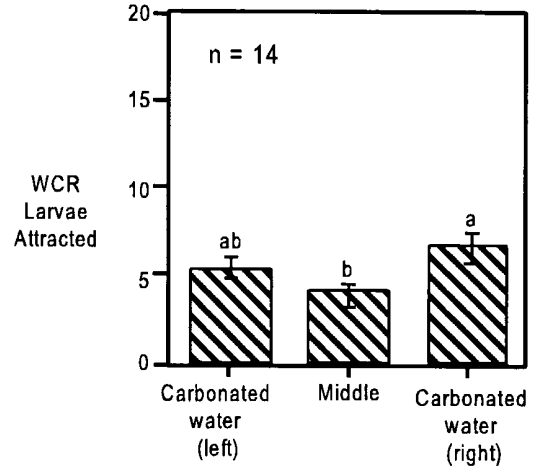

GRAPH 18-8C

Syringe Sources

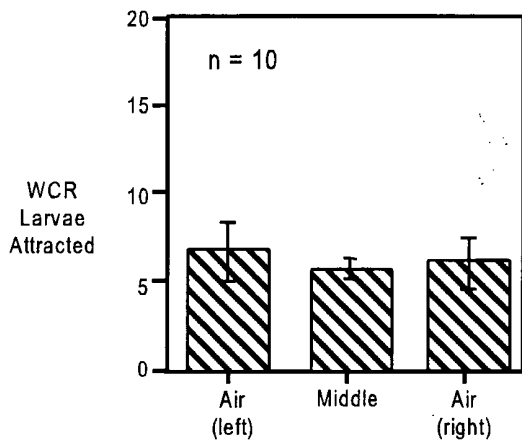

GRAPH 18-8D

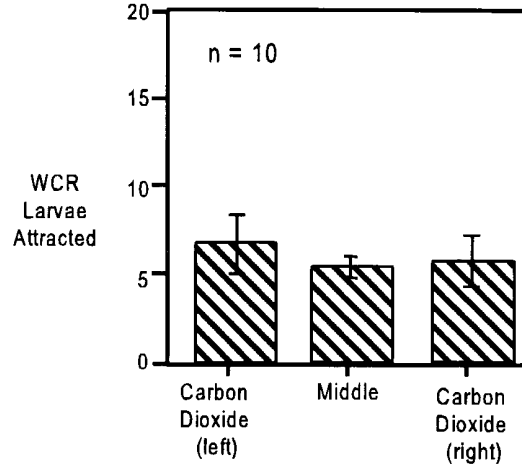

GRAPH 18-9

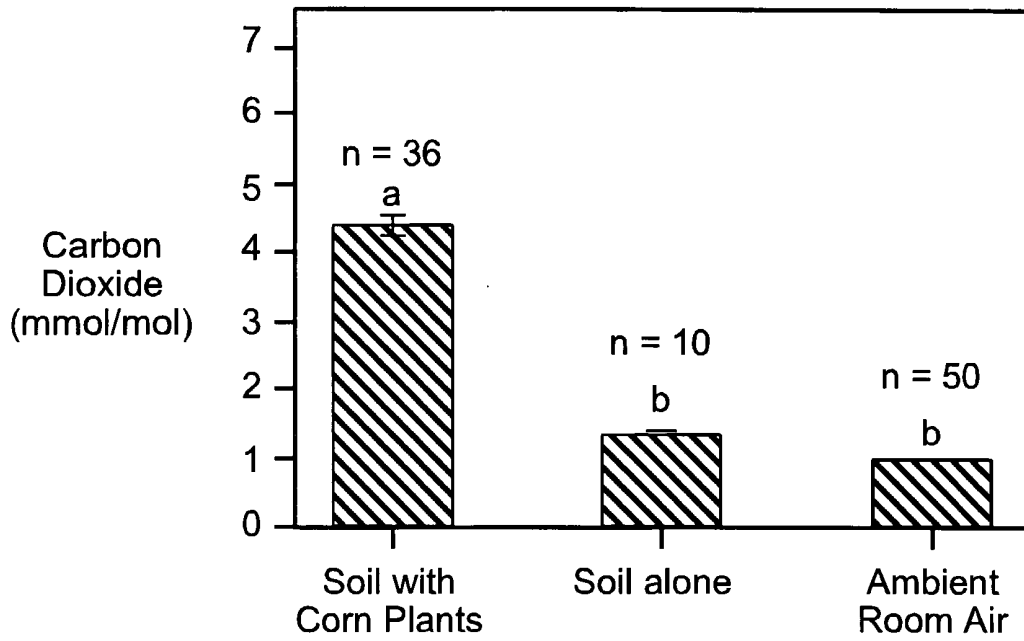

Example 19

In strong contrast to earlier published results, we now conclude that the attraction of western corn root worm, *Diabrotica virgifera virgifera* LeConte, larvae to corn roots is due to CO₂ alone, and that no other volatile chemical cues are involved in attracting the larvae. Choice test behavioral bioassays were conducted in the laboratory, with volatile corn compounds on 1 side of the bioassay apparatus and with different concentrations of CO₂ on the other side (mass spectrometry was used to measure CO₂ concentrations on both sides of the apparatus). Larvae were strongly attracted to volatile compounds from corn when ambient air was present on the other side of the bioassay. However, larvae chose equally between the 2 sides of the bioassay when volatile compounds from corn were present on 1 side and an equivalent concentration of CO₂ was present on the other side. When given a choice between corn volatiles and a higher concentration of CO₂, the larvae chose the CO₂ side significantly more often. In an experiment conducted both with diapausing and non-diapausing strains, the headspace from germinating corn seeds was collected and continuously injected into 1 side of the bioassay apparatus, and a defined concentration of CO₂ was continuously injected into the other side. We tested the possibility that compounds of limited volatility may be involved in larval attraction by preparing glass beads coated directly with volatiles produced by germinating corn seeds, and also by testing soil that was removed from corn roots. All these experiments indicated that compounds other than CO₂ were not involved in larval attraction. In other experiments, the soil atmosphere surrounding the roots of growing corn plants was not as attractive as an equivalent concentration of CO₂ alone, and the headspace from feeding-damaged corn roots was not as attractive as an equivalent concentration of CO₂ alone, indicating that weak repellents were present in these treatments together with the strong attractant CO₂. Tests with solvent extracts and cryogenic extracts of germinating corn seeds in conjunction with CO₂ also indicated the presence of weak repellents in corn for the larvae.

Western Corn Root Worm, *Diabrotica virgifera virgifera* LeConte, a major pest of corn, *Zea mays* L., in the United States (Krysan and Miller 1986), is an oligophagous, soil-dwelling insect, which as larvae, feeds upon the roots of its host plants. Branson (1982) reported that western corn root worm larvae are attracted to the roots of both host and non-host plants, and he concluded that western corn root

worm larvae respond to non-specific primary metabolites (such as CO₂) produced by host plants, rather than host-specific secondary compounds. Strnad et al. (1986) reported that western corn root worm larvae are highly attracted to CO₂, which is given off by corn roots in the soil (Harris and Van Bavel 1957, Massimino et al. 1980, Desjardins 1985, Labouriau and Jose 1987). Other investigators have also demonstrated this attraction (Hibbard and Bjostad 1988, MacDonald and Ellis 1990, Strnad and Dunn 1990, Jewett and Bjostad 1996, Bernklau and Bjostad 1998).

Subsequent to this early work, a series of publications from our laboratory (Hibbard and Bjostad 1988, 1989, 1990; Bjostad and Hibbard 1992; Hibbard et al. 1994) reported that corn roots emitted a blend of CO₂, MBOA (6-methoxy-2-benzoxazolinone), and 3 long-chain fatty acids (stearic acid, oleic acid and linoleic acid), and that this blend of compounds was more attractive than equivalent amounts of CO₂ alone. However, later field tests showed these compounds to have little or no effect as attractants for insecticides (Hibbard et al. 1995).

We recently completed an extensive set of experiments indicating that most of our own previous results were incorrect. We have now concluded that MBOA, stearic acid, oleic acid, and linoleic acid are not involved in attraction of western corn root worm larvae, and that CO₂ is the only attractive volatile compound that attracts western corn root worm larvae to corn roots.

Our revised conclusions are based on work conducted with a new behavioral bioassay designed specifically to test the responses of 1st-instar western corn root worm larvae, the life stage that is of greatest ecological interest as far as host plant selection is concerned (our earlier publications were all based on work with 2nd instars). The new bioassay apparatus consists of a vertical glass Y-tube filled with glass beads. The Y-tube accommodates the geotropic tendency of the larvae by allowing them to make a choice between the downward arms, and the glass beads reproduce the thigmotactic cues available to larvae in their natural soil environment. A syringe pump is used to provide slow, consistent delivery of candidate compounds to the 2 sides of the apparatus. In addition, the glass bead apparatus can be adapted to facilitate the testing of a variety of chemical sources.

In initial experiments with our new bioassay apparatus, we found that larvae were equally attracted to the corn source and to the control when the CO₂ concentrations were equally matched on both sides. These results directly

contradicted our earlier work, and compelled us to reinvestigate the role of CO₂ and other volatile compounds in the attraction of western corn root worm larvae.

Materials and Methods

5 **Insects.** Western corn root worms (originally obtained from J. Jackson, USDA-ARS Laboratory, Brookings, South Dakota) (non-diapausing strain) were reared on corn plants grown in soil in an incubator using methods described by Jackson (1985) and modified by Hibbard and Bjostad (1988). Periodic additions were made to the colony with eggs obtained from French Agricultural Research
10 (Lamberton, MN). Eggs from a diapausing strain of western corn root worm were obtained from French Agricultural Research. The eggs (in soil) were kept moist and larvae were used in bioassays within 12 h of hatching.

Corn. Untreated, dried corn seeds (*Zea mays*, cv 3055 provided courtesy of Gary D. Lawrance, Pioneer Hi-Bred International, Inc., Johnston, Iowa) were washed
15 with soapy water, soaked for 24 h in soapy water (1 drop of Ivory Dishwashing Liquid, Procter & Gamble, Cincinnati, OH, per liter of water), and rinsed thoroughly with water. For use in bioassays, the washed seeds were germinated 3 d on germination paper (Steel Blue, Anchor Paper Company, St. Paul, MN) in a closed polyethylene tub (30 by 15 cm), and the plants typically reached a shoot length of 1
20 cm and a root length of 6 cm.

Soil. Soil was obtained from a local agricultural research farm whose history was known, and where no corn had been grown for 5 years.

Bioassay Procedure. All bioassays were choice tests conducted using a vertical glass "Y" tube apparatus filled with 3-mm glass beads (Bernklau and Bjostad
25 1998) (Graph 19-1-A). Volatile compounds were prepared in 35-ml polyethylene syringes (cat no. 106-0490, Sherwood Medical, St. Louis, MO) and a syringe pump (Sage Model 355, Fisher Scientific, Pittsburgh, PA) was used to provide, slow (1 ml per min) consistent delivery of the compounds into each choice arm of the bioassay apparatus. Twenty newly-hatched larvae (less than 12-h-old) were used for each
30 bioassay. Non-diapausing larvae were used for all experiments unless otherwise indicated below. For each choice test a minimum of 10 replicates were conducted.

GC-MS Analysis of CO₂. Mass spectrometry was used to determine CO₂ concentrations. A Hewlett-Packard Series II 5890 gas chromatograph interfaced with

a Hewlett-Packard 5971 mass selective detector was operated in selected ion monitoring mode (SIM) for m/e 44 with a methyl silicone capillary column (30 m by 0.32 mm inside diameter, RSL-150, Alltech, Deerfield, MI). A 2-microliter sample of the headspace was taken from 2 cm inside the polyethylene syringes.

5 **Corn Headspace Versus CO₂.** Using the glass bead bioassay (Bernklau and Bjostad 1998) the headspace over germinating corn seeds was tested in a choice test against a series of CO₂ concentrations to determine if corn volatiles (including CO₂) were more attractive to the larvae than CO₂ alone. A 35-ml syringe was filled with the headspace over 3-d-old germinating corn seedlings by means of a 25-cm length of
10 slender Teflon tubing inserted into a hole drilled into the cover of the tub containing the corn seedlings.

Three different concentrations of CO₂ were tested on the control side of the choice test. In the 1st test, we used ambient room air on the control side, which contains a lower concentration of CO₂ than the corn headspace (approximately 1.0
15 mmol/mol). In the 2nd test, we used GC-MS-SIM to match the CO₂ concentration in the syringe on the control side to be equal to that measured in the syringe containing corn headspace. In the 3rd test, the syringe on the control side of the choice test contained a CO₂ concentration twice that measured in the corn headspace. To prepare
20 each of these control concentrations, a 2nd 35-ml polyethylene syringe was partially filled (approximately 5 ml) from a tank containing pure (100%) CO₂ using a glass syringe. Headspace from a plastic tub containing only moist germination paper was drawn into the syringe to fill it, mixing the air and CO₂ thoroughly at the same time. The gas mixtures in the polyethylene syringes were allowed to equilibrate for 15 min, and GC-MS-SIM was used to verify the CO₂ concentrations in both syringes prior to
25 each bioassay.

Corn Headspace Versus CO₂ with Diapausing Larvae. The larvae used in our studies were from a colony of nondiapausing western corn root worm that has been maintained in our laboratory since 1986. We wished to determine if diapausing western corn root worm larvae would respond differently to corn volatiles than the
30 colony larvae. Using the same method described above, the headspace over germinating corn seeds was tested in a choice test against a series of CO₂ concentrations with western corn root worm larvae from a diapausing strain.

Corn Headspace-Coated Glass Beads versus CO₂. In the previous experiments, corn volatiles were introduced into the bottom of the Y-tube and carried through the glass beads by the airstream from the syringe pump. We also tested the possibility that some volatile compounds may have been removed from the airstream by coating out on the glass beads on the bottom of the Y-tube where they would not be available for the larvae to detect at the choice point near the middle of the Y-tube. For these tests, 2 glass tubes (4 cm long, 8 mm inside diameter, restricted at the bottom to support the glass beads) were wrapped with Teflon tape and fitted snugly inside each branch of the Y-tube. A Teflon connector was fitted over the bottom end of each tube, a NMR cap was then inserted tightly inside the connector, and both tubes were filled with glass beads. One filled glass tube was inserted 2 cm into the bottom of a plastic tub containing 3-d-old germinating corn seeds. A 25-cm length of Teflon tubing was inserted into the hole in the NMR cap and the other end was connected to a 35-ml polyethylene syringe. The plunger was slowly drawn out, pulling the corn headspace through the glass beads and filling the syringe. The glass tube was then removed from the corn tub, the top was capped with a rubber stopper, and the bottom was sealed with a metal plug inserted into the hole in the NMR cap. For the control side of the bioassay, a 35-ml polyethylene syringe was filled with 1 of 3 concentrations of CO₂, as described previously (ambient CO₂, CO₂ matching the concentration in the headspace over the germinating corn seeds, or twice the concentration of CO₂ in the corn headspace). The gas mixture from 1 of the syringes was pushed through a glass test tube filled with glass beads through a 25-cm length of Teflon tubing inserted into a hole in the rubber stopper capping the top. The hole in the NMR cap was sealed with a wire plug. The glass tubes containing corn headspace or 1 of the CO₂ controls were uncapped and inserted into the ends of the Y-tube so that the tops were even with the junction of the 'Y'. With this arrangement, corn compounds of limited volatility were available to the larvae at the choice point. The rest of the Y-tube was filled to within 0.5 cm of the top with untreated glass beads. The syringe containing corn headspace and the 2nd syringe containing a CO₂ mixture were connected to the ends of the Y-tube with 25-cm lengths of Teflon tubing inserted into the hole in the NMR cap. The CO₂ concentrations in both test tubes and in the 2 remaining polyethylene syringes were verified using GS-MS-SIM prior to each bioassay.

Headspace from Corn in Soil Versus CO₂. We considered the possibility that microorganisms and other components of the soil environment may interact with growing corn roots to produce volatile compounds that attract western corn root worm larvae, and that they may not be present in corn that is germinated outside of soil. Using the method described above, the headspace obtained from soil that contained growing corn plants was tested against different concentrations of CO₂ to determine if such volatiles attract western corn root worm larvae. The bottom of a glass dessicator (Cat No. 25031-026, VWR Scientific, Denver, CO) (20 cm high, 25 cm diameter) was filled with water (3 cm deep). A perforated ceramic plate (suspended 6 cm from the bottom) was lined with filter paper (Whatman No. 4, 15 cm diameter, Cat No. 1004-090, Springfield Mill, Maidstone, Kent, England). Two 35-cm pieces of slender Teflon tubing were secured on top of the filter paper with sewing thread tied through the holes in the plate. The filter paper and tubing were covered with 2 cm of a 4:1 soil/peat moss mixture, and the soil was then moistened with 40 ml of water. Untreated, dried corn seeds (50) that had been washed with soapy water, soaked for 24 h, and rinsed thoroughly, were evenly spread over the soil and covered to a depth of 1 cm. The cover of the dessicator was replaced. The Teflon tubes were secured with cellophane tape to the sides of the chamber so that they projected out the hole (4 cm diameter) in the cover. When the plants were 8 d old, 35 ml of the soil headspace was drawn into a 35-ml polyethylene syringe through the 35-cm Teflon tubes. A 2nd 35-ml polyethylene syringe was filled (as described above) with 1 of 3 concentrations of CO₂ (ambient CO₂, CO₂ matching the concentration in the headspace over the damaged corn seeds, or twice the concentration of CO₂ in the soil headspace). The gas mixtures in the polyethylene syringes were allowed to equilibrate for 15 min, and GC-MS-SIM was used to verify the CO₂ concentration in both syringes prior to each bioassay.

Soil Bioassay. A variation of the bioassay apparatus containing soil was used to test larval attraction to corn compounds of limited volatility that might be present in soil in which corn is grown. Washed, soaked corn seeds (9) were planted in a plastic tub (11 cm high, 7 cm diameter) in soil that had been sifted through a 0.32 mm mesh and through a 5 mm mesh screen (W.S. Tyler Inc., Mentor, Ohio 44060). An equal amount of soil was added to a 2nd tub as a control. Both tubs were uncovered after 3 d and the soil was used for bioassays when the corn plants were 8 d old. The

corn plants were removed from the soil and the soil was examined under a microscope to remove any pieces of corn roots that might remain. The bottom of a glass test tube (4 cm long, 8 mm diameter, with a 1.5 mm hole in the bottom) was lined with a square (1 by 1 cm) of organza cloth and the tube was filled with the soil. A Teflon connector was snugly fitted over the bottom end of the tube and a NMR cap (with a 1-mm diameter hole) was inserted tightly inside the connector. A 2nd glass test tube was prepared, using soil from the control tub. The 2 glass tubes were inserted snugly inside the glass Y-tube so that the tops were even with the junction of the 'Y', and the rest of the Y-tube was filled to within 1 cm of the top with soil from the corn tub. A 60-ml polyethylene syringe containing a 5 mmol/mol mixture of CO₂ (prepared as described above) was connected to the side of the Y-tube containing corn soil via a 25-cm length of Teflon tubing inserted into the hole in the NMR cap. A 2nd 60-ml polyethylene syringe was filled (as described above) with 1 of 3 concentrations of CO₂ (1, 5 or 10 mmol/mol CO₂) and connected to the control side of the Y-tube. GC-MS-SIM was used to verify the CO₂ concentration in both syringes prior to each bioassay. Bioassays were run for 60 min.

Corn Headspace From Western Corn Root worm-Damaged Corn Versus CO₂. Using the same method described in the 1st experiment, the headspace over germinating corn seeds that had been fed upon by western corn root worm larvae was tested against CO₂ to determine if larval feeding causes corn roots to produce volatile compounds that are more attractive to western corn root worm larvae than those from undamaged roots. Corn seeds were germinated in covered plastic tubs as described above. After 3 d, 80 2nd-instar western corn root worm larvae were transferred onto the roots of the germinating corn seeds, the container was closed and the larvae were allowed to feed for 24 h. A 35-ml polyethylene syringe was filled with the headspace containing the corn volatiles from the damaged corn, and a 2nd 35-ml polyethylene syringe was filled with 1 of 3 concentrations of CO₂ (ambient CO₂, CO₂ matching the concentration in the headspace over the damaged corn seeds, or twice the concentration of CO₂ in the corn headspace). The gas mixtures in the polyethylene syringes were allowed to equilibrate for 15 min, and GC-MS-SIM was used to verify the CO₂ concentration in both syringes prior to each bioassay.

Corn Surface Extracts. Surface extracts of germinating corn seeds were tested for larval attraction. Germinating corn seeds (3-d-old, 50 grams dry wt as

determined at the end of the experiment) were firmly packed into a glass tube (30 cm long, 30 mm diameter, tapering to 12 mm diameter) and diethyl ether (glass-distilled) was dribbled through the seedlings until 8 ml of extract had been collected. The extract was concentrated to 2 ml by evaporation with a gentle stream of nitrogen. Different aliquots of the extract (0.003, 0.03, 0.1, 0.3, 3.0, and 30 gram equivalents corn) were applied to a strip of filter paper (Whatman no. 5, 0.5 by 2 cm) and an equal volume of control solvent, concentrated similarly, was applied to another strip of filter paper. After the solvent had evaporated, the strips were placed in the glass connection tube on the end of either branch of the Y-tube and the NMR cap was replaced. The bioassay was conducted as described above with equal concentrations of CO₂ (3 mmol/mol) in the syringes on both sides.

Cryogenic Collections of Corn Volatiles. Germinating corn seeds (3-d-old, 50 grams dry wt as determined at the end of the experiment) were packed into a glass tube (30 cm by 30 mm, tapering to 12 mm). A strip of filter paper (0.5 by 2 cm) and a boiling chip were placed in the bottom of a glass sample tube (12 mm by 35 cm, closed at the bottom) and the sample tube was attached to the bottom of the seed-holding tube with a Teflon connector. For a control, a strip of filter paper and a boiling chip were placed in an empty sample tube. Both sample tubes were immersed in a liquid nitrogen bath (3.5 liters). As the air in the treatment tube condensed, a vacuum was created, which pulled air through the corn seedlings and down into the sample tube. When 2 ml of liquid air had collected in the treatment and control tubes, they were removed from the nitrogen bath, the treatment tube was disconnected from the corn seedling tube, and both tubes were placed into precooled (in liquid nitrogen) styrofoam blocks until the condensed air had boiled away. The filter paper strips were removed from the tubes and immediately inserted into the glass connection tubes on either side of the bioassay apparatus. Bioassays were conducted using the shell vial method (described above) with equivalent concentrations of CO₂ on both sides of the choice test.

Petri Dish Bioassay. The attraction of western corn root worm larvae to volatile compounds other than CO₂ was previously reported by our laboratory on the basis of experiments conducted using a petri dish bioassay apparatus (Hibbard and Bjostad 1988, 1989; Bjostad and Hibbard 1992). The results we have now obtained using the Y-tube apparatus conflict with these reports, and we conducted experiments

using the petri dish bioassay apparatus to re-investigate the results reported previously (Hibbard and Bjostad 1988). Three plastic petri dishes (5 cm diameter) were connected with 2-cm lengths of Teflon tubing (10 mm diameter) inserted into holes in their sides (Graph 19-6-A). Holes were cut with a brass tube attached to a soldering iron. The bottoms of the 2 end dishes had 12 mm holes melted through their centers. The apparatus was supported on a ring stand. Cryogenic collections of corn seedlings were prepared as described above, except that no filter paper strip was placed in the bottom of the collection tube. When the tube had warmed to room temperature, it was flushed for 10 sec with 100% CO₂ from a tank at 4 psi, then inverted for 30 sec. For the control side, an empty sample tube was similarly flushed with CO₂ for 10 sec and inverted for 30 sec. Immediately after inversion for 30 sec, each tube was capped and allowed to sit for 15 min to allow the CO₂ to equilibrate. The petri dish apparatus was assembled and a bubble level was used to insure that the apparatus was not tilted to 1 side or the other. When GC-MS-SIM measurements indicated that the CO₂ concentrations in the tubes were equal (measured through pinholes in the caps from within 5 cm of the top of the tubes) both tubes were connected with a Teflon connector to the holes in the bottom of the end dishes of the bioassay apparatus. The covers were placed on all 3 dishes and the apparatus was allowed to sit for 5 min to allow volatile compounds to begin diffusing. After 5 min, 10 2nd-instar western corn root worm larvae were placed in the center of the middle Petri dish and the cover was replaced. The number of larvae in each of the chambers and in the sample tubes was recorded every 5 min for a total of 30 min. All bioassays were conducted in dim lighting. CO₂ concentrations within the 3-petri-dish apparatus were measured by removing samples through a pinhole in each Teflon connector. A 5- μ l sample was taken from each side every 60 sec throughout the 30-minute period and analyzed using GC-MS-SIM. Twenty replicates of the behavioral bioassay were conducted, and CO₂ measurements were taken for 8 replicates.

Statistical Analysis. Analysis of variance was conducted for each experiment using orthogonal comparisons (Winer, 1971). In most of the experiments, corn volatiles were present on one side of the bioassay apparatus, and on the other side there was a defined CO₂ concentration that was equal to, greater than, or less than that on the corn volatile side. For each orthogonal comparison, a treatment was compared with its corresponding mean ($P = 0.05$), for both the CO₂ data and the behavioral data.

There were thus 3 orthogonal comparisons for the CO₂ data and also for the behavioral data from each of these experiments, with an experimentwise error rate of $P = 0.05$. The petri dish bioassay was analyzed similarly, except that 7 orthogonal comparisons were made, comprising the 7 bioassay intervals, for both the CO₂ data and the behavioral data. Means and standard errors are expressed as mean \pm standard error in the text that follows.

Results

Corn Headspace Versus CO₂. For the non-diapausing strain of western corn root worm, significantly more larvae ($P < 0.05$) chose the corn headspace side (Graph 19-1-B) when the control syringe contained ambient room air. There was no significant difference between the number of larvae that chose the corn headspace and larvae that chose the control when the CO₂ concentrations were the same (Graph 19-1-C). Larvae chose the control side significantly more often when the control contained twice the concentration of CO₂ as the corn headspace.

Corn Headspace Versus CO₂ with Diapausing Larvae. Similar results were obtained with the diapausing strain of western corn root worm. Significantly more of the larvae ($P < 0.05$) chose the corn headspace side when the control syringe contained ambient room air (Graph 19-1-D). There was no significant difference between the number of larvae that chose the corn headspace and larvae that chose the control when the CO₂ concentrations were the same (Graph 19-1-E). Larvae chose the control side significantly more often when the control contained twice the concentration of CO₂ as the corn headspace.

Corn Headspace-Coated Glass Beads Versus CO₂. Significantly more larvae ($P < 0.05$) chose the corn-coated beads and corn headspace side of the bioassay when the control side contained ambient room air (Graph 19-2-A). There was no significant difference between the number of larvae that chose the corn headspace and larvae that chose the control when the CO₂ concentrations were the same (Graph 19-2-B). Larvae chose the control side significantly more often when the control contained twice the concentration of CO₂ as the corn headspace.

Headspace from Corn in Soil Versus CO₂. The larvae chose the corn-coated beads and corn headspace significantly more often ($P < 0.05$) when the control syringe contained ambient room air (Graph 19-3-A). Significantly more larvae chose

the CO₂ control over the corn headspace when the CO₂ concentrations were the same (Graph 19-3-B). Larvae chose the control side significantly more often when the control contained twice the concentration of CO₂ as the corn headspace.

5 **Soil Bioassay.** The larvae chose the soil from growing corn roots significantly more often ($P < 0.05$) (Graph 19-4-A) when the syringe on the corn side contained a higher concentration of CO₂ than the control side (Graph 19-4-B). There was no significant difference between the number of larvae that chose the corn headspace and larvae that chose the control when the CO₂ concentrations were the same. Larvae chose the control side more often when the control contained twice the
10 concentration of CO₂ as the treatment side.

Corn Headspace From Western Corn Root worm-Damaged Corn Versus CO₂. The larvae chose the headspace from damaged corn seedlings significantly more often ($P < 0.05$) when the control syringe contained ambient room air (Graph 19-5-A). Significantly more larvae chose the CO₂ control over the corn headspace
15 when the CO₂ concentrations were the same (Graph 19-5-B). Larvae chose the control side significantly more often when the control contained twice the concentration of CO₂ as the corn headspace.

Corn Surface Extracts. There was no significant difference between the number of larvae choosing the corn extract and larvae choosing the control when
20 0.00, 0.003, 0.03, 0.1, 0.3 and 3.0 gram equivalents were tested ($P > 0.05$). When the treatment side contained 30 gram equivalents, the larvae chose the control side significantly more often ($P < 0.05$) than the corn.

Cryogenic Collections of Corn Volatiles. There was no significant difference between the number of larvae choosing the corn extract and larvae
25 choosing the control when 0, 1, 3, 10 and 100 germinating corn seedlings were cryogenically collected ($P < 0.05$), but the larvae chose the control side significantly more often ($P < 0.05$) than the volatiles collected from 300 germinating corn seedlings.

Petri Dish Bioassay. There was no significant difference between the
30 number of larvae that chose the cryogenic collection of corn volatiles and larvae that chose the control ($P > 0.05$) in the petri dish bioassay (Graph 19-6-B). During the 30 min that the bioassay was run, there was no significant difference between the CO₂

concentration on the corn side and the control side inside the petri dish apparatus (Graph 19-6-C).

Discussion

5 Our current experiments show that the attraction of western corn root worm larvae to corn roots is due to CO₂ alone, and that no other volatile chemical cues are involved. In an extensive series of choice tests with volatile compounds from germinating corn seedlings on 1 side of the choice tests and with different concentrations of CO₂ on the other side, the larvae were strongly attracted to volatile
10 compounds from corn that were presented on 1 side of the bioassay, when ambient air was present on the other side. However, larvae chose equally between the 2 sides of the bioassay when corn volatiles were present on 1 side and an equivalent concentration of CO₂ was present on the other side. Moreover, when corn volatiles were present on 1 side and a higher concentration of CO₂ was present on the other
15 side, most of the larvae chose the CO₂ side.

 Using the vertical Y-tube apparatus containing glass beads, a number of different approaches were tested. The headspace from germinating corn seeds was tested against 3 defined concentrations of CO₂ with diapausing and non-diapausing western corn root worm larvae. Volatiles from feeding-damaged corn roots were
20 used to test the possible production of attractive compounds by corn roots when they are under attack by western corn root worm larvae. Surprisingly, the larvae chose the control side slightly (but significantly) more often when an equivalent concentration of CO₂ was present on that side. It is possible that corn roots that are attacked by western corn root worm larvae respond by producing volatile compounds that are
25 slightly repellent to the larvae. We tested the atmosphere within soil that contained growing corn roots against the atmosphere within control soil to test the possibility that attractive compounds are produced by the interaction of corn roots with microbes in the soil. In this test, the soil atmosphere from growing corn roots was slightly repellent to the larvae. We tested the possibility that compounds of limited volatility
30 may be involved in larval attraction by preparing glass beads coated directly with volatiles produced by germinating corn seeds, and also by testing soil that was removed from growing corn roots in the Y-tube apparatus. There was no significant difference between the number of larvae choosing between the treatment and the

control in both experiments when the CO₂ concentrations were equal on both sides of the choice tests, indicating that compounds of low volatility are not involved in larval attraction.

Diethyl ether extracts of germinating corn seeds on filter paper were tested with equal concentrations of CO₂ on both sides of the choice test, and cryogenic collections of corn volatiles were tested in the same manner. In both tests there was no significant difference between the number of larvae choosing between the treatment and the control for all doses tested except for the highest dose, which was repellent.

In all of these experiments there was no indication that any compound other than CO₂ is involved in the attraction of western corn root worm larvae to corn roots. This conclusion is in stark contrast to results obtained previously in our laboratory. Employing a 3-petri-dish bioassay apparatus with 2ndinstar western corn root worm larvae, Hibbard and Bjostad (1989, 1990, 1994) isolated and identified 6-methoxy-2-benzoxazolinone (MBOA) as well as 3 long-chain fatty acids (stearic acid, oleic acid and linoleic acid) as attractants for western corn root worm larvae. Subsequent field tests showed these compounds to have little or no effect (Hibbard et al. 1995). To test rigorously any possibility that volatile compounds may be active in the attraction of western corn root worm larvae, we repeated the experiments previously done in our laboratory with the petri dish bioassay apparatus and cryogenic collections of corn volatiles. We followed the methods we used previously (Hibbard and Bjostad 1988, 1990) with 2 exceptions. First, we attached the petri dish apparatus to a foamboard base and used a small bubble level to insure that the apparatus was not tilted to 1 side or the other, because the larvae have a geotropic tendency. Second, we capped the sample tubes as soon as the liquid air had boiled away and used GC-MS-SIM to determine when the CO₂ concentrations in the tubes were equal. Using this approach, we observed much less variability in CO₂ concentrations than was present in our earlier work (Hibbard and Bjostad 1988). In these tests, the larvae chose equally between the corn volatiles and the control side, providing further corroboration that compounds other than CO₂ are not involved in larval attraction to corn.

One aspect of the present invention is the use of CO₂ to attract soil organisms (insects, nematodes, mites) away from their host plants or to confuse the organisms so that they are unable to locate the host plants. One source of CO₂ that might be used is

carbonated water. When used to irrigate the soil, carbonated water has been demonstrated to enrich the soil and increase the health and production of certain crops. Sources of CO₂ can also be used to attract soil-dwelling organisms to pesticide granules or to pellets containing a biocontrol agent. Under field conditions, sufficient

5 CO₂ gradients can be produced by granules of potassium bicarbonate co-formulated with an acid and a pesticide that are broadcast or incorporated into the soil. Organic sources can be used to achieve a slow release of CO₂ for control of soil organisms using various approaches. One approach is the co-encapsulation of yeast and a nutrient substrate with calcium alginate, or with k-carrageenan, which is less

10 expensive than calcium alginate. Calcium alginate co-encapsulation is relatively new technique in the fermentation industry that is currently used as a means for storage and dispersal of microorganisms, and has the potential to be employed in a variety of applications. Starch granules can also be used as formulations for microbial pesticides, and it is possible to incorporate chemical or biological sources of CO₂ into

15 these granules to attract and kill soil pests.

Figure Legends

Graph 19-1. (A) Glass bead bioassay apparatus with candidate chemical cues in syringes. (B) Choice test bioassay with syringe sources containing the headspace from germinating corn seedlings versus 3 different concentrations of CO₂ alone with larvae from a non-diapausing strain of western corn root worm. (C) CO₂ concentrations (measured with GC-MS-SIM) of headspace over germinating corn seeds and CO₂ mixtures in syringes for the choice tests with larvae from a non-diapausing strain of western corn root worm. (D) Choice test bioassay with syringe sources containing the headspace from germinating corn seedlings versus 3 different concentrations of CO₂ alone with larvae from a diapausing strain of western corn root worm. (E) CO₂ concentrations (measured with GC-MS-SIM) of headspace over germinating corn seeds and CO₂ mixtures in syringes for the choice tests with larvae from a diapausing strain of western corn root worm. Significant differences ($P < 0.05$) are indicated by different lower case letters. Bars represent standard errors.

Graph 19-2. (A) Choice test bioassay with syringe sources containing the headspace from germinating corn seedlings versus 3 concentrations of CO₂ alone and the glass beads on the treatment side coated with the volatiles from the corn headspace. (B) CO₂ concentrations (measured with GC-MS-SIM) of the headspace over germinating corn seeds and the CO₂ mixtures in syringes. Significant differences ($P < 0.05$) are indicated by different lower case letters. Bars represent standard errors.

Graph 19-3. (A) Choice test bioassay with syringe sources containing the atmosphere from soil containing growing corn plants versus 3 different concentrations of CO₂ alone. (B) CO₂ concentrations (measured with GC-MS-SIM) of the soil/corn headspace and the CO₂ mixtures in syringes. Significant differences ($P < 0.05$) are indicated by different lower case letters. Bars represent standard errors (for some treatments, the standard errors are too small to be visible on the graph).

Graph 19-4. (A) Choice test bioassay with soil removed from the roots of growing corn plants versus control soil. Syringe sources on the treatment side contain 5 mmol/mol CO₂ and the syringe sources on the control side contain 3 different concentrations of CO₂ alone. (B) CO₂ concentrations (measured with GC-MS-SIM) of the CO₂ mixtures in the syringes. Significant differences ($P < 0.05$) are indicated

by different lower case letters. Bars represent standard errors (all standard errors are too small to be visible on the graph).

5 **Graph 19-5.** (A) Choice test bioassay with syringe sources containing the headspace from germinating corn seedlings that have been fed upon by western corn root worm larvae versus 3 different concentrations of CO₂ alone. (B) CO₂ concentrations (measured with GC-MS-SIM) of headspace over western corn root worm-damaged corn seedlings and CO₂ mixtures in the syringes. Significant differences ($P < 0.05$) are indicated by different lower case letters. Bars represent standard errors.

10 **Graph 19-6.** (A) 3-petri-dish choice test bioassay apparatus. (B) Choice test bioassay with cryogenic collections of corn volatiles plus CO₂ versus CO₂ alone, using 2nd-instar western corn root worm larvae. (C) CO₂ concentrations (measured with GC-MS-SIM) taken from inside the bioassay apparatus. Significant differences ($P < 0.05$) are indicated by different lower case letters. Bars represent standard errors
15 (for some CO₂ measurements, the standard errors are too small to be visible on the graph).

GRAPH 19-1A

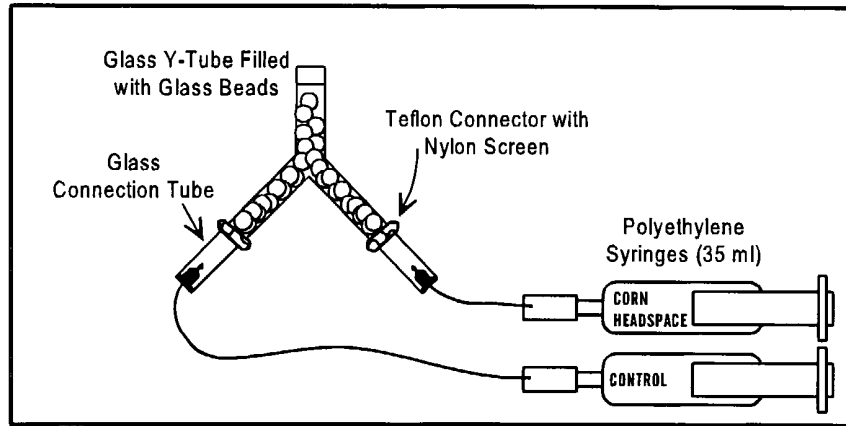

GRAPH 19-1B

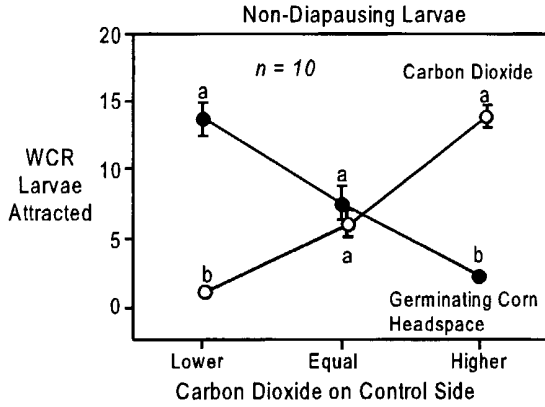

GRAPH 19-1C

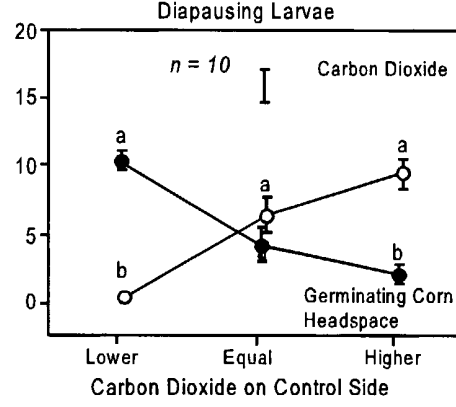

GRAPH 19-1D

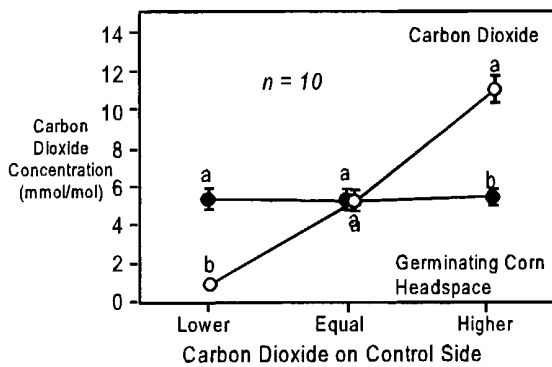

GRAPH 19-1E

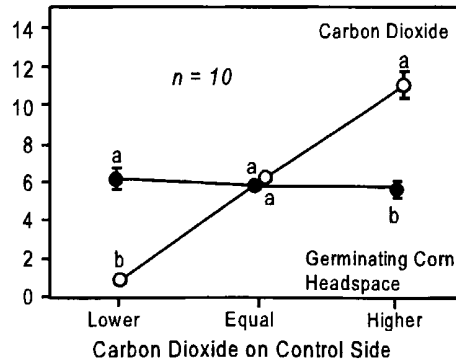

GRAPH 19-2A

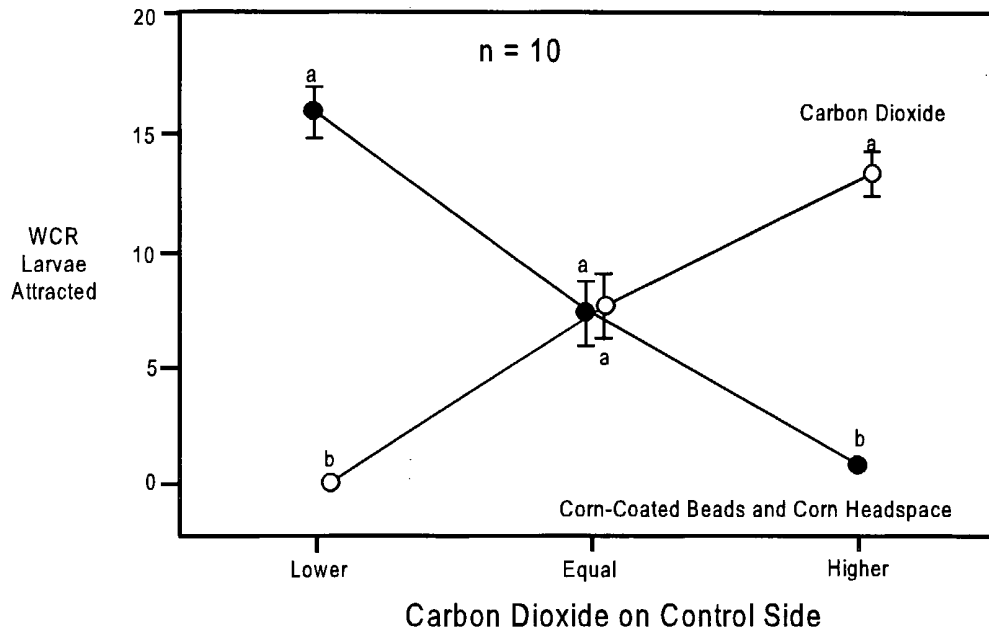

GRAPH 19-2B

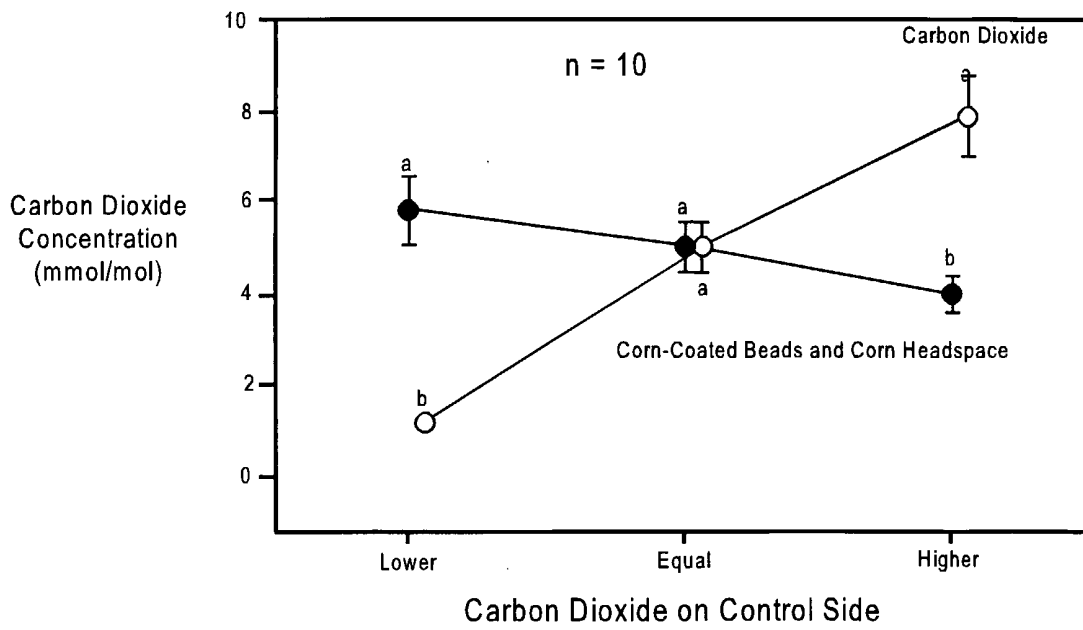

GRAPH 19-3A

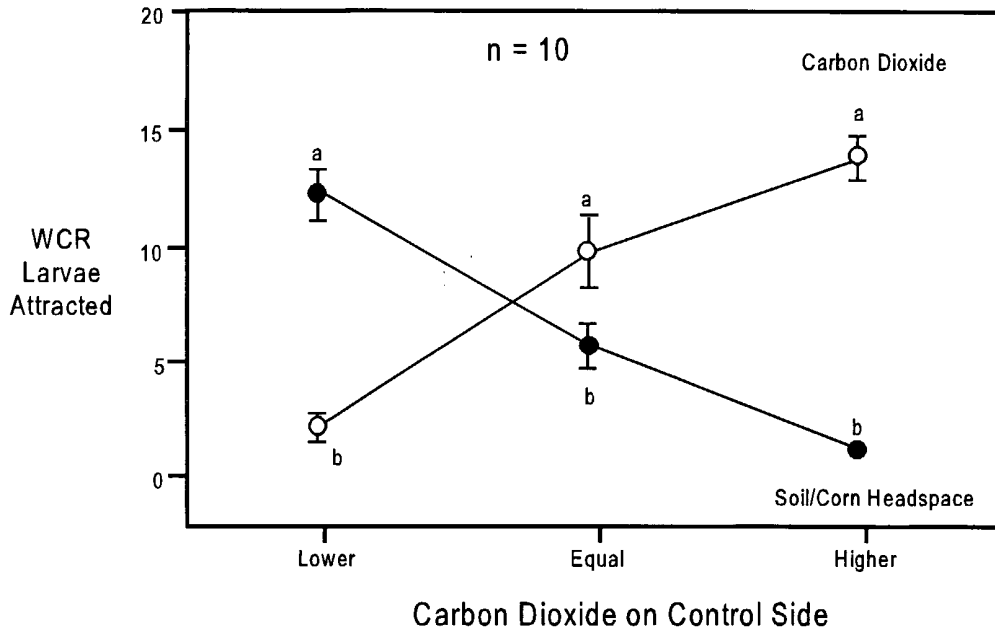

GRAPH 19-3B

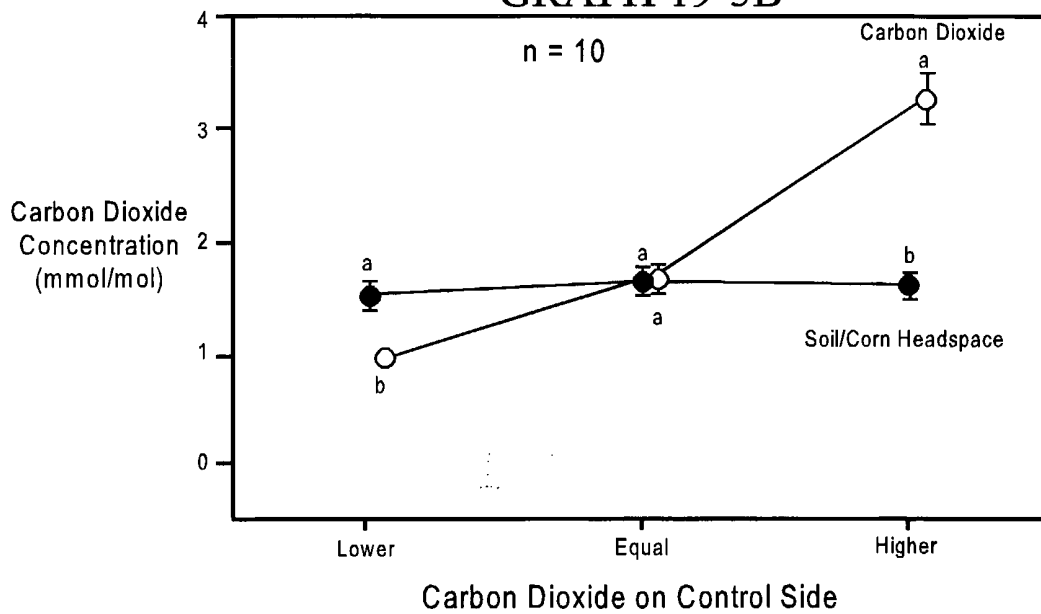

GRAPH 19-4A

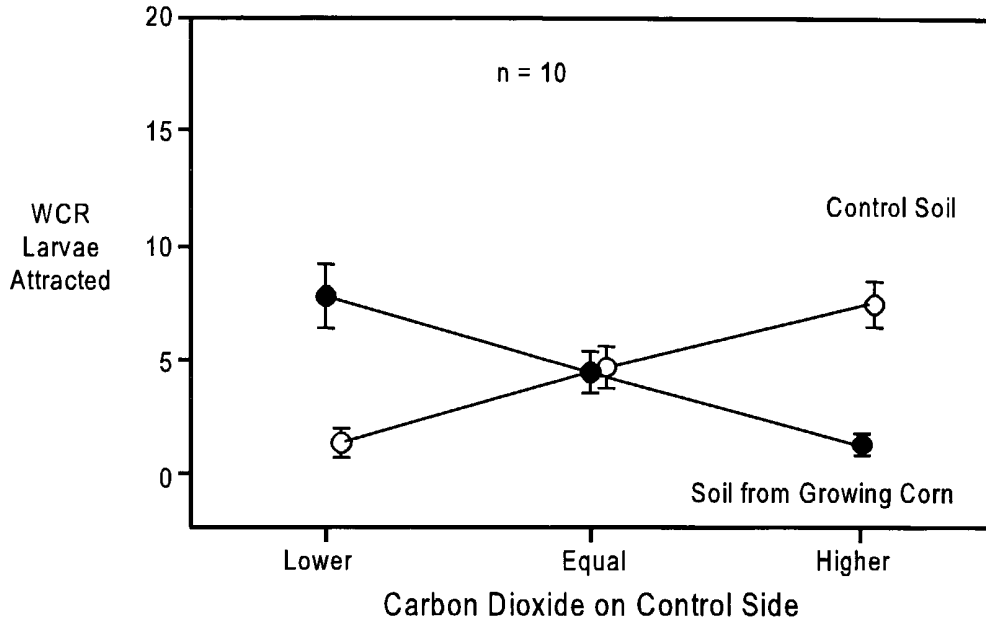

GRAPH 19-4B

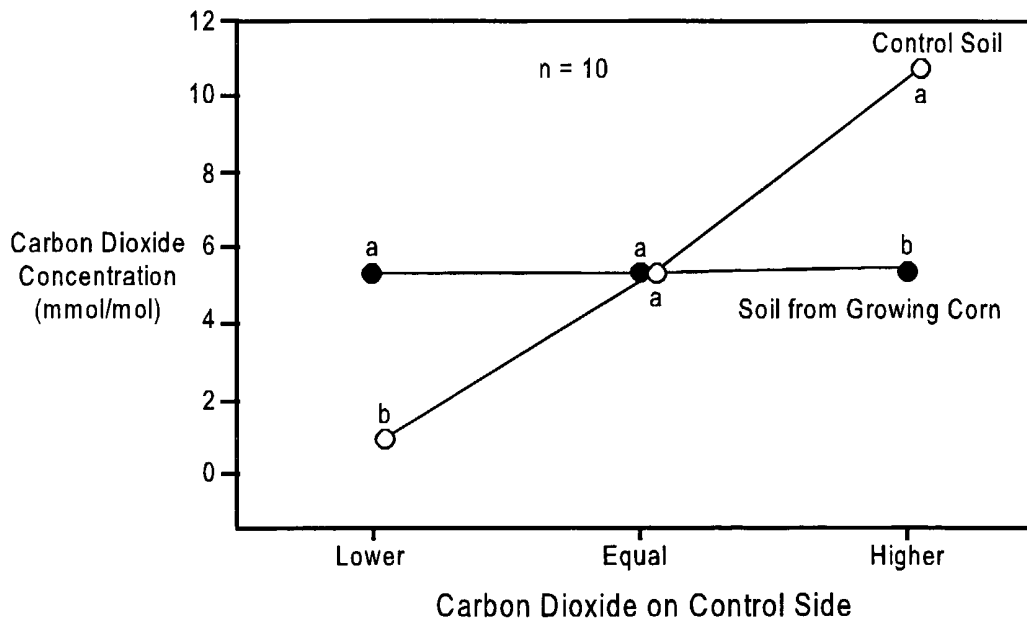

GRAPH 19-5A

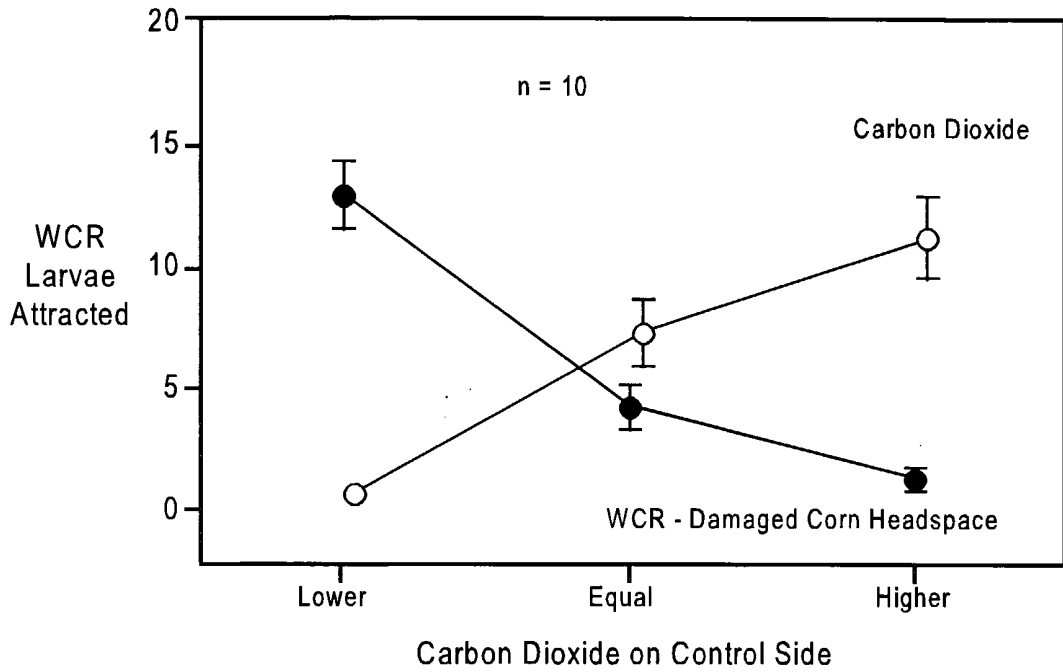

GRAPH 19-5B

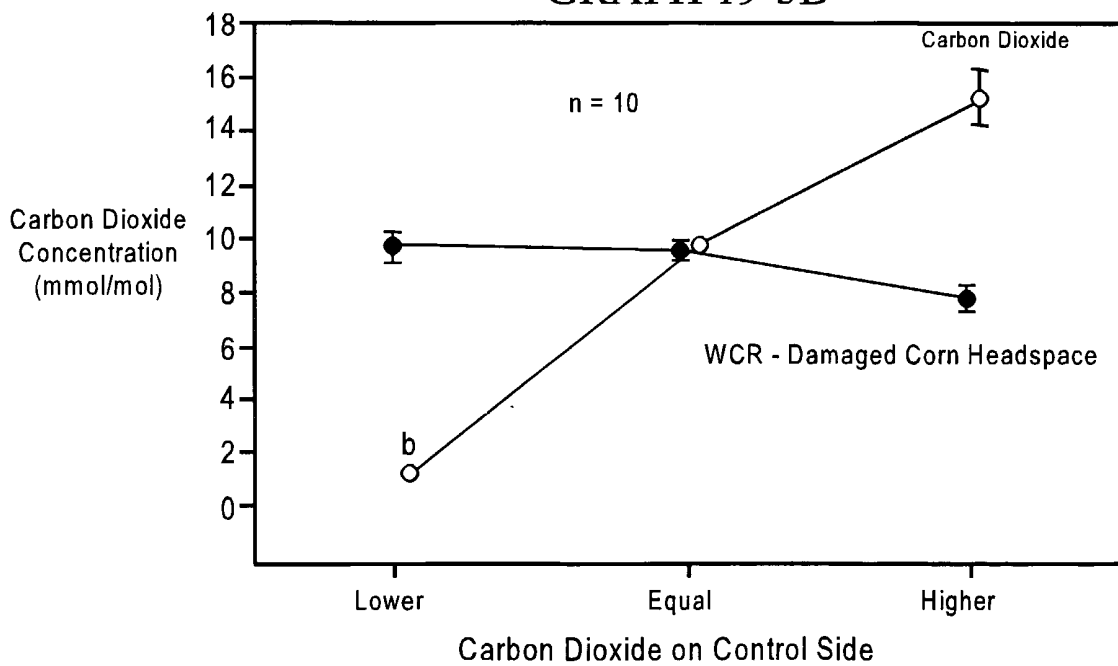

GRAPH 19-6A

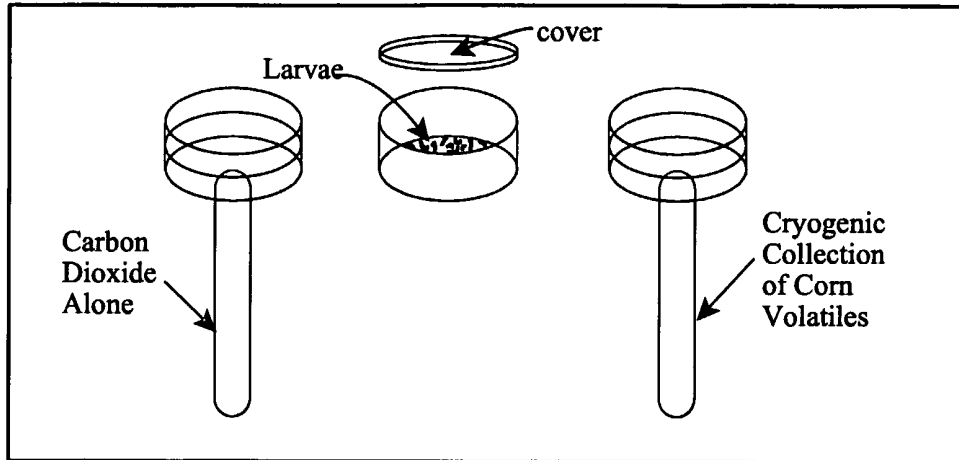

GRAPH 19-6B

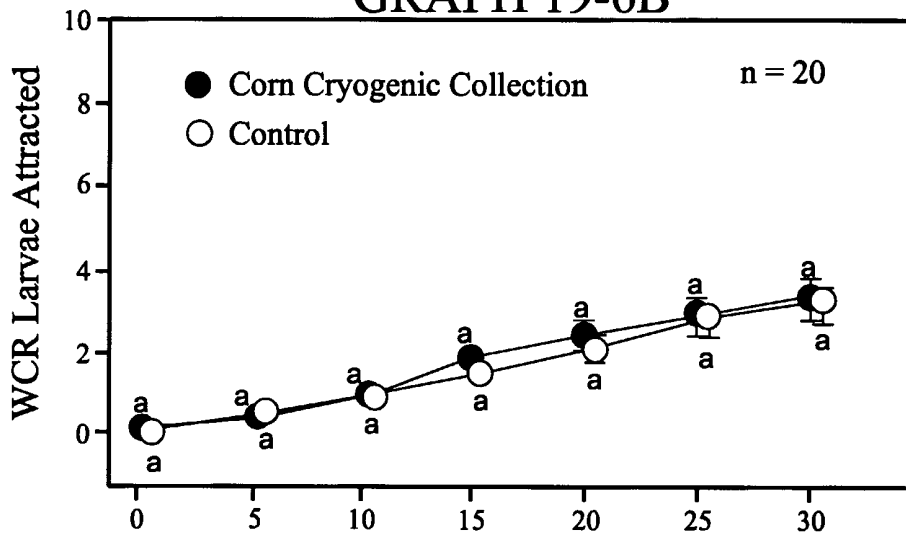

GRAPH 19-6C

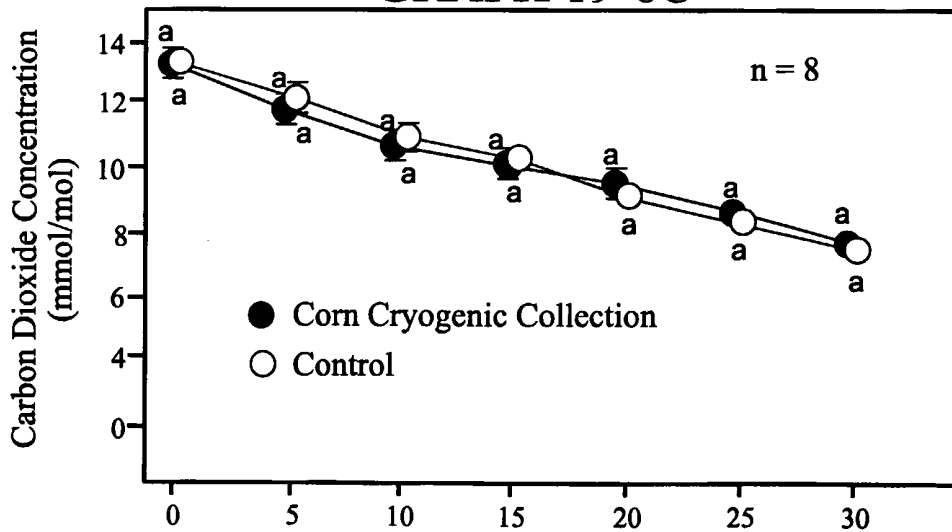

The data shown in the accompanying Graphs 20-23 support the appreciation that corn root worm larvae (*Diabrotica* species) are attracted to a granule which has a feeding stimulant and/or releases CO_2 .

5 These findings demonstrate that the control of corn root worm larvae provided by such attractant granules can be greatly improved by Thiamethoxam, a member of the Neonicotinoid class of insecticides. One reason for the uniqueness of this class of insecticides is their high level of efficacy at low rates. Another is that unlike the organophosphates used to control corn root worm, Thiamethoxam does not repel corn root worm neonate larvae (see Graph 20) in the presence of a feeding stimulus.

10 As seen in Graphs 21A and B the corn grit granule with a feeding stimulus and Thiamethoxam at 0.02 mg/gram of granule is highly efficacious when applied at 0.25 gram of granules/1 kg. of soil.

15 The bioassay comprises a laboratory test conducted in tubs (30 x 15 x 8 cm) filled with 3000 grams of soil. A single corn seed is placed 2 cm from one end of the tub. After the corn plant is 4 days old, 30 neonate Western Corn root worm larvae are introduced into the soil in the end of the tub opposite the corn seedlings. Larvae are given 24 hours to attempt to locate and attack the corn plant. Larvae are recovered from the corn plant.

20 For granule tests, a measured amount (0.25 gram of prepared granule is mixed into 1.0 kg. of soil (20% moisture). This soil is used to fill the center 1/3 of the bioassay tub.

25 Graph 22 shows a similar trial conducted with CO_2 and feeding stimulants in combination with various rates (10 mg. and 0.3 mg/g.) of CGA-29334 (Thiamethoxam). Graph 23 shows a larval bioassay in soil tubs using various increasing amounts of Thiamethoxam (e.g., CGA-293343). Other forms of attractants in addition to the CO_2 releasing agents as disclosed herein, can also be used in combination with insecticides and CO_2 attracting agents. Such compounds include, for example, pheromones, generally known by those of skill in the art, which can be used in combination with the present invention and therefore forms part of the present
30 invention.

GRAPH 20

WCR Larvae Staying on Paper

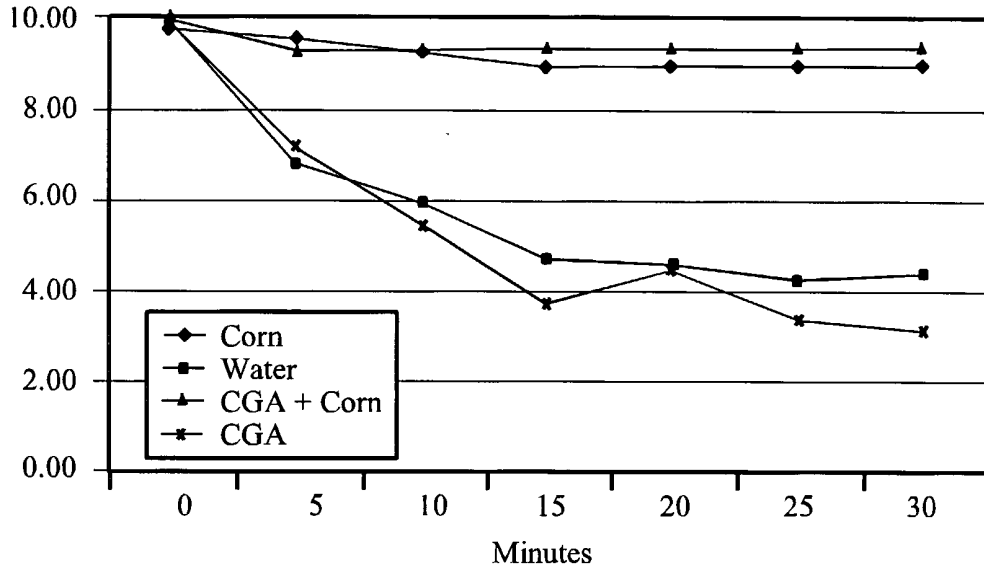

GRAPH 21A

Results of WCR Larval Feeding Bioassays with CGA293

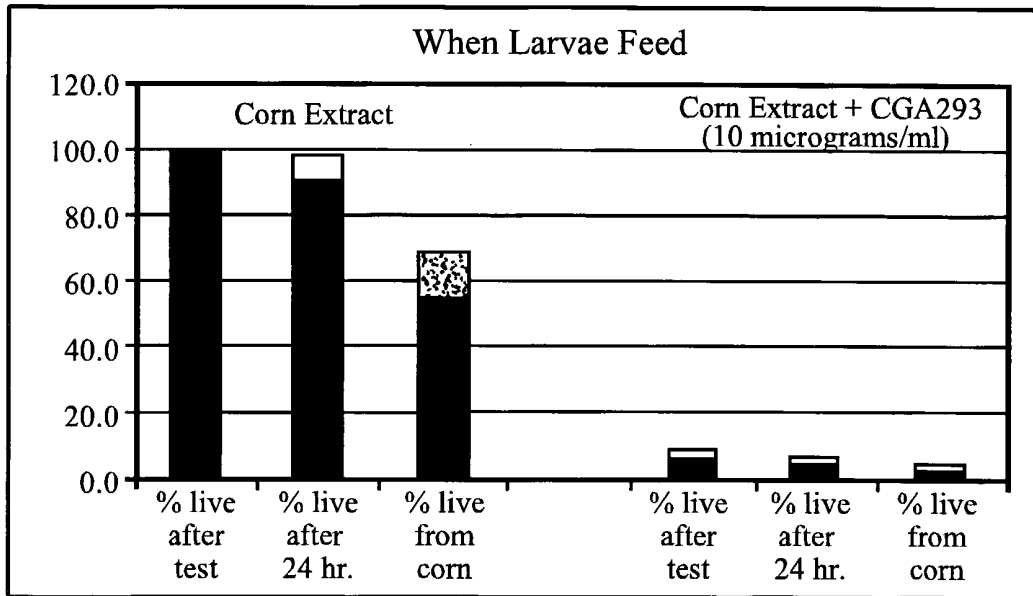

GRAPH 21B

Results of WCR Larval Feeding Bioassays with CGA293

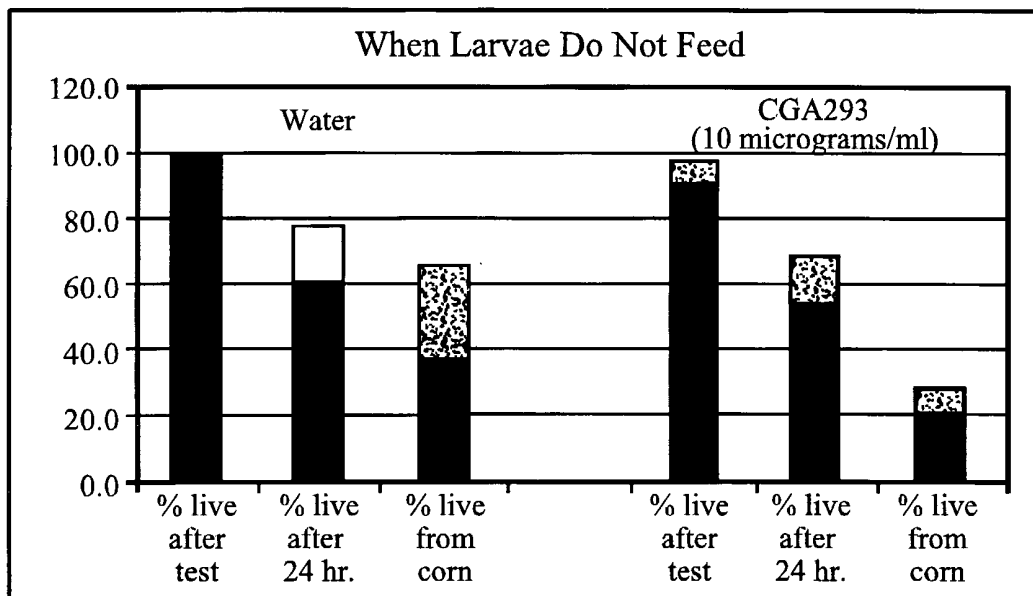

GRAPH 22

Granular formulation (1 gram) mixed into soil in center 1/3 of tub
 Rates of CGA-293343 are listed as (mg/g) - milligrams (A/1) per 1 gram granules

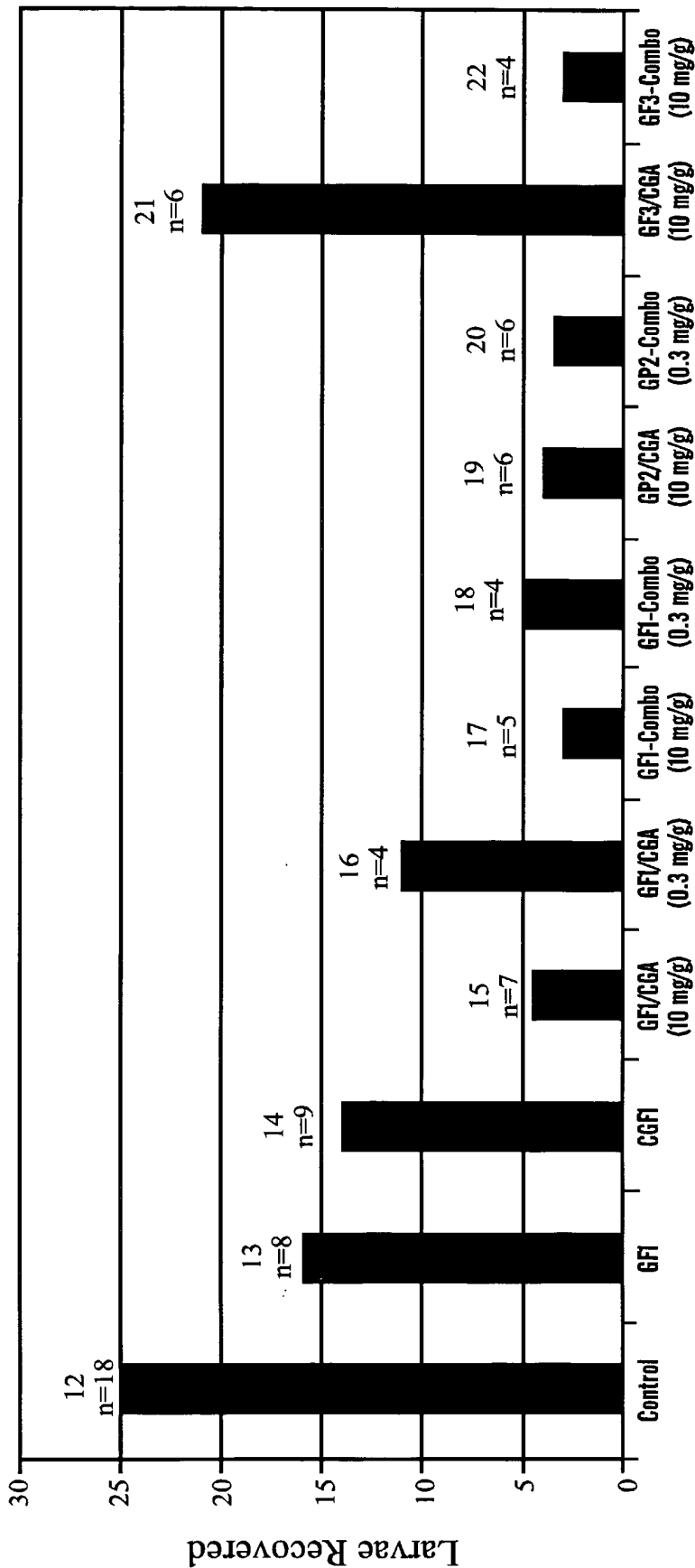

DEFINITIONS

- EFS - Extracted feeding stimulants
- GF - Granular formulation (CO2-generating)
- CGF - Granular formulation (CO2-generating) coated with feeding stimulants
- GF-CGA - Granular formulation (CO2-generating) coated with CGA-293343
- GF-Comb- Granular formulation (CO2-generating) coated with CGA-293343 and feeding stimulants

GRAPH 23

Larval Bioassays in Soil Tubes

Granules with Increasing Amounts of CGA-293343

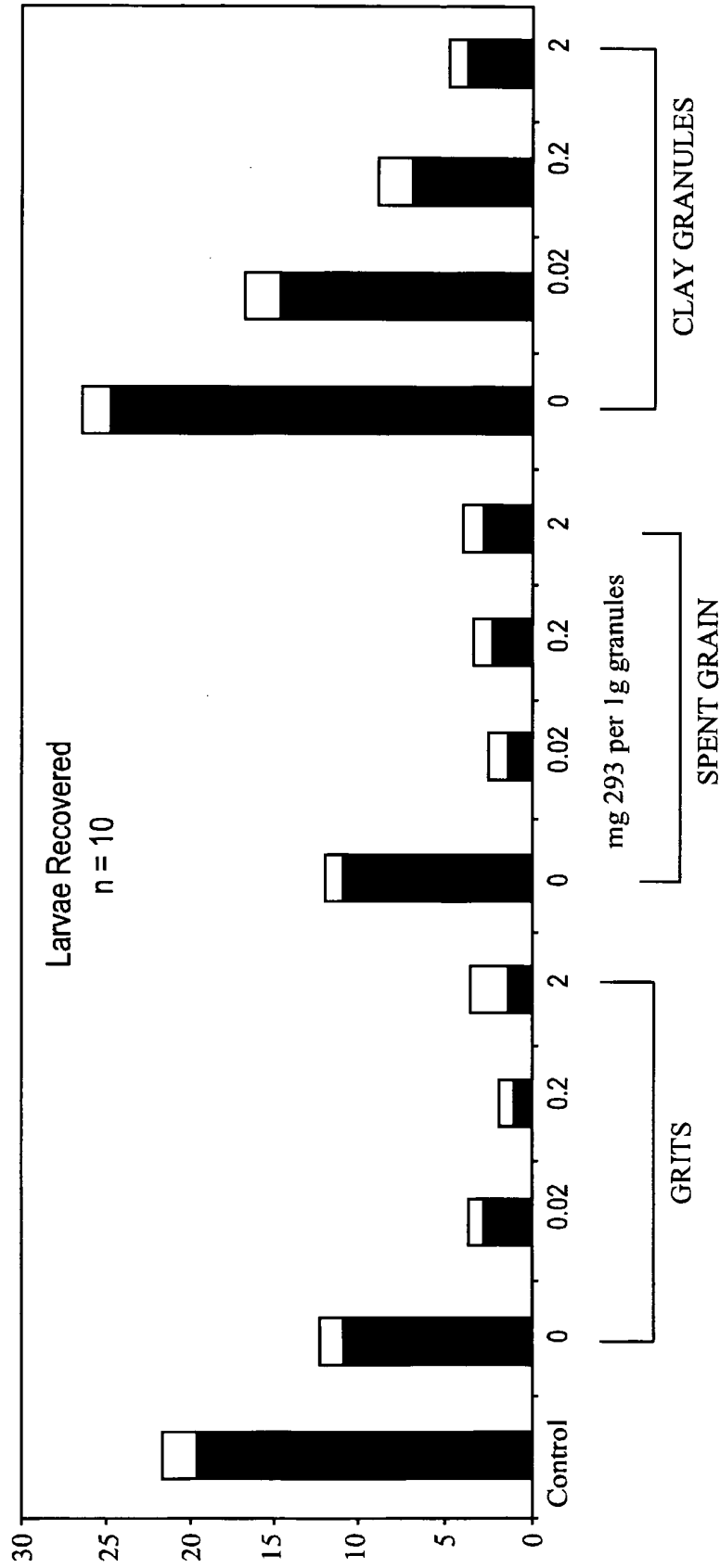

All granules contain feeding stimulant

Particularly preferred pesticidal compositions that can be used in conjunction with CO₂ and feeding stimulants referenced above comprise:

- at least one pesticidally active compound,
- 5 • at least one signal substance,
- at least one liquid UV absorber which is only sparingly miscible with water,
- 10 • at least one curable polymer which, after drying of the formulation, has a sponge-like structure or forms a porous film
- at least one surfactant and
- 15 • if appropriate additives

and which dry and harden after application. Compositions according to the invention can be prepared by

- 20 • a) mixing at least one pesticidally active compound, at least one signal substance, at least one liquid UV absorber which is only sparingly miscible with water and, if appropriate, additives,
- b) dispersing the resulting mixture in a solution of at least one surfactant and water and
- 25 • c) treating the resulting emulsion with an aqueous solution or dispersion of at least one curable polymer which, after drying of the formulation, has sponge-like structure or forms a porous film, and if appropriate, with additives.
- 30

The compositions according to the invention comprise one or more pesticidally active compounds. These are to be understood as meaning all customary substances which are suitable for combating harmful insects and undesirable representatives of the order Acarina. The following are preferably suitable, 35 carbamates, organophosphorous compounds, nitrophenols and their derivatives, nitromethylenes, nicotinoids, formamidines, ureas, phenylbenzoylureas, pyrethroids, chlorinated hydrocarbons and *Bazillus thuringensis* preparations. The following substances may be mentioned as examples:

- 40 • abamectin, AC 303 630, acephate, acrinathrin, alanycarb, aldicarb, alphamethrin, amitraz, avermectin, AZ 60541, azadirachtin, azinphos A, azinphos M, azocyclotin,

- Bacillus thuringiensis, bendiocarb, benfuracarb, bensultap, betacyfluthrin, bifenthrin, BPMC, brofenprox, bromophos A, bufencarb, buprofezin, butocarboxin, butylpyridaben,
- 5 • cadusafos, carbaryl, carbofuran, carbophenothion, carbosulfan, cartap, CGA 157 419, CGA 184699, chloethocarb, chlorethoxyfos, chlorfenvinphos, chlorfluazuron, chlormephos, chlorpyrifos, chlorpyrifos M, cis-Resmethrin, clocythrin, clofentezine, cyanophos, cycloprothrin, cyfluthrin, cyhalothrin, cyhexatin, cypermethrin, cyromazine,
- 10 • deltamethrin, demeton M, demeton S, demeton-S-methyl, diafenthiuron, diazinon, dichlofenthion, dichlorvos, dicliphos, dicrotophos, diethion, diflubenzuron, dimethoate,
- 15 • dimethylvinphos, dioxathion, disulfoton,
- edifenphos, emamectin, esfenvalerate, ethiofencarb, ethion, ethofenprox, ethoprophos, etrimphos,
- 20 • fenamiphos, fenazaquin, fenbutatin oxide, fenitrothion, fenobucarb, fenothiocarb, fenoxycarb, fenpropathrin, fenpyrad, fenpyroximate, fenthion, fenvalerate, fipronil, fluazinam, flucycloxuron, flucythrinate, flufenoxuron, flufenprox, fluvalinate, fonophos, formothion, fosthiazate, fubfenprox, furathiocarb,
- 25 • HCH, heptenophos, hexaflumuron, hexythiazox,
- imadacloprid, iprobenfos, isazophos, isofenphos, isoprocarb, isoxathion, ivermectin, lambda-cyhalothrin, lufenuron,
- 30 • malathion, mecarbam, mervinphos, mesulfenphos, metaldehyde, methacrifos, methamidophos, methidathion, methiocarb, methomyl, metolcarb, milbemectin, monocrotophos, moxidectin,
- 35 • naled, NC 184, NI 25, nitenpyram,
- omethoat, oxamyl, oxydemethon M, oxydeprofos,
- 40 • parathion A, parathion M, permethrin, phenthoate, phorate, phosalone, phosmet, phosphamidon, phoxim, pirimicarb, pirimiphos M, pirimiphos A, profenofos, promecarb, propaphos, propoxur, prothiofos, prothoate, pymetrozin, pyrachlophos, pyridaphenthion, pyresmethrin, pyrethrum, pyridaben, pyrimidifen, pyriproxifen,
- 45 • quinalphos,
- RH 5992,

- salithion, sebufos, silafluofen, sulfotep, sulprofos, tebufenozyd, tebufenpyrad, tebupirimiphos, teflubenzuron, tefluthrin, temephos, terbam, terbufos, tetrachlorvinphos, thiafenox, thiodicarb, thiofanox, thiomethon, thionazin, thuringiensin, tralomethrin, triarathen, triazophos, triazuron, trichlorfon, triflumuron, trimethacarb, transfluthrin
- vamidothion, XMC, xylylcarb, zetamethrin

Signal materials which the compositions according to the invention comprise can be all customary substances which have an attractant action on the pests to be combated and which alter the behaviour of these pests. Signal substances which are preferably suitable are pheromones, kairomones and attractants. Examples of such materials which may be mentioned are the following substances.

- Z-5-decenyl acetate, dodecanyl acetate, Z-7-dodecenyl acetate, E-7-dodecenyl acetate, Z-8-dodecenyl acetate, E-8-dodecenyl acetate, Z-9-dodecenyl acetate, E-9-dodecenyl acetate, E-10-dodecenyl acetate, 11-dodecenyl acetate, Z-9, 11-dodecadienyl acetate, E-9, 11-dodecadienyl acetate, Z-11-tridecenyl acetate, E-1-tridecenyl acetate, tetradecenyl acetate, E-7-tetradecenyl acetate, Z-8-tetradecenyl acetate, E-8-tetradecenyl acetate, Z-9-tetradecenyl acetate, E-9-tetradecenyl acetate, Z-10-tetradecenyl acetate, E-10-tetradecenyl acetate, Z-11-tetradecenyl acetate, E-11-tetradecenyl acetate, Z-12-pentadecenyl acetate, E-12-pentadecenyl acetate, hexadecanyl acetate, Z-7-hexadecenyl acetate, Z-11-hexadecenyl acetate, E-11-hexadecenyl acetate, octadecanyl acetate, E,Z-7,9-dodecadienyl acetate, Z,E-7,9-dodecadienyl acetate, E,E-7,9-dodecadienyl acetate, Z,Z-7,9-dodecadienyl acetate, E,E-8,10-dodecadienyl acetate, E,Z-9,12-dodecadienyl acetate, E,Z-4,7-tridecadienyl acetate, 4-methoxycinnamaldehyde, β -ionone, estragole, eugenol, indole, 8-methyl-2-decyl propanoate, EE-9,11-tetradecadienyl acetate, Z,Z-9,12-tetradecadienyl acetate, Z,Z-7,11-hexadecadienyl acetate, E,Z-7,11-hexadecadienyl acetate, Z,E-7,11-hexadecadienyl acetate, E,E-7,11-hexadecadienyl acetate, Z,E-3,13-octadecadienyl acetate, E,Z-3,13-octadecadienyl acetate, E,E-3,13-octadecadienyl acetate, ethanol, hexanol, heptanol, octanol, decanol, Z-6-nonenol, E-6-nonenol, dodecanol, 11-dodecenol, Z-7-dodecenol, E-7-dodecenol, Z-8-dodecenol, E-8-dodecenol, E-9-dodecenol, Z-9-dodecenol, E-9,11-dodecadienol, Z-9,11-dodecadienol, Z,E-5,7-dodecadienol, E,E-5,7-dodecadienol, E,E-8,10-dodecadienol, E,Z-8,10-dodecadienol, Z,Z-8,10-dodecadienol, Z,E-8,10-dodecadienol, E,Z-7,9-dodecadienol, Z,Z-7,9-dodecadienol, E-5-tetradecenol, Z-8-tetradecenol, Z-9-tetradecenol, E-9-tetradecenol, Z-10-tetradecenol, Z-11-tetradecenol, E-11-tetradecenol, Z-11-hexadecenol, Z,E-9,11-tetradecadienol, Z,E-9,12-tetradecadienol, Z,Z-9,12-tetradecadienol, Z,Z-10,12-tetradecadienol, Z,Z-7,11-hexadecadienol, Z,E-7,11-hexadecadienol, (E)-14-methyl-8-hexadecen-1-ol, (Z)-14-methyl-8-hexadecen-1-ol,

E,E-10,12-hexadecadienol, E,Z-10,12-hexadecadienol, dodecanal, Z-9-dodecenal, tetradecanal, Z-7-tetradecenol, Z-9-tetradecenol, Z-11-tetradecenol, E-11-tetradecenol, E-11,13-tetradecadienal, E,E-8-10-tetradecadienal, Z,E-9,11-tetradecadienal, Z,E-9,12-tetradecadienal,

5 hexadecanal, Z-8-hexadecenal, Z-9-hexadecenal, Z-10-hexadecenal, E-10-hexadecenal, Z-11-hexadecenal, E-11-hexadecenal, Z-12-hexadecenal, Z-13-hexadecenal, (Z)-14-methyl-8-hexadecenal, (E)-14-methyl-8-hexadecenal, Z,Z-7,11-hexadecadienal, Z,E-7,11-hexadecadienal, Z,E-9,11-hexadecadienal, E,E-10,12-hexadecadienal,

10 E,Z-10,12-hexadecadienal, Z,E-10,12-hexadecadienal, Z,Z-10,12-hexadecadienal, Z,Z-11,13-hexadecadienal, octadecanal, Z-11-octadecenol, E-13-octadecenol, Z-13-octadecenol, Z-5-decenyl-3-methyl-butanoate Disparlure: (+) cis-7,8-epoxy-2-methyloctadecane, Seudenol: 3-methyl-2-cyclohexen-1-ol, sulcatol: -methyl-5-hepten-2-ol, Ipsenol: 2-methyl-6-methylene-7-octen-4-ol, Ipsdienol: 2-methyl-6-methylene-2,7-octadien-4-ol, Grandlure I: cis-2-isopropenyl-1-methylcyclobutanethanol, Grandlure II: Z-3,3-dimethyl-1-cyclohexanethanol, Grandlure III: Z-3,3-dimethyl-1-cyclohexaneacetaldehyde, Grandlure IV: E-3,3-dimethyl-1-cyclohexaneacetaldehyde, cis-2-verbenaol: cis-4,6,6-trimethylbicyclo[3,1,1]hept-3-en-2-ol cucurbitacin, 2-methyl-3-buten-2-ol, 4-methyl-3-heptanol, cucurbitacin, 2-methyl-3-buten-2-ol, 4-methyl-3-heptanol, alpha-pinene: 2,6,6-trimethylbicyclo[3,1,1]hept-2-ene, alpha-caryophyllene: 4,11,11-trimethyl-8-methylenebicyclo[7,2,0]undecane, Z-9-tricosene, alpha-multistriatin 2(2-endo, 4-endo)-5-ethyl-2,4-dimethyl-6,8-dioxabicyclo[3,2,1]octane, methyleugenol: 1,2-dimethoxy-4-(2-propenyl)phenol, Lineatin: 3,3,7-trimethyl-2,9-dioxatricyclo[3,3,1,0]nonane, Chalcogran: 2-ethyl-1,6-dioxaspiro[4,4]nonane, Frontalin: 1,5-Dimethyl-6,8-dioxabicyclo[3,2,1]octane, endo-Brevicommin: endo-7-ethyl-5-methyl-

30 6,8-dioxabicyclo[3,2,1]octane, exo-brevicommin: exo-7-ethyl-5-methyl-6,8-dioxabicyclo[3,2,1]octane, (Z)-5-(1-decenyl)dihydro-2-(3H)-furanone, Farnesol 3,7-11-trimethyl-2,6,10-dodecatrien-1-ol, Nerolidol 3,7-,11-trimethyl-1,6,10-dodecatrien-3-ol, 3-methyl-6-(1-methylethenyl)-9-decen-1-ol acetate,

35

- (Z)-3-methyl-6-(1-methylethenyl)-3,9-decadein-1-ol acetate, (E)-3,9-methyl-6-(1-methylethenyl)-5,8-decadien-1-ol-acetate, 3-methylene-7-methyl-octen-1-ol propionate, (Z)-3,7-dimethyl-2,7-octadien-1-ol propionate, (Z)-3,9-dimethyl-6-(1-methylethenyl)-3,9-decadien-1-ol propionate.

40

The compositions according to the invention comprise at least one liquid UV absorber which is only sparingly miscible with water. This is to be understood as meaning substances which are capable of absorbing UV light, preferably UV

45 radiation from the sunlight in a wavelength range of from 270 to 400 nm.

Suitable polymers which the compositions according to the invention comprise are all customary water-soluble or water-dispersible polymers or copolymers which, after application of the compositions, dry as a film to form a sponge-like, porous matrix. Polymers which are preferably suitable are those which can be synthesized by means of anionic or non-ionic polymerization of suitable monomers, for example by emulsion polymerization or bead polymerization with the aid of free-radical initiators or other initiator systems. Other polymers which can preferably be employed are those based on natural rubber latices.

Examples of particularly preferred polymers which may be mentioned are the following substances: polyvinyl acetate (Mowilith®), polyvinyl alcohols with various degrees of hydrolyzation (Mowiol®, polyvinylpyrrolidones (Luviskol K®, Agrimer®, polyacrylates (Carbopol®), acrylate-, polyol- or polyester-based varnish-system binders which are soluble or dispersible in water (Desmophen®, Roskydal®, Bayhydrol®, furthermore copolymers of two or more monomers such as acrylic acid, methacrylic acid, itaconic acid, maleic acid, fumaric acid, maleic anhydride, vinylpyrrolidone, ethylenically unsaturated monomers such as ethylene, butadiene, isoprene, chloroprene, styrene, divinylbenzene, *alpha*-methylstyrene or *p*-methylstyrene, furthermore vinyl halides, such as vinyl acetate, vinyl propionate or vinyl stearate, and also vinyl methyl ketone, or esters of acrylic acid or methacrylic acid with monohydric alcohols or polyols, such as methyl acrylate, methyl methacrylate, ethyl acrylate, ethylene methacrylate, lauryl acrylate, lauryl methacrylate, decyl acrylate, *N,N*-dimethylamino ethyl methacrylate, 2-hydroxyethyl methacrylate, 2-hydroxypropyl methacrylate or glycidyl methacrylate, furthermore diethyl esters or monoesters of unsaturated dicarboxylic acids, or else (meth)acrylamido-*N*-methylol methyl ether, amides or nitriles, such as acrylamide, methacrylamide, *N*-methylol-(meth)acrylamide, acrylonitrile, methacrylonitrile, and also *N*-substituted maleinimides and ethers, such as vinyl butyl ether, vinyl isobutyl ether or vinyl phenyl ether.

When the formulations dry, the polymers form a matrix which is not or only sparingly soluble, or sparingly dispensible, in water. Polymers which have a low glass transition temperature are preferably employed, in particular those substances with a glass transition temperature of below 50°C.

The compositions according to the invention comprise one or more surfactants. Suitable surface-active substances are all those which are conventionally used in the production of plant treatment products. The following are preferably suitable: non-ionic and anionic emulsifiers, such as polyoxyethylene fatty acid esters, polyoxyethylene fatty alcohol ethers, alkylaryl polyglycol ethers, fatty amine ethoxylates, alkylsulphonates, alkyl sulphates, alkylarylsulphonates, aryl sulphates and silicone surfactants. Examples of such surface-active substances are listed in McCutcheon's "Emulsifiers and Detergents" 1982 North America Edit. MC Publishing Co., 175 Rock Road, Glen rock, N.J. 07 452, USA.

Suitable additives which may be present in the compositions according to the invention are all those which can conventionally be used as additives in plant treatment products. These include colourants, antioxidants, thickeners, filters, antifreeze agents and solvents.

Suitable colorants are soluble dyes or sparingly soluble colour pigments, such as, for example, titanium dioxide, pigment-grade colour black or zinc oxide.

Suitable antioxidants are all substances which can conventionally be employed for this purpose in plant treatment products. Sterically hindered phenols and alkyl-substituted hydroxyanisoles and hydroxytoluenes are preferred.

Thickeners which are suitable are all substances which can conventionally be employed for this purpose in plant treatment products. The following are preferably suitable: organic polymers, such as partially or fully neutralized polyacrylic acids (Carbopol®), polyethylene glycols (Polyox®), polyvinyl alcohols and non-ionically or ionically modified celluloses (Tylose®), xanthan-based thixotropic thickeners (Kelzan®), and also inorganic disperse thickeners, such as precipitated or pyrogenic silicas, kaolins, bentonites and aluminum/silicon mixed oxides.

Suitable antifreeze agents are all substances which can conventionally be employed for this purpose in plant treatment products. Urea, glycerol or propylene glycol are all preferably suitable.

Fillers are, again, all inert materials which can conventionally be employed for this purpose in plant treatment products. The following are preferably suitable: rockmeals, calcium carbonate, quartzmeal and aluminum/silicon mixed oxides or mixed hydroxides.

Solvents which are suitable are all inert organic solvents which can conventionally be employed for this purpose in plant treatment products. The following are preferred: glycols, such as propylene glycol and polyethylene glycols of different molecular weight ketones, such as methyl isobutyl ketone, methyl isopropyl ketone and cyclohexanone; amides, such as dimethylformamide or diethylformamide; N,N-dialkylated carboxamides (for example Hallcomid®); alkyl lactams, such as substituted pyrrolidones (for example N-methylpyrrolidone and Surfadone®) and caprolactams (for example Azone®); hydrocarbons, n-paraffins and isoparaffins having different boiling ranges as they are obtainable, for example, under the commercial names Exxol®, Norpar® and Isopar®; aromatic hydrocarbons, such as xylene and aromatic distillation fractions (for example Solvesso®); esters, such as propylene glycol monomethyl ether acetate, dibutyl adipate and di-n-butyl phthalate; ethers, such as propylene glycol methyl ether or propylene glycol butyl ether, alcohols, such as ethanol, – and i-propanol, – and i-butanol, – and i-amyl alcohol, benzyl alcohol, tetrahydrofurfuryl alcohol, 1-methoxy-2-propanol, and higher alcohols, and furthermore dimethyl sulphoxide, dioxane and tetrahydrofuran. The solvents can be employed in the form of individual components or of mixtures. Particularly preferred are those which are miscible with the UV stabilizer and which are not unduly volatile.

The concentration of individual components in the compositions according to the invention can be varied within a substantial range. After deducting the water present in the compositions according to the invention, the concentrations

- of pesticidally active compounds are generally between 0.1 and 10% by weight, preferably between 1 and 4% by weight.
- of signal substances are generally between 0.01 and 1% by weight, preferably 0.05 and 0.3% by weight.
- of UV absorbers are generally between 10 and 80% by weight, preferably between 40 and 70% by weight.
- of polymers of generally between 10 and 90% by weight, preferably between 25 and 75% by weight.
- of surface-active substances of generally between 0.1 and 4% by weight, preferably between 0.2 and 2% by weight, and

- of additives are generally between 0 and 50% by weight, preferably between 0 and 25% by weight.

In addition, the compositions according to the invention also comprise water.
5 The water content prior to drying varies within a substantial range. It is generally between 50 and 90% by weight.

When preparing the compositions according to the invention, a procedure is generally followed in which a premix is first prepared by dissolving or dispersing at least one pesticidally active compound and at least one signal substance in at least one
10 liquid UV absorber with stirring at temperatures between 20°C and 50°C., preferably at room temperature, and, if appropriate, additives are added. The premix is then dispersed into a stirred solution of at least one surfactant in water at temperatures between 20°C. and 50°C., preferably at room temperature. The dispersing process is carried out in such a way that an oil-in-water emulsion is formed in which the mean
15 particle size is generally between 0.5 and 50 µm. The resulting emulsion is subsequently treated with a solution or dispersion at least one polymer in water and, if appropriate, additives, at temperatures between 20°C. and 50°C., preferably at room temperature, with stirring. However, a different procedure may be followed when preparing the compositions according to the invention. In principle, it is possible to
20 mix the components in any desired sequence. All stirring and mixing apparatus customary for the preparation of the compositions according to the invention is suitable.

Upon preparation, the compositions according to the invention are obtained in a liquid or viscous state. After application, the viscous compositions dry and form a
25 non-flowable, non-tacky coating with good adhesive properties which has a sponge-like structure or forms a porous film. Once dry, the coating has a firm to rubber-like consistency.

The compositions according to the invention are highly suitable for combating harmful insects and undesirable representatives of the order Acarina, which are
30 encountered in agriculture, in forestry and in horticulture including viticulture. They can be used against the pests mentioned below.

From the order of the Isopoda, for example, *Oniscus asellus*, *Armadillidium vulgare* and *Porcellio scaber*.

From the order of the Diplopoda, for example, *Blaniulus guttulatus*.

From the order of the Chilopoda, for example, *Geophilus carpophagus* and *Scutigera spec.*

From the order of the Symphyla, for example, *Scutigera immaculata*.

From the order of the Thysanura, for example, *Lepisma saccharina*.

5 From the order of the Collembola, for example, *Onychiurus armatus*.

From the order of the Orthoptera, for example, *Blatta orientalis*.

Periplaneta americana, *Leucophaea maderae*, *Blattella germanica*, *Acheta domesticus*, *Gryllotalpa spp.*, *Locusta migratoria migratorioides*, *Melanoplus differentialis* and *Schistocerca gregaria*.

10 From the order of the Dermaptera, for example, *Forficula auricularia*.

From the order of the Isoptera, for example, *Reticulitermes spp.*

From the order of the Anoplura, for example, *Phylloxera vastatrix*, *Pemphigus spp.*, *Pediculus humanus corporis*, *Haematopinus spp.* And *Linognathus spp.*

15 From the order of the Mallophaga, for example, *Trichodectes spp.* and *Damalinea spp.*

From the order of the Thysanoptera, for example, *Hercinothrips femoralis* and *Thrips tabaci*.

20 From the order of the Heteroptera, for example, *Eurygaster spp.*, *Dysdercus intermedius*, *Piesma quadrata*, *Cimex lectularius*, *Rhodnius prolixus* and *Triatoma spp.*

25 From the order of the Homoptera, for example, *Aleurodes brassicae*, *Bemisia tabaci*, *Trialeurodes vaporariorum*, *Aphis gossypii*, *Brevicoryne brassicae*, *Cryptomyzus ribis*, *Aphis fabae*, *Doralis pomi*, *Eriosoma lanigerum*, *Hyalopterus arundinis*, *Macrosiphum avenae*, *Myzus spp.*, *Phorodon humuli*, *Rhopalosiphum padi*, *Empoasca spp.*, *Euscelis bilobatus*, *Nephotettix cincticeps*, *Lecanium corni*, *Saissetia oleae*, *Laodelphax striatellus*, *Nilaparvata lugens*, *Aonidiella aurantii*, *Aspidiotus hederae*, *Pseudococcus spp.* and *Psylla spp.*

30 From the order of the Lepidoptera, for example, *Pectinophora gossypiella*, *Bupalus piniarius*, *Cheimatobia brumata*, *Lithocolletis blancardella*, *Hyponomeuta padella*, *Pluella maculipennis*, *Malacosoma neustria*, *Euproctis chrysorrhoea*, *Lymantria spp.* *Bucculatrix thurberiella*, *Phyllocnistis citrella*, *Agrotis spp.*, *Euxoa spp.* *Feltia spp.*, *Earias insulana*, *Heliothis spp.*, *Spodoptera exigua*, *Mamestra brassicae*, *Panolis flammea*, *Prodenia litura*, *Spodoptera spp.*, *Trichoplusia ni*,

Carpocapsa pomonella, Pieris spp., Chilo spp., Pyrausta nubilalis, Ephestia kuehniella, Galleria mellonella, Tineola bisselliella, tineola pellionella, Hofmannophila pseudospretella, Cacoecia podana, Capua reticulana, Choristoneura fumiferana, Clysia ambiguella, Homona magnanima and Tortrix viridana.

5 From the order of the Coleoptera, for example, Anobium punctatum, Rhizopertha dominica, Acanthoscelides obtectus, Bruchidius obtectus, Hylotrupes bajulus, Agelastica alni, Leptinotarsa decemlineata, Phaedon cochleariae, Diabrotica spp., Psylliodes chrysocephala, Epilachna varivestis, Atomaria spp., Oryzaephilus surinamensis, Anthonomus spp., Sitophilus spp., Otiorrhynchus sulcatus, 10 Cosmopolites sordidus, Ceuthorrhynchus assimilis, Hypera postica, Dermestes spp., Trogoderma spp., Anthrenus spp., Attagenus spp., Lyctus spp., Meligethes aeneus, Ptinus spp., Niptus holoeucus, Gibbium psylloides, Tribolium spp., Tenebrio molitor, Agriotes spp., Conoderus spp., Melolontha melolontha, Amphimallon solstitialis and Costelytra zealandica.

15 From the order of the Hymenoptera, for example, Diprion spp., Holocampa spp., Lasium spp., Monomorium pharaonis and Vespa spp.

From the order of the Diptera, for example, Aedes spp., Anopheles spp., Culex spp., Drosophila melanogaster, Musca spp., Fannia spp., Calliphora erythrocephala, Lucilia spp., Chrysomyia spp., Cuterebra spp., Gastrophilus spp., 20 Hyppobosca spp., Stomoxys spp., Oestrus spp., Hypoderma spp., Tabanus, spp., Tannia spp., Bibio hortulanus, Oscinella frit, Phorbia spp., Pegomyia hyoscyami, Ceratitis capitata, Dacus oleae and Tipula paludosa.

From the order of the Siphonaptera, for example, Xenopsylla cheopis and Ceratophyllus spp.

25 From the order of the Arachnida, for example, Scorpio maurus and Latrodectus mactans.

From the order of the Acarina, for example, Acarus siro, Argas spp., Ornithodoros spp., Dermanyssus gallinae, Eriophyes ribis, Phyllocoptura oleivora, Boophilus spp., Rhipicephalus spp., Ambylomma spp., Hyalomma spp., Ixodes spp., 30 Psoroptes spp., Chorioptes spp., Sarcoptes spp., Tarsonerous spp., Bryobia praetiosa, Panonychus spp. and Tetranychus spp.

The compositions according to the invention can be applied to the plants or areas under cultivation to be treated in the form of droplets, drop-like areas or thin

defined layers by using conventional devices as they are known to those skilled in the art. Particularly suitable for the treatment of fruit-bearing trees or of vines is a process in which a defined amount of the formulations according to the invention is applied to the stem of the plants with the aid of dosing dispensers, pipettes or syringes, it also being possible for the application devices to be provided with a brushing device or with a surface nozzle to distribute the compositions over a substantial area to cover it entirely. It is also possible to spread the formulations according to the invention onto a solid carrier where they are allowed to harden, to cut up the resulting solid coatings and to attach the individual pieces at the sites where they are desired in each case.

The amounts in which the compositions according to the invention are applied can be varied within a substantial range. They are generally on the order of magnitude which is conventionally chosen for the application of "attract-and-kill formulations".

One new class of insecticides that is gaining significant recognition in the market place are the so-called "neonicotinoid" insecticides. Compounds of this class include, for example, the compounds imidacloprid, acetamiprid, and thiamethoxam that are described, for example, in U.S. patent nos. 4742060 and 5304566 and EP580553A2, respectively.

At least one neonicotinoid compound of formula (I)

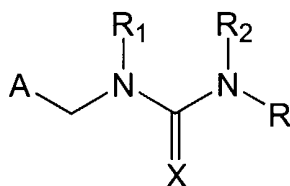

(I),

wherein

A is 2-chloropyrid-5-yl, 2-methylpyrid-5-yl, 1-oxido-3-pyridinio, 2-chloro-1-oxido-5-pyridinio, 2,3-dichloro-1-oxido-5-pyridinio, tetrahydrofuran-3-yl, 5-methyl-tetrahydrofuran-3-yl or 2-chlorothiazol-5-yl group,

R is hydrogen, C₁-C₆alkyl, phenyl-C₁-C₄alkyl, C₃-C₆cycloalkyl, C₂-C₆alkenyl or C₂-C₆alkynyl;

R₁ and R₂ are independently of each other C₁-C₄-alkyl, C₁-C₄-alkenyl, C₁-C₄-alkynyl, -C(=O)-CH₃ or benzyl; or together form a group -CH₂-CH₂-, -CH₂-CH₂-CH₂-, -CH₂-O-CH₂-, -CH₂-S-CH₂-, -CH₂-NH-CH₂- or -CH₂-N(CH₃)-CH₂-; and

X is N-NO₂ or N-CN or CH-NO₂; , or, where appropriate, a tautomer thereof, in each case in free form or in salt form.

The compounds (I) may be in the form of tautomers. Accordingly, hereinbefore and hereinafter, where appropriate the compound compounds (I) are to be understood to include corresponding tautomers, even if the latter are not specifically mentioned in each case.

Preferred compounds of the formula (I) are those wherein A is a pyrid-3-yl, 2-chloropyrid-5-yl, 2-chloro-1-oxido-5-pyridinio or 2-chlorothiazol-5-yl group; particularly a 2-chloropyrid-5-yl group or preferably a 2-chlorothiazol-5-yl group; wherein R is C₁-C₆alkyl, phenyl-C₁-C₄alkyl, C₃-C₄alkenyl or C₃-C₄alkynyl; more especially C₁-C₄alkyl, preferably methyl; R₁ and R₂ are independently of each other C₁-C₄-alkyl or benzyl, or together a group -CH₂-CH₂-, -CH₂-CH₂-CH₂-, -CH₂-O-CH₂-, -CH₂-S-CH₂-, -CH₂-NH-CH₂-, -CH₂-N(CH₃)-CH₂-, especially group -CH₂-CH₂- or -CH₂-O-CH₂-, particularly -CH₂-O-CH₂-; and X is N-NO₂ or N-CN, more especially N-NO₂.

Especially preferred is an at least quaternary pesticidal composition comprising an insecticidally effective amount of a compound selected from the group consisting of: a compound of the formula

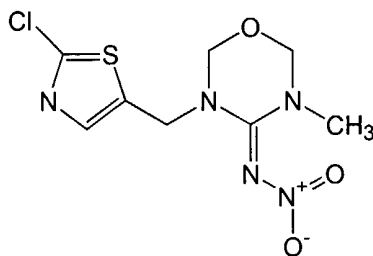

(Ia),

imidacloprid, (E)-1-(2-chlorothiazol-5-ylmethyl)-3-methyl-nitroguanidine (TI-435), nitenpyram, thiacloprid, and acetamiprid; particularly the compound of the formula (Ia) (thiamethoxam or CGA 293,343).

The compounds (I) are capable of forming acid addition salts. Those salts are formed, for example, with strong inorganic acids, such as mineral acids, for example

perchloric acid, sulfuric acid, nitric acid, nitrous acid, a phosphoric acid or a hydrohalic acid, with strong organic carboxylic acids, such as unsubstituted or substituted, for example halo-substituted, C₁-C₄alkanecarboxylic acids, for example acetic acid, saturated or unsaturated dicarboxylic acids, for example oxalic, malonic, succinic, maleic, fumaric or phthalic acid, hydroxycarboxylic acids, for example ascorbic, lactic, malic, tartaric or citric acid, or benzoic acid, or with organic sulfonic acids, such as unsubstituted or substituted, for example halo-substituted, C₁-C₄alkane- or aryl-sulfonic acids, for example methane- or p-toluene-sulfonic acid. Furthermore, compounds of formula (I) having at least one acidic group are capable of forming salts with bases. Suitable salts with bases are, for example, metal salts, such as alkali metal or alkaline earth metal salts, for example sodium, potassium or magnesium salts, or salts with ammonia or an organic amine, such as morpholine, piperidine, pyrrolidine, a mono-, di- or tri-lower alkylamine, for example ethyl-, diethyl-, triethyl- or dimethyl-propyl-amine, or a mono-, di- or tri-hydroxy-lower alkylamine, for example mono-, di- or tri-ethanolamine. In addition, corresponding internal salts may also be formed. Preference is given within the scope of the invention to agrochemically advantageous salts. In view of the close relationship between the compounds of formula (I) in free form and in the form of their salts, any reference hereinbefore or hereinafter to the free compounds of formula (I) or to their respective salts is to be understood as including also the corresponding salts or the free compounds of formula (I), where appropriate and expedient. The same applies in the case of tautomers of compounds of formula (I) and the salts thereof. The free form is generally preferred in each case.

Yet a further aspect of the present technology relates to the combination of an attractant feeding stimulant for corn root worm with particular insecticides. For example, in one embodiment, an attractant feeding stimulant for corn root worm with a neonicotinoid class of insecticides, and even more preferably, thiamethoxam. The inventors are the first to appreciate that while commonly used corn root worm insecticides, (such as organophosphates/carbonates) repel the neonate corn root worm larvae, neonicotinoid compounds do not repel such larvae. Thus, the present invention provides for the attraction of corn root worms used in conjunction with a technology that terminates or kills such root worms and root worm larvae, thus providing a fully functional root worm control method and compound whether

applied as a seed treatment or as a granule which is applied to the soil at planting. As one of ordinary skill in the art will appreciate, other insecticide compounds that do not repel boring insects, such as the corn root worm, will also find application and are within the scope of the invention.

5 Of the many possible formulations that can be utilized in conjunction with the present invention are those described in U.S. Patent No. 5,707,638, incorporated in its entirety herein by this reference. In particular, an insecticidal attract-and-kill formulation comprising the following is useful in combination with the CO₂ attractants mentioned herein:

- 10 • 0.1 to 10% by weight of an insecticidally active compound selected from cyfluthrin, β-cyfluthrin and transfluthrin,
- 15 • 0.01 to 1% by weight of a signal substance selected from E,E-8, 10-dodecanediol and Z-11-tetradecenyl acetate, 10 to 90% by weight of a polyvinyl acetate,
- 10 to 80% by weight of a UV absorber selected from a benzotriazole, and
- 20 • a 2-hydroxy-4-methoxy-benzophenone and 2-(2-ethyl-hexyl)-2-cyano 3,3-diphenyl-2 propenoate.

 The foregoing description of the present invention has been presented for purposes of illustration and description. Furthermore, the description is not intended to limit the invention to the form disclosed herein. Consequently, variations and modifications commensurate with the above teachings, and the skill or knowledge of the relevant art, are within the scope of the present invention. The embodiments described hereinabove are further intended to explain best modes known for practicing the invention and to enable others skilled in the art to utilize the invention in such, or other, embodiments and with various modifications required by the particular applications or uses of the present invention. It is intended that the appended claims be construed to include alternative embodiments to the extent permitted by the prior art.

25

30

What is claimed is:

1. A method to attract termites, comprising:
providing a CO₂ emitting source in an enclosure having openings sufficient to allow termites to pass therethrough, said CO₂ emitting source selected from the group comprising a biological, chemical or mechanical component, said CO₂ source releasing concentrations of CO₂ above that found in ambient soil;
providing an insecticide that does not repel a corn root worm larvae; and
positioning said enclosure with said CO₂ source contained therein at locations such that termites are attracted to said CO₂ source rather than to structures sought to be protected.
2. The method as set forth in Claim 1, wherein said CO₂ emitting source generates CO₂ in a concentration of from between about 2 to about 50 mm mol/mol.
3. The method as set forth in Claim 1, wherein said CO₂ emitting source comprises a biological source comprising charred cellulose material.
4. The method as set forth in Claim 1, wherein said CO₂ emitting source comprises CO₂ or CO₂ mimics combined with sources of insecticides, food, feeding stimulants and materials that stimulate insect movement.
5. The method as set forth in Claim 1, wherein said CO₂ emitting source comprising burned or charred natural or artificial materials.
6. The method as set forth in Claim 5, wherein said burned or charred materials are selected from the group consisting of wood, paper, cardboard, fabric, textiles, wool, silk, bone, hair, horn and claws.
7. The method as set forth in Claim 1, further comprising providing an agent toxic to termites within said enclosure.
8. A method for controlling root worm infestation, comprising:
applying an organic component selected from the group consisting of spent grain, distiller's grain, corn cob grits and microorganisms capable of producing effective amounts of CO₂ at about the time of planting and/or cultivation of a crop, and applying an effective amount of an insecticide in conjunction with said organic component, said component applied by a method selected from the group consisting of plowing said compound into a field onto which a crop is to be grown and applying said compound between the rows of crop plants, whereby said compound emits effective levels of CO₂ to attract corn root larvae.

9. The method as set forth in Claim 8, wherein the step of applying comprising plowing said organic component into the soil of a field such that said components are administered in strips between or adjacent to rows of corn.

5 10. The method as set forth in Claim 8, wherein said step of applying is conducted during the planting and cultivation periods of a corn crop.

11. The method as set forth in Claim 7, wherein said organic component comprises spent grain, distillers grain or corn cob grits in a dry state wherein said components are applied to a field prior to such components being web, and thus, still possessing the ability to evolve significant amounts of CO₂.

10 12. A method for attracting boring insects, comprising placing a source of CO₂ emitting agent, in combination with an insecticide that does not repel corn root worm larvae, an effective distance from the roots of plants such that larvae/insects are attracted to said agent without causing damage to said plant roots.

15 13. The method as set forth in Claim 12, wherein said boring insects are selected from the group consisting of termites, corn root worms, carpenter ants and carpenter bees.

14. A method as set forth in Claim 12, wherein said CO₂ emitting source further provides fertilization to said plants.

20 15. A formulation for attracting corn root worms, comprising an insecticide that does not repel corn root worms and an effective amount of a component selected from the group of spent grain, distillers grain, corn cob grits, germinated corn, clean cracked corn, malted barley, malted grain, corn gluten feed, fungal organisms, bacteria, algae, microorganisms, inorganic carbonates, calcium carbonate, bicarbonate, alkyl carbonate, urea-based components, and mixtures
25 thereof.

30 16. A termite trap device, comprising a jar having a cover operatively associated therewith, said cover having apertures therein such that the total area of apertures with respect to the jar's surface comprises no more than about 10% of the surface area of said cover, said jar containing an attractant material comprising a CO₂ emitting source.

17. The trap as set forth in Claim 16, wherein said jar also contains soil having a moisture content of at least about 10% by weight.

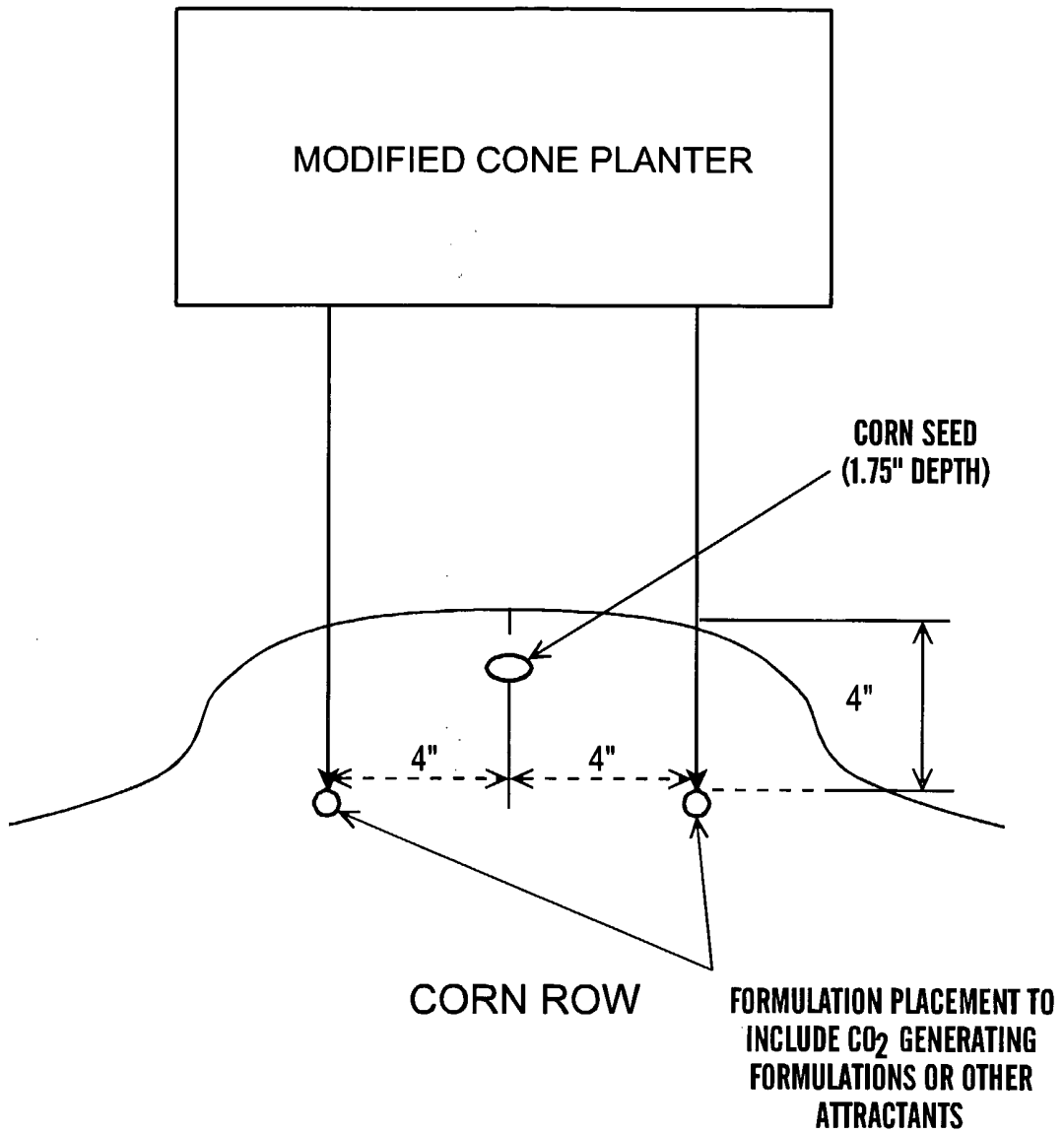

FIG. 1

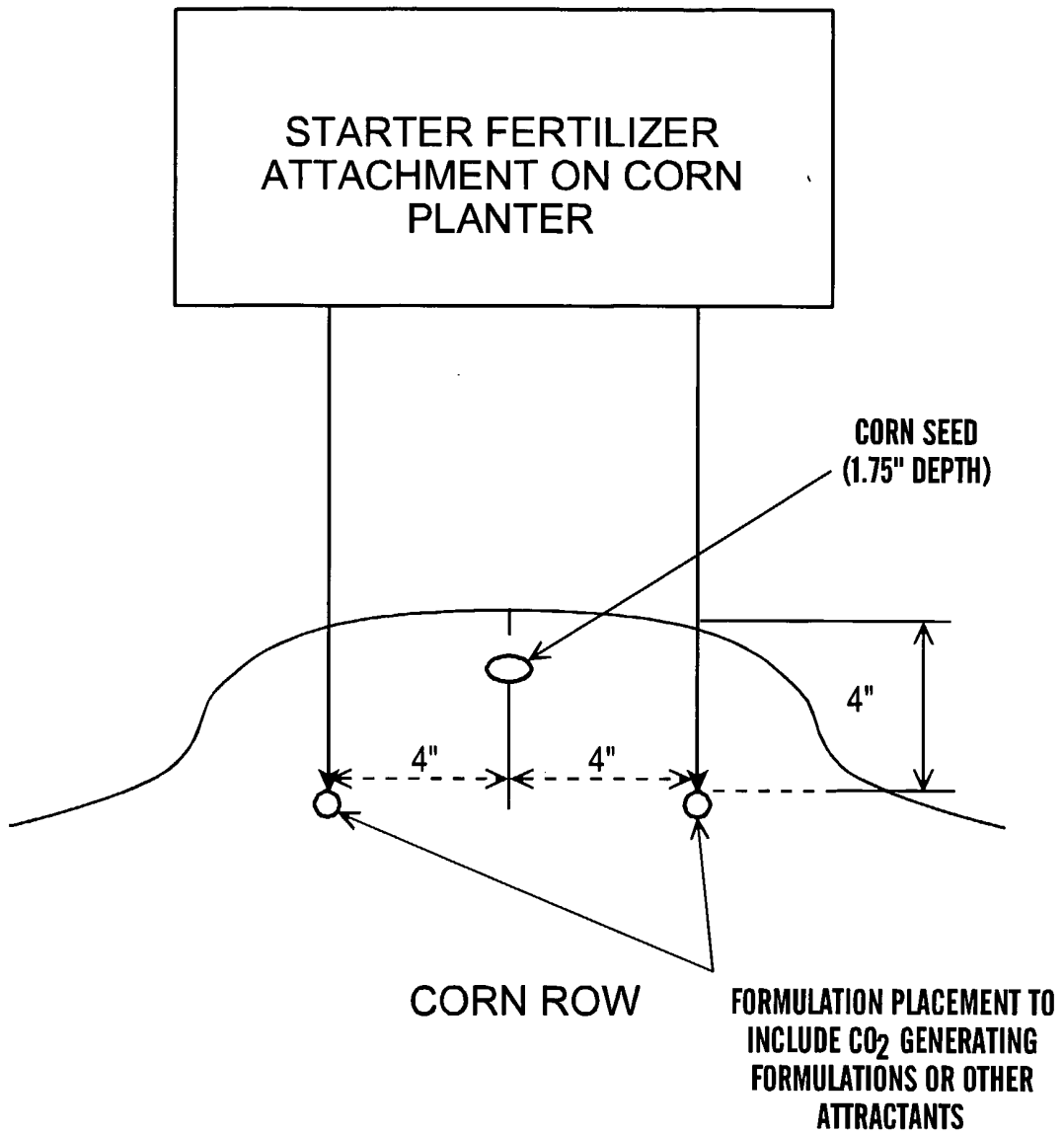

FIG. 2

3/3

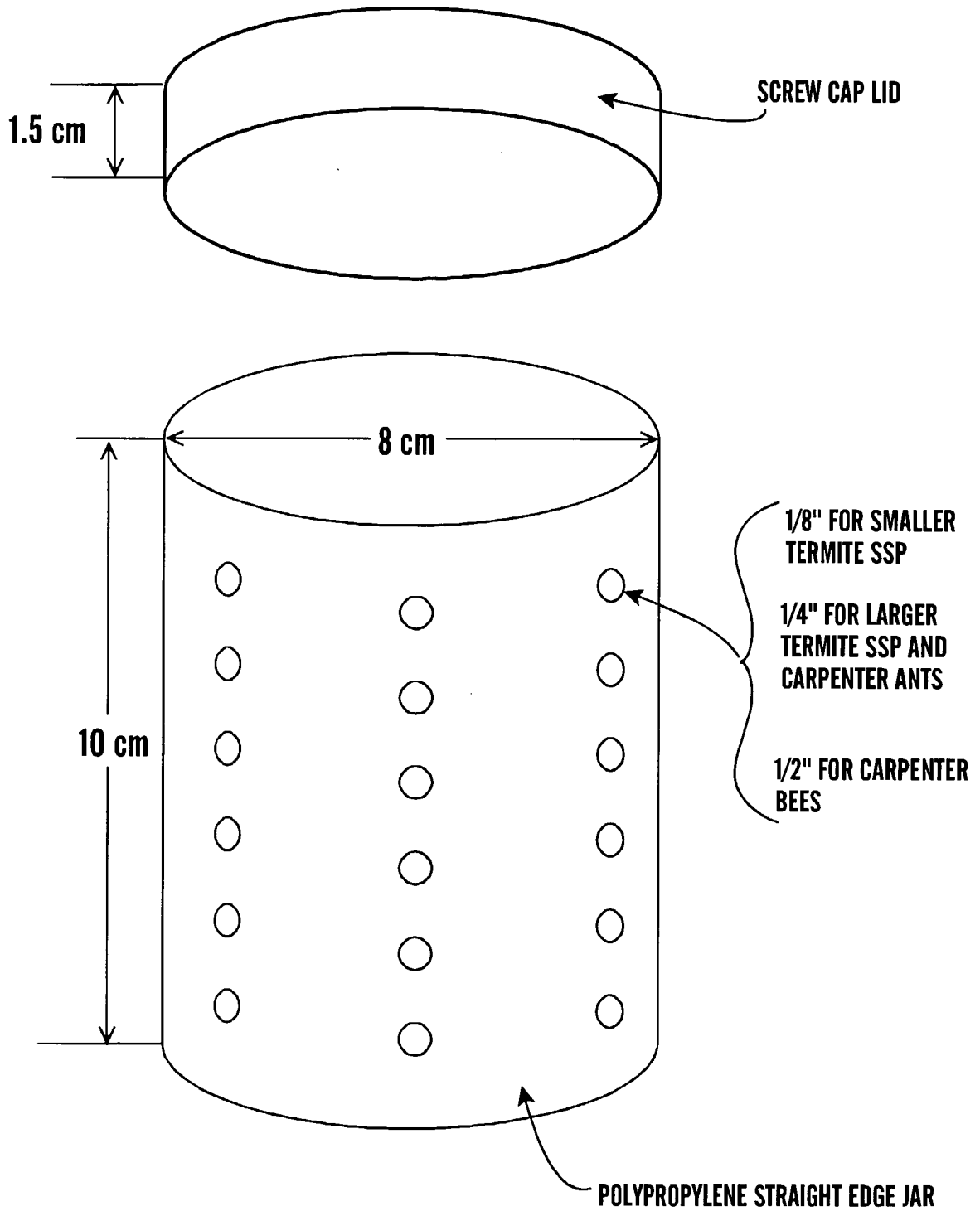

FIG. 3

INTERNATIONAL SEARCH REPORT

International application No.
PCT/US00/13477

A. CLASSIFICATION OF SUBJECT MATTER

IPC(7) :A01M 1/02, 1/10, 1/20; A01G 29/00; A01C 23/02; A01N 25/00

US CL :43/107, 121, 124, 131, 132.1; 47/1.01F; 111/118; 424/84, 405

According to International Patent Classification (IPC) or to both national classification and IPC

B. FIELDS SEARCHED

Minimum documentation searched (classification system followed by classification symbols)

U.S. : 43/107, 121, 124, 131, 132.1; 47/1.01F; 111/118; 424/84, 405

Documentation searched other than minimum documentation to the extent that such documents are included in the fields searched

Electronic data base consulted during the international search (name of data base and, where practicable, search terms used)

EAST

search terms: carbon dioxide, CO2, corn root worm, termite

C. DOCUMENTS CONSIDERED TO BE RELEVANT

| Category* | Citation of document, with indication, where appropriate, of the relevant passages | Relevant to claim No. |
|-----------|--|-----------------------|
| Y | US 5,189,830 A (MONTEMURRO) 02, March 1993, see entire document. | 1-7 |
| X | US 5,112,843 A (BJOSTAD, III et al) 12 May 1992, see entire document. | 12-15 |
| Y | | 1-11 |
| Y | US 5,329,726 A (THORNE et al) 19 July 1994, see entire document. | 3, 5-7 |
| Y | US 5,607,684 A (LEW et al) 04 March 1997, see entire document. | 8-11 |
| Y | US 1,599,408 A (CARDINET) 14 September 1926, see entire document. | 16 |
| Y | US 4,506,473 A (WATERS, JR) 26 March 1985, see entire document. | 16 |



Further documents are listed in the continuation of Box C.



See patent family annex.

| | | | |
|-----|---|-----|--|
| *A* | document defining the general state of the art which is not considered to be of particular relevance | *T* | later document published after the international filing date or priority date and not in conflict with the application but cited to understand the principle or theory underlying the invention |
| *E* | earlier document published on or after the international filing date | *X* | document of particular relevance; the claimed invention cannot be considered novel or cannot be considered to involve an inventive step when the document is taken alone |
| *L* | document which may throw doubts on priority claim(s) or which is cited to establish the publication date of another citation or other special reason (as specified) | *Y* | document of particular relevance; the claimed invention cannot be considered to involve an inventive step when the document is combined with one or more other such documents, such combination being obvious to a person skilled in the art |
| *O* | document referring to an oral disclosure, use, exhibition or other means | *&* | document member of the same patent family |
| *P* | document published prior to the international filing date but later than the priority date claimed | | |

Date of the actual completion of the international search

08 AUGUST 2000

Date of mailing of the international search report

17 OCT 2000

Name and mailing address of the ISA/US
Commissioner of Patents and Trademarks
Box PCT
Washington, D.C. 20231

Facsimile No. (703) 305-3230

Authorized officer

DARREN ARK

Telephone No. (703) 305-3733

INTERNATIONAL SEARCH REPORT

International application No.
PCT/US00/13477

Box I Observations where certain claims were found unsearchable (Continuation of item 1 of first sheet)

This international report has not been established in respect of certain claims under Article 17(2)(a) for the following reasons:

- 1. Claims Nos.:
because they relate to subject matter not required to be searched by this Authority, namely:

- 2. Claims Nos.:
because they relate to parts of the international application that do not comply with the prescribed requirements to such an extent that no meaningful international search can be carried out, specifically:

- 3. Claims Nos.:
because they are dependent claims and are not drafted in accordance with the second and third sentences of Rule 6.4(a).

Box II Observations where unity of invention is lacking (Continuation of item 2 of first sheet)

This International Searching Authority found multiple inventions in this international application, as follows:

Please See Extra Sheet.

- 1. As all required additional search fees were timely paid by the applicant, this international search report covers all searchable claims.
- 2. As all searchable claims could be searched without effort justifying an additional fee, this Authority did not invite payment of any additional fee.
- 3. As only some of the required additional search fees were timely paid by the applicant, this international search report covers only those claims for which fees were paid, specifically claims Nos.:

- 4. No required additional search fees were timely paid by the applicant. Consequently, this international search report is restricted to the invention first mentioned in the claims; it is covered by claims Nos.:

Remark on Protest The additional search fees were accompanied by the applicant's protest.
 No protest accompanied the payment of additional search fees.

INTERNATIONAL SEARCH REPORT

International application No.
PCT/US00/13477

BOX II. OBSERVATIONS WHERE UNITY OF INVENTION WAS LACKING

This ISA found multiple inventions as follows:

This application contains the following inventions or groups of inventions which are not so linked as to form a single inventive concept under PCT Rule 13.1. In order for all inventions to be searched, the appropriate additional search fees must be paid.

Group I, claim(s) 1-7 & 11, drawn to a method to attract termites.

Group II, claim(s) 8-10, drawn to a method for controlling root worm infestation.

Group III, claim(s) 12-14, drawn to a method for attracting boring insects.

Group IV, claim(s) 15, drawn to a formulation for attracting corn root worms.

Group V, claim(s) 16 & 17, drawn to a termite trap device.

The inventions listed as Groups I-V do not relate to a single inventive concept under PCT Rule 13.1 because, under PCT Rule 13.2, they lack the same or corresponding special technical features for the following reasons:

Group I is a method to attract termites comprising providing a CO₂ emitting source in an enclosure having openings not required in Groups II-V;

Group II is a method for controlling root worm infestation comprising applying an organic component selected from the group as claimed not required in Groups I & III-V;

Group III is a method for attracting boring insects comprising placing a source of CO₂ emitting agent an effective distance from the roots of plants not required in Groups I, II, IV, & V;

Group IV is a formulation for attracting corn root worms comprising an effective amount of a component selected from the group as claimed not required in Groups I-III & V;

Group V is a termite trap device comprising a jar having a cover not required in Groups I-IV.