

W. S. IRELAND.
TYPE WRITING MACHINE.
APPLICATION FILED APR. 5, 1910.

980,280.

Patented Jan. 3, 1911.

3 SHEETS—SHEET 1.

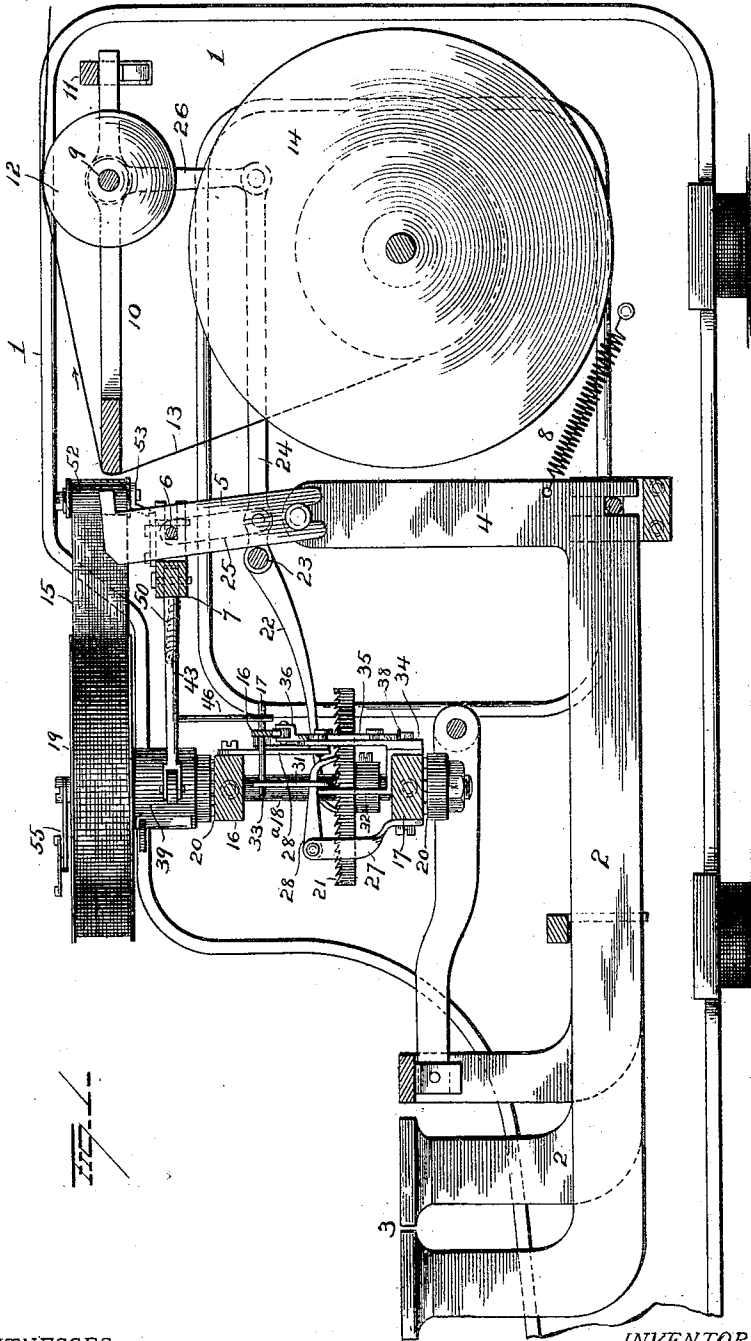

WITNESSES
B. Nottingham
G. J. Downing

INVENTOR
W. S. Ireland
Cy. A. Seymour
Attorney

W. S. IRELAND.
 TYPE WRITING MACHINE.
 APPLICATION FILED APR. 5, 1910.

980,280.

Patented Jan. 3, 1911.

3 SHEETS-SHEET 2.

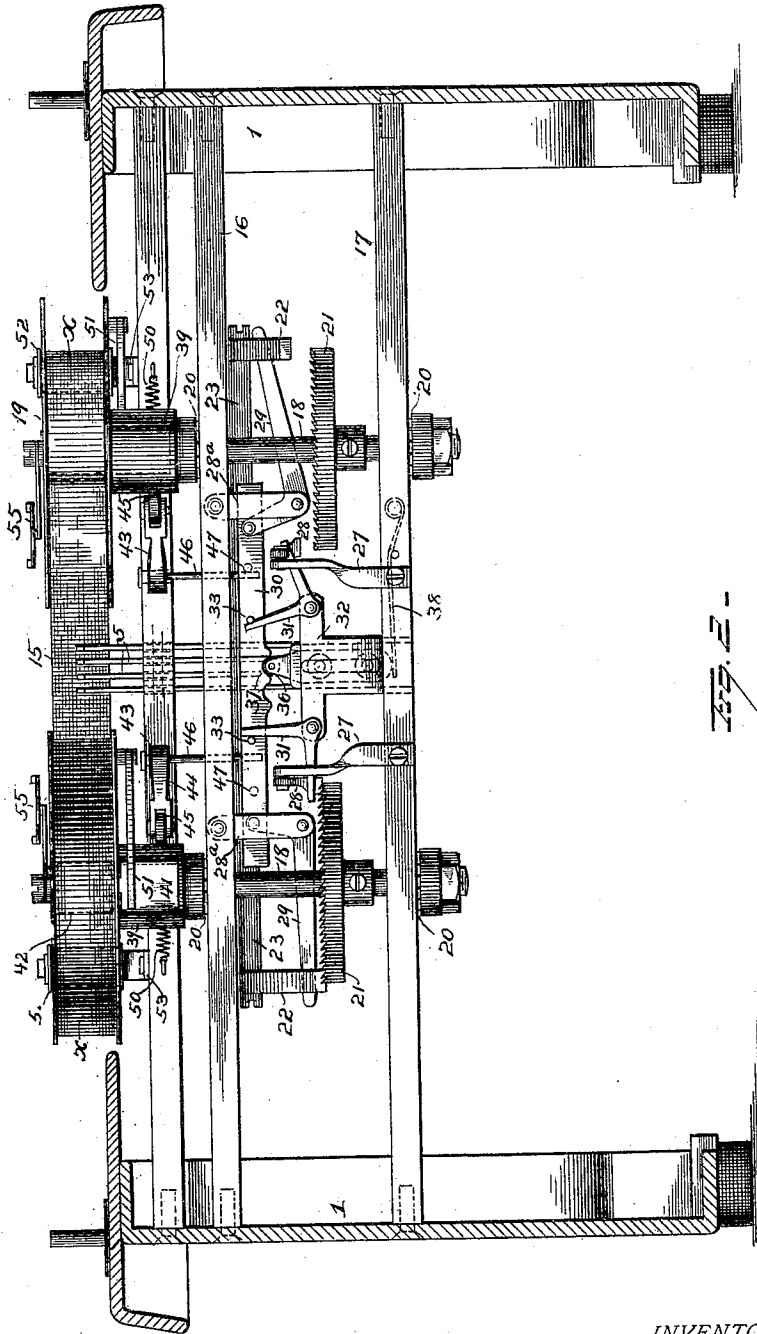

229.2 -

WITNESSES
E. Nottingham
G. J. Downing

INVENTOR
W. S. Ireland
By H. A. Seymour
 Attorney

W. S. IRELAND.
 TYPE WRITING MACHINE.
 APPLICATION FILED APR. 5, 1910.

980,280.

Patented Jan. 3, 1911.

3 SHEETS—SHEET 3.

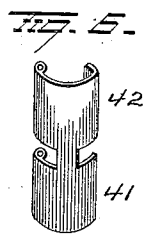
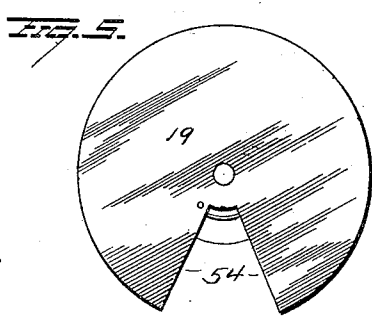
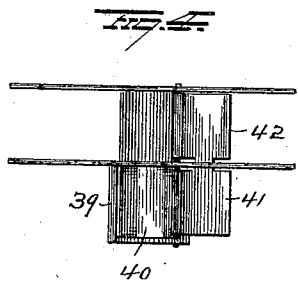
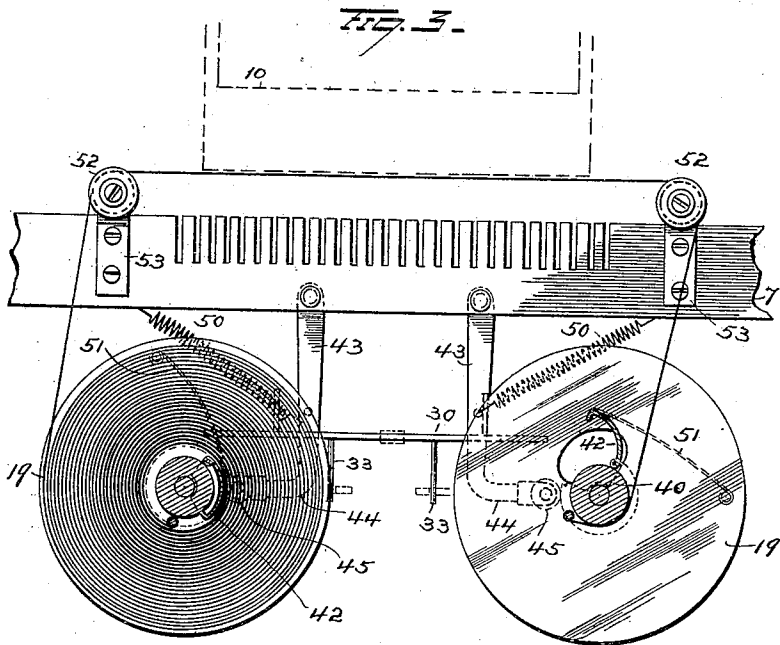

WITNESSES
E. Nottingham
G. J. Downing

INVENTOR
W. S. Ireland
Oy. H. A. Seymour
 Attorney

UNITED STATES PATENT OFFICE.

WARD S. IRELAND, OF DALLAS, TEXAS.

TYPE-WRITING MACHINE.

980,280.

Specification of Letters Patent.

Patented Jan. 3, 1911.

Application filed April 5, 1910. Serial No. 553,502.

To all whom it may concern:

Be it known that I, WARD S. IRELAND, of Dallas, in the county of Dallas and State of Texas, have invented certain new and useful Improvements in Type-Writing Machines; and I do hereby declare the following to be a full, clear, and exact description of the invention, such as will enable others skilled in the art to which it appertains to make and use the same.

This invention relates to improvements in typewriting machines and more particularly to ink-ribbon mechanism therefor,—the same being shown in the drawings as applied to a stenographic typewriting machine and controlled by the movement of the type-levers.

The object of my present invention is to provide simple and efficient means for feeding an inking-ribbon over a platen in front of the type on a row of vertically disposed type-levers and for automatically reversing the direction of feed of said ribbon.

With this object in view the invention consists in certain novel features of construction and combinations of parts as hereinafter set forth and pointed out in the claims.

In the accompanying drawings, Figure 1 is a longitudinal sectional view of a typewriting machine having my improvements applied thereto. Fig. 2 is a front elevation of the ribbon mechanism, with the frame of the machine shown in transverse section. Fig. 3 is a horizontal section on the line $x-x$ of Fig. 2. Figs. 4 and 5 are detail views of a ribbon reel, and Fig. 6 is a detail view of one of the trip-plates.

1 represents the main frame of the machine, in which key-levers 2 are mounted at one end and provided at their other ends with suitable keys or buttons 3. Arms 4 project upwardly from the pivoted ends of the key-levers and at their upper ends, said arms are pivotally connected with the lower ends of type-levers 5,—the latter being pivotally supported between their ends on a rod 6 in a notched bar 7 secured to the frame of the machine and extending transversely across the same. The key-levers 2 are maintained in and returned to their normal positions, as shown in Fig. 1 by means of springs 8, each having one end connected with a rigid part of the framework and the other end attached to an arm 4 of a key-lever a short

distance above the pivotal support of the latter,—said springs also serving to maintain the type-levers in and return them to their normal positions.

A rod 9 is mounted in the upper portion of the framework 1 near the rear end thereof and on this rod, a platen frame 10 is mounted,—the platen bar at one end of this frame being maintained in its normal position for cooperation with the type-levers by means of a fixed bar 11 with the under face of which the rear end of the platen frame engages.

A paper feed roller 12 is mounted on the rod 9 and with this roller paper feed mechanism (not shown) cooperates,—the paper strip or sheet 13 moving from a reel 14, passes in front of the platen bar and then rearwardly over the feed roller 12. An inking-ribbon 15 passes between the platen bar and the type on the row of type-levers and the means for controlling and reversing the feed of this inking-ribbon, and which constitute the subject-matter of my present invention will now be explained.

Two superimposed bars 16 and 17 are secured at their ends to the sides of the main frame 1 and extend transversely across the front portion of the latter. Vertical shafts 18 pass through these bars and carry at their upper ends ribbon reels 19,—roller bearings 20 being provided for said shaft to insure their free rotation. Each shaft 18 has secured thereto a ratchet wheel 21 having its teeth disposed vertically,—*i. e.*, on its upper edge or face. Pawls 22 are provided for cooperation with these ratchet wheels and both pawls 22 are carried by a universal bar 23 disposed in front of the row of type-levers and supported at the front ends of rods or pitmen 24, the latter being supported near one end by means of links 25 hung on the rod 6 and at their other ends said rods or pitmen are supported by arms 26 hung on the rod 9.

From this construction, it will be seen that when a key-lever is operated and the lower member of a cooperating type-lever is moved toward the front of the machine, the universal bar will be moved to transmit motion, through the medium of one of the pawls 22 to one of the ratchet wheels 21 for turning one of the ribbon reels to feed the ribbon,—the other pawl 22 being,

at this time, held out of engagement with its ratchet wheel by means of devices presently described. Upwardly projecting arms 27 are secured at their lower ends to the lower fixed bar 17 and to the upper ends of these arms, dogs or pawls 28 are pivotally attached and adapted to cooperate with the ratchet wheels 21 for preventing retrograde rotation of the latter.

Arms 28 depend from the upper fixed bar 16 and terminate above the horizontal plane of the ratchet wheels 21. To the lower ends of these arms bell-cranks 29 are pivotally attached so that one arm of each bell-crank will be disposed under one of the pawls 22. The upwardly projecting arms of the bell-cranks 29 are pivotally attached to and support a longitudinally movable bar 30 so that when said bar is moved in one direction, one of the bell-cranks will be operated to raise one of the pawls 22 from the adjacent ratchet wheel 21 and the other bell-crank 29 will be operated to permit the pawl 22 which it controls, to descend and cooperate with the adjacent ratchet wheel 21. Thus it will be seen that only one of the ribbon reels will be positively actuated to cause the travel of the ribbon in one direction during the operation of the machine, but that the direction of movement of the ribbon will be reversed when the bar 30 is moved to shift the propelling means from one reel shaft to the other. When one of the pawls 22 is moved out of operative relation with its ratchet wheel 21, it is necessary to also move the retaining dog or pawl 28 out of engagement with this ratchet wheel. To accomplish this, I provide bell-cranks 31 pivotally supported by a bracket 32 secured to the fixed bar 17 centrally between the ends of the latter. One arm of each bell-crank 31 projects under one of the retaining dogs 28 and the other arm projects upwardly in the path of a pin 33 on the longitudinally movable bar 30. It is apparent that when the bar 30 is moved in one direction to raise one of the pawls 22, the engagement of one of the pins 33 with a bell-crank 31 will cause the retaining pawl which cooperates with the ratchet wheel 21 from which the pawl 22 has been raised, to be elevated out of cooperative relation with said ratchet wheel and that the movement of the other pin 33 on the bar 30 in a direction away from the other bell-crank 31 will permit the other retaining pawl 28 to move into cooperative relation with its ratchet wheel 21. A plate 34 extends upwardly from the central portion of the fixed bar 17 and on this plate a vertically movable slide 35 is mounted and provided at its upper end with a roller 36 to engage one or another of the notches 37 in the lower edge of the longitudinally movable bar 30 for retaining said

bar and the devices which it actuates in the position to which the same may be moved,—said slide being pressed upwardly to insure the proper cooperation of the roller 36 with the bar 30, by means of a spring 38 as clearly shown in Fig. 2.

For the purpose of shifting the bar 30 when the inking-ribbon shall have become exhausted from one reel and thus automatically effect the reversal of the ribbon feed, the means now to be described will be employed. The hub of each ribbon reel is provided with an extension 39 depending from the reel and rotatable therewith. The extension 39 of each hub is made with a recess 40 and to normally close this recess, a trip-plate 41 is provided. The trip-plate 41 is hinged at one side of the recess 40 and is provided with an extension 42 which enters the reel and is shaped to partially embrace the reel hub between the heads of said reel. When ribbon is wound upon the reel, it will engage the extension 42 and retain it closely against the reel hub so as to cause the trip-plate to normally close or cover the recess 40 in the hub extension 39. Arms 43 are pivotally attached at one end to the bar 7 and provided at their free ends with lateral extensions 44 in which latter, rollers 45 are mounted and adapted to run on the hub extensions 39, being pressed into engagement with the latter by means of springs 50. Each arm 43 is provided with a depending pin 46 terminating in the path of movement of a pin 47 on the longitudinally movable bar 30,—two of such pins 47 being provided for cooperation with the pins 46 of the respective arms 43. A spring 51 is secured at one end to each reel and connected at its other end with a trip-plate 41 in such manner as to move the latter in a direction to open the recess 40 in the adjacent hub extension 39 when the ribbon shall have become exhausted from the reel,—said recess being normally closed by said trip-plate by the engagement of the ribbon on the spool or reel, with the extension 42 as before explained, and as shown in the left hand reel of Fig. 3. When the ribbon has become exhausted from a reel and the trip-plate or gate 41 has been moved to open the recess 40 in the hub extension, as shown in the right hand reel of Fig. 3, the adjacent arm 43 will be moved by the action of its spring 50,—such movement being permitted by the entrance of the roller 45 into the recess 40 of the hub extension 39. Such movement of the arm 43 will be transmitted, through the medium of pins 46—47 to the longitudinally movable bar 30 for operating the same as above described to render the actuating means of one ratchet wheel active and the actuating means of the other ratchet wheel inactive,—thereby reversing the direction of feed of the inking ribbon. In order to guide the inking rib-

bon in a straight line past the platen and the straight row of type, guide rollers 52 are mounted in suitable brackets 53 secured to the bar 7 beyond respective ends of the platen.

To facilitate the attachment of the inking ribbon to the reel or to the tape usually secured to such reels, one head or disk of each reel may be provided with an opening 54, as shown in Fig. 5. For enabling the operator to turn the reels manually, a crank or handle 55 is attached to the upper end of each reel shaft 18.

Having fully described my invention what I claim as new and desire to secure by Letters Patent, is,—

1. In a ribbon mechanism for typewriting machines, the combination with pivoted type-bars, and a universal bar supported in the path of movement of the type-bars, of parallel shafts, a ribbon reel and a ratchet wheel carried by each shaft, pawls for said ratchet wheels carried and operable by said universal bar, a longitudinally movable bar, and means cooperating with said last mentioned bar to raise the pawl from one ratchet wheel and permit the pawl of the other ratchet wheel to engage the latter.

2. In a ribbon mechanism for typewriting machines, the combination with pivoted type-bars, and a universal bar supported in the path of movement of the type-bars, of two parallel shafts, a reel carried by each shaft, a ratchet wheel carried by each shaft, actuating pawls for said ratchet wheels carried by said universal bar, a retaining pawl for each ratchet wheel, and means for moving the pawls of one ratchet wheel into operative relation therewith and for simultaneously moving the pawls of the other ratchet wheel out of operative relation with the same.

3. In a ribbon mechanism for typewriting machines, the combination with pivoted type-bars, and a universal bar supported in the path of movement of the type-bars, of two parallel shafts, a reel carried by each shaft, a ratchet wheel carried by each shaft, actuating pawls carried and operable by said universal bar for actuating said ratchet wheels, retaining pawls for said ratchet wheels, a longitudinally movable bar, means operable by said last mentioned bar for moving an actuating pawl into operative relation to one ratchet wheel and for moving the other actuating pawl out of operative relation to the other ratchet wheel, and separate means operable by the longitudinally movable bar for shifting the retaining pawls.

4. In a ribbon mechanism for typewriting machines, the combination with pivoted type-bars, and a universal bar supported in the path of movement of the type-bars, of parallel shafts, a reel carried by each shaft, a ratchet wheel carried by each shaft, actuating pawls for said ratchet wheels carried and

operable by the universal bar, retaining pawls for said ratchet wheels, a longitudinally movable bar, devices operable by said longitudinally movable bar for shifting the actuating pawls, other devices also operable by the longitudinally movable bar for simultaneously shifting the retaining pawls, and means controlled by the rotation of the reels to operate the longitudinally movable bar.

5. In a ribbon mechanism for typewriting machines, the combination with parallel shafts, a reel carried by each shaft, a recessed hub projecting from each reel, and a ratchet wheel carried by each shaft, of a spring actuated trip-plate or gate for closing the recess of each hub and projecting into each reel so as to be held by ribbon wound on the latter, actuating pawls for the ratchet wheels, means for operating said pawls, a longitudinally movable bar, means cooperating with said bar to move one of said pawls out of operative relation with the ratchet wheel and to move the other pawl into operative relation with its ratchet wheel, spring actuated arms having members to engage the projecting portions of the reel hubs and to enter the recesses of said hub when the trip-plates or gates are open, and means for transmitting the movement of said arms to the longitudinally movable bar.

6. In a ribbon mechanism for typewriting machines, the combination with parallel shafts, a reel carried by each shaft and a ratchet wheel carried by each shaft, of a bar, dogs carried by said bar for propelling said ratchet wheels, means for operating said bar, pivotally supported bell-cranks, each having an arm disposed under one of the actuating pawls, a longitudinally movable bar connecting the other arms of said bell-cranks, and means for moving said longitudinally movable bar to actuate the bell-cranks and move one of the pawls out of operative relation with its ratchet wheel and to move the other pawl into operative relation with its ratchet wheel.

7. In a ribbon mechanism for typewriting machines, the combination with a frame and superimposed bars fixed thereto, of parallel shafts mounted in said bars, a ribbon reel carried by each shaft, a ratchet wheel carried by each shaft, actuating pawls, means for operating said pawls, arms depending from the upper fixed bar, bell-cranks supported by said arms, each bell-crank having one member disposed under an actuating pawl, a longitudinally movable bar connecting the other arms of said bell-cranks, retaining pawls for said ratchet wheels, a bracket secured to the lower fixed bar, bell-cranks mounted on said bracket and each having an arm disposed under a retaining pawl, pins on the longitudinally movable bar for cooperation with the last mentioned bell-cranks, means for moving said longi-

tudinally movable bar and actuating the bell-
cranks to raise the pawls from one ratchet
wheel and permit the other pawls to engage
the other ratchet wheel, and means for re-
5 taining said longitudinally movable bar in
the position to which it may be moved.

In testimony whereof, I have signed this

specification in the presence of two subscri-
ing witnesses.

WARD S. IRELAND.

Witnesses:

S. G. NOTTINGHAM,
GEO. F. DOWNING.