

Feb. 23, 1926.

P. BASMAISON

1,574,725

BIT

Filed May 2, 1925

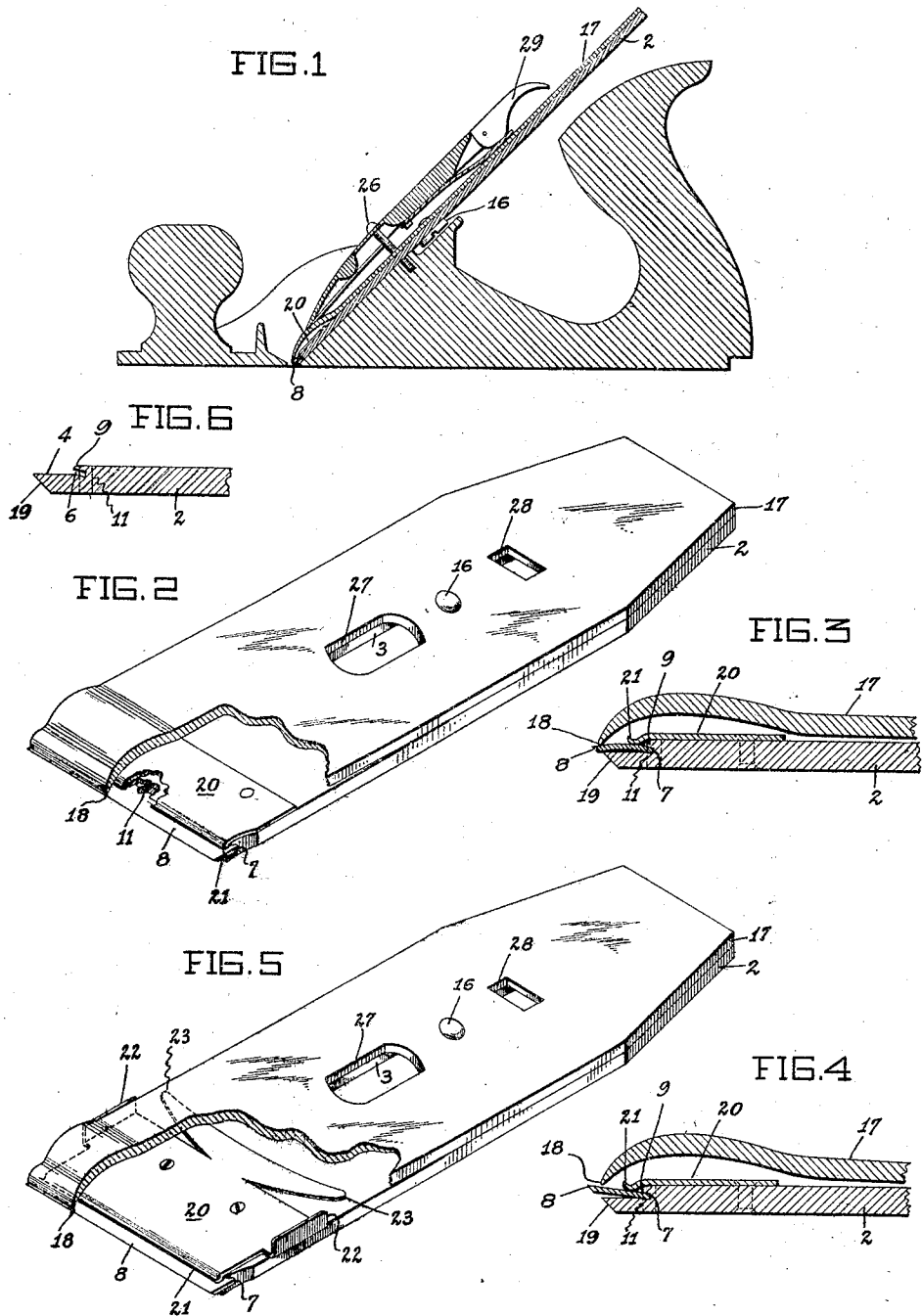

INVENTOR
PIERRE BASMAISON
BY
White Post + Evans
ATTORNEYS

UNITED STATES PATENT OFFICE.

PIERRE BASMAISON, OF SAN FRANCISCO, CALIFORNIA.

BIT.

Application filed May 2, 1925. Serial No. 27,450.

To all whom it may concern:

Be it known that I, PIERRE BASMAISON, a citizen of the United States, and a resident of the city and county of San Francisco, State of California, have invented a new and useful Bit, of which the following is a specification.

My invention relates to bits for wood-working tools and machines but particularly to plane bits.

An object of my invention is to provide a bit having improved means for holding the cutter.

Another object of the invention is the provision of means to prevent transverse movement of the cutter in the bit.

Another object of the invention is the inclusion of means to guide the clamp plate into position.

A further object of the invention is the provision of frictional resistance element to prevent accidental movement between the cutter blade and the clamp plate when they are in released position.

My invention possesses other objects and features of advantage, some of which with the foregoing, will be set forth in the following description of my invention. It is to be understood that I do not limit myself to the showing made by the said description as I may adopt variant embodiments of the invention within the scope of the claims.

Referring to the drawings:—

Figure 1 is a central vertical section through one of my bits assembled in a smooth plane.

Figure 2 is a perspective view of my bit, a portion of the clamp plate and spring plate being broken away to show the construction.

Figure 3 is a side elevation of my bit in clamped position.

Figure 4 is a side elevation of my bit in released position.

Figure 5 is a perspective view of a modified form of bit, a portion of the clamp plate being broken away to disclose the construction.

Figure 6 is a side elevation of the rabbeted and grooved end of the cutter blade.

The bit of my invention comprises a cutter blade 2 formed with the usual elongated slot 3 extending longitudinally there-

thru along a median line. The end of the cutter blade is provided with a rabbet 4 and a shallow groove 6 adapted to receive the non-cutting edge 7 of the cutter 8. Overhanging the groove 6 is a shoulder 9 against which the non-cutting edge 7 of the cutter bears. As shown in Figures 4 and 6, the groove is disposed in misalignment with, or at a slight angle to, the bottom of the rabbet so that the cutter seated in the groove extends outwardly and upwardly slightly above the surface of the rabbet. Disposed in the groove, preferably adjacent the center thereof, is a pin 11 which engages a complementary notch in the non-cutting edge of the cutter. By this means any longitudinal movement of the cutter is prevented, without affecting the ease of its removal or replacement.

Overlying the cutter blade and secured thereto by the usual set screw 16 is a clamp plate 17, the lower end of which is arched in the usual way and terminates in the clamping edge 18. Preferably the lower half of the clamp plate is bent slightly upwardly and away from the cutter blade so that when the clamp plate and the cutter blade are rigidly secured together by the set screw 16 in superposed relation, the clamping edge 18 lies somewhat above the end 19 of the cutter blade. At this time the cutter 8 lies at an angle to and is spaced above the rabbet, but in such a position that it is free of contact, or contacts lightly, with the clamping edge 18 of the clamp plate. When the assembled bit is placed in the plane the wedge forces the clamping edge 18 of the clamp plate against the cutter which in turn is placed under such tension that it is flexed into its seat against the rabbet. By this means the danger of the various elements of the bit becoming misaligned is obviated as the tension under which the parts are placed rigidly holds them together.

Means are provided for resiliently retaining the cutter in position in the cutter blade when not secured by the clamp plate, so that the bit may be removed from the plane and handled without the cutter falling from its seat. This is accomplished by a spring

plate 20 suitably secured to the upper face of the cutter blade and having a rolled or beaded edge 21 arranged to engage the cutter with sufficient force to retain it in place, but not sufficient to prevent its ready removal. Disposed on each side of the spring plate 20, and preferably integral therewith, are flanges 22, extending upwardly to form guides for the clamp plate, so that the clamp plate may be slipped into position on the cutter blade without difficulty in securing alinement of the two plates.

It will be found in the common type of bit, that the cutter blade and the clamp plate when loosely secured by the set screw 16 readily shift their relative positions, so that difficulty is encountered in maintaining the parts in position until the set screw can be tightened to hold the blade and plate rigidly together. In order to overcome this difficulty, I provide springs, tabs or wings 23 which are disposed between the clamp plate and cutter blade and which are preferably formed integrally with the spring plate 20. These tabs are curved or bent upwardly so that they bear against the clamp plate and provide frictional resistance to any movement between the cutter blade and the clamp plate.

The bit of my invention is positioned in the plane in the usual manner with the holding stud 26 passing thru the usual slots 3 and 27 of the cutter blade and the clamp plate respectively, and the adjusting stud engaging in the slot 28. The wedge is then dropped over the holding stud and the lever 29 pushed down so that the bit is locked in position.

I claim:—

1. In combination with the clamp of a plane, a bit comprising a cutter blade having a rabbeted end and a groove formed in the end wall of the rabbet, a cutter seated in said groove, said groove being misaligned with the rabbet to position the outer edge of the cutter above the rabbet, and means actuated by the clamp of the plane for flexing the cutter into a seat in the rabbet.

2. A bit comprising a cutter blade having a rabbeted end and a groove formed in the end wall of the rabbet, a cutter seated in said groove said groove being misaligned with the rabbet to position the outer edge of the cutter above the rabbet, and a clamp plate for pressing the cutter to a seat in said rabbet.

3. A plane bit comprising a cutter blade having a rabbeted end and a groove formed in the end wall of the rabbet, a cutter seated in said groove, said groove being misaligned with the rabbet to position the outer edge of the cutter above the rabbet, and a clamp plate for flexing the cutter under tension to a seat in said rabbet.

4. A bit comprising a cutter blade having

a rabbeted end and a groove formed in the end wall of the rabbet, a cutter seated in said groove and having a notch in the non-cutting edge, said groove being misaligned with the rabbet to position the outer edge of the cutter above the rabbet, a pin in said groove adapted to seat in said notch to prevent transverse movement of the cutter, and a clamp plate for flexing the cutter under tension to a seat in said rabbet.

5. A bit comprising a cutter blade having a rabbeted end and a groove formed in the end wall of the rabbet, a cutter seated in said groove, means interposed between said cutter and groove to prevent transverse movement of the cutter, said groove being misaligned with the rabbet to position the outer edge of the cutter above the rabbet, and a clamp plate for pressing the cutter to a seat in said rabbet.

6. A bit comprising a cutter blade having a rabbeted end and a groove formed in the end wall of the rabbet, a cutter seated in said groove, resilient means for retaining the cutter in said groove, said groove being misaligned with the rabbet to position the outer edge of the cutter above the rabbet, and a clamp plate for pressing the cutter to a seat in said rabbet.

7. A bit comprising a cutter blade having a rabbeted end and a groove formed in the end wall of the rabbet, a cutter seated in said groove, said groove being misaligned with the rabbet to position the outer edge of the cutter above the rabbet, a clamp plate for pressing the cutter to a seat in said rabbet, and flanges on each side of the cutter blade to guide the clamp plate into position.

8. A bit comprising a cutter blade having a rabbeted end and a groove formed in the end wall of the rabbet, a cutter seated in said groove, said groove being misaligned with the rabbet to position the outer edge of the cutter above the rabbet, a clamp plate for pressing the cutter to a seat in said rabbet, and means interposed between said cutter blade and clamp plate to resist relative movement between them.

9. A bit comprising a cutter blade having a rabbeted end and a groove formed in the end wall of the rabbet, a cutter seated in said groove, said groove being misaligned with the rabbet to position the outer edge of the cutter above the rabbet, a clamp plate for pressing the cutter to a seat in said rabbet, a resilient plate secured to the cutter blade for retaining the cutter in position when the bit is released, upturned flanges on each side of said resilient plate to guide said clamp plate into position, and wings on said resilient plate curved upwardly to bear against said clamp plate to resist movement between said cutter blade and clamp plate.

10. A bit comprising a cutter blade having a rabbet, a cutter arranged in said rab-

bet, a clamp plate for holding said cutter in the rabbet, a resilient plate secured to said cutter blade and adapted to resiliently retain the cutter in said rabbet, upturned
5 flanges on each side of said resilient plate to guide said clamp plate into position, and wings on said resilient plate curved upwardly to bear against said clamp plate to resist movement between said cutter blade and clamp plate. 10

In testimony whereof, I have hereunto set my hand.

PIERRE BASMAISON.