

(19) **DANMARK**



Patent- og
Varemærkestyrelsen

(10) **DK/EP 3893300 T3**

(12) **Oversættelse af
europæisk patentskrift**

-
- (51) Int.Cl.: **H 01 M 8/0202 (2016.01)** **H 01 M 8/0271 (2016.01)** **H 01 M 8/0286 (2016.01)**
H 01 M 8/12 (2016.01) **H 01 M 8/124 (2016.01)** **H 01 M 8/243 (2016.01)**
- (45) Oversættelsen bekendtgjort den: **2023-11-06**
- (80) Dato for Den Europæiske Patentmyndigheds bekendtgørelse om meddelelse af patentet: **2023-08-09**
- (86) Europæisk ansøgning nr.: **20168381.0**
- (86) Europæisk indleveringsdag: **2020-04-07**
- (87) Den europæiske ansøgnings publiceringsdag: **2021-10-13**
- (84) Designerede stater: **AL AT BE BG CH CY CZ DE DK EE ES FI FR GB GR HR HU IE IS IT LI LT LU LV MC MK MT NL NO PL PT RO RS SE SI SK SM TR**
- (73) Patenthaver: **Korea Institute of Energy Research, 152 Gajeong-ro , Yuseong-gu, Daejeon 34129, Sydkorea**
- (72) Opfinder: **KIM, Tae Woo, 205dong 205ho, 448, Expo-ro, Yuseong-gu, 34049 Daejeon, Sydkorea**
WOO, Sang Kuk, 202dong 702ho, 343, Jijok-ro, Yuseong-gu, 34071 Daejeon, Sydkorea
KIM, Sun Dong, 417dong, 1502ho, 13, Saerombuk-ro, 30126 Sejong-si, Sydkorea
SEO, Doo Won, 207dong 1601ho, 343, Jijok-ro, Yuseong-gu, 34071 Daejeon, Sydkorea
BANG, Hyung Joon, 131dong 1506ho, 57, Eoeun-ro, Yuseong-gu, 34140 Daejeon, Sydkorea
HAN, In Sub, 197-4, Sinam-gil, Yeonsan-myeon, 32911 Nonsan-si, Chungcheongnam-do, Sydkorea
KIM, Se Young, 117dong 303ho, 57, Eoeun-ro, Yuseong-gu, 34140 Daejeon, Sydkorea
KIM, Soo Hyun, 111dong 701ho, 13, Jeoljae-ro, 30100 Sejong-si, Sydkorea
SEONG, Young Hoon, 104dong 609ho, 29, Cheongsaseo-ro, Seo-gu, 35215 Daejeon, Sydkorea
BYUN, Segi, 706dong 1101ho, 38, Nari-ro, 30130 Sejong-si, Sydkorea
CHOI, Yoonseok, 402ho, 12-13, Hanbat-daero 570beon-gil, Seo-gu, 35221 Daejeon, Sydkorea
HWANG, Hyo Jung, 106dong 2001ho, 11, Dosan-ro, Seo-gu, 35401 Daejeon, Sydkorea
- (74) Fuldmægtig i Danmark: **Larsen & Birkeholm A/S Skandinavisk Patentbureau, Banegårdspladsen 1, 1570 København V, Danmark**
- (54) Benævnelse: **Flad, rørformet fastoxid-brændselscelle eller vandelektrolysecelle med integreret strømkollektor og fremstillingsfremgangsmåde dertil**
- (56) Fremdragne publikationer:
KR-B1- 101 826 821
US-A1- 2004 185 321
US-A1- 2013 025 292
US-A1- 2013 149 631
US-A1- 2016 372 778

DESCRIPTION

BACKGROUND

Field

[0001] The present disclosure relates to a solid oxide fuel cell or water electrolysis cell, and more particularly, to a solid oxide fuel cell or water electrolysis cell using an integrated current collector and a manufacturing method of the same.

Description of the Related Art

[0002] A solid oxide fuel cell (SOFC) is a fuel cell which uses solid oxide with oxygen or hydrogen ion conductivity as electrolytes and operates at the highest temperature (600 to 1000°C) among existing fuel cells. Further, all components are made of solid so that the structure of the solid oxide fuel cell is simpler than the other fuel cells. Further, the solid oxide fuel cell does not have electrolyte loss, replenishment, corrosion problems and does not need a precious metal catalyst so that the fuel may be directly supplied therein through internal reforming. The solid oxide fuel cell reversely performs an electrochemical reaction to be used as a high temperature hydroelectrolyzer (solid oxide electrolyzer cell: SOEC).

[0003] The electrochemical reactors such as a solid oxide fuel cell and a high temperature hydroelectrolyzer are mainly classified into a flat type and a cylindrical type depending on the shape. The flat type has an advantage of a high power density (output), but also has disadvantages in that a gas sealing area is large, a thermal shock is caused by a difference in thermal expansion coefficients between materials during the lamination, and it is not easy to increase a size. Further, the cylindrical type has advantages in that the resistance against the thermal stress and the mechanical strength are relatively high and it is possible to increase the size using extrusion molding, but also has a limitation in that the power density (output) is low.

[0004] A flat tubular electrochemical reactor (a flat tubular solid oxide fuel cell) which introduces the advantages of the flat type and cylindrical type electrochemical reactors may implement a desired output performance by laminating a plurality of unit cells (single cells or unit cells) to increase a power density.

[0005] However, due to the load distribution problem caused in accordance with the lamination of the plurality of cells, a slippage of the sealant formed in a portion where a cell stack is sealed may occur, so that gas leakage and heat generation are generated to collapse the stack stability, which degrades the performance of the cell.

[0006] Accordingly, there is a need for development of a technology for performing electrical contact between unit cells and gas sealing between a fuel electrode and an air electrode.

[Related Art Document]

[Patent Document]

[0007] Korean Registered Patent Publication No. 10-1503458 (Published on March 11, 2015).

[0008] US 2016/372778 A1 discloses a flat-plate-type fuel cell stack including a plurality of plate-shaped stacked fuel cells each including an electrolyte layer, an anode, and a cathode. The fuel cell stack includes at least one of a fuel manifold communicating with a space adjacent to the anode and an oxidant manifold communicating with a space adjacent to the cathode. A compression seal member and a glass seal member are disposed around the at least one manifold.

[0009] US 2004/1 85321 A1 discloses that a solid oxide fuel cell stack having a compression plate and a terminal fuel cell includes a current collector plate comprising a substantially solid planar element disposed immediately adjacent the compression plate; an gas-impermeable interconnect plate disposed immediately adjacent and in electrical contact with the terminal fuel cell; and a compressible electrically conductive element in electrical contact with the interconnect plate and the current collector plate.

SUMMARY

[0010] An object of the present disclosure is to provide a solid oxide fuel cell or water electrolysis cell using an integrated current collector which prevents wobbling and slipping phenomenon caused by a load due to the stack lamination, by laminating cell stacks of s solid oxide fuel cell with a current collector in which a filler equipped in a sealing unit is integrally formed.

[0011] Further, another object of the present disclosure is to provide a solid oxide fuel cell or water electrolysis cell using an integrated current collector which increases a convenience for manufacturing a cell stack and a structural stability by shortening a coupling process of a sealing unit.

[0012] Technical problems of the present disclosure are not limited to the above-mentioned technical problem(s), and other technical problem(s), which is (are) not mentioned above, can be clearly understood by those skilled in the art from the following descriptions.

[0013] A solid oxide fuel cell using an integrated current collector according to claim 1 is provided. Further embodiments are described in the dependent claims. A solid oxide fuel cell using an integrated current collector includes at least one unit cell including a fuel electrode, an electrolyte film, and an air electrode; a first current collector and a second current collector which are provided on both surfaces of the at least one unit cell and have a filling unit integrally formed at both ends of a body; and a sealing unit formed on both surfaces of the filling unit.

[0014] Further, the solid oxide fuel cell using an integrated current collector according to an exemplary embodiment of the present disclosure may further include: a first housing formed on the other surface of the first current collector and a second housing formed on one surface of the second current collector to support the at least one unit cell.

[0015] Further, according to one exemplary embodiment of the present disclosure, the filling unit and the sealing unit include a hole formed to penetrate in a thickness direction to move fuel gas flowing to the at least one unit cell therethrough, and a hole equipped in the filling unit and a hole equipped in the sealing unit may communicate with each other.

[0016] A thickness of the first current collector or the second current collector satisfies the following Equation 1.

[Equation 1]

Thickness of first current collector or second current collector = Thickness of filling unit +

(Thickness of sealing unit × 2)

[0017] Further, according to one exemplary embodiment of the present disclosure, the sealing unit may be formed on both surfaces of the filling unit using one of a bonding process, a screen printing process, and a dispenser process.

[0018] The solid oxide fuel cell is a flat tubular type.

[0019] Further, a manufacturing method of a solid oxide fuel cell using an integrated current collector according to claim 5 is provided. Further embodiments are described in the dependent claims. A manufacturing method of a solid oxide fuel cell using an integrated current collector is a manufacturing method of a solid oxide fuel cell including at least one unit cell in which a fuel electrode, an electrolyte film, and an air electrode are laminated. The method includes: preparing a first current collector and a second current collector in which a filling unit is integrally formed at both ends of a body; coupling a sealing unit onto both surfaces of the filling unit; and coupling the first current collector and the second current collector onto both surfaces of the at least one unit cell to manufacture the solid oxide fuel cell.

[0020] Further, the manufacturing method of a solid oxide fuel cell using an integrated current collector according to the exemplary embodiment of the present disclosure may further include: coupling a first housing onto the other surface of the first current collector and coupling a second housing onto one surface of the second current collector to support the at least one

unit cell.

[0021] Further, according to one exemplary embodiment of the present disclosure, during the coupling of a sealing unit onto both surfaces of the filling unit, one of a bonding process, a screen printing process, and a dispenser process may be used.

[0022] Further, a thickness of the first current collector or the second current collector satisfies the following Equation 1.

[Equation 1]

$$\text{Thickness of first current collector or second current collector} = \text{Thickness of filling unit} +$$

(Thickness of sealing unit \times 2)

A solid oxide water electrolysis cell using an integrated current collector according to another exemplary embodiment of the present disclosure includes at least one unit cell including a hydrogen electrode, an electrolyte film, and an air electrode, a first current collector and a second current collector which are provided on both surfaces of the at least one unit cell and have a filling unit integrally formed at both ends of a body, and a sealing unit formed on both surfaces of the filling unit.

[0023] Specific items of other embodiments are included in the detailed description and the drawings.

[0024] According to the exemplary embodiment of the present disclosure, the cell stack of the solid oxide fuel cell is laminated by implementing a current collector in which a filler equipped in a sealing unit is integrally formed, to prevent wobbling and slipping phenomenon caused by a load due to the stack lamination.

[0025] According to the exemplary embodiment, the coupling process of the sealing unit is shortened to enhance the convenience for manufacturing the cell stack and the structural stability.

BRIEF DESCRIPTION OF THE DRAWINGS

[0026] The above and other aspects, features and other advantages of the present disclosure will be more clearly understood from the following detailed description taken in conjunction with the accompanying drawings, in which:

FIG. 1 is a view illustrating an assembling component of a cell stack used in the related art;

FIG. 2 is a plan view illustrating an integrated current collector according to an exemplary embodiment of the present disclosure;

FIG. 3 is an exploded perspective view illustrating a solid oxide fuel cell equipped with a separable current collector used in the related art;

FIG. 4 is an exploded perspective view illustrating a solid oxide fuel cell with an integrated current collector according to an exemplary embodiment of the present disclosure;

FIGS. 5A to 5C are cross-sectional views illustrating structures of a filling unit and a sealing unit formed at both ends of an integrated current collector, according to an exemplary embodiment of the present disclosure;

FIG. 6 is a flowchart illustrating a manufacturing method of a solid oxide fuel cell using an integrated current collector according to an exemplary embodiment of the present disclosure; and

FIGS. 7 and 8 are flowcharts illustrating a manufacturing method of a solid oxide fuel cell of FIG. 6 in detail.

DETAILED DESCRIPTION OF THE PREFERRED EMBODIMENT

[0027] Advantages and characteristics of the present disclosure and/or a method of achieving the advantages and characteristics will be clear by referring to exemplary embodiments described below in detail together with the accompanying drawings. However, the present disclosure is not limited to the following exemplary embodiments but may be implemented in various different forms. The exemplary embodiments are provided only to complete the disclosure of the present disclosure and to fully provide a person having ordinary skill in the art to which the present disclosure pertains with the category of the disclosure, and the present disclosure will be defined by the appended claims. Like reference numerals indicate like elements throughout the specification.

[0028] Generally, a fuel cell is a high efficiency clean power generation technology which directly converts hydrogen contained in a hydrocarbon-based material such as natural gas, coal gas, and methanol and oxygen in the air into electrical energy by electrochemical reaction and is largely classified into an alkali type, a phosphate type, a molten carbonate, a solid oxide, and polymer fuel cells depending on a type of used electrolyte.

[0029] A solid oxide fuel cell (SOFC) is a fuel cell which uses solid oxide with oxygen or hydrogen ion conductivity as electrolytes and operates at the highest temperature (600 to 1000°C) among existing fuel cells. Further, all components are made of solid so that the structure of the solid oxide fuel cell is simpler than the other fuel cells. Further, the solid oxide fuel cell does not have electrolyte loss, replenishment, corrosion problems and does not need precious metal catalyst so that the fuel may be directly supplied therein through internal reforming. The solid oxide fuel cell reversely performs an electrochemical reaction to be used as a high temperature solid oxide electrolyzer cell (SOEC).

[0030] The electrochemical reactors such as a solid oxide fuel cell and a high temperature

hydroelectrolyzer are mainly classified into a flat type and a cylindrical type depending on the shape. The flat type has an advantage of a high power density (output), but also has disadvantages in that a gas sealing area is large, a thermal shock is caused by a difference in thermal expansion coefficients between materials during the lamination, and it is not easy to increase a size. Further, the cylindrical type has advantages in that the resistance against the thermal stress and the mechanical strength are relatively high and it is possible to increase the size using extrusion molding, but also has a limitation in that the power density (output) is low.

[0031] A flat tubular electrochemical reactor (a flat tubular solid oxide fuel cell) which introduces the advantages of the flat type and cylindrical type electrochemical reactors may implement a desired output performance by laminating a plurality of unit cells (single cells or unit cells) to increase a power density.

[0032] Referring to FIG. 1, a flat tubular fuel cell of the related art implements a cell stack by bonding separate current collectors 122 and 124 and sealants 126b to unit cells 130 to achieve the electrical contact between unit cells and sealing of the fuel gas between a fuel electrode and an air electrode.

[0033] In this case, when the sealant 126b having a height corresponding to a thickness of the current collectors 122 and 124, a filler 126a is used to fill the height difference to prevent the deformation of the sealant 126b due to the temperature rise in accordance with the operation of the fuel cell.

[0034] However, there is no problem when a small number of unit cells 130 is laminated, but when dozens of unit cells 130 are laminated to manufacture a large capacity of cell stack with a kW level, the sealant 126b and the filler 126a may slip and move. Therefore, the stability of the cell stack collapses to degrade the performance of the fuel cell.

[0035] Therefore, according to the present disclosure, as illustrated in FIG. 2, parts of the current collectors 122 and 124 are implemented as a filler 126a to prevent the wobbling and slipping phenomenon which may be caused after melting the sealant 126b. That is, the current collector and the filler which have been separately used in the related art are integrally manufactured.

[0036] FIG. 3 is an exploded perspective view illustrating a solid oxide fuel cell equipped with a separable current collector used in the related art, FIG. 4 is an exploded perspective view illustrating a solid oxide fuel cell with an integrated current collector according to an exemplary embodiment of the present disclosure, and FIGS. 5A to 5C are cross-sectional views illustrating structures of a filling unit and a sealing unit formed at both ends of an integrated current collector, according to an exemplary embodiment of the present disclosure.

[0037] Referring to FIG. 3, a solid oxide fuel cell equipped with a separable current collector used in the related art includes at least one unit cell 130, current collectors 122 and 124, a sealing unit 126b, a gas inlet 20a, a gas outlet 20b, and housings 112 and 124.

[0038] The flat tubular solid oxide fuel cell is classified into two types: an air electrode support type fuel cell which uses an air electrode (a cathode) as a support of the fuel cell and a fuel electrode support type fuel cell which uses a fuel electrode (an anode) as a support. Between the air electrode support type fuel cell and the fuel electrode support type fuel cell, the fuel electrode support type is an advanced type so that the current solid oxide fuel cell is being studied and developed with respect to the fuel electrode support type.

[0039] Hereinafter, the fuel electrode support type fuel cell will be mainly described.

[0040] At least one unit cell 130 may be configured by sequentially laminating a fuel electrode, an electrolyte film, and an air electrode from an inside (or a lower side).

[0041] In the air electrode, electrons supplied from the outside and oxygen or oxygen gas in the air react with each other to form oxygen ions. The electrolyte film serves as a moving passage of oxygen ions formed in the air electrode and block the direct contact between air and the fuel and block the movement of the electrons. Further, the fuel electrode serves to send electrons generated when the oxygen ion transmitted through the electrolyte film and the fuel cause electrochemical reaction, to the outside.

[0042] Specifically, the fuel electrode is supplied with oxygen or oxygen gas in the air and the electron supplied from the fuel electrode is combined with the oxygen to form an oxygen ion. When the oxygen ion moves through the electrolyte film to reach the fuel electrode, the oxygen ion reacts with hydrogen gas which is a fuel to generate water and discharge electrons. As a result, the electrons generated in the fuel electrode flow to the external circuit to generate current to generate electricity.

[0043] For reference, holes which are formed to penetrate in a thickness direction are formed at both ends of the unit cell 130 to introduce and discharge the fuel gas.

[0044] The current collectors 122 and 124 include terminals which collect electricity to collect electricity formed in at least one unit cell 130.

[0045] The current collectors 122 and 124 may include a first current collector 122 located on a lowermost portion of at least one unit cell 130 and a second current collector 124 located on an uppermost portion of at least one unit cell 130.

[0046] In this case, in accordance with the structure of the unit cell 130 in which the fuel electrode, the electrolyte film, and the air electrode are sequentially laminated from the inside (or a lower side), the first current collector 122 may be a fuel electrode layer current collector and the second current collector 124 may be an air electrode layer current collector.

[0047] In the drawing, a structure of the fuel cell configured by one unit cell 130 has been illustrated and the first current collector 122 and the second current collector 124 may be

coupled onto both surfaces of the unit cell 130.

[0048] In contrast, when a plurality of unit cells 130 is laminated, the first current collector 122 is coupled to a lower portion of the lowermost unit cell 130 and the second current collector 124 is coupled to an upper portion of the uppermost unit cell 130.

[0049] The sealing units 126b are formed on both ends of the unit cell 130 and is provided in a position spaced apart from the current collectors 122 and 124 with a predetermined interval. That is, the sealing units 126b may be formed on upper portion and lower portion of both ends of the unit cell 130 and may be equipped in the unit cell 130 to be separated from the current collectors 122 and 124.

[0050] The sealing unit 126b may include a filling unit 126a to fill the height difference to prevent the deformation of the sealant due to the temperature rise in accordance with the operation of the fuel cell.

[0051] That is, the sealing unit 126b may be implemented such that sealing members are coupled onto both surfaces of the filling unit 126a. For reference, as the sealing member, a glass sealant may be used, and, as the filling unit 126a, crofer or yttria stabilized zirconia (YSZ) may be used.

[0052] The housings 112 and 114 are frames used to support at least one unit cell 130 and may be formed at the outside of the current collectors 122 and 124.

[0053] For example, the housings 112 and 114 includes a first housing 112 coupled to the other surface, that is, a lower portion of the first current collector 122 and a second housing 114 which is coupled to one surface, that is, an upper portion of the second current collector 124.

[0054] The housings 112 and 114 are desirably implemented by a metal material which minimizes deformation at a high temperature.

[0055] In the housings 112 and 114, a gas inlet which introduces fuel gas flowing to the unit cell 130 and a gas outlet which discharges the fuel gas.

[0056] For example, the gas inlet may be connected to the first housing 112 and the gas outlet may be connected to the second housing 114 and the positions of the gas inlet and the gas outlet may be changed in accordance with a laminating order of the fuel electrode, the electrolyte film, and the air electrode of the unit cell 130.

[0057] For reference, the first housing 112 and the second housing 114 may further include an electric terminal 10 connected to the outside.

[0058] The solid oxide fuel cell of the related art with the above-described structure is

configured by the current collectors 122 and 124 and the sealing unit 126b which are separately formed so that the following problems may occur.

[0059] There is no problem when a small number of unit cells 130 is laminated in the fuel cell, but when dozens of unit cells 130 are laminated to manufacture a large capacity of cell stack with a kW level, the sealing unit 126b and the filling unit 126a may slip and move. Therefore, the stability of the cell stack collapses to degrade the performance of the fuel cell.

[0060] Referring to FIG. 4, a solid oxide fuel cell 100 with an integrated current collector according to an exemplary embodiment of the present disclosure includes at least one unit cell 130, current collectors 122 and 124, a sealing unit 126b, a gas inlet, a gas outlet, and a housing.

[0061] The at least one unit cell 130, the gas inlet, the gas outlet, and the housing of the solid oxide fuel cell 100 according to the exemplary embodiment of the present disclosure performs the same functions as the at least one unit cell 130, the gas inlet 20a, the gas outlet 20b, and the housings 112 and 114 of the solid oxide fuel cell of the related art so that only the current collectors 122 and 124 and the sealing unit 126b will be described below.

[0062] The current collectors 122 and 124 include terminals which collect electricity to collect electricity formed in at least one unit cell 130.

[0063] The current collectors 122 and 124 may include a first current collector 122 located on a lowermost portion of at least one unit cell 130 and a second current collector 124 located on an uppermost portion of at least one unit cell 130.

[0064] In this case, in accordance with the structure of the unit cell 130 in which the fuel electrode, the electrolyte film, and the air electrode are sequentially laminated from the inside (or a lower side), the first current collector 122 may be a fuel electrode layer current collector and the second current collector 124 may be an air electrode layer current collector.

[0065] In the drawing, a structure of the fuel cell configured by one unit cell 130 has been illustrated and the first current collector 122 and the second current collector 124 may be coupled to both surfaces of the unit cell 130.

[0066] In contrast, when a plurality of unit cells 130 is laminated, the first current collector 122 is coupled to a lower portion of the lowermost unit cell 130 and the second current collector 124 is coupled to an upper portion of the uppermost unit cell 130.

[0067] In the collectors 122 and 124, filling units 126a may be integrally formed with both ends of the bodies.

[0068] That is, unlike the current collectors 122 and 124 of the related art which are implemented to be separated from the filling unit 126a included in the sealing unit 126b, the

current collector 122 and 124 of the present disclosure may implement both ends of the body as filling units 126a.

[0069] The sealing units 126b may be formed on both surfaces of the filling unit 126a. In other words, the sealing units 126b may be formed to be coupled onto both surfaces of the filling unit 126a.

[0070] The filling unit 126a and the sealing unit 126b may include holes which are formed to penetrate in a thickness direction to move a fuel gas flowing to the at least one unit cell 130 therethrough.

[0071] In this case, the hole equipped in the filling unit 126a and the hole equipped in the sealing unit 126b may communicate with each other.

[0072] A thickness h of the current collectors 122 and 124 may satisfy the following Equation 1 with regard to a thickness h_1 of the sealing unit 126b and a thickness h_2 of the filling unit 126a.

[Equation 1]

Thickness h of first current collector 122 or second current collector 124 = Thickness h_2 of

filling unit 126a + (Thickness h_1 of sealing unit 126b \times 2)

[0073] As illustrated in FIGS. 5A and 5B, the thickness of the first current collector 122 or the second current collector 124 may be desirably equal to a thickness obtained by adding all a thickness of the sealing unit 126b formed on a top surface of the filling unit 126a, a thickness of the sealing unit 126b formed on a bottom surface of the filling unit 126a and a thickness of the filling unit 126a. FIGS. 5A and 5B are examples formed with an A-type current collector structure. The A-type current collector is formed such that the first current collector and the second current collector and the filling unit (spacer) are integrally formed as a current collector, and the filling unit which is integrally formed with the first current collector or the second current collector is not a rectangular shape. In this case, as illustrated in FIG. 5A, the integrated current collector may be formed to include only a filler area in which the sealing unit 126b is formed or as illustrated in FIG. 5B, the integrated current collector may be formed such that a filler area in which the sealing unit 126b is formed and a filler area in which a metallic foam is formed are divided.

[0074] FIG. 5C illustrates a B-type current collector, and the B-type current collector is formed such that the first current collector and the second current collector and a filling unit (spacer) are integrally formed as a current collector, and the integrated current collector has a rectangular shape. Referring to FIG. 5C, the thickness of the sealing unit 126b is the same as the thickness of the metallic foam.

[0075] The metallic foam has a high conductivity and sufficient porosity and even though the thickness changes due to the compression of the sealing material, the conduction and gas permeation may be easily performed. Desirably, the metallic foam may be formed by silver

(Ag) metallic foam. In this case, the thickness h of the first collector 122 or the second current collector 124 may be a value obtained by adding the thickness h_2 of the filling unit 126a and twice the thickness h_1 of the sealing unit 126b, and the thickness of the metallic foam may be larger or smaller than h_1 depending on whether the current collector is the A type or B type.

[0076] Accordingly, since the thickness of the current collectors 122 and 124 is uniformly formed in a center portion and both ends so that the unit cell 130 may be more stably supported. Further, the wobbling and slipping phenomenon which may be generated when the plurality of unit cells 130 is laminated may be prevented.

[0077] The sealing unit 126b may be formed on both surfaces of the filling unit 126a by performing a screen printing process using a sticker type or adhesive type sealing member.

[0078] Further, the sealing unit 126b may be formed on both surfaces of the filling unit 126a by performing a dispenser process of squeezing an elastic sealing member injected into a syringe or a tube.

[0079] Further, the sealing unit 126b may be formed on both surfaces of the filling unit 126a by performing a coating process using a roll or a transfer plate.

[0080] Further, the sealing unit 126b may be formed on both surfaces of the filling unit 126a by performing a bonding process using an adhesive.

[0081] As described above, according to the exemplary embodiment, the coupling process of the sealing unit 126b is shortened to enhance the convenience for manufacturing the cell stack and the structural stability.

[0082] FIG. 6 is a flowchart illustrating a manufacturing method of a solid oxide fuel cell using an integrated current collector according to an exemplary embodiment of the present disclosure; and FIGS. 7 and 8 are flowcharts illustrating a manufacturing method of a solid oxide fuel cell of FIG. 6 in detail.

[0083] Referring to FIGS. 4 and 6, in step S610, a manufacturing apparatus of a solid oxide fuel cell using an integrated current collector according to an exemplary embodiment of the present disclosure may prepare a first current collector 122 and a second current collector 124 with a filling unit 126a integrally formed at both ends of a body.

[0084] In this case, at least one unit cell 130 in which a fuel electrode, an electrolyte film and an air electrode are laminated may be further prepared to be coupled with the first current collector 122 and the second current collector 124.

[0085] The first current collector 122 and the second current collector 124 are devices which collect electricity formed in at least one unit cell 130 and include the filling unit 126a integrally formed at both ends of the body.

[0086] Next, in step S620, the manufacturing apparatus of a solid oxide fuel cell using an integrated current collector according to the exemplary embodiment of the present disclosure couples the sealing unit 126b onto both surfaces of the filling unit 126a.

[0087] Here, the sealing unit 126b may be coupled onto both surfaces of the filling unit 126a using one of a bonding process, a screen printing process, and a dispenser process.

[0088] In this case, a thickness of the first current collector 122 or the second current collector 124 implemented by forming the sealing unit 126b on both surfaces of the filling unit 126a may satisfy the following Equation 1.

[Equation 1]

$$\text{Thickness of first current collector 122 or second current collector 124} = \text{Thickness of filling unit 126a} + (\text{Thickness of sealing unit 126b} \times 2)$$

[0089] That is, the thickness of the first current collector 122 or the second current collector 124 may be desirably equal to a thickness obtained by adding a thickness of the sealing unit 126b formed on a top surface of the filling unit 126a and a thickness of the sealing unit 126b formed on a bottom surface of the filling unit 126a and a thickness of the filling unit 126a.

[0090] Next, in step S630, the manufacturing apparatus of a solid oxide fuel cell using an integrated current collector according to the exemplary embodiment of the present disclosure may manufacture the solid oxide fuel cell by coupling the first current collector 122 and the second current collector 124 onto both surfaces of at least one unit cell 130.

[0091] In the meantime, according to the exemplary embodiment, in order to support at least one unit cell 130, a step of coupling a first housing 112 to the other surface of the first current collector 122 and coupling a second housing 114 to one surface of the second current collector 124 may be further included.

[0092] The housings 112 and 114 are frames used to support at least one unit cell 130 and the first housing 112 is coupled to the other surface, that is, a lower portion of the first current collector and the second housing 114 is coupled to one surface, that is, an upper portion of the second current collector 124.

[0093] Step S630 will be described in more detail below by reflecting the step of coupling the first housing 112 and the second housing 114.

[0094] According to an exemplary embodiment, referring to FIGS. 4 and 7, in step S632a, the manufacturing apparatus of a solid oxide fuel cell using an integrated current collector according to the exemplary embodiment of the present disclosure may couple the first current collector 122 onto one surface of the first housing 112, that is, a top surface.

[0095] Next, in step S634a, the manufacturing apparatus of a solid oxide fuel cell using an integrated current collector according to the exemplary embodiment of the present disclosure may couple the unit cell 130 onto one surface of the first current collector 122, that is, a top surface.

[0096] Next, in step S636a, the manufacturing apparatus of a solid oxide fuel cell using an integrated current collector according to the exemplary embodiment of the present disclosure may couple the second current collector 124 onto one surface of the unit cell 130.

[0097] Next, in step S638a, the manufacturing apparatus of a solid oxide fuel cell using an integrated current collector according to the exemplary embodiment of the present disclosure may couple the second housing 114 onto one surface of the second current collector 124 to manufacture a solid oxide fuel cell.

[0098] That is, according to the present exemplary embodiment, the first current collector 122, the unit cell 130, and the second current collector 124 are sequentially coupled between the first housing 112 and the second housing 114 to manufacture a solid oxide fuel cell.

[0099] According to another exemplary embodiment, referring to FIGS. 4 and 8, in step S632b, the manufacturing apparatus of a solid oxide fuel cell using an integrated current collector according to an exemplary embodiment of the present disclosure may couple the first current collector 122 and the second current collector 124 onto both surfaces of the unit cell 130.

[0100] Next, in step S634b, the manufacturing apparatus of a solid oxide fuel cell using an integrated current collector according to the exemplary embodiment of the present disclosure may couple the unit cell 130 onto one surface of the first housing 112, that is, a top surface.

[0101] Next, in step S636b, the manufacturing apparatus of a solid oxide fuel cell using an integrated current collector according to the exemplary embodiment of the present disclosure may couple the second housing 114 onto one surface of the unit cell 130 to manufacture a solid oxide fuel cell.

[0102] That is, according to the present exemplary embodiment, the first current collector 122 and the second current collector 124 are coupled onto both surfaces of the unit cell 130 first, and then coupled between the first housing 112 and the second housing 114.

[0103] In the above embodiments, the fuel electrode of the at least one unit cell is constituted into a hydrogen electrode, and other configurations and function are equally applied to the solid oxide water electrolysis cell. Namely, the solid oxide fuel cell reversely performs an electrochemical reaction to be used as a solid oxide electrolyzer cell (SOEC).

[0104] Although a specific exemplary embodiment of the present disclosure has been described, it should be understood that various modifications may be made therein without departing from the scope of the present disclosure. Therefore, the scope of the present

disclosure should not be limited to the described embodiment, but should be determined by the claims to be described below and equivalents thereof.

REFERENCES CITED IN THE DESCRIPTION

Cited references

This list of references cited by the applicant is for the reader's convenience only. It does not form part of the European patent document. Even though great care has been taken in compiling the references, errors or omissions cannot be excluded and the EPO disclaims all liability in this regard.

Patent documents cited in the description

- KR101503458 [0007]
- US2016372778A1 [0008]
- US2004185321A1 [0009]

P A T E N T K R A V

1. Fastoxid-brændselscelle, som anvender en integreret strømkollektor, omfattende:

5

mindst en enhedscelle, som indbefatter en brændselselektrode, en elektrolytfilm og en luftelektrode;

10

en første strømkollektor og en anden strømkollektor, som er tilvejebragt på begge overflader af den mindst ene enhedscelle og har en påfyldningsenhed, som er integreret dannet ved begge ender af en krop; og

15

en tætningsenhed dannet ved at kombinere tætningselementer på begge overflader af påfyldningsenheden,

hvor fastoxid-brændselscellen er en flad rørformet type, og

hvor en tykkelse af den første strømkollektor eller den anden strømkollektor opfylder følgende ligning 1:

[Ligning 1]

Tykkelse af første strømkollektor eller anden strømkollektor = Tykkelse af påfyldningsenhed + (Tykkelse af tætningsenhed x 2).

20

2. Fastoxid-brændselscelle ifølge krav 1, som endvidere omfatter:

et første hus dannet på den anden overflade af den første strømkollektor og et andet hus dannet på en overflade af den anden strømkollektor for at støtte den mindst ene celleenhed.

25

3. Fastoxid-brændselscelle ifølge krav 1, hvor påfyldningsenheden og tætningsenheden indbefatter et hul dannet til at gennemtrænge i en tykkelsesretning for at bevæge gas, som strømmer til den mindst ene enhedscelle, derigennem, og et hul tilvejebragt i påfyldningsenheden og et hul tilvejebragt i tætningsenheden kommunikerer med hinanden.

30

4. Fastoxid-brændselscelle ifølge krav 1, hvor tætningsenheden er dannet på begge overflader af påfyldningsenheden ved anvendelse af en bondingproces, en serigrafiprocess og en dispenserproces.

5 5. Fremstillingsfremgangsmåde til en fastoxid-brændselscelle, som indbefatter mindst en enhedscelle, hvori en brændselselektrode, en elektrolytfilm og en luft-elektrode er lamineret, hvor fastoxid-brændselscellen er en flad rørformet type, hvor fremstillingsfremgangsmåden omfatter:

10 at fremstille en første strømkollektor og en anden strømkollektor, hvori en påfyldningsenhed er integreret dannet ved begge ender af en krop;
at koble en tætningsenhed til begge overflader af påfyldningsenheden ved at kombinere tætningselementer; og
at koble den første strømkollektor og den anden strømkollektor til begge
15 overflader af den mindst ene enhedscelle for at fremstille fastoxid-brændselscellen,
hvor en tykkelse af den første strømkollektor eller den anden strømkollektor opfylder følgende ligning 1:

20 [Ligning 1]
Tykkelse af første strømkollektor eller anden strømkollektor = Tykkelse af påfyldningsenhed + (Tykkelse af tætningsenhed x 2).

25 6. Fremstillingsfremgangsmåde til en fastoxid-brændselscelle ifølge krav 5, som endvidere omfatter:
at koble et første hus til den anden overflade af den første strømkollektor og at koble et andet hus til en overflade af den anden strømkollektor for at støtte den mindst ene enhedscelle.

7. Fremstillingsfremgangsmåde til en fastoxid-brændselscelle ifølge krav 5, hvor der under koblingen af en tætningsenhed til begge overflader af påfyldningsenheden anvendes en af en bondingproces, en serigrafiprocess og en dispenserproces.

DRAWINGS

[FIG. 1]

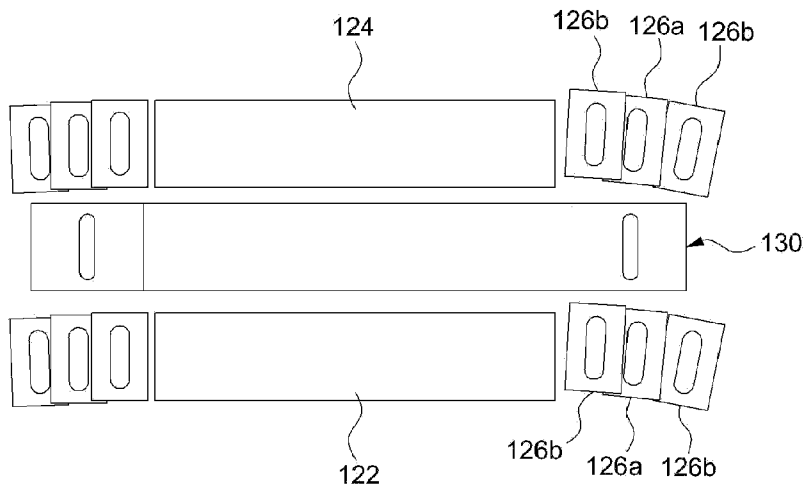

[FIG. 2]

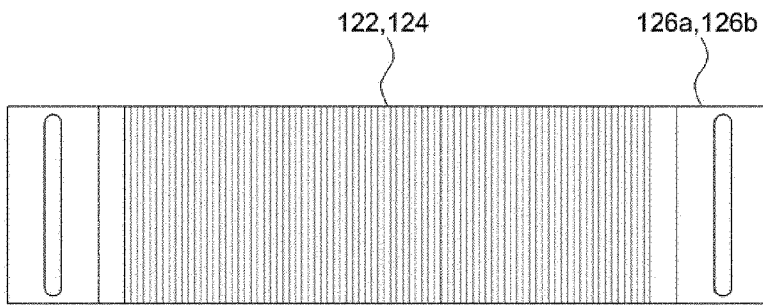

[FIG. 3]

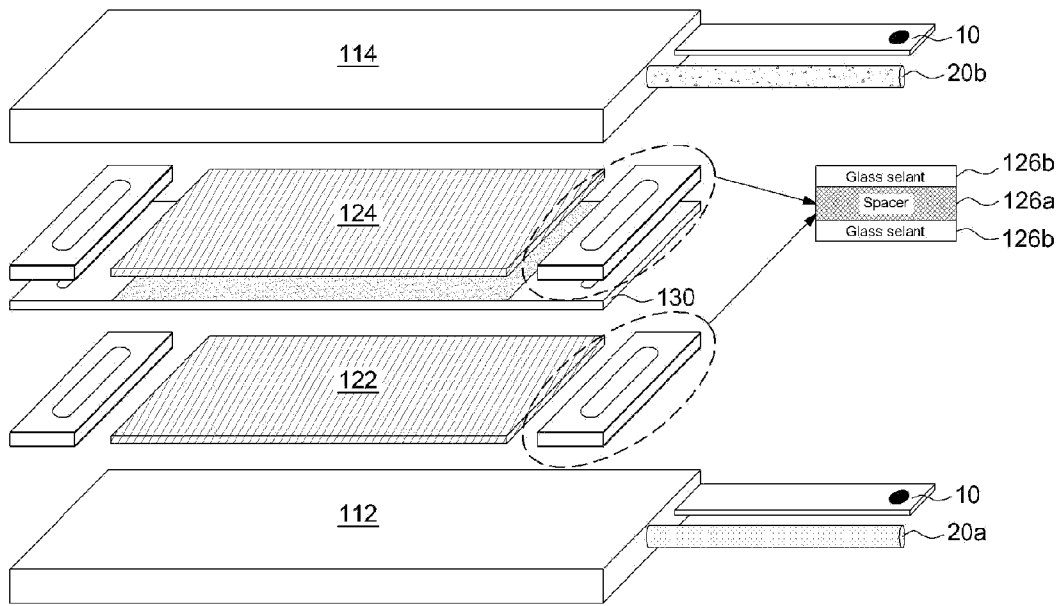

[FIG. 4]

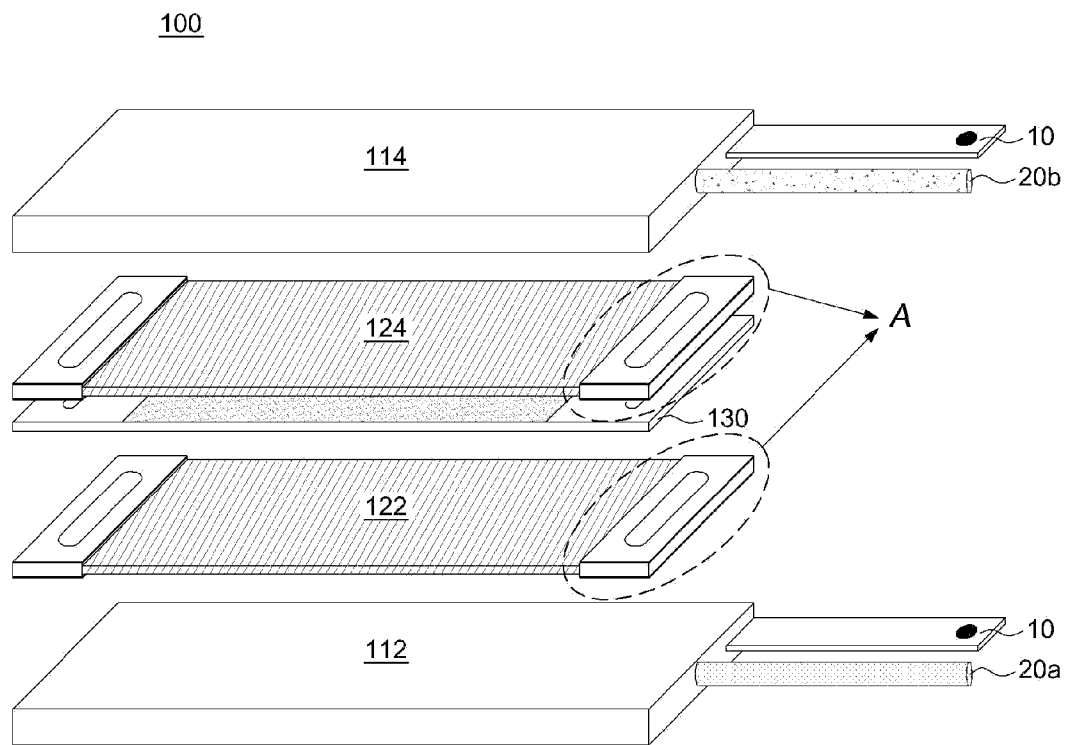

[FIG. 5A]

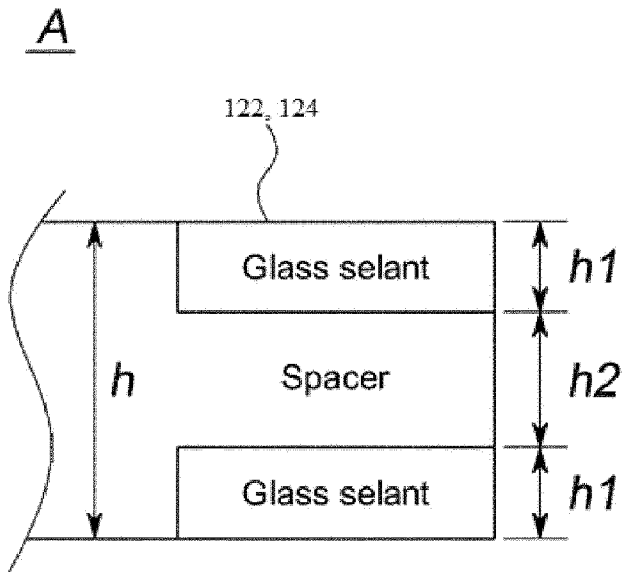

[FIG. 5B]

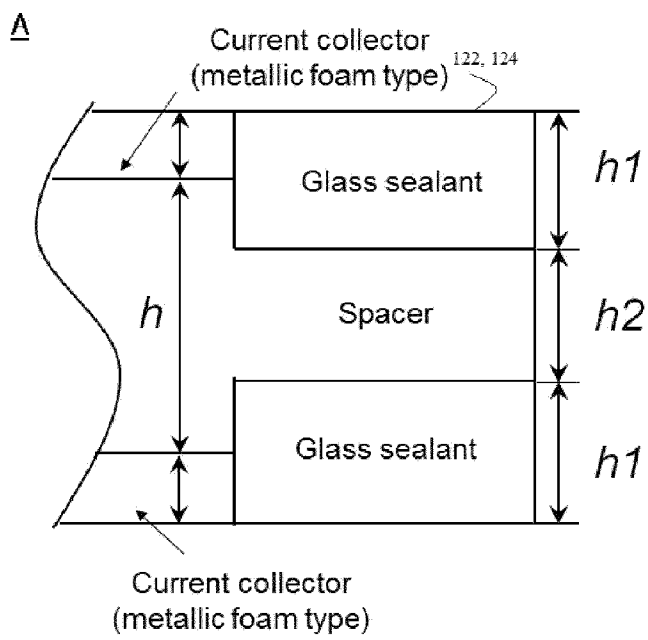

[FIG. 5C]

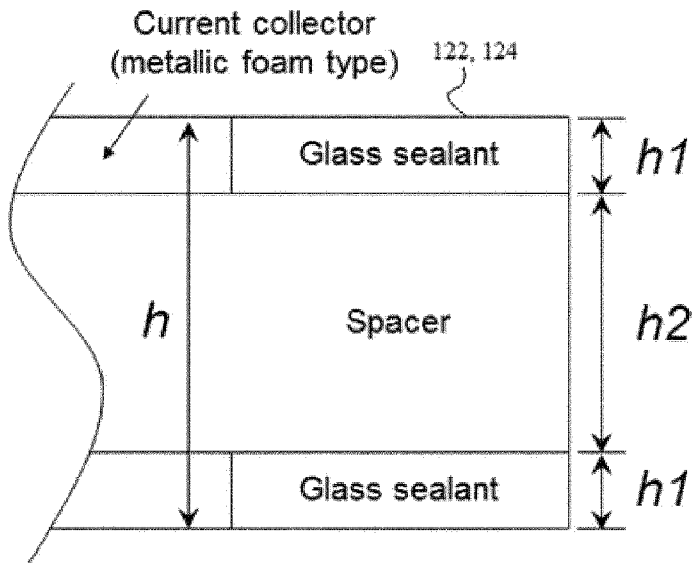
B

[FIG. 6]

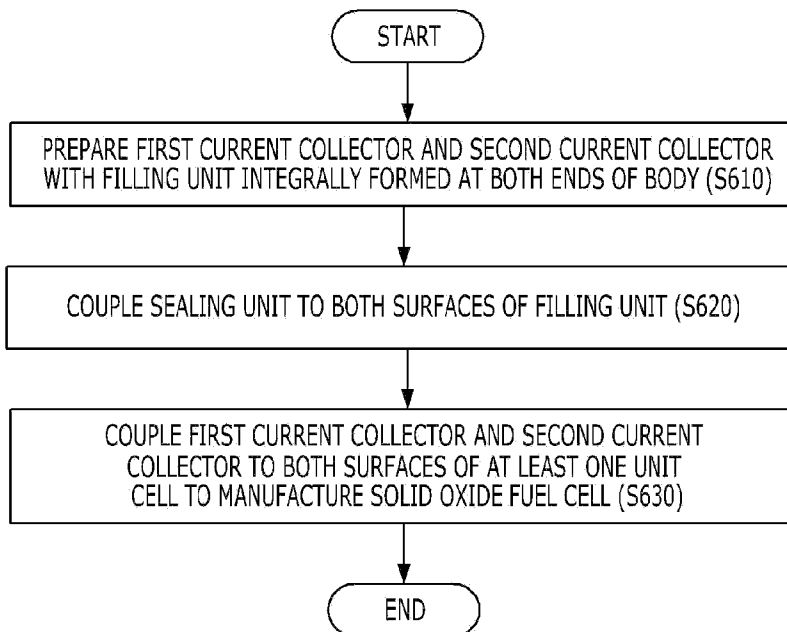

[FIG. 7]

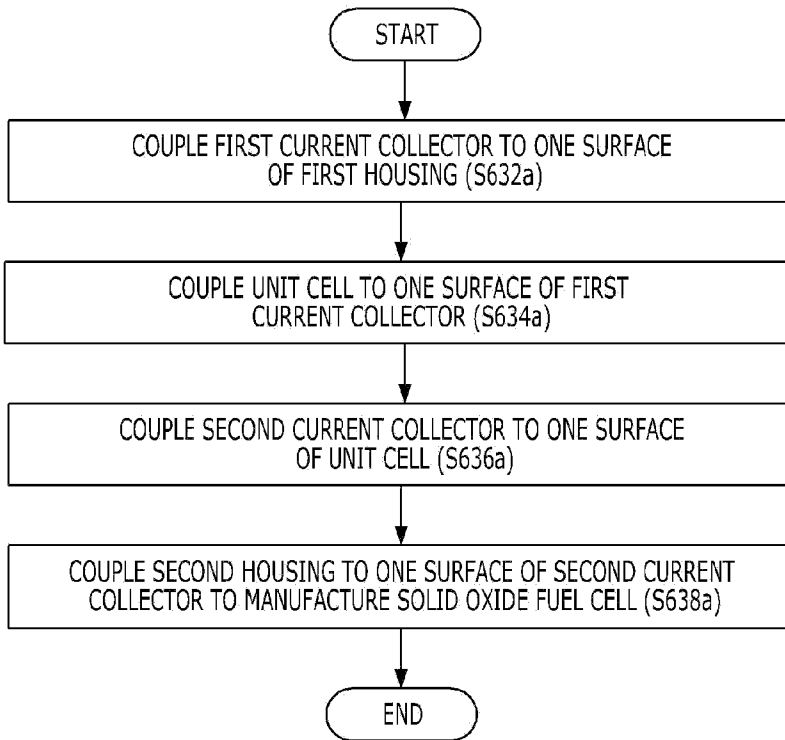

[FIG. 8]

