

- [54] SWIMMING FINS
- [75] Inventor: **Juan Vilarrubis**, Barcelona, Spain
- [73] Assignee: **Nemrod-Metzeler, S.A.**, Barcelona, Spain
- [22] Filed: **Aug. 12, 1970**
- [21] Appl. No.: **63,062**
- [30] **Foreign Application Priority Data**
Apr. 8, 1970 Spain 378332
- [52] U.S. Cl. **9/309**
- [51] Int. Cl.² **A63B 31/10**
- [58] Field of Search 9/309
- [56] **References Cited**
UNITED STATES PATENTS
3,183,529 5/1965 Beuchat 9/309

3,302,222 2/1967 Ferraro 9/309

Primary Examiner—Trygve M. Blix
Assistant Examiner—Gregory W. O'Connor
Attorney, Agent, or Firm—Brumbaugh, Graves, Donohue & Raymond

[57] **ABSTRACT**

A swimming fin to be worn on the foot of the swimmer and having a passage extending longitudinally through the fin from at least one surface remote from the free end of the fin and terminating at the free end of the fin, the passage having a larger crosssectional area at the discharge end than at the inlet end to draw water into the passage and discharge it from the free end of the fin to facilitate its use and impart thrust to the swimmer.

17 Claims, 5 Drawing Figures

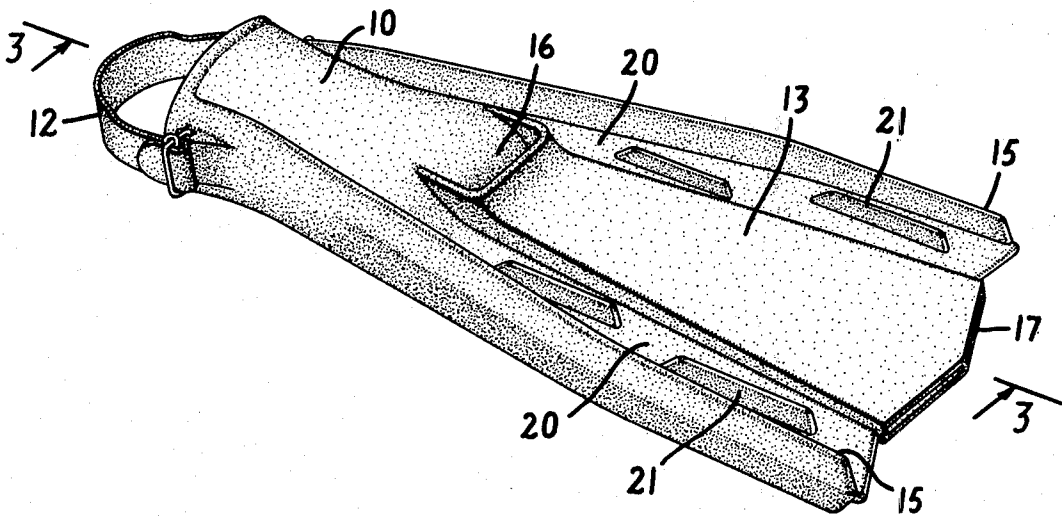

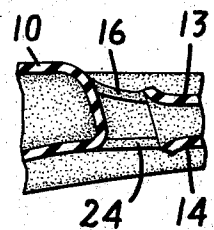
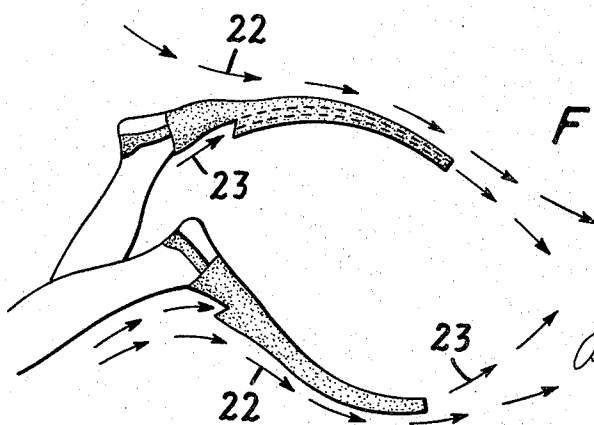
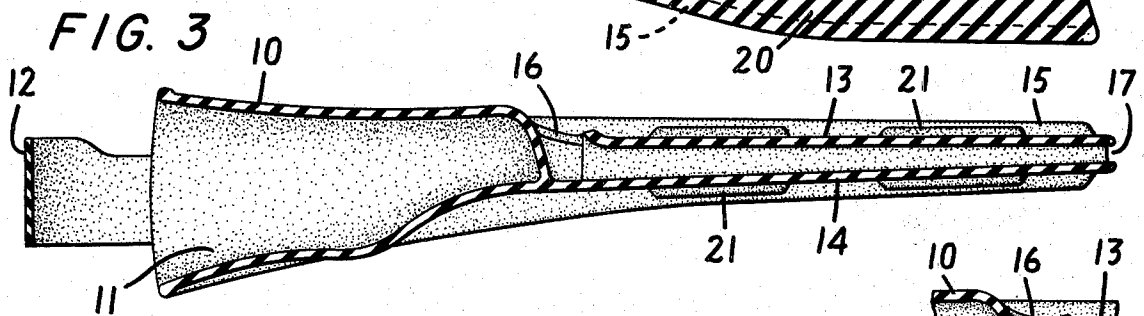
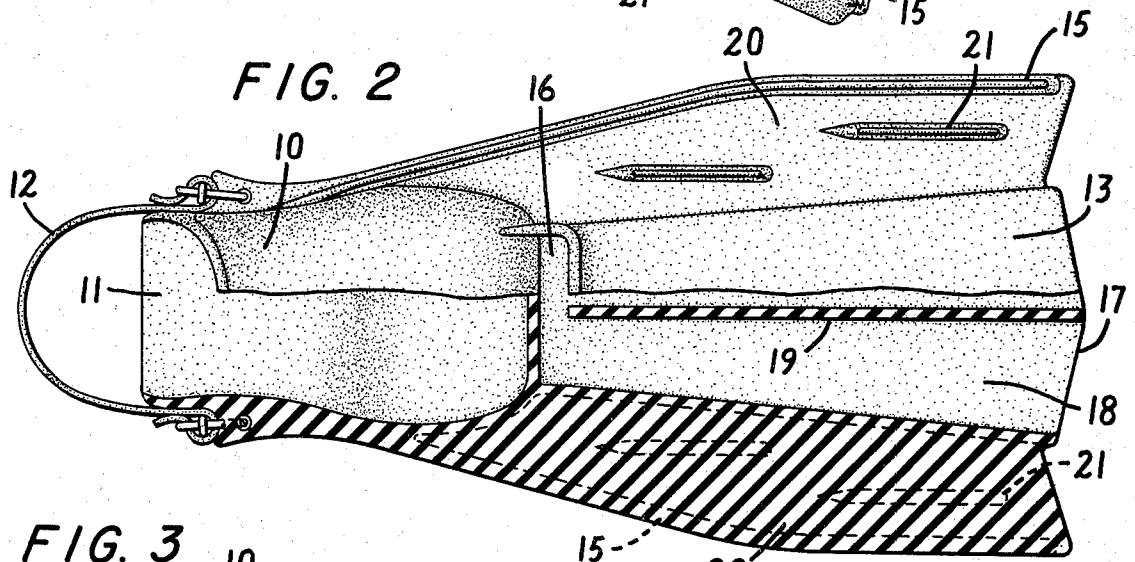
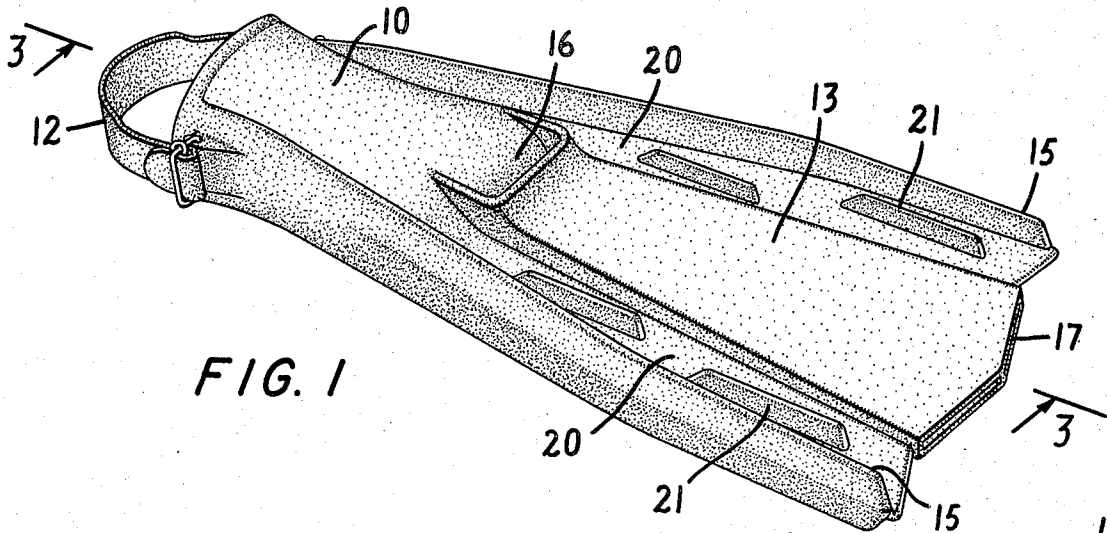

FIG. 4

FIG. 5

INVENTOR.
JUAN VILARRUBIS

BY
Brumbaugh, Lave, Donhue & Raynold
his ATTORNEYS

SWIMMING FINS

This invention relates to foot-worn swimming fins, and more particularly to an improved swimming fin which is easier to use, produces greater thrust or propulsion for the swimmer and affords greater stability than conventional swimming fins.

The swimming fin of the present invention has a passage extending longitudinally through the fin from an inlet remote from the free end of the fin on at least one side thereof to a discharge at the free end of the fin, the discharge being of greater cross-sectional area than the inlet so that in the ordinary use of the fin in swimming, water will be drawn into the inlet and discharged from the free end of the fin to facilitate the kicking action of the swimmer and to impart additional thrust to the swimmer.

The swimming fin of the present invention is also provided with a series of stabilizing vanes spaced apart along the upper and lower surfaces of the fin on both sides of the central portion of the fin to afford a greater stability to the fin when it is in use. The stabilizers on each side of the fin extend generally longitudinally of the fin and are preferably not in alignment. In use the stabilizers help to maintain the fins in proper orientation with respect to the water and to prevent wobble or other erratic movements of the fin which result in loss of propulsion or thrust.

For a more complete understanding of the present invention, reference may be made to the detailed description which follows and to the accompanying drawings, in which:

FIG. 1 is a prospective view of the swimming fin of the present invention;

FIG. 2 is a plan view with a portion broken away and shown in cross section,

FIG. 3 is a view taken along the line 3—3 of FIG. 1 looking in the direction of the arrows;

FIG. 4 is a schematic view which illustrates the operation of the swimming fin; and

FIG. 5 is a fragmentary cross-sectional view illustrating an alternative embodiment of the present invention.

Referring to the drawings, the swimming fin of the present invention has a foot-receiving portion 10 at one end having a foot cavity or pocket 11 therein. The fin can be conventionally formed of a single mass of elastomeric material and is held on the foot by an ankle strap 12. This particular structure of the fin forms no part of the present invention, and other means for anchoring the fin to the foot of the swimmer can also be used.

A wall extends longitudinally beyond the foot to provide a relatively long and wide fin having relatively large upper and lower surfaces 13 and 14, respectively. Vertically disposed reinforcing ribs 15 extend from the foot-receiving portion 10 of the fin and at least a portion of each rib diverging from each other longitudinally along the edges of the fin on both the upper and lower surfaces.

The central portion of the wall contains a longitudinally extending passage 18 which has an intake 16 on at least one of the surfaces 13 and 14 and an outlet or jet exhaust orifice 17 at the free end of the fin, that is to say, the end opposite the foot-receiving portion 10.

The fin illustrated in FIGS. 1 through 3 has a single intake or water scoop opening 16 between the foot pocket and the inner edge on the upper surface 13 of the fin. However, in the alternative embodiment of the fin illustrated in FIG. 5, an intake 16 is shown on the

upper surface 13 and another intake 24 is shown on the lower surface 14.

The longitudinal passage 18 through the fin has a larger cross-sectional area at the discharge than at the inlet. A vertically extending intermediate rib or partition 19 subdivides the passage 18 into a plurality of water passages.

On both the upper and lower surfaces of the fin there are recessed channels 20 intermediate the central portion of the fin and the edge ribs 15. These recessed channels each contain spaced-apart longitudinally extending vanes 21 which are preferably laterally offset out of alignment with each other. These stabilizers help the swimmer to maintain the fins oriented with respect to the water and prevent erratic motions which fail to generate the maximum thrust or propulsion for the swimmer.

The operation of the fins is illustrated in FIG. 4 of the drawings wherein the arrows 22 indicate the direction of the flow of water relative to the outer surfaces of the fins and the arrows 23 indicate the direction of the flow of water through the longitudinal passages of the fins. As the swimmer kicks his legs, water enters the passages 28 through the intakes 16, and as the water flows downstream and the passages increase in size, the flow draws more water into the intakes. This flow ultimately is discharged from the free ends of the fins in directions determined by the free ends. This flow of water through the fins makes the kicking action easier, affords a greater effective surface to each fin and imparts additional thrust or propulsion to the swimmer.

The invention has been shown and described in preferred forms and by way of example only, and many variations and modifications may be made in the fin within the spirit of the invention. The invention, therefore, should not be limited to any specified or one embodiment, except insofar as such form or embodiment is expressly set forth in the claims.

I claim:

1. A swimming fin to be worn on the foot of a swimmer comprising a fin portion wider and longer than the foot of the swimmer and having upper and lower surfaces and a free end, said lower surface presenting a continuous surface to the body of water, means defining a passage extending longitudinally through said fin portion out of communication with said lower surface and terminating in a discharge end of larger cross-sectional area than the inlet end, means defining an intake to said passage on the said upper surface and remote from the free end, and means defining a discharge opening at the free end of the fin portion, whereby in the ordinary use of the fin in swimming water is drawn into the passage by reason of the larger cross-sectional area at the discharge end and discharged therefrom in a direction longitudinally of the free end of the fin.

2. A swimming fin as set forth in claim 1 in which said portion of the fin is relatively flat and in which the passage gradually increases in width toward the discharge end thereof.

3. A swimming fin as set forth in claim 2 including a longitudinally extending wall within said passage to subdivide the passage and re-inforce the fin.

4. A swimming fin as set forth in claim 1 including a pair of longitudinally extending ribs extending along the side edges of the said fin portion, flow channels adjacent said longitudinally extending ribs and stabilizer

vanes upstanding in said flow channels for stabilizing the fin.

5. A swimming fin as set forth in claim 4 in which there is a plurality of stabilizing vanes within each flow channel and in which said stabilizing vanes within each channel are spaced longitudinally and out of alignment.

6. A swimming fin as set forth in claim 4 in which said stabilizing vanes are provided on said upper and lower surfaces of said fin portion.

7. A swimming fin to be worn on the foot of a swimmer comprising a foot-receiving portion, a fin portion extending longitudinally beyond said foot-receiving portion, the free end opposite said foot-receiving portion being substantially wider, an upstanding rib along both edges of the fin portion and on both the upper and lower surfaces of said fin portion, a recessed flow channel adjacent each of the said ribs and a plurality of fins in each flow channel which are spaced apart longitudinally to permit controlled flexing of the fin and laterally offset so as not to be in alignment.

8. A swimming fin as set forth in claim 7 including a longitudinally extending, relatively flat passage through the center of said fin portion having a discharge end at the free end of the fin portion of larger cross-sectional area than the inlet end of said passage and having no communication with the lower surface of the fin, means defining an intake to said passage on the upper surface of the fin remote from the free end of the fin, and means defining a discharge opening at the free end of the fin portion, whereby in the ordinary use of the fin in swimming, water is drawn into the passage by reason of the larger cross-sectional area at the discharge end and discharged therefrom in a direction longitudinally of the free end of the fin.

9. A swim fin, which comprises: wall means to define a foot pocket, first and second side ribs extending forwardly from said foot pocket wall means, at least portions of said side ribs diverging relative to each other in a direction away from said foot pocket wall means, and wall means extending between said side ribs and forming the blade of the swim fin, at least part of said blade wall means being a top wall, said top wall terminating, at the inner end portion thereof relatively adjacent said foot pocket wall means, at an inner edge which is spaced from said foot pocket wall means, said top wall terminating, at the outer end portion thereof remote from said foot pocket wall means, in a region which is adjacent the tip of said blade, at least part of said blade wall means being a bottom wall which is spaced from said top wall, said bottom wall terminating, at the outer end portion thereof remote from said foot pocket wall means, in a region which is adjacent the tip of said blade, said top and bottom walls cooperating with each other in defining at least one water passage, said water passage terminating at its inner end in a water-scoop opening which is defined in part by said inner edge of said top wall, said water passage terminating at its outer end in a jet-exhaust orifice which is defined between said outer end portions of said top and bottom walls, said orifice being directed away from said foot pocket wall means.

10. A swim fin, which comprises a blade adapted to be employed in propelling a swimmer through the water, means provided at one end of said blade to mount the same to the foot of a swimmer, water-scoop means provided on the top of said blade and directed to receive water in response to downward movement of the

foot of said swimmer when said swimmer is in a face-down position, said water-scoop means being disposed relatively adjacent said mounting means, jet-exhaust means provided at the other end of said blade remote from said mounting means, said jet-exhaust means being directed to discharge water in a direction away from said mounting means, and passage means to conduct water from said water-scoop means to said jet-exhaust means for discharge through the latter, said passage means being defined in part by upper and lower walls which extend from said water-scoop means to said other end of said blade and substantially separate the water flowing through said passage means from the water passing along the exterior of said blade.

11. The invention as claimed in claim 9, in which said jet-exhaust means comprises orifice means disposed at the extreme tip of said other end of said blade, said tip being the portion of said blade most remote from said mounting means.

12. The invention as claimed in claim 9, in which the mouth of said water-scoop means is directed transversely to the plane of said blade.

13. The invention as claimed in claim 12, in which the walls of said passage means include smoothlycurving portions adapted to change the direction of flow of water from said direction transverse to the plane of said blade to a direction in the plane of said blade.

14. A swim fin, which comprises: wall means to define a foot pocket, first and second side ribs extending forwardly from said foot pocket wall means, at least portions of said side ribs diverging relative to each other in a direction away from said foot pocket wall means, intermediate rib means located between said first and second side ribs and extending forwardly from said foot pocket wall means, a top wall connected to said side ribs and to said intermediate rib means, said top wall extending to the tip of said blade, said top wall forming the top surface of the blade of said fin, said top wall terminating, at the inner portion thereof relatively adjacent said foot pocket wall means, in inner edges which are spaced forwardly from said foot pocket wall means, and a bottom wall connected to said side ribs and to said intermediate rib means, said bottom wall extending to the tip of said blade, said bottom wall forming the bottom surface of the blade of said fin, said bottom wall being spaced from said top wall, at least portions of said bottom wall extending to said foot pocket wall means, said top and bottom walls cooperating with said side ribs and with said intermediate rib means in defining a plurality of water passages, each of said water passages terminating at its inner end in a water-scoop opening which is defined in part by one of said inner edges of said top wall, each of said water passages terminating at its outer end in a jet-exhaust orifice which is defined at the tip of said blade between the extreme outer edges of said top and bottom walls, said orifice being directed away from said foot pocket wall means.

15. The invention as claimed in claim 14, in which foot pocket wall means, said side ribs, said rib means, and said top and bottom walls are formed integrally of a single mass of elastomeric material.

16. The invention as claimed in claim 14, in which the cross-sectional shape of each of said water passages is rectangular.

17. The invention as claimed in claim 16, in which said cross-sectional shape, at blade regions remote from said foot pocket wall means, is wide in the dimension between said ribs and thin in the dimension between said top and bottom walls.