

(No Model.)

L. MILLER.
BOX TOP.

No. 525,917.

Patented Sept. 11, 1894.

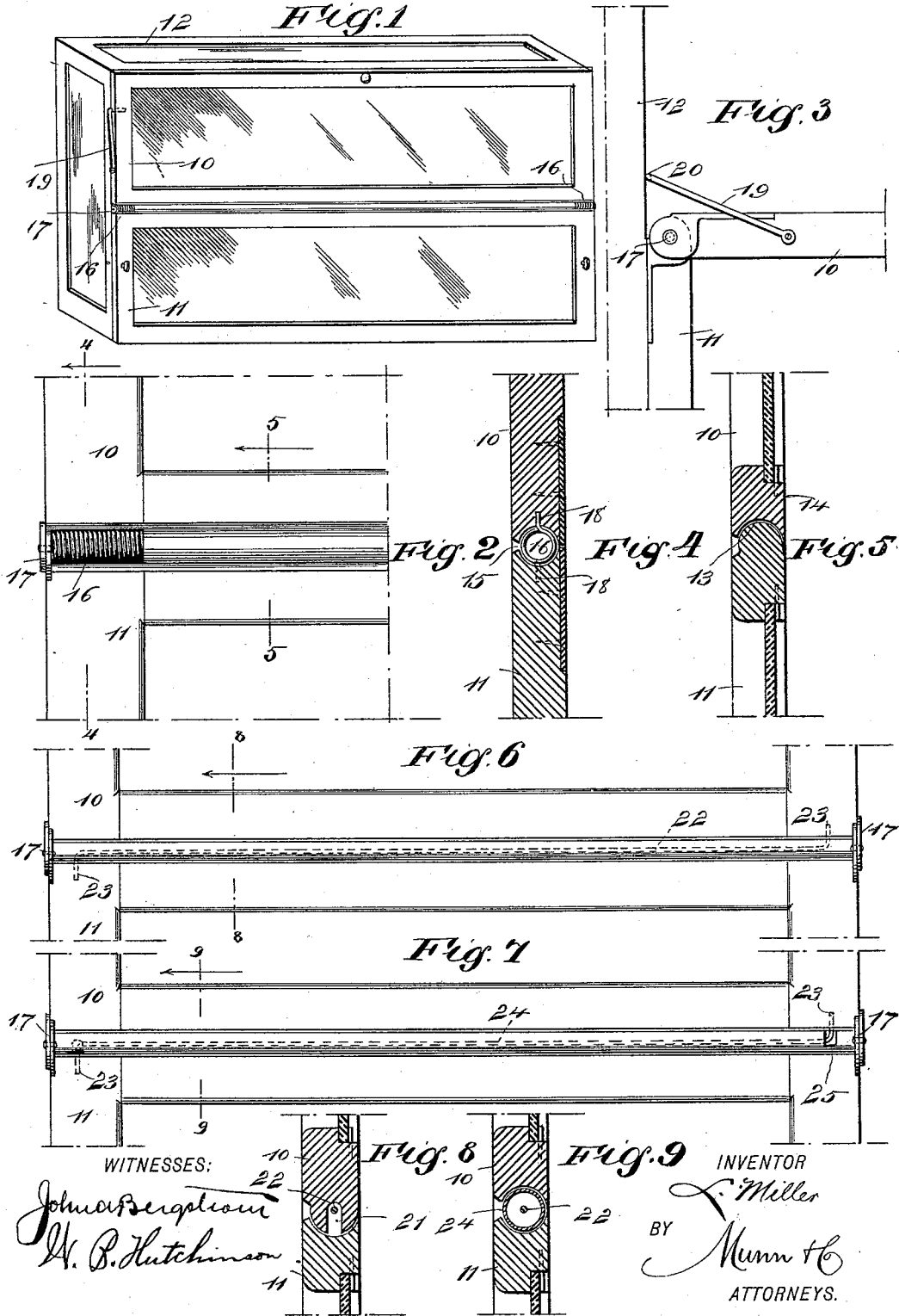

WITNESSES:
John A. Bergstrom
H. P. Hutchinson

INVENTOR
L. Miller
 BY *Munn & Co.*
 ATTORNEYS.

UNITED STATES PATENT OFFICE.

LYMAN MILLER, OF LEXINGTON, KENTUCKY.

BOX-TOP.

SPECIFICATION forming part of Letters Patent No. 525,917, dated September 11, 1894.

Application filed May 16, 1894. Serial No. 511,439. (No model.)

To all whom it may concern:

Be it known that I, LYMAN MILLER, of Lexington, in the county of Fayette and State of Kentucky, have invented a new and Improved
5 Box or Case Top, of which the following is a full, clear, and exact description.

My invention relates to improvements in that class of tops which are applied to show cases, packing boxes and similar things; and
10 the object of my invention is to produce a top or side, which may be conveniently applied to ordinary dry goods boxes or cases, so that they may be piled safely one upon the other and yet have the goods in them capable
15 of easy and advantageous exhibition, which comprises a pair of swinging doors connected in such a way that a tight joint is formed between them, which has the doors closed automatically by a spring attachment, which has
20 means for holding the door, which is permitted to swing, open, and which is cheap enough to enable it to be applied to almost any box or case.

To these ends my invention consists of certain features of construction and combinations of parts, which will be hereinafter described and claimed.

Reference is to be had to the accompanying drawings forming a part of this specification,
30 in which similar figures of reference indicate corresponding parts in all the views.

Figure 1 is a perspective view of a case provided with my improved top. Fig. 2 is a broken enlarged front elevation of a portion
35 of the top, showing the hinge connection between the two parts thereof. Fig. 3 is a broken end view of the top. Fig. 4 is a cross section on the line 4—4 of Fig. 2. Fig. 5 is a cross section on the line 5—5 of Fig. 2. Fig.
40 6 is a broken plan view of a slightly modified form of the invention. Fig. 7 is a similar view of another modification of the invention. Fig. 8 is a cross section on the line 8—8 of Fig. 6; and Fig. 9 is a cross section on the
45 line 9—9 of Fig. 7.

The improved top embodying my invention may be used on either the top or side of a box and is, as a matter of fact, generally used
50 on the side. It comprises two similar parts or doors 10 and 11, which, as illustrated, form the front side of a box or case 12 which may

be of any usual form, and the lower part or door 11 is fastened in place by thumb screws but may be fastened in any convenient way, while the upper door 10 is permitted to swing
55 outward and downward but is normally closed by the springs described below. If desired the upper door may be fastened rigidly and the lower one permitted to swing.

The door has its inner rail convex, as shown
60 at 13 in Fig. 5, so as to fit snugly with the concave portion 14 of the inner rail of the door 10, but at the ends the inner edges of both rails are recessed, as shown at 15, in
65 Fig. 4, to receive the spiral springs 16, see Figs. 1 and 2, which are coiled between the two rails and have their ends fastened to opposite rails, as shown at 18 in Fig. 4, and thus
70 the tension of the springs is such that if either door is opened it will be automatically closed and will also be held tight when closed.

The two doors are connected by hinges 17 and, under ordinary circumstances, one door is fastened to the box or case, as specified,
75 and the other used to gain access thereto. On the door 10, at the ends, are pivoted legs or arms 19 which have their free ends bent inwardly, as shown at 20, these being adapted to lie in grooves in the door, as shown by dotted lines in Fig. 1, so as to permit the door to
80 close snugly, but when the door is open, the inwardly bent ends 20 rest on the edge of the case and the legs thus serve to hold the door open against the tension of its spring.

It will be readily seen that the improved
85 top or side described above may be conveniently applied to a series of cases, so that the latter may be piled one upon another and the goods in them may be seen through the glass in the doors, while the door 10 may be swung
90 open to permit the goods to be removed and, as above remarked, the door 11 may be also made to swing if desired.

In Figs. 6 and 8 I have shown a slightly modified form of the invention, in which one
95 modified rail is convex and the other concave as already described, and as shown in Fig. 8, the convex portion is longitudinally slotted, as at 21, to receive the spring rod 22 which extends longitudinally through the slot and
100 has outwardly bent ends 23, see Fig. 6, which extend in opposite directions, one being se-

cured to the door 10 and the other to the door 11, so that the spring rod acts as above described to hold the doors tightly closed.

As shown in Figs. 7 and 9, the inner ends 5 of the meeting rails are both concaved and between them is held a tube 24 extending from hinge to hinge, and the spring rod 22 extends through this tube and its bent ends 23 project outward through slots 25 in the tube 10 and are fastened to the doors, as above described.

Having thus described my invention, I claim as new and desire to secure by Letters Patent—

15 1. A top or front for cases comprising two rectangular frames placed edge to edge and each formed of connected top, bottom and end rails, and an interlocking concavo-convex joint being formed between said meeting 20 edges and the edges of these concave and convex portions being cut away at one side to permit one door to swing outwardly at right angles, the hinges connecting the ends of said meeting edges and lying within the plane of 25 the doors to avoid projecting parts, and a spring between the said meeting edges to hold the doors closed, substantially as described.

2. A top or front for cases comprising two rectangular frames formed of connected top,

bottom and end rails, and provided on their 30 abutting edges respectively with a concave groove and a longitudinally recessed convex rib fitting therein, a spring rod extending through said rib recess and having its oppositely bent ends engaging the respective 35 frames, the edges of the two frames at one side of the groove and rib being cut away to permit either frame to swing outwardly, and hinges connecting the two frames and lying in the plane thereof, substantially as de- 40 scribed.

3. The combination with the two door frames hinged together at and having their abutting edges formed with an interlocking 45 concavo-convex joint, said edges being cut away at one side of the joint to permit either door to swing outwardly, of a stop leg pivoted to one end of the swinging frame and having its free end bent inwardly across the inner 50 face of said frame to engage the edge of the box to which said door frames are applied, a recess being provided to receive said bent end to permit the complete closure of said frame, substantially as described.

LYMAN MILLER.

Witnesses:

C. C. PATTERSON,
W. P. PARRISH.