

H. L. COE.  
AGITATOR.

APPLICATION FILED JULY 21, 1910.

1,008,010.

Patented Nov. 7, 1911.

2 SHEETS-SHEET 1.

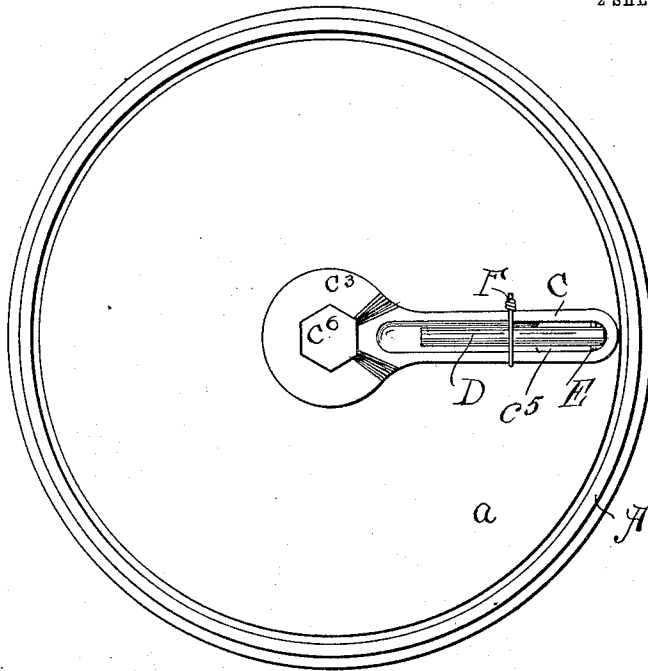

Fig. 1.

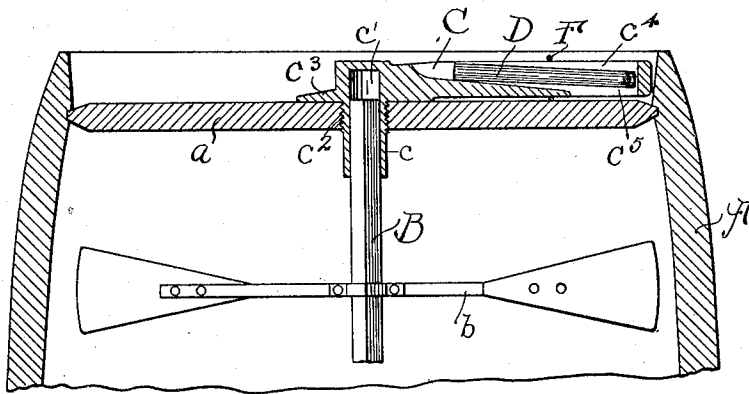

Fig. 2.

Witnesses

Elmer A. Caspell

Brennan B. West.

Inventor

Henry L. Coe

BY Albert H. Bates

ATTY.

H. L. COE.  
AGITATOR.

APPLICATION FILED JULY 21, 1910.

1,008,010.

Patented Nov. 7, 1911.  
2 SHEETS-SHEET 2.

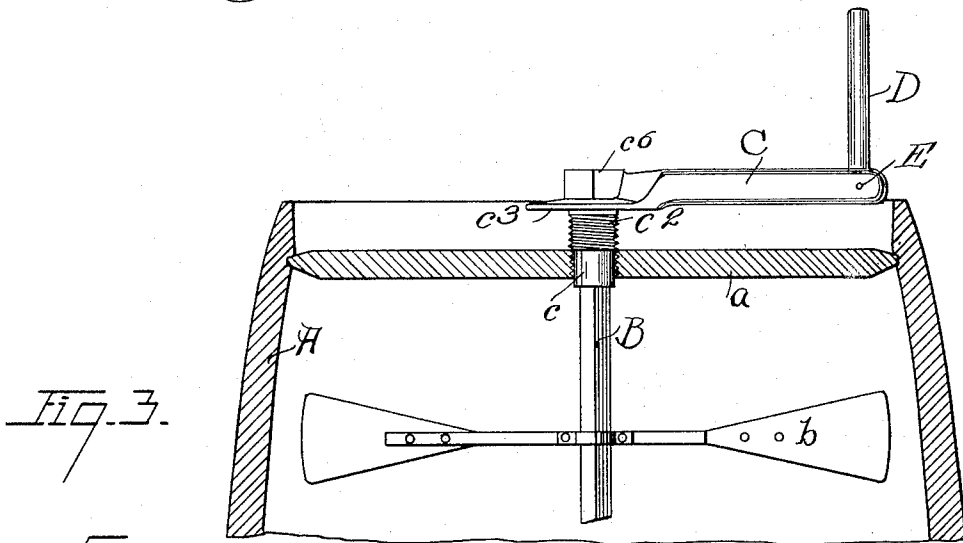
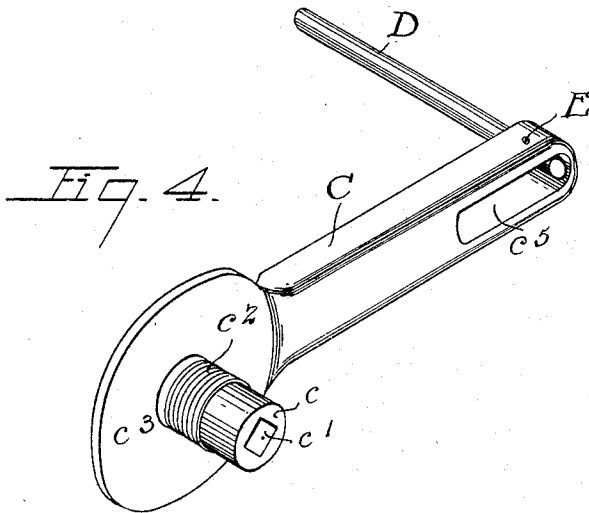

Witnesses

Elmer A. Caspell

Perman West.

Inventor

Henry L. Coe  
By Albert H. Bates  
Att'y.

# UNITED STATES PATENT OFFICE.

HENRY L. COE, OF WARREN, OHIO, ASSIGNOR TO THE WARREN PAINT COMPANY, OF WARREN, OHIO, A CORPORATION OF OHIO.

## AGITATOR.

1,008,010.

Specification of Letters Patent.

Patented Nov. 7, 1911.

Application filed July 21, 1910. Serial No. 573,022.

*To all whom it may concern:*

Be it known that I, HENRY L. COE, a citizen of the United States, residing at Warren, in the county of Trumbull and State of Ohio, have invented a certain new and useful Improvement in Agitators, of which the following is a full, clear, and exact description, reference being had to the accompanying drawings.

The object of this invention is to provide a very simple and efficient device for agitating paint or other materials in barrels.

My agitator is adapted to be applied to an ordinary barrel and includes means within the barrel for stirring or agitating the contents, and a suitable crank mechanism above the barrel head for rotating the stirrer. The crank mechanism is adapted to lie snugly against the head of the barrel and out of the way, when not in use, while it is ready for use whenever desired. For this purpose it is provided with an inwardly extending tubular crank-shaft which engages the shaft of the stirrer and has external screw threads screwing into the barrel head. Accordingly, these threads may hold the crank member snugly against the head of the barrel, closing the opening which the stirrer shaft occupies, while rotations of the crank screw its tubular shaft out of the barrel head, and thereafter it may rotate freely, operating the stirrer as long as desired.

The drawings clearly illustrate my invention.

Figure 1 is a plan of a barrel to which it is applied; Fig. 2 is a vertical section of the upper portion of the barrel, showing the crank in its idle position; Fig. 3 is a similar view showing the crank in the position it occupies in giving continuous rotations to the agitator; and Fig. 4 is a perspective of the crank itself.

As shown in the drawing, A represents any suitable barrel and *a* the head therefor. Within this barrel is an agitator having an upright shaft B and any suitable projections or wings carried thereby, as indicated conventionally at *b*. The particular form of the stirrer is immaterial. In ordinary practice, owing to the tendency of the paint to settle at the bottom of the barrel, the mechanism is designed particularly to operate with most efficiency near the bottom portion of the barrel, but it is con-

sidered sufficient to show one stirrer blade, as illustrated near the top of the barrel, which is to be taken as an example of any internal construction. The agitator shaft B is made non-circular, at least adjacent to its upper end, whereby it may be engaged and driven at such upper end. This shaft occupies an enlarged central hole in the barrel head, the shaft terminating, preferably in about the plane of the top of the head.

The crank, wherein the novel features of this invention reside, consists of the body C and a handle D. The body, which may be a single casting, has a projecting hub or sleeve *c*, which is provided with a square or other non-circular bore *c'*. This hub is adapted to extend through the center opening in the barrel head *a* and surround and embrace the shaft B. On its exterior, the hub *c* has threads *c<sup>2</sup>* which screw into the barrel head. By this means, the crank body, by being rotated, may be turned down tightly against the head. The crank body has a flaring disk-like portion *c<sup>3</sup>* around the hub, which comes down snugly against the upper face of the head when the crank is in its idle position, thereby preventing any leakage about the hub. The handle D is pivoted by a pin E in a recess *c<sup>4</sup>* in the crank body. This recess is of sufficient size to receive the handle when it is turned down in the position shown in Fig. 2, and the handle may be securely held in this position for shipping by a wire F, for example, surrounding the body and handle. This recess *c<sup>4</sup>* has preferably an open bottom at *c<sup>5</sup>*, preventing the accumulation of dirt in the recess. The bore *c'* extends not only through the hub *c*, but up into the body of the crank, so as to allow considerable leeway in the position which the upper end of the shaft B may occupy, thus providing for barrels differing somewhat in height. The portion of the bore *c'* which extends into the body above the hub *c* is inclosed by a suitable portion of the body, which may conveniently be formed angular, like a nut, as shown at *c<sup>6</sup>*. This not only gives a neat appearance, but furnishes means for attaching a wrench, should it ever be needed. The threads *c<sup>2</sup>* on the hub *c* are preferably left hand threads, the result being that a right hand rotation of the crank (which is the natural way for operating the agi-

tator) first screws the hub out of the barrel head, as shown in Fig. 3; and then, the continued right hand rotation serves to operate the agitator, as desired, the thread riding idly above the barrel head. When the agitating operation is completed, an ordinary left hand rotation of the crank screws it back into home position, as shown in Fig. 2.

10 Having thus described my invention, what I claim is:—

1. An agitator for barrel contents comprising stirring means within the barrel, and a crank on the outer side of the barrel head having a hub extending through an opening in the barrel head and engaging the stirring means, said hub having an external thread screwing into the barrel head, whereby rotation in the proper direction makes a snug engagement of the crank against the top of the head.

2. An agitator for barrel contents comprising stirring means within the barrel, a driving member on the outer side of the barrel head having a hub extending through an opening in the barrel head and engaging the stirring means, said hub having a thread adapted to screw into the barrel head and having a plain portion below the thread adapted to freely occupy the opening in the head when the thread is screwed out of it.

3. An agitator for barrel contents comprising mechanism within the barrel having a shaft occupying an opening in the barrel head, a crank having a hub occupying such opening, the hub and shaft being slidable with reference to each other but having a driving engagement, and a thread on the exterior of the hub.

4. An agitator for barrel contents comprising mechanism within the barrel having a shaft occupying an opening in a barrel head, a crank having a hub occupying such opening and embracing the shaft, the hub and shaft being slidable with reference to each other but having a driving engagement, threads on the exterior of the hub adapted to engage the barrel head, the body of the crank being provided with a disk-like extension adapted to fit snugly against the top of the head when the threads have been sufficiently turned into the opening in the head.

5. In a device of the character specified,

the combination, with a barrel and agitating mechanism, of a crank having an externally threaded hub adapted to have a driving engagement with the agitating mechanism, the threads of said hub being adapted to have an engagement with the barrel head where- by rotation may bring the crank snugly against the barrel head.

6. In a device of the character specified, the combination with a barrel and agitating mechanism, of a crank having an externally threaded hub, adapted to have a driving engagement with the agitating mechanism and a disk-like extension projecting above the threads.

7. In a device of the character specified, the combination, with a barrel and agitating mechanism, of a crank having an externally threaded hub adapted to have a driving engagement with the agitating mechanism, and an angular bore within the hub, the threads of said hubs being adapted to have an engagement with the barrel head whereby rotation may bring the crank snugly against the barrel head.

8. In a device of the character specified, the combination, with a barrel and agitating mechanism, of a crank having an externally threaded hub adapted to have a driving engagement with the agitating mechanism, the body of the crank having an elongated recess, the crank handle being pivoted to fold within the recess, and a disk extension on the crank surrounding the hub and adapted to be brought into snug engagement with the upper surface of the head by the rotation of the crank.

9. In a device of the character specified, the combination with a barrel and agitating mechanism, of a crank having an externally threaded hub, adapted to have a driving engagement with the agitating mechanism the body of the crank having an elongated recess, and the crank handle being pivoted to fold within the recess, the recess having an opening on its under side whereby it is self-cleaning.

In testimony whereof, I hereunto affix my signature in the presence of two witnesses.

HENRY L. COE.

Witnesses:

C. F. CLAPP,  
MYRTA M. KEELER.