

W. C. ROBBY & W. N. RUMELY.
PNEUMATIC STRAW STACKER.

APPLICATION FILED JUNE 21, 1902.

NO MODEL.

2 SHEETS—SHEET 1.

Fig. 1.

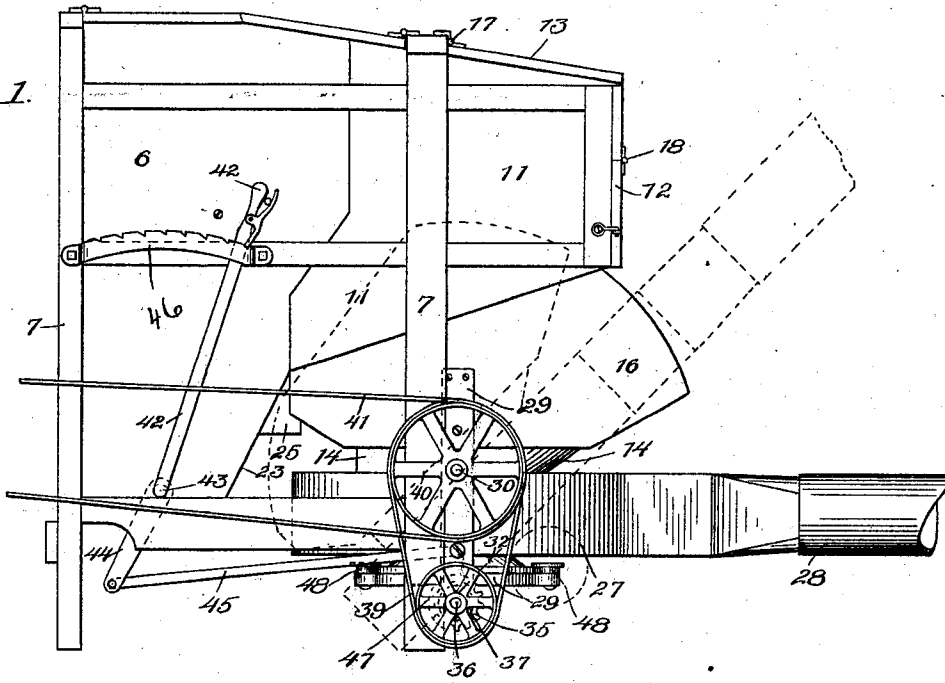
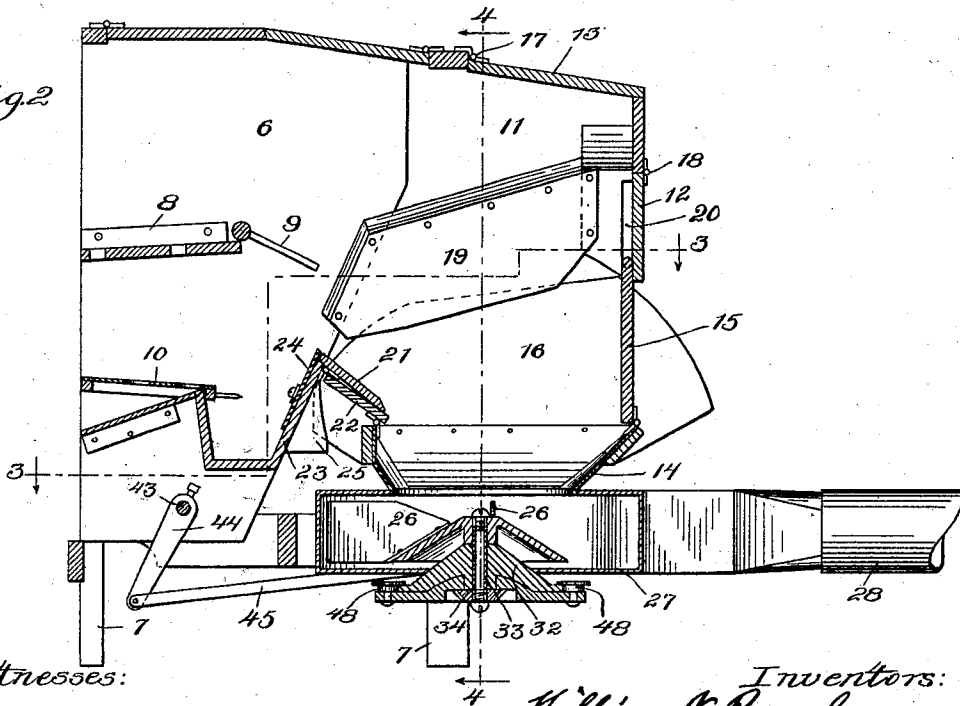

Fig. 2.



Witnesses:

Wm. Guger
A. M. Hunday

Inventors:

William N. Rumely
William C. Robby
By *Hunday, Darts & Adams*
Attorneys

W. C. ROBBY & W. N. RUMELY.
PNEUMATIC STRAW STACKER.

APPLICATION FILED JUNE 21, 1902.

NO MODEL.

2 SHEETS—SHEET 2.

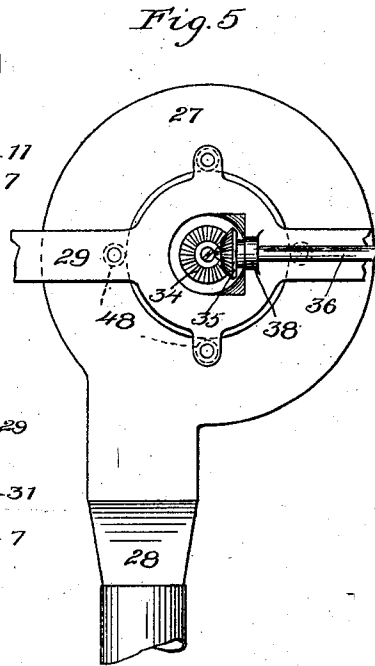
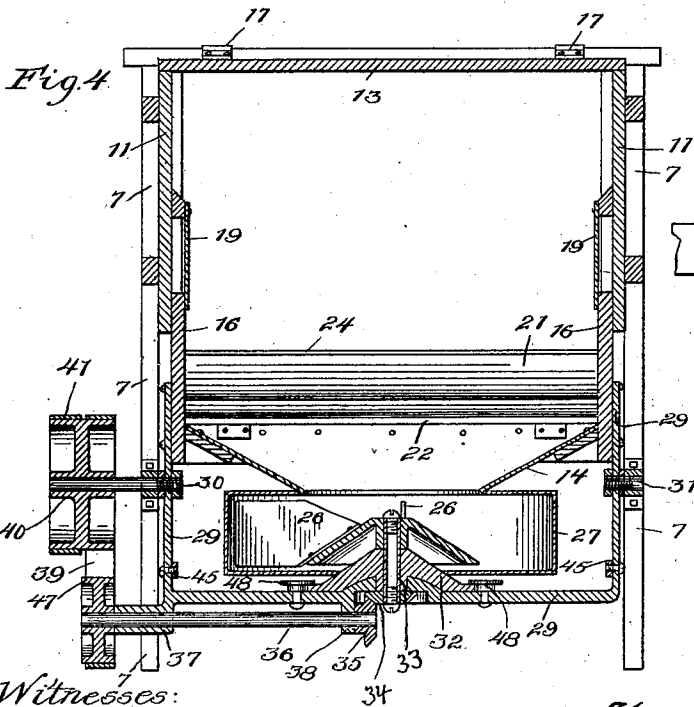
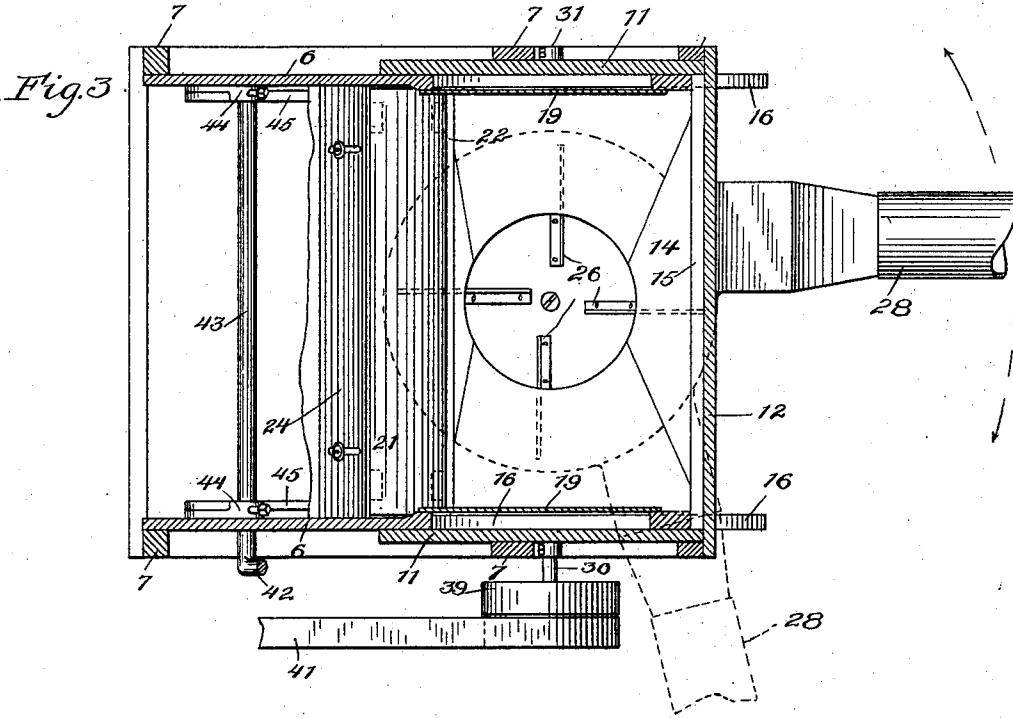

Witnesses:
Wm. Geiger
J. W. Huxley

Inventors:
William N. Rumely
William C. Robby
 By *Munday, Ward & Adams* Attorneys

UNITED STATES PATENT OFFICE.

WILLIAM C. ROBBY AND WILLIAM N. RUMELY, OF LAPORTE, INDIANA,
ASSIGNORS, BY DIRECT AND MESNE ASSIGNMENTS, TO THE INDIANA
MANUFACTURING COMPANY, OF INDIANAPOLIS, INDIANA, A CORPO-
RATION OF WEST VIRGINIA.

PNEUMATIC STRAW-STACKER.

SPECIFICATION forming part of Letters Patent No. 720,486, dated February 10, 1903.

Application filed June 21, 1902. Serial No. 112,610. (No model.)

To all whom it may concern:

Be it known that we, WILLIAM C. ROBBY and WILLIAM N. RUMELY, citizens of the United States, residing in Laporte, in the county of Laporte and State of Indiana, have invented a new and useful Improvement in Pneumatic Straw-Stackers, of which the following is a specification.

This invention relates to improvements in wind-stackers. Our endeavor therein has been to simplify the apparatus and also to render it more convenient in use.

The invention consists in the novel construction of parts and devices and the novel combinations of parts and devices hereinafter described.

The details of our invention are fully shown in the accompanying drawings and described below herein.

In the drawings, Figure 1 is a side elevation of a thresher provided with our invention. Fig. 2 is a longitudinal vertical section. Figs. 3 and 4 are sections on the lines 3-3 and 4-4, respectively, of Fig. 2. Fig. 5 is a bottom plan of the fan and stacker-tube.

In said drawings, 6-6 represent portions of the thresher-casing; 7-7, the thresher-frame; 8, the shaker; 9, a straw-deflecting rack at the rear end of the shaker, and 10 the sieve.

The straw-collecting chamber consists of an upper stationary part having side walls 11, rear wall 12, and a closed top 13, and a lower part made in the form of a hopper and consisting of a hopper portion 14, a rear plate 15, and sides 16. The top 13 may be hinged, as at 17, and the rear wall may be hinged, as at 18. The hopper is adjustably supported, as hereinafter set forth, and to permit its changes in position without forming openings

between it and the stationary part of the chamber which would destroy or lessen the power which the stacker-fan exerts in the chamber the sides 16 of the hopper are extended above the bottom of the sides 11 and also to the rear wall 12 and move in the open space formed between the sides 11 and sheet-metal linings 19, as plainly shown at Figs. 2, 3, and 4. For the same purpose the plate 15

is extended above the bottom of the rear wall 12 and slides vertically in ways 20 at its ends and is hinged to the hopper proper; and still further for the purpose of preventing the leakage of outside air into the collecting-chamber I close the opening at the front of the hopper by means of two overlapping plates 21 and 22, one hinged to the hopper and the other hinged to a stationary part of the thresher—as, for instance, the inclined cross-board 23. A depending plate 24, having slots for locking-screws, is employed to adjust the inclination of the upper plate, and the free edge of the lower plate rests on inclines 25, attached to the under face of board 23. With this construction it will be seen that the continuity of the joints between the stationary and movable parts of the collecting-chamber will not be affected by the tipping adjustments permitted the movable part, the slides 16 then merely moving through the space prepared for them in the sides of the stationary part, while the plate 15 moves vertically and always in close bearing with wall 12, and the plate 21 slides on plate 22.

The stacker-fan is shown at 26, its casing at 27, and the stacker-tube at 28. The fan-casing effects a close joint with the bottom of the hopper 14, the delivery-opening in the latter being coincident with the opening in the top of the casing, so that the straw may be drawn into the fan from the hopper. Both the casing and the entire movable portion of the collecting-chamber are supported upon a U-shaped frame 29. (Best shown at Fig. 4.) The limbs of this frame extend far enough upward to permit their attachment to the sides 16, and they are pivoted upon coincident pivots 30 and 31, bolted to the adjacent uprights 7 of the machine. This manner of supporting the fan-casing and movable part of the collecting-chamber permits both to be tipped with the frame 29 whenever it is desired to vary the inclination of the stacker-tube, this being the tipping adjustment already mentioned. The fan is supported upon a block 32, secured upon the central part of frame 29, which is widened for the purpose

of giving a broad support, and the fan is actuated by a short shaft 33, passing down through the block and carrying a bevel-gear 34 at its lower end. The gear 34 meshes with a pinion 35 on a shaft 36, revolving in bearings 37 and 38, attached to frame 29, and said shaft carries a pulley 47, driven by belt 39 from pulley 40, which is in turn driven by belt 41 from any convenient source of power. Pulley 40 may be supported on pivot 30, if desired. This construction of fan-driving mechanism is unaffected by the changes in position of the fan and its casing occurring in the tipping adjustments while the fan is in operation. The adjustments are effected by means of a hand-lever 42 on cross-shaft 43, carrying crank-arms 44, connected to the lower portions of the limbs of frame 29 by connecting-rods 45. The lever has a spring-pawl engaging a curved notched bar 46, so that it can be locked in any one of a number of positions, and thus retain the adjustment as long as desired. The fan-casing is attached to the sloping annular surface of block 32, its bottom being cut out to fit said annular surface, and as the block turns freely around the axis 33 and acts as a turn-table the casing and stacker-tube are permitted to swivel, so that the tube can be directed to either side of the machine desired without any stoppage in the operation of the machine. The supporting-frame is provided with a series of flanged rollers 48, located as shown in Fig. 5, the flanges of the rollers setting over the edge of the block and preventing any vertical movement by it and also confining it against horizontal movement.

It will be noticed that the pivots of the frame 29 are located in the plane of the top of the fan-casing. We regard this as important, as thereby only a small amount of movement or throw is imparted in the tipping adjustments.

We claim—

1. The combination in pneumatic straw-stacking apparatus, of a straw-collecting chamber having a tipping adjustable lower portion, a fan drawing its air with the straw from said chamber and located under said lower portion and tipping therewith, and a stacker-tube projecting from the fan-casing, substantially as specified.

2. The combination in pneumatic straw-stacking apparatus, of a straw-collecting chamber having its bottom made in hopper form and adapted to tip, a fan drawing its air and the straw from the tipping-chamber bottom, a swinging frame supporting both the

chamber-bottom and the fan, and a stacker-tube supported from the fan-casing, substantially as specified.

3. The combination in pneumatic straw-stacking apparatus, of a straw-collecting chamber having a tipping adjustable lower portion, a fan under said lower portion and tipping therewith, and a stacker-tube projecting from the fan-casing, the latter being swiveled on its axis to allow changes in the direction of the tube, substantially as specified.

4. In pneumatic straw-stacking apparatus, the combination of the fan, the fan-casing and the stacker-tube, the casing having a swiveling adjustment about the fan-axis and also having a tipping adjustment, and the tube being carried by the casing, substantially as specified.

5. In pneumatic straw-stacking apparatus, a stacker-tube mounted upon a vertically-tipping and horizontally-swiveling support, whereby the direction of the blast can be changed as needed without stopping the thresher and without the employment of flexible joints in the tube, substantially as specified.

6. The combination with the tipping straw-collecting hopper and the fan drawing the straw from the hopper, of a U-shaped pivoted frame supporting both the hopper and the fan, and means for locking the frame in its adjusted position, substantially as specified.

7. The straw-collecting chamber having an adjustable tipping lower portion, and means for preserving the continuity of the joints between the stationary and adjustable parts of the chamber notwithstanding the changes in position of the adjustable portion, substantially as specified.

8. The straw-collecting chamber having an adjustable tipping lower portion, and means for preserving the continuity of the joints between the stationary and adjustable parts of the chamber notwithstanding the changes in position of the adjustable portion, consisting of overlapping plates or devices, substantially as specified.

9. In a pneumatic stacker, a tipping fan and a supporting-frame therefor, the latter being pivoted on a line with the top of the fan-casing, substantially as specified.

WILLIAM C. ROBBY.
WILLIAM N. RUMELY.

Witnesses:

S. J. PATTERSON,
JOS. M. EBERHARDT.