



- (51) International Patent Classification:
C07C 2/86 (2006.01) C07C 11/173 (2006.01)
C07C 11/06 (2006.01)
- (21) International Application Number:
PCT/US20 12/071102
- (22) International Filing Date:
21 December 2012 (21.12.2012)
- (25) Filing Language: English
- (26) Publication Language: English
- (30) Priority Data:
61/579,777 23 December 2011 (23.12.2011) US
- (71) Applicant: DOW GLOBAL TECHNOLOGIES, LLC
[US/US]; 2040 Dow Center, Midland, Michigan 48674 (US).
- (72) Inventors: TIRTOWIDJOJO, Max Markus; 110 Rosewood, Lake Jackson, Texas 77566 (US). STEARS, Brien; 5227 Pilgrim Oaks Lane, League City, Texas 77573 (US). KRUPER, William J.; 230 Barden Road, Sanford, Michigan 48657 (US). HIRSEKORN, Kurt Frederick; 5631 Bloomfield Court, Midland, Michigan 48642 (US). CHAKRABORTY, Debashis; 109 Northwood Drive, Lake Jackson, Texas 77566 (US).
- (74) Agent: JORDAHL, Kimberly S.; PO Box 517, Willernie, Minnesota 55090 (US).

- (81) Designated States (unless otherwise indicated, for every kind of national protection available): AE, AG, AL, AM, AO, AT, AU, AZ, BA, BB, BG, BH, BN, BR, BW, BY, BZ, CA, CH, CL, CN, CO, CR, CU, CZ, DE, DK, DM, DO, DZ, EC, EE, EG, ES, FI, GB, GD, GE, GH, GM, GT, HN, HR, HU, ID, IL, IN, IS, JP, KE, KG, KM, KN, KP, KR, KZ, LA, LC, LK, LR, LS, LT, LU, LY, MA, MD, ME, MG, MK, MN, MW, MX, MY, MZ, NA, NG, NI, NO, NZ, OM, PA, PE, PG, PH, PL, PT, QA, RO, RS, RU, RW, SC, SD, SE, SG, SK, SL, SM, ST, SV, SY, TH, TJ, TM, TN, TR, TT, TZ, UA, UG, US, UZ, VC, VN, ZA, ZM, ZW.
- (84) Designated States (unless otherwise indicated, for every kind of regional protection available): ARIPO (BW, GH, GM, KE, LR, LS, MW, MZ, NA, RW, SD, SL, SZ, TZ, UG, ZM, ZW), Eurasian (AM, AZ, BY, KG, KZ, RU, TJ, TM), European (AL, AT, BE, BG, CH, CY, CZ, DE, DK, EE, ES, FI, FR, GB, GR, HR, HU, IE, IS, IT, LT, LU, LV, MC, MK, MT, NL, NO, PL, PT, RO, RS, SE, SI, SK, SM, TR), OAPI (BF, BJ, CF, CG, CI, CM, GA, GN, GQ, GW, ML, MR, NE, SN, TD, TG).

Published:
— with international search report (Art. 21(3))

(54) Title: PROCESS FOR THE PRODUCTION OF ALKENES AND/OR AROMATIC COMPOUNDS

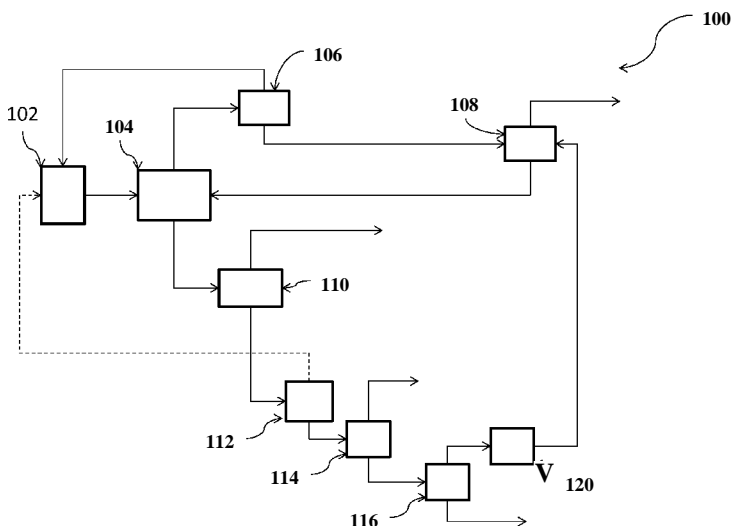

FIGURE 1

(57) Abstract: Processes for the production of alkenes are provided. The processes make use of methane as a low cost starting material.



PROCESS FOR THE PRODUCTION OF ALKENES AND/OR AROMATIC
COMPOUNDS

FIELD

[0001] The present invention relates to the use of methane in the production of alkenes and/or aromatic compounds.

BACKGROUND

[0002] The economic viability of any manufacturing business relies, at least to some extent, on the ability to convert low cost starting materials to higher value products. Particularly in the large scale manufacture of commodity chemicals, a difference in material cost of under a dollar per unit, or even pennies per unit, can determine whether a process is economically viable or not. Maximization of the difference between material cost and product value can also render a costly process more economically attractive.

[0003] One example of a class of such processes includes processes for the production of higher alkanes and/or alkenes, e.g., those including from three to ten (C₃-C₁₀) carbon atoms. Propene, for example, can be used in the production of high performance garments for use by athletes and the military, and is also used in the production of other functional monomers, such as propylene oxide, acrylic acid, allyl chloride, and epichlorohydrin. And, alkanes and alkenes having from three to ten carbon atoms can be used in the production of gasoline.

[0004] Many conventional processes for the manufacture of these alkanes and alkenes comprising from three to ten carbon atoms (C₃-C₁₀), utilize propane as a starting material. Propane may typically cost between twenty and sixty cents per pound. And, processes for the conversion of propane to C₃-C₁₀ alkanes and alkenes are generally conducted at extreme temperatures, e.g., of 600°C or greater, and typically require the use of a catalyst. Such process conditions are not only expensive in utility and material cost and capital equipment, but can also generate safety concerns.

[0005] Furthermore, gas phase processes conducted at such high temperatures may result in large amounts of reactant, byproduct and/or product decomposition relative to lower temperature processes. Decomposition, in turn, can take the form of carbonaceous deposits

forming within the process equipment, which can shorten the time required between reactor cleaning and thereby increase reactor downtime. Catalysts used in high temperature processes may also experience a shortened active lifetime when operated at extreme temperatures, as compared to the lifetimes they may exhibit at lower operating temperatures. While catalyst regeneration is possible, it requires additional capital and operating cost.

[0006] Processes for the production of C₃-C₁₀ alkanes and alkenes would thus desirably be provided that make use of cost effective starting materials. Such processes would be further advantageous if the materials utilized were capable of utilization at operating conditions less intense than conventional materials and/or that require lesser capital expenditure to use. Elimination of the need to employ catalysts would not only provide further material savings, but also capital cost savings via elimination of the need to purchase catalyst regeneration equipment.

BRIEF DESCRIPTION

[0007] The present invention provides such processes. More particularly, the present processes utilize a feedstream comprising methane, which is one third the cost of propane, as a starting material. Furthermore, the process does not require the use of solid/ heterogeneous catalyst and so capital and operating cost savings are provided. Finally, methane may be converted to alkenes and/or aromatic compounds using lower intensity process conditions than propane, and so, utility and capital cost savings are provided.

[0008] In one aspect, there is provided a process for the production of one or more alkenes and/or aromatic compounds, using a feedstream comprising methane. The feedstream is reacted with at least one monochloroalkene, which in some embodiments may be vinyl chloride. The reaction optionally takes place in the presence of a catalyst, such as a free radical initiator. The process is carried out at low process intensity conditions, e.g., temperatures of less than 700°C, or less than 600°C, and pressures of less than 4000 psig, or 3000 psig, or 2000 psig, or 1000 psig, or 500 psig, or 400 psig (2757.9 kilopascals gauge (kPa gauge)), or less than 300 psig (2068.4 kPa gauge), wherein "psig" is used as an abbreviation herein for pounds per square inch gauge. The process may be used to produce C₃-C₁₀ alkenes and/or C₅-C₁₀ aromatics. In some embodiments, the process may be used to

produce C₃-C₆ alkenes, and in some of these, may be used to produce propenes, butenes and/or pentenes. The processes may also include the step of converting any alkenes produced, to alkanes, if desired.

[0009] Some embodiments of the process may result in the formation of the byproduct HC1, which can then be used to generate the vinyl chloride utilized by the process, by reacting the same with acetylene. The acetylene, in turn, can be generated by partially oxidizing the methane feedstream.

[0010] DESCRIPTION OF THE FIGURES

[0011] FIG. 1 shows a schematic representation of one embodiment of the process;

[0012] FIG. 2 is a graphical depiction of conversion of methane, vinyl chloride and carbon tetrachloride to monochloropropane, 1,4-pentadiene, and propene as a function of temperature at 260 psig (1792.6 kPa gauge) and a 3.6 molar ratio of methane to vinyl chloride;

[0013] FIG. 3 is a graphical depiction of the selectivity of the reaction of methane, vinyl chloride and carbon tetrachloride to monochloropropane, 1,4-pentadiene, and propene as a function of temperature at 260 psig (1792.6 kPa gauge) and a 3.6 molar ratio of methane to vinyl chloride;

[0014] FIG. 4 is a graphical depiction of conversion of methane, vinyl chloride and carbon tetrachloride to monochloropropane, 1,4-pentadiene, and propene as a function of residence time at 260 psig (1792.6 kPa gauge) and a 3.6 molar ratio of methane to vinyl chloride;

[0015] FIG. 5 is a graphical depiction of the selectivity of the reaction of methane, vinyl chloride and carbon tetrachloride to monochloropropane, 1,4-pentadiene, and propene as a function of percent vinyl chloride conversion at 260 psig (1792.6 kPa gauge) and a 3.6 molar ratio of methane to vinyl chloride;

[0016] FIG. 6 is a graphical depiction of the conversion of methane, vinyl chloride and carbon tetrachloride to monochloropropane, 1,4-pentadiene, and propene as a function of reactor pressure at 420°C and a 3.6 molar ratio of methane to vinyl chloride;

[0017] FIG. 7 is a graphical depiction of the selectivity of the reaction of methane, vinyl chloride and carbon tetrachloride to monochloropropane, 1,4-pentadiene, and propene as a function of reactor pressure at 420°C and a 3.6 molar ratio of methane to vinyl chloride;

[0018] FIG. 8 is a is a graphical depiction of the conversion of methane, vinyl chloride and carbon tetrachloride as a function of the molar ratio of methane to vinyl chloride at 400°C and 450 psig (3 102.6 kPa gauge); and

[0019] FIG. 9 is a graphical depiction of the selectivity of the reaction of methane, vinyl chloride and carbon tetrachloride to monochloropropane, 1,4-pentadiene, and propene as a function of the molar ratio of methane to vinyl chloride at 400°C and 450 psig (3102.6 kPa gauge).

DETAILED DESCRIPTION

[0020] The present specification provides certain definitions and methods to better define the present invention and to guide those of ordinary skill in the art in the practice of the present invention. Provision, or lack of the provision, of a definition for a particular term or phrase is not meant to imply any particular importance, or lack thereof. Rather, and unless otherwise noted, terms are to be understood according to conventional usage by those of ordinary skill in the relevant art.

[0021] The terms "first", "second", and the like, as used herein do not denote any order, quantity, or importance, but rather are used to distinguish one element from another. Also, the terms "a" and "an" do not denote a limitation of quantity, but rather denote the presence of at least one of the referenced item, and the terms "front", "back", "bottom", and/or "top", unless otherwise noted, are merely used for convenience of description, and are not limited to any one position or spatial orientation.

[0022] As used herein, percent (%) conversion is meant to indicate change in molar or mass flow of reactant in a reactor in ratio to the incoming flow, while percent (%) selectivity means the change in molar flow rate of product in a reactor in ratio to the change of molar flow rate of a reactant.

[0023] Reference throughout the specification to "one embodiment" or "an embodiment" means that a particular feature, structure, or characteristic described in connection with an embodiment is included in at least one embodiment. Thus, the appearance of the phrases "in one embodiment" or "in an embodiment" in various places throughout the specification is not necessarily referring to the same embodiment. Further, the particular features, structures or characteristics may be combined in any suitable manner in one or more embodiments.

[0024] "VCM" may be used herein as an abbreviation for vinyl chloride, "M4" and "CC14" may be used as abbreviations for carbon tetrachloride, "1,4-Ptd=" may be used as an abbreviation for 1,4-pentadiene. "psig" is used as an abbreviation herein for pounds per square inch gauge, and "kPa" is used as an abbreviation for kilopascals. "CX", wherein X is an integer, is used herein to indicate a molecule having X carbon atoms. An "aromatic" compound, is meant to indicate a compound comprising a conjugated ring of unsaturated bonds, lone pairs of electrons, or empty orbitals, such that the compound exhibits a stabilization stronger than would be expected by the stabilization of conjugation alone.

[0025] The present invention provides processes for the production of alkenes and/or aromatics, and in some embodiments, alkenes having from 3 to 10 carbon atoms, or from 3 to 6 carbon atoms and/or aromatic compounds having from 5 to 10 carbon atoms, using a feedstream comprising methane. Methane is a lower cost starting material than, e.g., propane, and furthermore, may be available in some locations via pipeline, thereby avoiding shipping costs. Furthermore, with the proposed process methane may react at lower intensity process conditions than of conventional process using other alkane starting materials. For example, whereas propane often is processed at temperatures of 700°C or higher, the present processes are conducted at temperatures of less than 700°C, or less than 600°C, or even less than 500°C.

[0026] The methane feedstream is desirably reacted with a monochloroalkene having the formula $R_1-CCl=CH-R_2$ where R_1 and R_2 may each independently be hydrogen or an alkyl group having from 1 to 4 carbon atoms. Suitable monochloroalkenes thus include, e.g., vinyl chloride. As mentioned above, the reaction may advantageously take place at temperatures of less than 700°C, less than 600°C or even less than 500°C. Furthermore, elevated pressures are not required, and in fact, at some level, increased pressure may have little, or no, impact

on the conversion of methane and vinyl chloride. And so, pressures of less than 400 psig, or less than 300 psig may be used, if any pressure above ambient is to be used.

[0027] The reaction between methane and vinyl chloride will proceed under the stated reaction conditions, but may benefit from being conducted in the presence of a catalyst. In embodiments wherein such advantages are desired, a catalyst may be used. Any free radical catalyst or initiator is believed to be suitable, and those of ordinary skill in the art are aware of many. Any of these may be utilized and examples include, but are not limited to, compounds comprising one or more azo-groups (R-N=N-R') such as azobisisobutyronitrile (AIBN) or 1,1'-azobis(cyclohexanecarbonitrile) (ABCN), organic peroxides such as di-tert-butyl peroxide, benzoyl peroxide, methyl ethyl ketone peroxide, and acetone peroxide. Since the reaction of methane and vinyl chloride is a chain reaction involving chlorine radicals, chlorinated compounds, such as carbon tetrachloride and hexachloroacetone may also be utilized, and in fact, may be preferred. UV or visible light may also be utilized to catalyze chlorinations that proceed via a free radical mechanism. Combinations of any number of these may also be utilized.

[0028] The amount of any free radical initiator will depend upon the particular catalyst chosen as well as the other reaction conditions. Generally speaking, in those embodiments of the invention wherein the utilization of a catalyst is desired, enough of the catalyst should be utilized to provide some improvement to reaction process conditions (e.g., a reduction in required temperature) or realized products, but yet not be more than will provide any additional benefit, if only for reasons of economic practicality.

[0029] For purposes of illustration only, useful concentrations of each free radical initiator will range from 0.001% to 30% by weight each with respect to vinyl chloride or from 0.01% to 20%, or from 0.1% to 10 wt%, or from 1% to 6 wt%, inclusive of endpoint, intermediate values, and all subranges therebetween. Any endpoint and/or intermediate values are also independently combinable.

[0030] The methane and vinyl chloride will react under the described conditions at any molar ratio, and any molar ratio of the two reactants may thus be utilized. Relatively equal molar ratios may be utilized, and a preponderance of one reactant relative to the other is also

suitable. And so, in some embodiments, the ratio of methane to vinyl chloride is desirably 1:1, while in others the ratio may desirably be 1:2, or 1:3, or 1:4, or 1:5, or, in other embodiments, may be 2:1, or 3:1, or 4:1, or 5:1. Since vinyl chloride is the limiting reactant in the reaction, excess methane may be present to improve the selectivity to propene and in some embodiments, this may be preferred.

[0031] The reaction between methane and vinyl chloride proceeds quickly, and conversion of vinyl chloride, can be seen at the above described reaction conditions in residence times of less than 8 hours, or less than 6 hours, or less than 4 hours, or less than 2 hours, or less than 1 hour, or less than 30 minutes, or less than 15 minutes, or less than 10 minutes, or 5 minutes, or less than 200 seconds, or less than 100 seconds, or less than 50 seconds, or even less than 40 seconds.

[0032] When conducted at temperatures of less 700°C, less than 600°C or even less than 500°C, pressures of less than 4000 psig, or 3000 psig, or 2000 psig, or 1000 psig, or 500 psig, or 400 psig (2757.9 kilopascals gauge (kPa gauge)), or less than 300 psig (2068.4 kPa gauge), and either with or without a free radical catalyst, the reaction of methane with vinyl chloride is expected to produce propene, monochloropropene, 1,4-pentadiene and higher hydrocarbons and aromatics. The selectivity to any particular product may be adjusted by controlling the conversion of vinyl chloride, and in some embodiments, the same is contemplated.

[0033] For example, when the production of a greater proportion of pentadienes and aromatic hydrocarbons is desired, the conversion of vinyl chloride is maximized, e.g., to 40% or greater. On the other hand, if lower alkenes, e.g., propenes and monochloropropanes, are desirably produced in greater proportions, the conversion of vinyl chloride may desirably be limited to, e.g., less than 40%. Vinyl chloride conversion may be increased by increasing one or more of reaction temperature, reaction pressure, reactor residence time, and/or the molar ratio of methane to vinyl chloride, while vinyl chloride conversion may be decreased by decreasing one or more of these.

[0034] Particular examples of embodiments wherein the vinyl chloride conversion is maximized to increase the production of pentadienes and aromatic hydrocarbons would include processes wherein the molar ratio of methane to vinyl chloride is 3.5, 3.6, 3.7, 3.8,

3.9, 4.0, 4.1, 4.2, 4.3, 4.4, 4.5 or greater, the reaction temperature is 400°C, 440°C, 445°C, 450°C, 455°C, 460°C, 465°C, 470°C, 475°C, 480°C, 485°C, 490°C, 500°C, or greater, reaction pressure is 10, 100, 150, 250, 255, 260, 265, 270, 275, 280, 285, 290, 295, or 300 psig or greater (1723.3, 1757.8, 1792.3, 1826.7, 1861.2, 1895.7, 1930.1, 1964.6, 1999.1, 2033.5, or 2067.9 kPa gauge) and reactor residence time is 0.1, 1, 10, 11, 12, 13, 14, 15, 20, 25, 30, 45 or 60 minutes or longer, wherein each individual parameter is independently combinable with every other individual parameter and subparameter in between.

[0035] Particular examples of embodiments wherein the vinyl chloride conversion is limited to increase the production of propenes and monochloropropanes would include processes wherein the molar ratio of methane to vinyl chloride is 3.5, 3.4, 3.3, 3.2, 3.1, 3.0, 2.9, 2.8, 2.7, 2.6, 2.5, or 2.4 or lower, the reaction temperature is 440°C, 435°C, 430°C, 425°C, 420°C, 415°C, 410°C, 405°C, 400°C, 395°C, 390°C, 385°C, or lower, reaction pressure is 4000, 3000, 2000, 1000, 500, 400, 300, 250, 245, 240, 235, 230, 225, 220, 215, 210, 205, or 200 psig or lower and reactor residence time is 10, 9, 8, 7, 6, 5, 4, 3, 2, or 1 minute, or 50 seconds, or 40 seconds or less, wherein each individual parameter is independently combinable with every other individual parameter, including endpoints and intermediate values.

[0036] A schematic illustration of such a process is shown in Figure 1. As shown in Figure 1, process 100 would make use of reactor 102, quench and purification unit 104, separation units 106, 108, 110, 112, 114, and 116, and a dehydrochlorination reactor 120.

[0037] In operation, a feedstock comprising methane and vinyl chloride is fed to reactor 102 and reacted at a pressure of from 200 psig to 400 psig and a temperature of from 400°C to 500°C to produce to produce monochloropropene, pentadiene, propene, and HCl. This product stream from reactor 102 is provided to a quench and separation unit 104 where the product can be either fully or partially condensed before an overhead stream thereof is fed to separation unit 106.

[0038] Separation unit 106 is operated at conditions effective to provide HCl, unreacted methane, and some propene in an overhead stream, recycled to reactor 102, and HCl and propene in a bottom stream that is fed to separation unit 108. Separation unit 108 is operated

at conditions effective to provide anhydrous HCl in an overhead stream, and propene and heavier byproducts in a bottoms stream that is recycled to separation unit 104.

[0039] The bottom stream from separation unit 104, comprising unreacted vinyl chloride, propene, 1,4-pentadiene and monochloropropene is provided to separation unit 110. Separation unit 110 is operated at conditions effective to provide purified propene in an overhead stream, and vinyl chloride and byproducts in a bottoms stream that is fed to separation unit 112. The overhead of separation unit 112, comprising vinyl chloride, is then recycled to reactor 102, while the bottom stream from separation unit 112, comprising 1,4-pentadiene and monochloropropene, is sent to separation unit 114.

[0040] Separation unit 114 provides purified 1,4-pentadiene in an overhead stream, and monochloropropene and heavier byproducts in a bottoms stream. This bottoms stream is provided to a separation unit 116 that provides purified monochloropropene in an overhead stream and heavier byproducts in the bottom stream. The by products are appropriately disposed of, and the monochloropropene isomers are fed to dehydrochlorination reactor 120.

[0041] Dehydrochlorination reactor 120 may preferably be a gas-phase reactor operated at temperatures of from 400°C to 500°C so that at least a portion of the monochloropropene isomers are converted to propene and HCl. The product stream from dehydrochlorination reactor 120 is recycled to separation unit 108 to recover propene and HCl.

[0042] Propenes produced by the present process may typically be processed to provide further downstream products including polypropylene, allyl chloride, acrolein, acrylic acid, and propylene oxide. Since the present invention provides an improved process for the production of propene using a lower cost starting material it is contemplated that the cost savings provided will these downstream processes and/or products. Improved methods for the production of the same are thus also contemplated.

[0043] Some embodiments of the invention will now be described in detail in the following examples.

[0044] Example 1.

[0045] A 50 cc reaction tube, having an effective reaction length of 25.34 cm, is isothermally heated to a temperature of 400°C to 500°C and charged with a mixture of 3.6 molar ratio of methane to vinyl chloride monomer, with 5.7mole% carbon tetrachloride as initiator. The residence time is approximately 32 seconds at 260psig (1792.3 kPa gauge), 420°C and a flow rate of 757 SCCM. The expected conversion of the limiting reagent, vinyl chloride, is 10%, as shown in Figure 2. Figure 2 also shows that higher conversions of the reactants are expected at higher temperatures.

[0046] Figure 3 shows that at temperatures below 440°C and vinyl chloride conversions of less than 40%, selectivity to propene and monochloropropane is >50%. Here the selectivity is defined as moles of product produced per moles of VCM consumed. Conversions are increased at higher temperatures, as is selectivity to 1,4-pentadiene (14Ptd=) and other hydrocarbon aromatics. Figure 3 thus shows that reaction temperature can be used to adjust the relative production rate of propene versus pentadiene and hydrocarbon aromatic compounds.

[0047] Example 2.

[0048] A 50 cc reaction tube, having an effective reaction length of 25.34 cm, is isothermally heated to a temperature of 420°C and charged with a mixture of 3.6 molar ratio of methane to vinyl chloride monomer, with 5.7mole% carbon tetrachloride as initiator. The residence time is approximately 32 seconds to 8 minutes at 260psig (1792.3 kPa gauge), 420°C and a flow rate of 757 SCCM. The expected conversion of the limiting reagent, vinyl chloride, is higher than 40%, as shown in Figure 4.

[0049] Figure 5 shows the impact of percent vinyl chloride conversion on product selectivities. Figure 5 thus shows that residence time can be used to adjust the relative production rate of propene versus pentadiene and hydrocarbon aromatics.

[0050] Example 3.

[0051] A 50 cc reaction tube, having an effective reaction length of 25.34 cm, is isothermally heated to a temperature of 420°C and charged with a mixture of 3.6 molar ratio

of methane to vinyl chloride monomer, with 5.7mole% carbon tetrachloride as initiator. The pressure is increased from 260 psig (1792.3 kPa gauge) to 450 psig (3102.0 kPa gauge) at a residence time of 32 seconds, 420°C and a flow rate of 757 SCCM. Figure 6 shows that reactant conversions are expected to increase with reactor pressure.

[0052] Figure 7 shows that reactor pressure has little impact on product selectivity, so long as the limiting reagent conversion is maintained below 40%.

[0053] Example 4.

[0054] A 50 cc reaction tube, having an effective reaction length of 25.34 cm, is isothermally heated to a temperature of 400°C and charged with a mixture of from 1:1 to 3.6 molar ratio of methane to vinyl chloride monomer with 5.7mole% carbon tetrachloride as initiator. The residence time is approximately 32 seconds at 450psig (3102.0 kPa gauge) and a flow rate of 757 SCCM. Figure 8 shows the impact of varying carbon tetrachloride vinyl chloride molar ratio at these pressure and temperature conditions.

[0055] Figure 9 shows that the selectivity to monochloropropene and propene is up to 70% or higher at these conditions, particularly at methane to vinyl chloride molar ratios greater than two.

CLAIMS:

1. A process for the production of one or more alkenes and/or aromatic compounds, comprising reacting a feedstream comprising an alkane with at least one monochloroalkene.
2. The process of claim 1, wherein the reaction is carried out in the presence of a free radical initiator.
3. The process of claim 1 or 2, where the monochloroalkene comprises vinyl chloride.
4. The process of claim 1 or 2, wherein the alkane is methane.
5. The process of claim 2, wherein the free radical initiator comprises carbon tetrachloride, hexachloroacetone, hexachloroethane, or combinations of these.
6. The process of claim 1 or 2, wherein the process is carried out at a temperature of less than 700°C.
7. The process of claim 1 or 2, wherein the process is carried out at a pressure of less than 4000 psig (27579 kPa gauge).
8. The process of claim 1 or 2, wherein the one or more alkenes comprise from three to 10 carbon atoms and/or one or more aromatic compounds comprise from 5 to 10 carbon atoms.
9. The process of claim 8, wherein the one or more alkenes comprise propene and/or 1,4-pentadiene.
10. The process of claim 9, further comprising converting at least one of the one or more alkenes to one or more alkanes.
11. The process of claim 1 or 2, wherein at least a portion of the monochloroalkene is generated within, or upstream of, the process.
12. The process of claim 3, wherein the vinyl chloride is generated by reacting acetylene and HCl, wherein the HCl is generated by the process.

13. The process of claim 1 or 2, wherein the process produces one or more monochloroalkanes comprising from three to 10 carbon atoms.

14. The process of claim 13, wherein the monochloroalkane comprises monochloropropane.

1/9

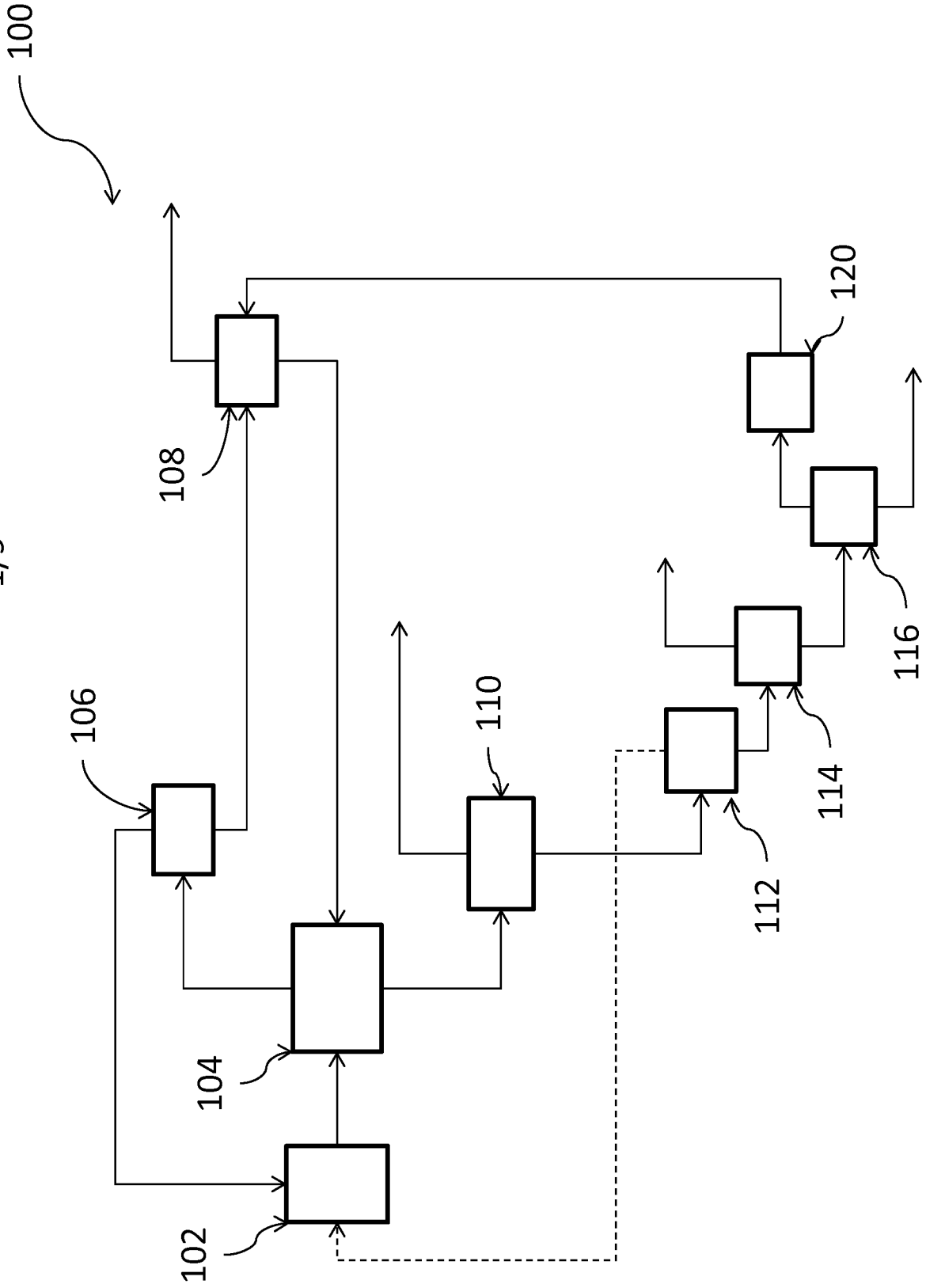

FIGURE 1

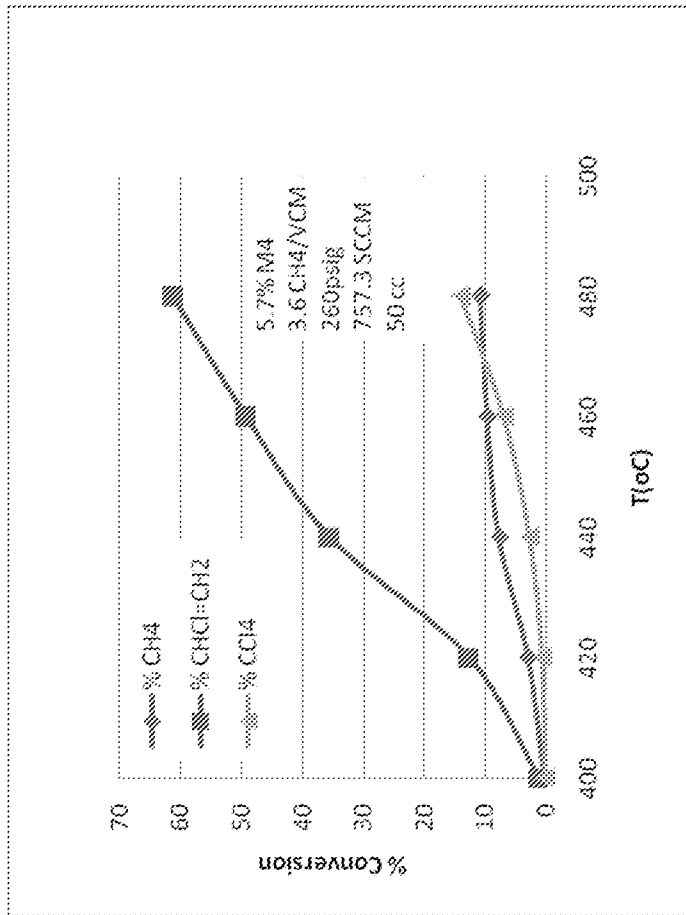

Figure 2

3/9

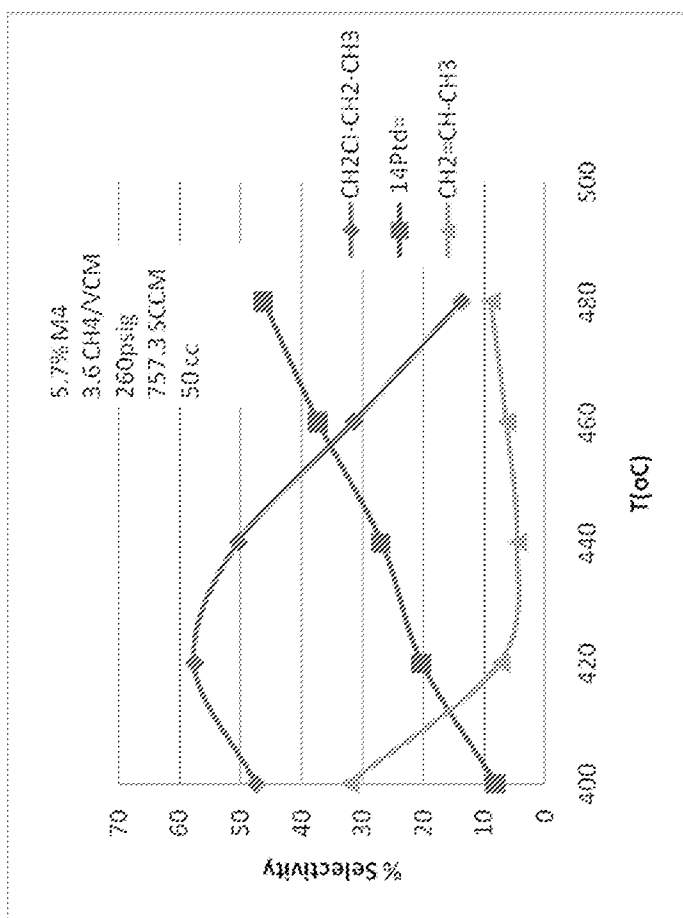

FIGURE 3

4/9

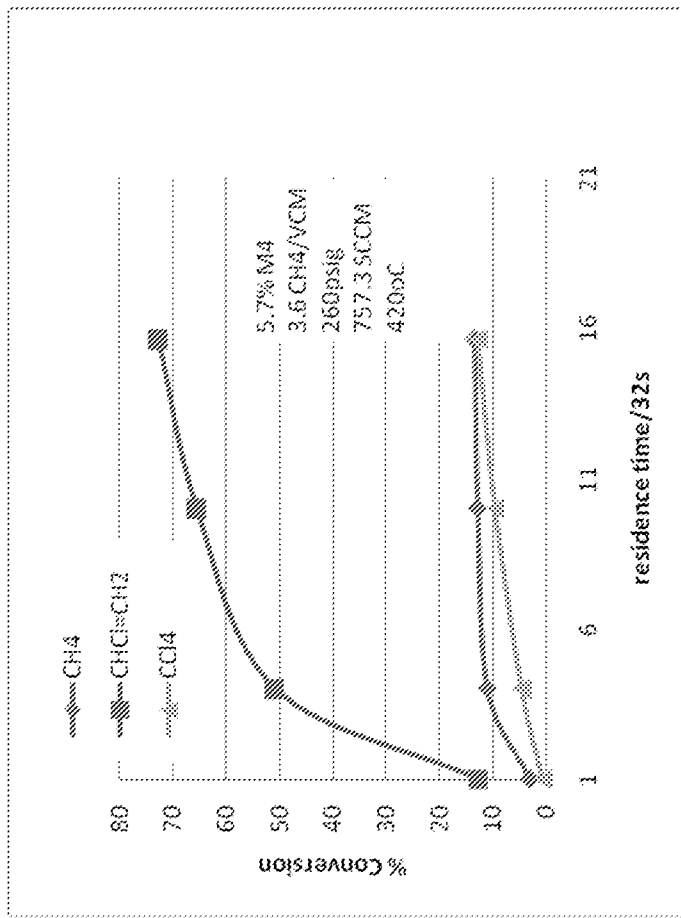

FIGURE 4

5/9

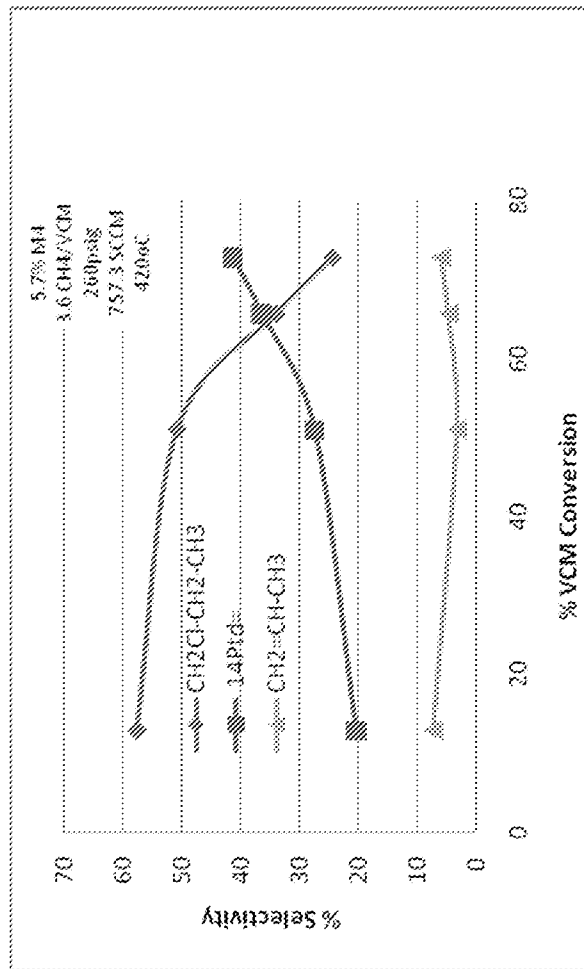

FIGURE 5

6/9

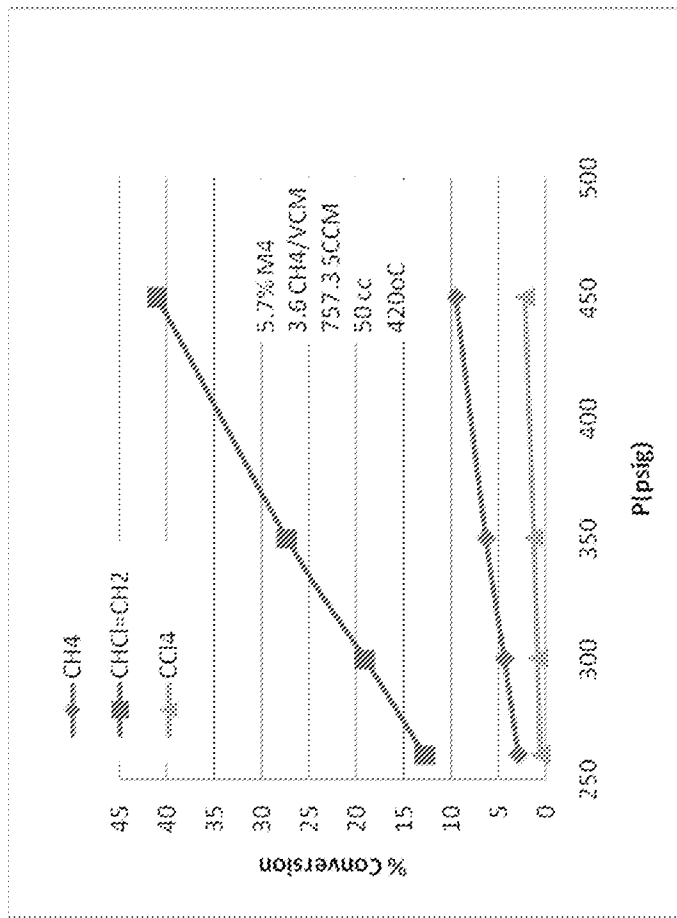

FIGURE 6

7/9

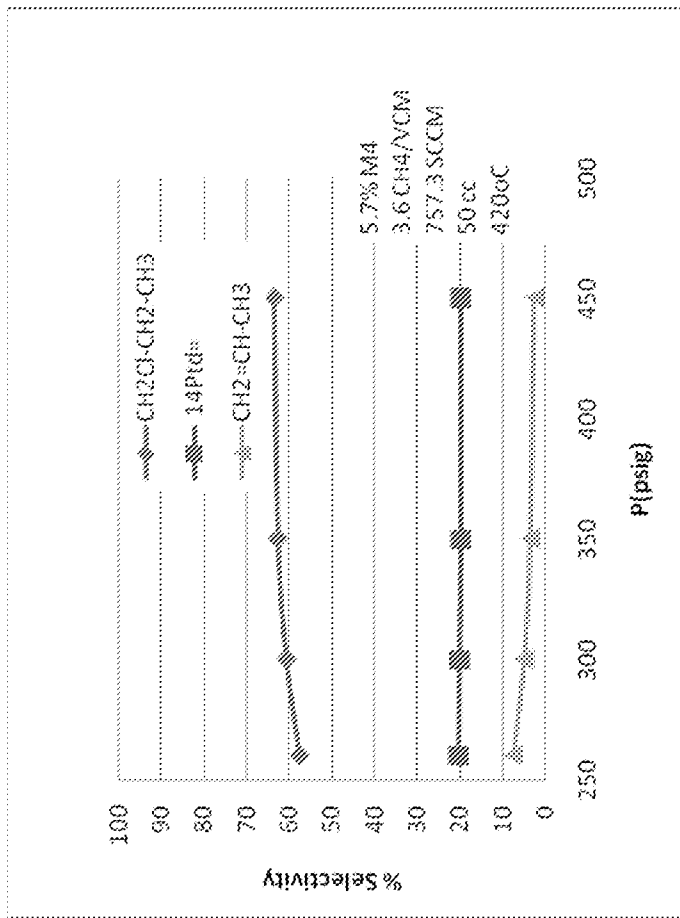

FIGURE 7

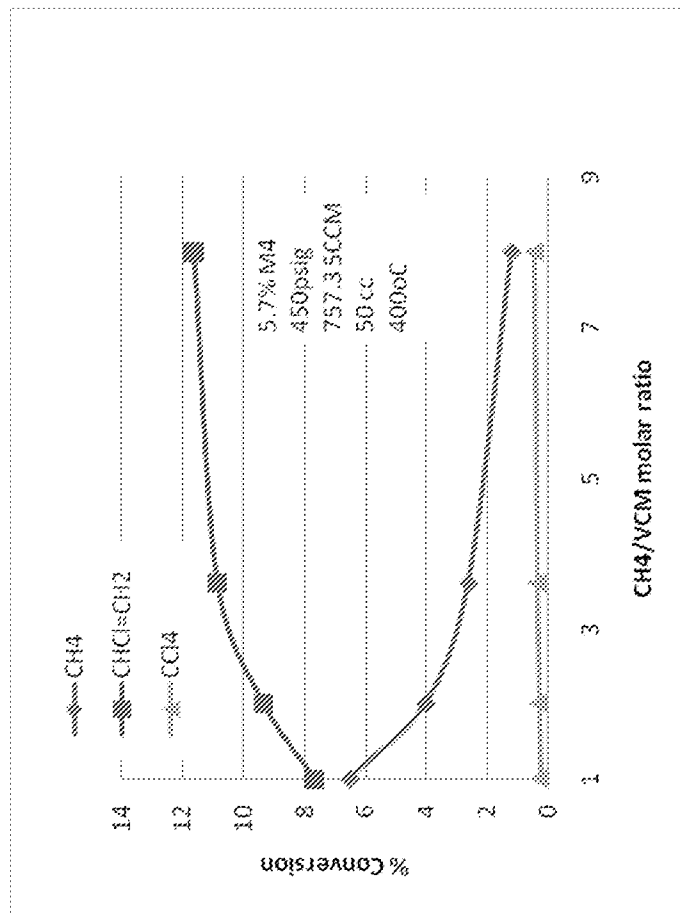

FIGURE 8

9/9

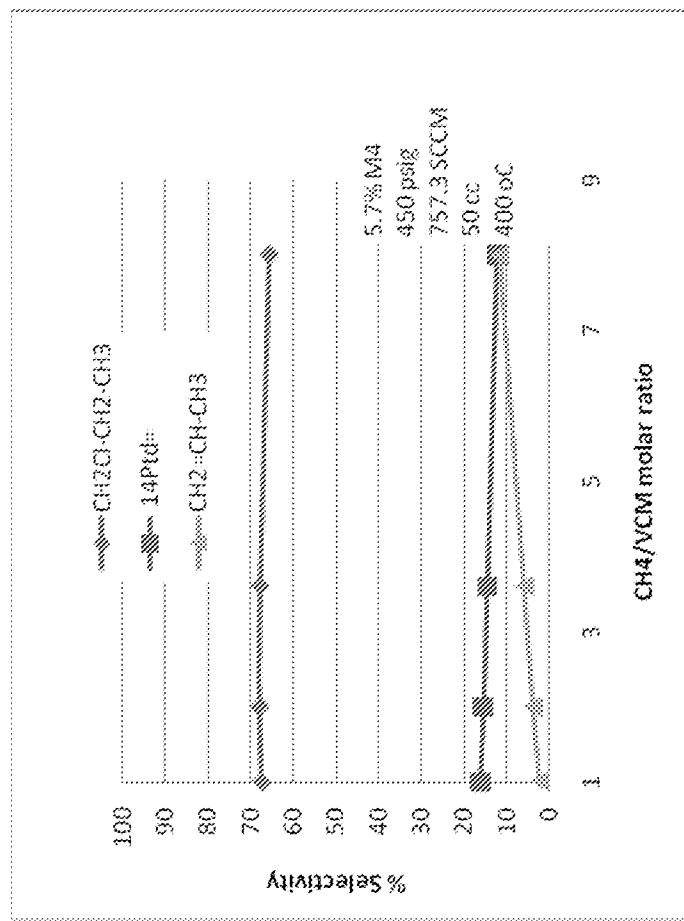

FIGURE 9

INTERNATIONAL SEARCH REPORT

International application No PCT/US2012/071102
--

A. CLASSIFICATION OF SUBJECT MATTER
INV. C07C2/86 C07C11/06 C07C11/173
 ADD.

According to International Patent Classification (IPC) or to both national classification and IPC

B. FIELDS SEARCHED

Minimum documentation searched (classification system followed by classification symbols)
C07C

Documentation searched other than minimum documentation to the extent that such documents are included in the fields searched

Electronic data base consulted during the international search (name of data base and, where practicable, search terms used)
EPO-Internal , CHEM ABS Data

C. DOCUMENTS CONSIDERED TO BE RELEVANT

Category*	Citation of document, with indication, where appropriate, of the relevant passages	Relevant to claim No.
A	US 2 435 983 A (LOUIS SCHMERLING) 17 February 1948 (1948-02-17) claim 1 -----	1-14
A	LU 52 247 A1 (EL PASO PRODUCTS COMPANY) 28 December 1966 (1966-12-28) claims 1-9 table 1 -----	1-14

Further documents are listed in the continuation of Box C. See patent family annex.

* Special categories of cited documents :

<p>"A" document defining the general state of the art which is not considered to be of particular relevance</p> <p>"E" earlier application or patent but published on or after the international filing date</p> <p>"L" document which may throw doubts on priority claim(s) or which is cited to establish the publication date of another citation or other special reason (as specified)</p> <p>"O" document referring to an oral disclosure, use, exhibition or other means</p> <p>"P" document published prior to the international filing date but later than the priority date claimed</p>	<p>"T" later document published after the international filing date or priority date and not in conflict with the application but cited to understand the principle or theory underlying the invention</p> <p>"X" document of particular relevance; the claimed invention cannot be considered novel or cannot be considered to involve an inventive step when the document is taken alone</p> <p>"Y" document of particular relevance; the claimed invention cannot be considered to involve an inventive step when the document is combined with one or more other such documents, such combination being obvious to a person skilled in the art</p> <p>"&" document member of the same patent family</p>
---	---

Date of the actual completion of the international search 3 April 2013	Date of mailing of the international search report 10/04/2013
--	---

Name and mailing address of the ISA/ European Patent Office, P.B. 5818 Patentlaan 2 NL - 2280 HV Rijswijk Tel. (+31-70) 340-2040, Fax: (+31-70) 340-3016	Authorized officer Del anghe, Patri ck
--	--

INTERNATIONAL SEARCH REPORT

Information on patent family members

International application No

PCT/US2012/071102

Patent document cited in search report	Publication date	Patent family member(s)	Publication date
US 2435983	A	17-02-1948	NONE

LU 52247	AI	28-12-1966	AT
			263734 B
			12-08-1968
			BE
			688911 A
			26-04-1967
			CH
			473072 A
			31-05-1969
			LU
			52247 AI
			28-12-1966
			NL
			6615826 A
			08-12-1967
