

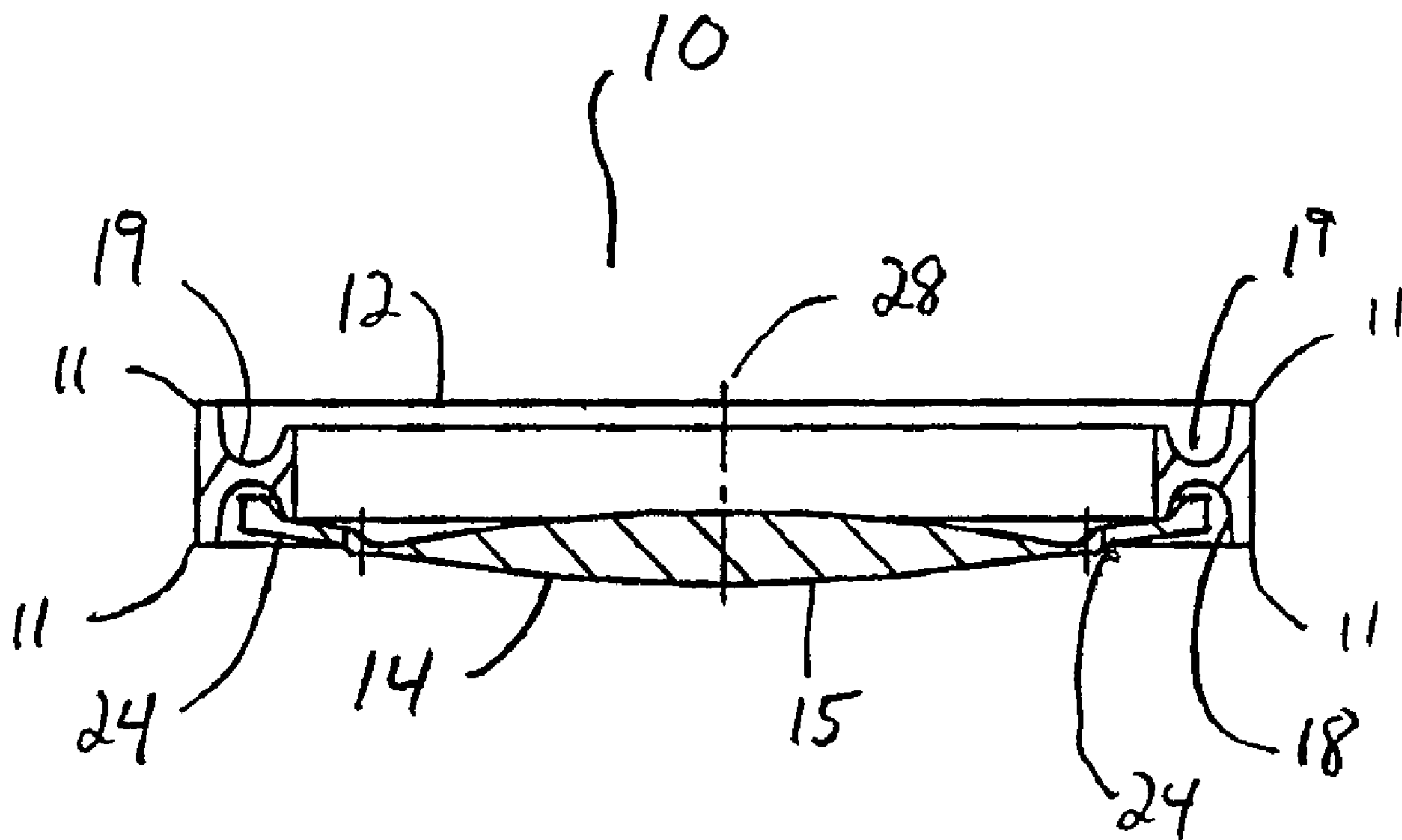

(22) Date de dépôt/Filing Date: 2006/06/27  
 (41) Mise à la disp. pub./Open to Public Insp.: 2007/01/11  
 (45) Date de délivrance/Issue Date: 2010/11/02  
 (30) Priorité/Priority: 2005/07/11 (US11/178,758)

(51) Cl.Int./Int.Cl. *A61F 2/16* (2006.01),  
*A61L 27/14* (2006.01)  
 (72) Inventeurs/Inventors:  
SOYE, PAUL J., CH;  
ZHANG, XIAOXIAO, CH  
 (73) Propriétaire/Owner:  
ALCON, INC., CH  
 (74) Agent: KIRBY EADES GALE BAKER

(54) Titre : SYSTEME DE LENTILLE INTRAOCULAIRE  
 (54) Title: INTRAOCULAR LENS SYSTEM



(57) Abrégé/Abstract:

A two or three component lens system. The first component is a ring-like supporting component that is implanted in the capsular bag following cataract surgery. The first component is a non-optical component and does not correct for any refractive errors. The first component may contain features to help reduce or eliminate PCO. The second component is an optical component that may contain all of the corrective optical power of the lens system. The second component has a pair of tabs for locking the second component within the first component. The first component includes a feature that allows the surgeon to change the position of the second component along the optical axis of the lens system. The third component is optional and is similar to second component and contains some optical power to correct for any residual optical error not corrected by the second component. The second and third components may also be implanted so as to move relative to one another, thereby providing some accommodation.

Abstract of the Disclosure

A two or three component lens system. The first component is a ring-like supporting component that is implanted in the capsular bag following cataract surgery. The first  
5 component is a non-optical component and does not correct for any refractive errors. The first component may contain features to help reduce or eliminate PCO. The second component is an optical component that may contain all of the corrective optical power of the lens system. The second component has a pair of tabs for locking the second component within the first component. The first component includes a feature that allows the surgeon to  
10 change the position of the second component along the optical axis of the lens system. The third component is optional and is similar to second component and contains some optical power to correct for any residual optical error not corrected by the second component. The second and third components may also be implanted so as to move relative to one another, thereby providing some accommodation.

## INTRAOCULAR LENS SYSTEM

### Background of the Invention

5 This invention relates generally to the field of intraocular lenses (IOL) and, more particularly, to multi-lens, micro-incision IOLs.

The human eye in its simplest terms functions to provide vision by transmitting light through a clear outer portion called the cornea, and focusing the image by way of a crystalline lens onto a retina. The quality of the focused image depends on many factors including the  
10 size and shape of the eye, and the transparency of the cornea and the lens.

When age or disease causes the lens to become less transparent, vision deteriorates because of the diminished light which can be transmitted to the retina. This deficiency in the lens of the eye is medically known as a cataract. An accepted treatment for this condition is surgical removal of the lens and replacement of the lens function by an artificial intraocular  
15 lens (IOL).

In the United States, the majority of cataractous lenses are removed by a surgical technique called phacoemulsification. During this procedure, an opening is made in the anterior capsule and a thin phacoemulsification cutting tip is inserted into the diseased lens and vibrated ultrasonically. The vibrating cutting tip liquifies or emulsifies the lens so that  
20 the lens may be aspirated out of the eye. The diseased lens, once removed, is replaced by an artificial lens.

Prior to the present invention, when a cataract or other disease required the removal of the natural lens and replacement with an artificial IOL, the IOL was a monofocal lens. Most IOLs are sold in power increments of +/- 0.5 diopters, and the ultimate power of the lens  
25 depends upon where the lens sits along the optical axis. The fixed increment of the lens, and the slight variation in lens placement can result in less than optimum vision. Although this situation occurs relatively infrequently, and generally is not severe, some patients ultimately are required to use a pair of spectacles or contact lenses for optimum vision. If the power of the implanted lens is incorrect, removal and exchange of a new lens is difficult because of  
30 fibrosis of the lens haptics within the capsular bag.

There have been several prior suggested adjustable power IOLs, none of which have been commercially introduced. For example, U.S. Patent Nos. 5,222,981 (Werblin) and 5,358,520 (Patel), suggest the use of a second or even a third optic that may be  
implanted and attached to a previously implanted primary optic so as to adjust the overall  
35 optic power of the multi-lens system. U.S. Patent Nos. 5,628,798 and 5,800,533 (Eggleston, et al.), disclose a threadedly adjustable IOL wherein the location of the optic along the visual axis may be adjusted. U.S. Patent No. 4,575,373 (Johnson), discloses an

IOL having an optic and an outer ring and connections between the optic and the outer ring made from a heat-shrinkable plastic. The connections are heated with a laser to adjust the power of the IOL. U.S. Patent Nos. 4,919,151 and 5,026,783 (Grubbs, et al.), disclose a lens made from a polymer that swells or otherwise changes shape. The lens is implanted or injected into the capsule bag and selectively polymerized so as to adjust the power of the optic. U.S. Patent No. 5,571,177 (Deacon, et al.), discloses an IOL having haptics with frangible stiffeners. Once implanted in an eye, the stiffeners are selectively cut or heated above their  $t_g$  by laser radiation, causing the stiffness of the haptic to change and adjusting the location of the lens within the capsule bag. The multi-lens designs and the threadedly adjustable designs are not optimized for the reduction or elimination of posterior capsule opacification (PCO). In addition, many of these lenses are not capable of being implanted through a very small (less than 2 millimeters) incision.

Therefore, a need continues to exist for a safe and stable intraocular lens system that provides adjustment of lens power. Such a lens system could be used in cataract or clear lens exchange surgeries.

#### Brief Summary of the Invention

Certain exemplary embodiments may provide an intraocular lens system, comprising: a) a ring-like first component having an inner rim or lip; and b) a second component having an optic portion with an optical power, the second component having a plurality of haptics sized to ride on the inner rim or lip of the first component, so that rotation of the second component causes the second component to move along the optical axis of the lens system and vary the effective power of the lens system, wherein the inner rim or lip has a slightly elliptical, oval, out-of-round or non-circular shape in plan view with a short axis and a long axis, adapted to vary the amount of compression on the haptics of the second component, wherein rotation of the second component so that the haptics are aligned along the short axis will cause the haptics to be more compressed than rotation of the second component so that the haptics are aligned along the long axis, thereby causing the position of the optic portion of the second component to change along the optical axis, while maintaining the stability of the optic portion of the second component in a plane perpendicular to the optical axis.

2a

Embodiments improve upon the prior art by providing a two or three component lens system. The first component is a ring-like supporting component that is implanted in the capsular bag following cataract surgery. The first component is a non-optical component and does not correct for any refractive errors. The first component may contain features to help reduce or eliminate PCO. The second component is an optical component that may contain all of the corrective optical power of the lens system. The second component has a pair of tabs for locking the second component within the first component. The first component includes a feature that allows the surgeon to change the position of the second component along the optical axis of the lens system. The third component is optional and is similar to second component and contains some optical power to correct for any residual optical error not corrected by the second component. The second and third components may also be implanted so as to move relative to one another, thereby providing some accommodation.

Accordingly, one objective of the present invention is to provide a safe and biocompatible intraocular lens.

Another objective of the present invention is to provide a safe and biocompatible intraocular lens that is easily implanted in the posterior chamber.

Still another objective of the present invention is to provide a safe and biocompatible intraocular lens that is stable in the posterior chamber.

5 Still another objective of the present invention is to provide a safe and biocompatible adjustable lens system.

Still another objective of the present invention is to provide a safe and biocompatible lens system that can be implanted through a small incision.

10 Still another objective of the present invention is to provide a safe and biocompatible lens system that helps reduce the incidence of PCO.

Still another objective of the present invention is to provide a safe and biocompatible lens system for use in cataract and/or clear lens exchange surgeries.

These and other advantages and objectives of the present invention will become apparent from the detailed description and claims that follow.

15

#### Brief Description of the Drawing

FIG. 1 is an enlarged perspective view of the first component of the lens system of the present system.

20 FIG. 2 is an enlarged plan view of a first embodiment of the first component of the lens system of the present system.

FIG. 3 is an enlarged cross-sectional view of the first component of the lens system of the present system taken at line 3-3 in FIG. 2.

25 FIG. 4 is an enlarged perspective view of the second component of the lens system of the present system.

FIG. 5 is an enlarged plan view of the second component of the lens system of the present system.

FIG. 6 is an enlarged cross-sectional view of the first component of the lens system of the present system taken at line 6-6 in FIG. 5.

30 FIG. 7 is an enlarged plan view of the third component of the lens system of the present system.

FIG. 8 is an enlarged cross-sectional view of the third component of the lens system of the present system taken at line 8-8 in FIG. 7.

35 FIG. 9 is an enlarged cross-sectional view of the lens system of the present system with the second component installed within the first component.

FIG. 10 is an enlarged plan view of a second embodiment of the first component of the lens system of the present system.

FIG. 11 is an enlarged cross-sectional view of a third embodiment of the first component of the lens system of the present system.

### Detailed Description of the Invention

5

As best seen in FIGS. 1, 4 and 7, lens system 10 of the present invention generally includes a first, or base, component 12, second, or optical, component 14 and may optionally include third, or secondary optical component 16. First component 12 is generally ring-like, and, as best seen in FIG. 3, is generally "I"-shaped in cross section. This "I"-shape forms circumferential anterior channel 19 and posterior channel 18 within the inner diameter of component 12. Such a construction is easy to mold, and provides the flexibility necessary to allow component 12 to be inserted into an eye through a sub-2 millimeter incision. Component 12 is constructed with sharp, square outer edges 11 to help prevent PCO. Component 12 is preferably formed in any suitable overall diameter, for example, between approximately 8.0 millimeters and 12.0 millimeters, a suitable interior diameter, for example, between approximately 6.0 millimeters and 8.5 millimeters and made from a soft, foldable material such as a soft acrylic. Alternatively, component 12 may be made from a material that is stiffer relative to optical component 14 or less stiff relative to optical component 14. By way of example, component 12 may be made of rubber elastomers, such as butyl rubber, latex rubber, natural rubber, pure gum rubber, neoprene rubber, acrylonitrile rubber, styrene-butadiene rubber, ethylene-propylene diene monomer rubber, acrylonitrile-butadiene-styrene (ABS) rubber, epichlorohydrin rubber, hypalon rubber, silicone rubber and siloxane elastomers, such as poly(dimethylsiloxane), polyurethane rubber, viton rubber, ethylene-butylene rubber, isobutylene rubber and elastomers of polyphosphazenes, like poly(bis-trifluoroethoxyphosphazene) oly(dimethylphosphazene) and poly(phenylmethylphosphazene). Preferably, base component 12 may be formed so as to be opaque, such as by frosting or texturing the anterior and/or posterior surfaces of base component 12, or base component may be relatively clear. Base component 12 may also contain a chromophore to block ultraviolet and/or blue and/or green light, such chromophore(s) being well-known in the art.

30

As best seen in FIGS. 4-6, second component 14 is generally circular with an optic 15 having a diameter for example, between approximately 4.0 millimeters and 7.0 millimeters. Optic 15 tapers from being relatively thick in the middle to having a relatively thin, or sharp, edge that connects to a plurality of haptics 24 integrally formed with optic 15 so as to give optical component 14 overall length of between approximately 8.0 millimeters and 10.0 millimeters and preferably, is made from a soft, foldable material such as a soft acrylic. Second component 14 may also contain a chromophore to block ultraviolet and/or blue light, such chromophore(s) being well-known in the art, but unlike base component 12, second

35

component 14 is optically clear. Haptics 24 are connected to optic 15 by connecting portions 26 that are relatively wide in plan view, but relatively thin in cross-section. In addition, haptics 24 contain outwardly projecting tips 32. Such a construction helps to prevent rotation of second component 14 within first component 12 and helps to maintain the stability of optical portion 14 in the plane perpendicular to optical axis 28, but allows some flexibility along optical axis 28. Connecting portions 26 may also contain positioning or manipulation holes 30.

As best seen in FIGS. 7-8, third component 16 is generally circular with an optic 34 having a diameter for example, between approximately 4.0 millimeters and 7.0 millimeters. Third component 16 contains a plurality of haptics 36 integrally formed with optic 34 so as to give third component 16 overall length of between approximately 8.0 millimeters and 10.0 millimeters and preferably, is made from a soft, foldable material such as a soft acrylic. Third component 16 may also contain a chromophore to block ultraviolet and/or blue light, such chromophore(s) being well-known in the art, but unlike base component 12, lens component 16 is optically clear. Haptics 36 are connected to optic 34 by connecting portions 38 that are relatively wide in plan view, but relatively thin in cross-section. In addition, haptics 36 contain outwardly projecting tips 40. Such a construction helps to prevent rotation of third component 16 within second component 12 and helps to maintain the stability of third component 16 in the plane perpendicular to optical axis 28, but allows some flexibility along optical axis 28. In general, third component 16 is of similar construction as second component 14 except, as best seen in FIGS. 6 and 8, third component 16 has less optical power than second component 14 and therefore, is generally thinner than second component 14. Either second component 14 or third component 16 may be constructed to correct any of a variety of possible refractive errors, such as astigmatism (toric), presbyopia (accommodative, pseudo-accommodative or multifocal) or customized to correct higher order aberrations, such refractive errors and optical corrections therefore being well-known in the art.

As best seen in FIG. 9, lens system 10 is assembled by placing tips 32 or 40 of second component 14 or third component 16, respectively, into posterior channel 18 of first component 12, thereby compressing connecting portions 26 and 38 respectively and allowing both haptic 24 and 36 to snap within channel 18. Third component 16 may be installed in a similar manner to correct any residual refractive errors not corrected by second component 14. Preferably, third component 16 is rotated approximately  $90^{\circ}$  relative to second component 14.

As best seen in FIG. 10, in a second embodiment of the present invention, first or base component 12' has an inner rim or lip 150 that is slightly elliptical, oval, out-of-round or non-circular in shape having a short axis 100 and a long axis 102. This slightly oval or otherwise out of round shape will vary the amount of compression on haptics 24 of second component

14. Rotation of second component 14 so that haptics 14 are be aligned along short axis 100 will cause haptics 14 to more compressed than rotation of second component 14 so that haptics 14 are be aligned along long axis 102, thereby changing the position of 15 along optical axis 28 and correspondingly varying the effective refractive power of lens system 10  
5 implanted in an eye.

As best seen in FIG. 11, in a third embodiment of the present invention, inner rim or lip 200 of first or base component 12" contains a plurality of cam ridges 201, 202 and 203 or varying step height. Rotation of second component 14 within base component 12" causes haptics 24 to ride along on ridges 201, 202 or 203, thereby varying the location of optic 15  
10 along optical axis 28 and correspondingly changing the effective refractive power of lens system 10 implanted in an eye.

This description is given for purposes of illustration and explanation. It will be apparent to those skilled in the relevant art that changes and modifications may be made to the invention described above without departing from its scope or spirit.

## Claims:

1. An intraocular lens system, comprising:
  - a) a ring-like first component having an inner rim or lip; and
  - 5 b) a second component having an optic portion with an optical power, the second component having a plurality of haptics sized to ride on the inner rim or lip of the first component, so that rotation of the second component causes the second component to move along the optical axis of the lens system and vary the effective power of the lens system, wherein the inner rim or lip has a slightly elliptical, oval, out-of-round or non-circular shape in plan view with a short axis and  
10 a long axis, adapted to vary the amount of compression on the haptics of the second component, wherein rotation of the second component so that the haptics are aligned along the short axis will cause the haptics to be more compressed than rotation of the second component so that the haptics are aligned along the long axis, thereby causing the position of the optic portion of the second component to change along the optical axis, while maintaining the stability of the optic portion of  
15 the second component in a plane perpendicular to the optical axis.
2. The lens system of claim 1, wherein the first component is opaque.
3. The lens system of claim 1, wherein the first component is stiff relative to the second  
20 component.
4. The lens system of claim 1, wherein the first component is made from a rubber elastomer.
5. The lens system of claim 4, wherein the rubber elastomer is selected from; butyl rubber,  
25 latex rubber, natural rubber, pure gum rubber, neoprene rubber, acrylonitrile rubber, styrene-butadiene rubber, ethylene-propylene diene monomer rubber, acrylonitrile-butadiene-styrene (ABS) rubber, epichlorohydrin rubber, hypalon rubber, silicone rubber and siloxane elastomers including poly(dimethylsiloxane), polyurethane rubber, viton rubber, ethylene-butylene rubber, isobutylene rubber and elastomers of polyphosphazenes including poly(bis-  
30 trifluoroethoxyphosphazene), poly(dimethylphosphazene) or poly(phenylmethylphosphazene).
6. The lens system of claim 1, wherein the second component contains a chromophore to block at least one of ultraviolet, blue and green light.

7. The lens system of claim 1, wherein the first component is made of a soft acrylic.
8. The lens system of any one of claims 1 to 7, wherein the second component is constructed to correct astigmatism.

5

9. The lens system of any one of claims 1 to 7, wherein the second component is customized to correct higher order aberrations.

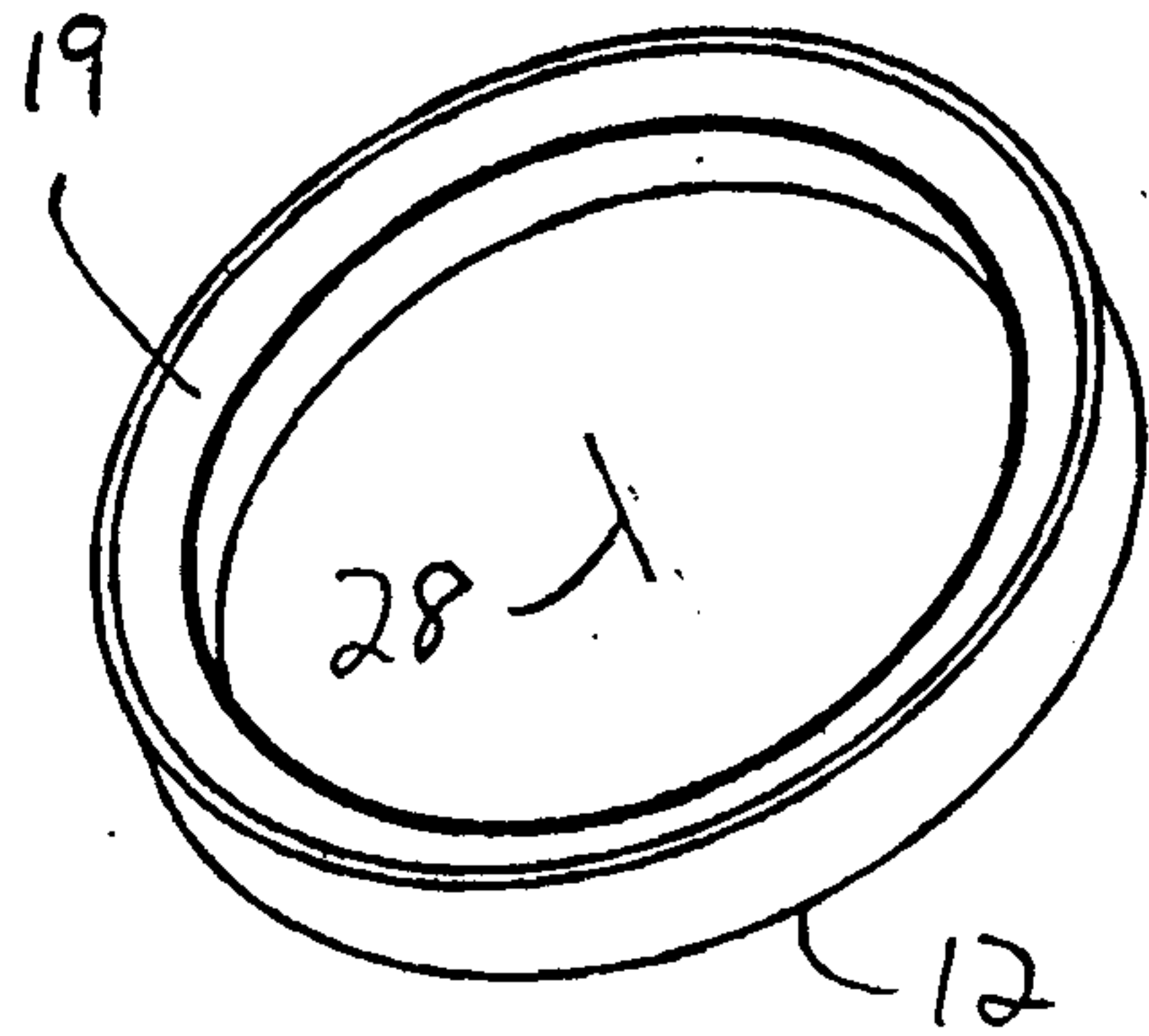

FIG. 1

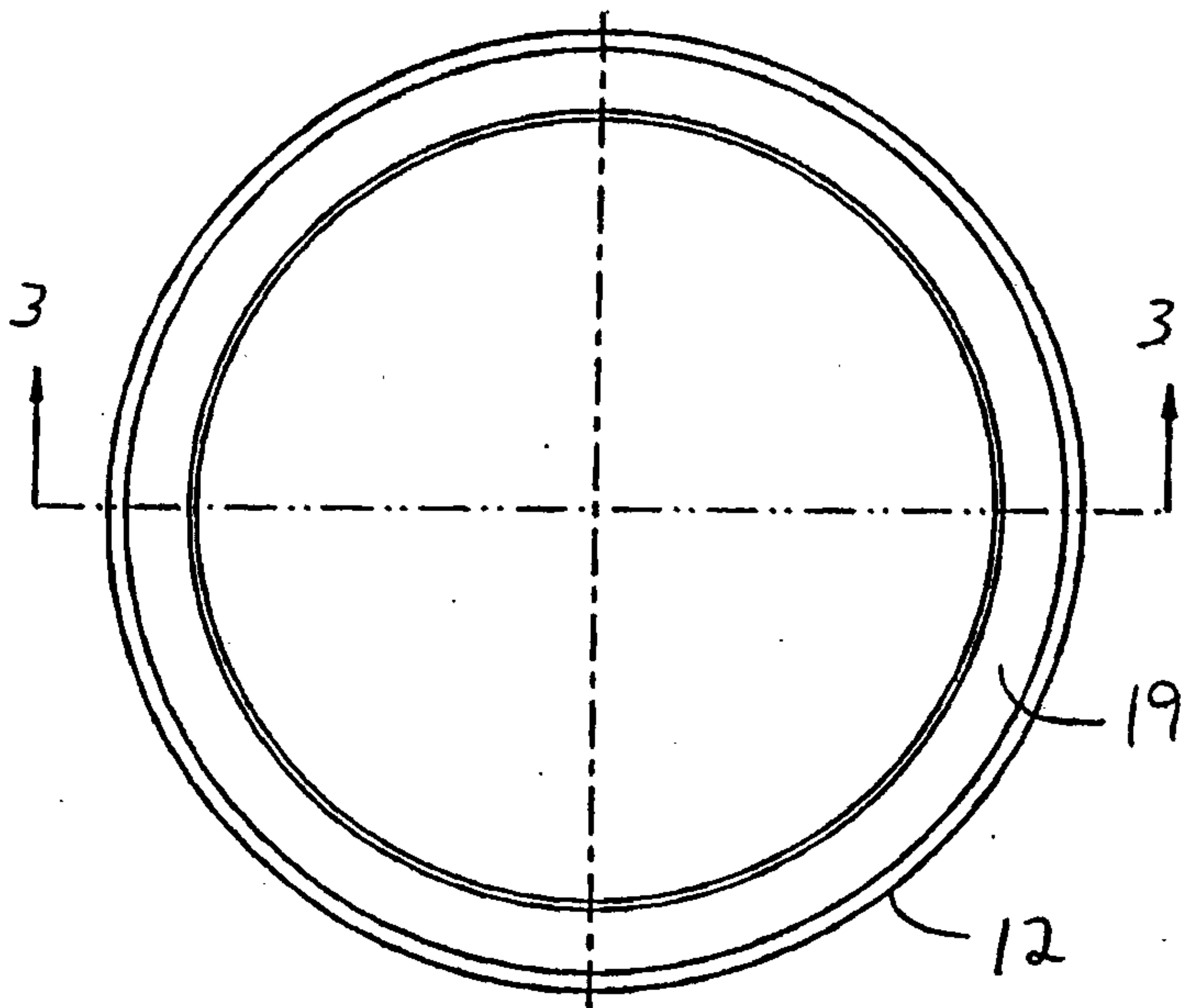

FIG. 2

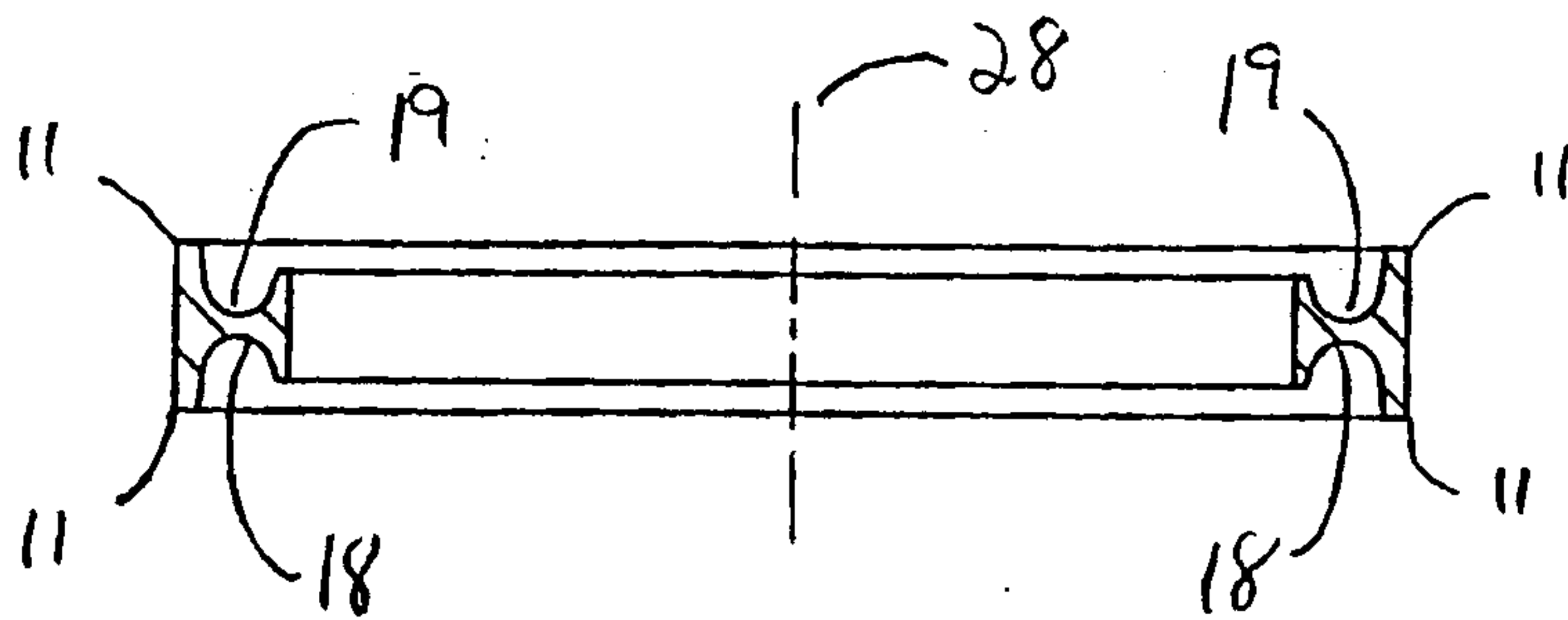

FIG. 3

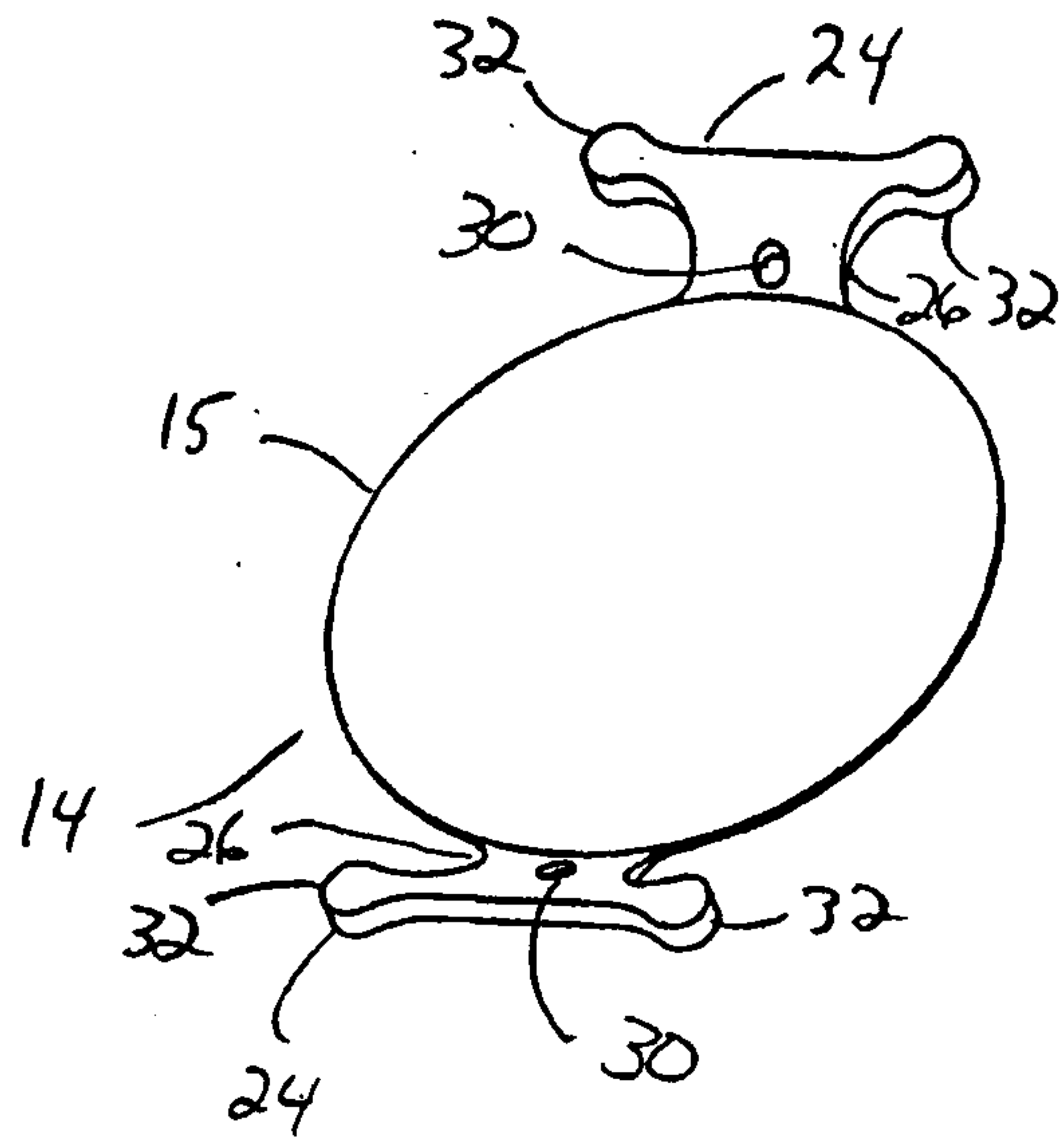

FIG. 4

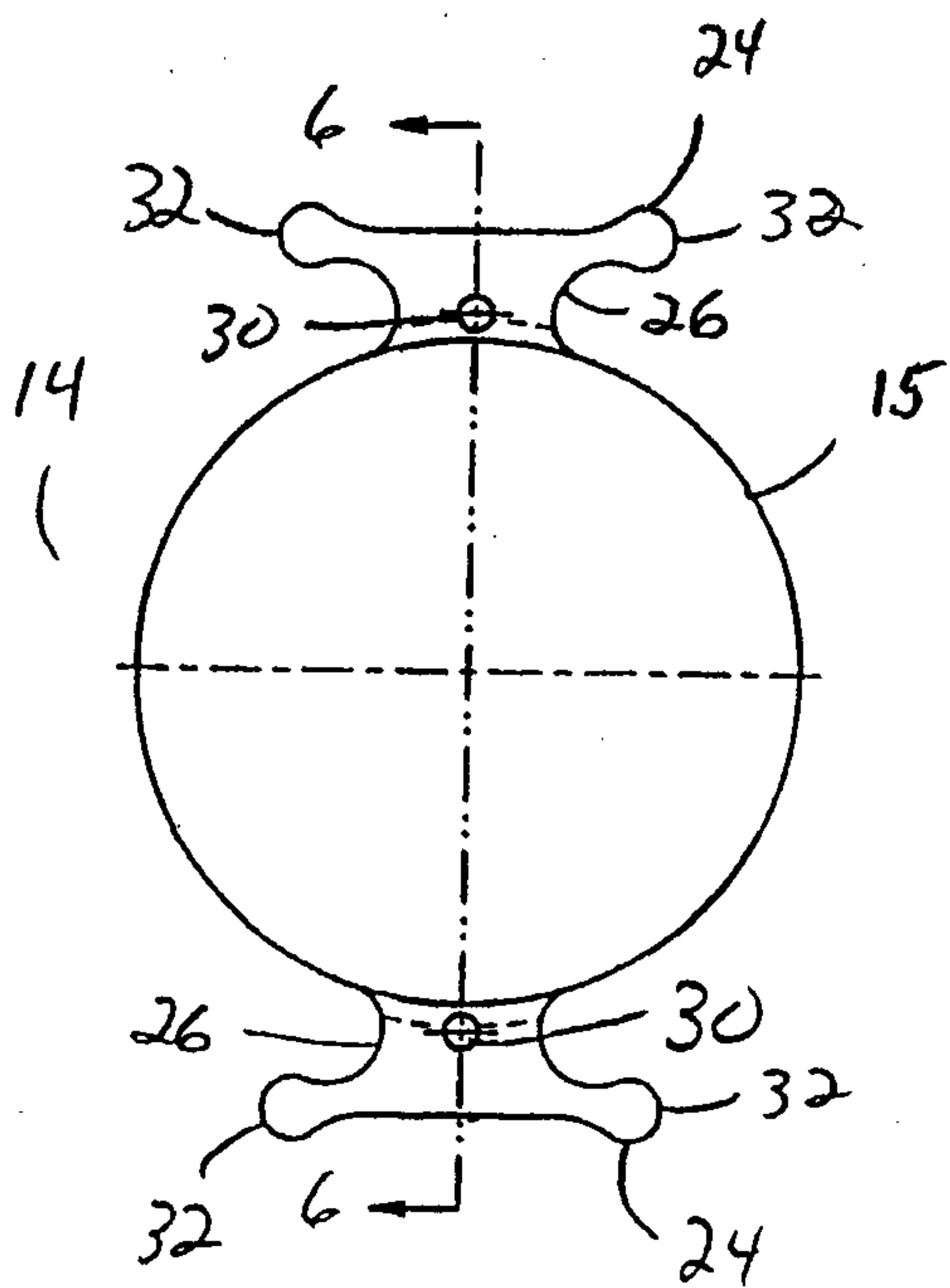

FIG. 5

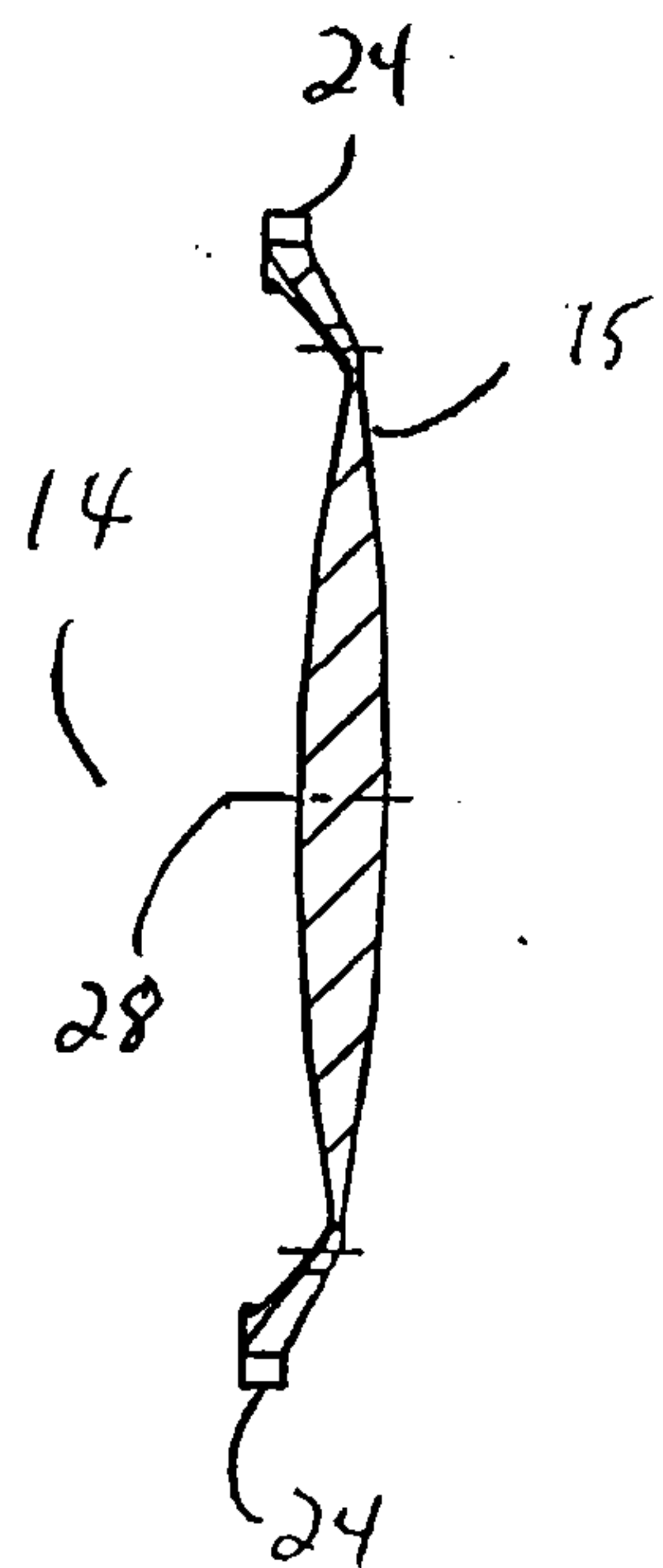

FIG. 6

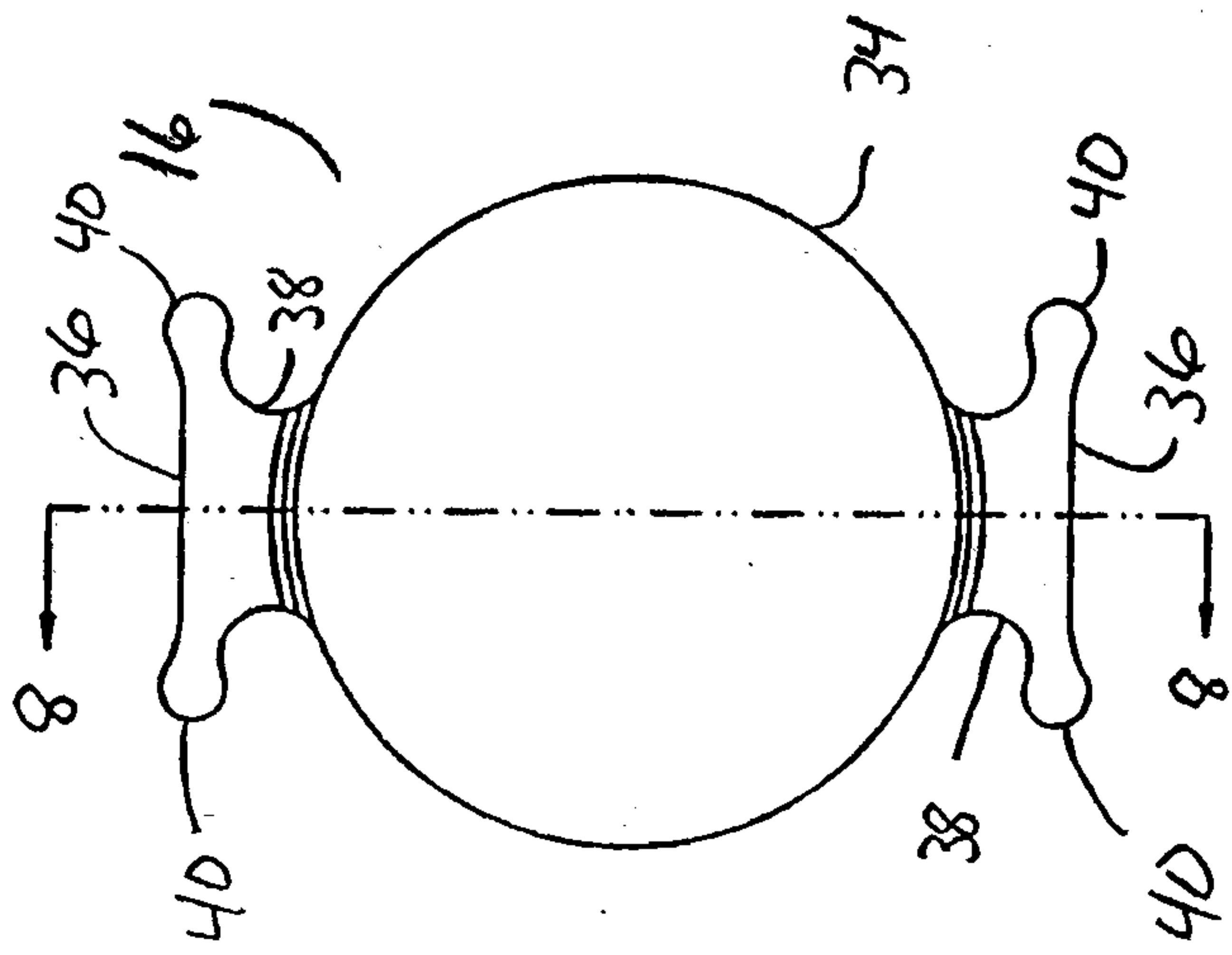

FIG. 7

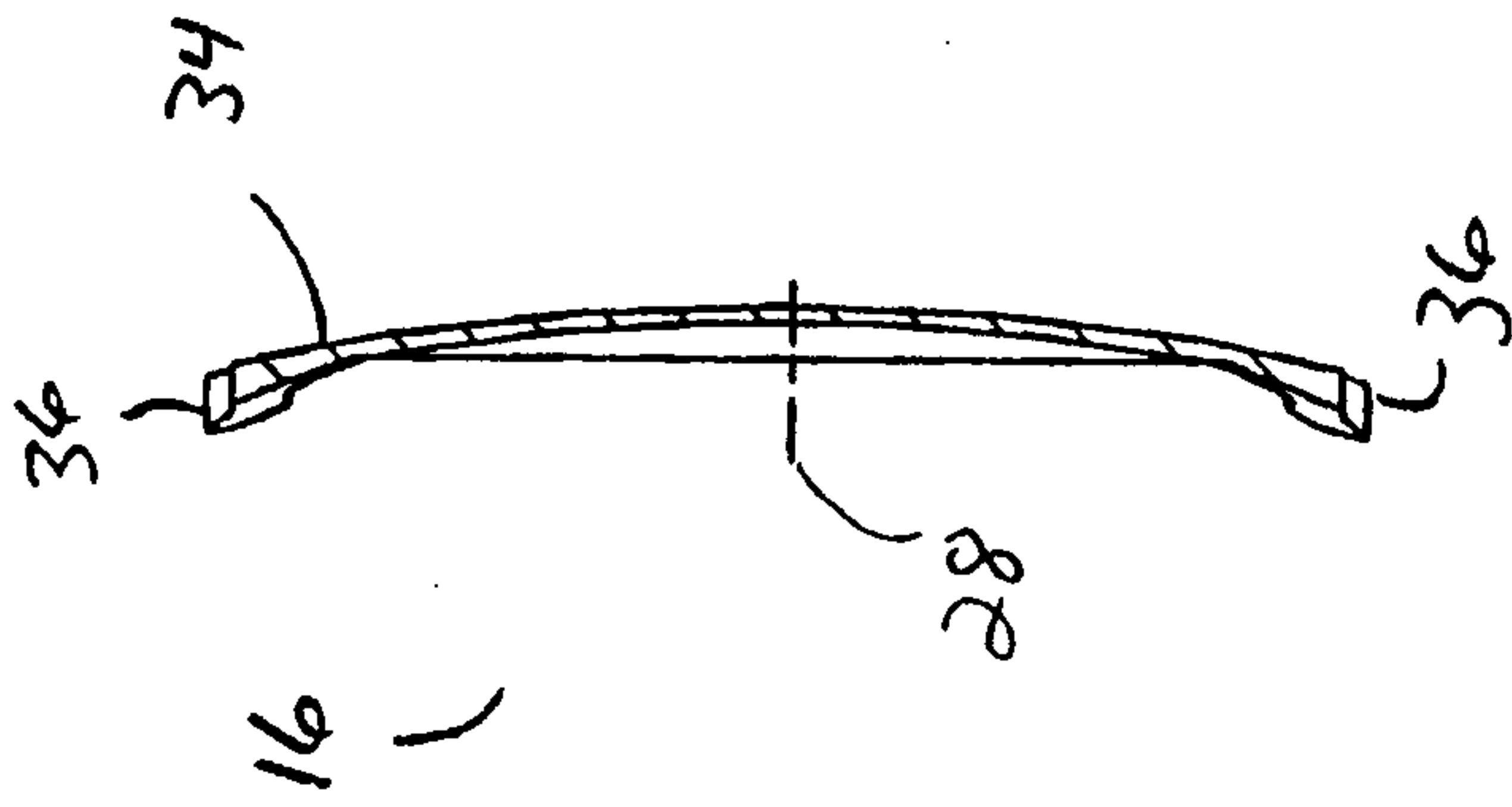

FIG. 8

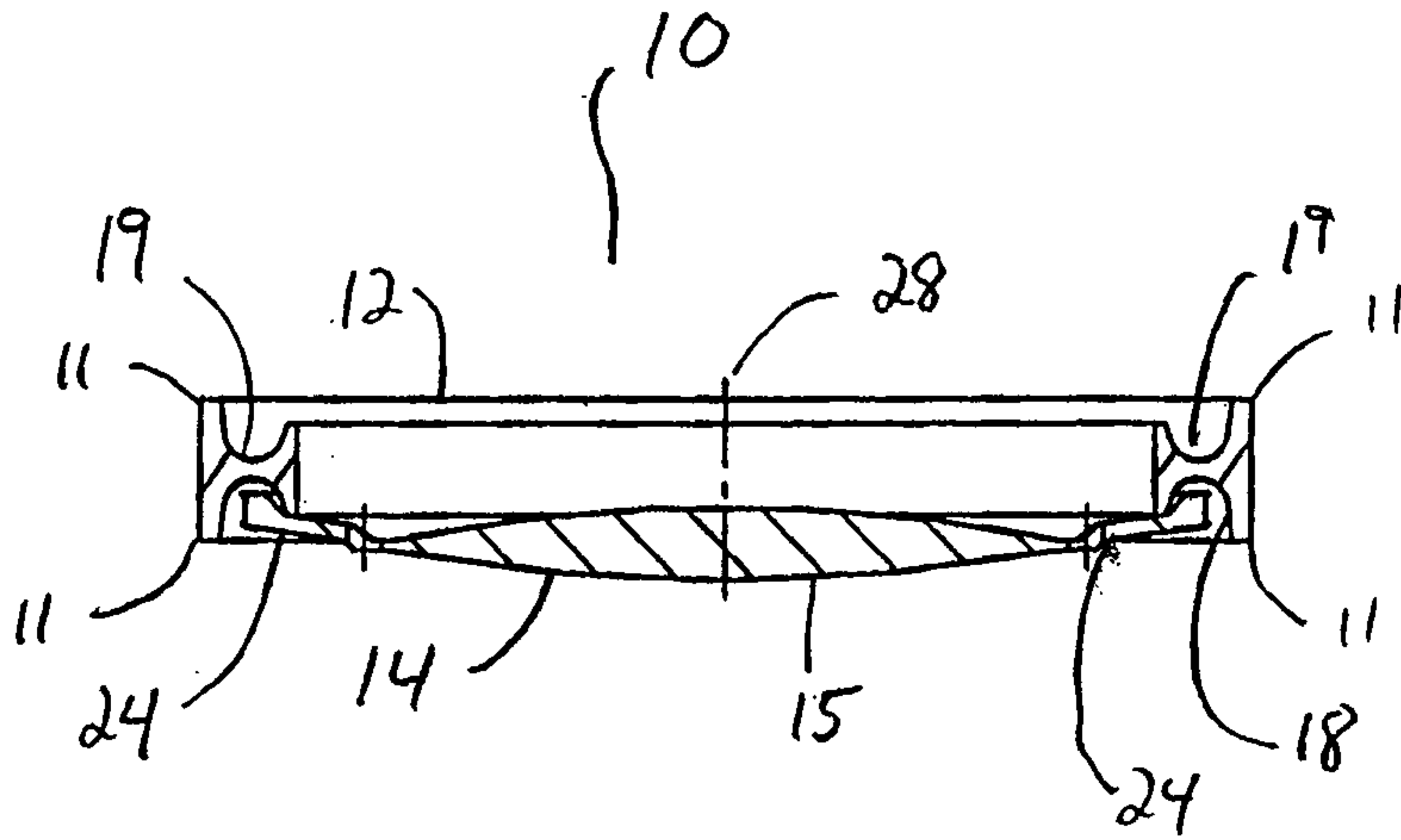

FIG. 9

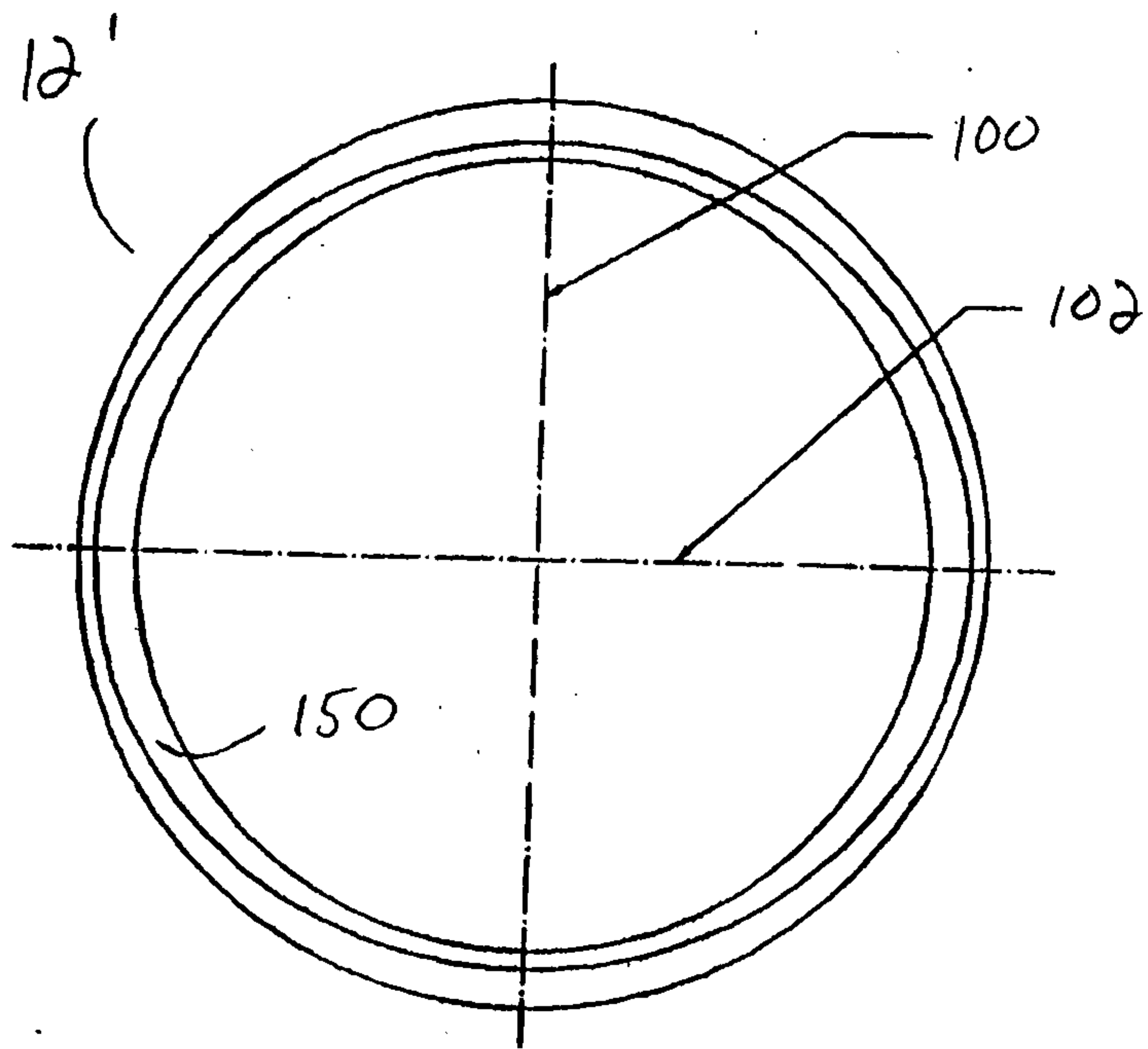

FIG. 10

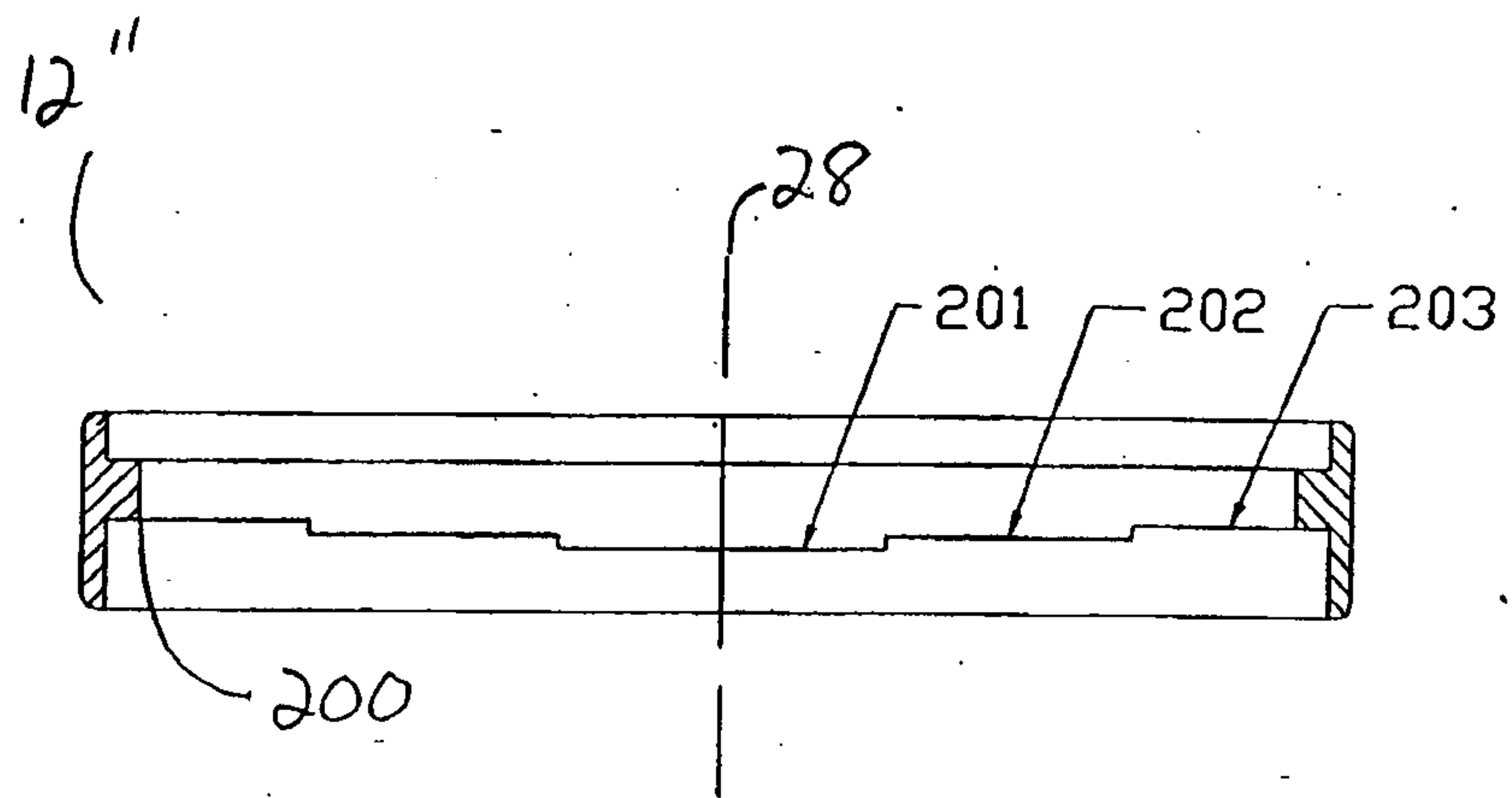

FIG. 11

