



INTERNATIONAL APPLICATION PUBLISHED UNDER THE PATENT COOPERATION TREATY (PCT)

<p>(51) International Patent Classification ⁷ : C12Q 1/68</p>	<p>A2</p>	<p>(11) International Publication Number: WO 00/68424 (43) International Publication Date: 16 November 2000 (16.11.00)</p>
<p>(21) International Application Number: PCT/EP00/04591 (22) International Filing Date: 4 May 2000 (04.05.00) (30) Priority Data: 60/132,705 5 May 1999 (05.05.99) US (71) Applicants (for all designated States except US): INSTITUT CURIE [FR/FR]; 26, rue d'Ulm, F-75248 Paris Cedex 05 (FR). CENTRE NATIONAL DE LA RECHERCHE SCIENTIFIQUE (C.N.R.S.) [FR/FR]; 3, Rue Michel Ange, F-75794 Paris Cedex 16 (FR). (72) Inventors; and (75) Inventors/Applicants (for US only): CAPPELLEN, David [FR/FR]; 8, avenue le Pont l'Evêque, F-14810 Merville-Franceville (FR). CHOPIN, Dominique [FR/FR]; 23, avenue de la Marne, F-94000 Creteil (FR). RAD-VANYI, François [FR/FR]; 36, rue des Potiers, F-92260 Fontenay-aux-Roses (FR). RICOL, David [FR/FR]; Bât. K, 40, rue Pascal, F-75013 Paris (FR). THIERY, Jean-Paul [FR/FR]; 16, rue Vandrezanne, F-75013 Paris (FR). (74) Agents: PEAUCELLE, Chantal et al.; Cabinet Armengaud Ainé, 3, avenue Bugeaud, F-75116 Paris (FR).</p>		<p>(81) Designated States: AE, AG, AL, AM, AT, AU, AZ, BA, BB, BG, BR, BY, CA, CH, CN, CR, CU, CZ, DE, DK, DM, DZ, EE, ES, FI, GB, GD, GE, GH, GM, HR, HU, ID, IL, IN, IS, JP, KE, KG, KP, KR, KZ, LC, LK, LR, LS, LT, LU, LV, MA, MD, MG, MK, MN, MW, MX, NO, NZ, PL, PT, RO, RU, SD, SE, SG, SI, SK, SL, TJ, TM, TR, TT, TZ, UA, UG, US, UZ, VN, YU, ZA, ZW, ARIPO patent (GH, GM, KE, LS, MW, SD, SL, SZ, TZ, UG, ZW), Eurasian patent (AM, AZ, BY, KG, KZ, MD, RU, TJ, TM), European patent (AT, BE, CH, CY, DE, DK, ES, FI, FR, GB, GR, IE, IT, LU, MC, NL, PT, SE), OAPI patent (BF, BJ, CF, CG, CI, CM, GA, GN, GW, ML, MR, NE, SN, TD, TG).</p> <p>Published <i>Without international search report and to be republished upon receipt of that report.</i></p>
<p>(54) Title: MEANS FOR DETECTING AND TREATING PATHOLOGIES LINKED TO FGFR3</p>		
<p>(57) Abstract</p> <p>The invention relates to a method for detecting carcinomas in a biological sample, comprising identifying FGFR3 mutations.</p>		

FOR THE PURPOSES OF INFORMATION ONLY

Codes used to identify States party to the PCT on the front pages of pamphlets publishing international applications under the PCT.

AL	Albania	ES	Spain	LS	Lesotho	SI	Slovenia
AM	Armenia	FI	Finland	LT	Lithuania	SK	Slovakia
AT	Austria	FR	France	LU	Luxembourg	SN	Senegal
AU	Australia	GA	Gabon	LV	Latvia	SZ	Swaziland
AZ	Azerbaijan	GB	United Kingdom	MC	Monaco	TD	Chad
BA	Bosnia and Herzegovina	GE	Georgia	MD	Republic of Moldova	TG	Togo
BB	Barbados	GH	Ghana	MG	Madagascar	TJ	Tajikistan
BE	Belgium	GN	Guinea	MK	The former Yugoslav Republic of Macedonia	TM	Turkmenistan
BF	Burkina Faso	GR	Greece			TR	Turkey
BG	Bulgaria	HU	Hungary	ML	Mali	TT	Trinidad and Tobago
BJ	Benin	IE	Ireland	MN	Mongolia	UA	Ukraine
BR	Brazil	IL	Israel	MR	Mauritania	UG	Uganda
BY	Belarus	IS	Iceland	MW	Malawi	US	United States of America
CA	Canada	IT	Italy	MX	Mexico	UZ	Uzbekistan
CF	Central African Republic	JP	Japan	NE	Niger	VN	Viet Nam
CG	Congo	KE	Kenya	NL	Netherlands	YU	Yugoslavia
CH	Switzerland	KG	Kyrgyzstan	NO	Norway	ZW	Zimbabwe
CI	Côte d'Ivoire	KP	Democratic People's Republic of Korea	NZ	New Zealand		
CM	Cameroon			PL	Poland		
CN	China	KR	Republic of Korea	PT	Portugal		
CU	Cuba	KZ	Kazakstan	RO	Romania		
CZ	Czech Republic	LC	Saint Lucia	RU	Russian Federation		
DE	Germany	LI	Liechtenstein	SD	Sudan		
DK	Denmark	LK	Sri Lanka	SE	Sweden		
EE	Estonia	LR	Liberia	SG	Singapore		

Means for detecting and treating pathologies linked to FGFR3

5

The invention relates to means, i.e. method and drugs, for detecting and treating, respectively, pathologies linked to FGFR3 and/or to the FGFR3 pathway.

Fibroblast growth factor receptor 3 (FGFR3) belongs to a family of
10 structurally related tyrosine kinase receptors (FGFRs 1-4) encoded by four different genes. These receptors are glycoproteins composed of two to three extracellular immunoglobulin (Ig)-like domains, a transmembrane domain and a split tyrosine-kinase domain. Alternative mRNA splicing results in many different receptors variants. Isoforms FGFR3-IIIb and FGFR3-IIIc result from a mutually exclusive splicing event in
15 which the second half of the juxtamembrane Ig-like domain is encoded either by the 151 nucleotides long exon 8 (IIIb variant) or the 145 nucleotides long exon 9 (IIIc variant).

Specific point mutations in the *FGFR3* gene which affect different domains of the protein are associated with autosomal dominant human skeletal disorders such as hypochondroplasia, achondroplasia, severe achondroplasia with developmental
20 delay and acanthosis nigricans and thanatophoric dysplasia. Several reports have demonstrated that these mutations lead to constitutive activation of the receptor. Taking into account this result, together with the skeletal overgrowth observed in mice homozygous for null alleles of *Fgfr3*, FGFR3 appears as a negative regulator of bone growth.

25 In contrast with this inhibitory role, an oncogenic role has been proposed for *FGFR3* in multiple myeloma (MM) development. In this malignant proliferation of plasma cells, a t(4;14)(p16.3;q32.3) chromosomal translocation with breakpoints located 50 to 100 Kb centromeric to *FGFR3* is present in 20-25% of the cases and is associated with overexpression of FGFR3.

30 In very rare cases (2 out of 12 MM cell lines and 1 out of 85 primary MM tumours), activating mutations of *FGFR3* previously identified in human skeletal disorders have been found, but always accompanied by the t(4;14)(p16.3;q32.3) translocation.

35 By investigating various cancers, the inventors have surprisingly found a role for FGFR3 in solid tumours, in particular in cancers originating from epithelial tissues, carcinomas.

The involvement of FGFR3 in such solid tumour development is linked to a constitutional activation : it may be activated by an autocrinal loop (ligand self-

production) and/or by activating mutations in *FGFR3*. Surprisingly, such mutations are found in primary tumours and are somatic mutations (genomic DNA mutations).

So far, the only *FGFR3* isoform which has been identified in epithelium is the *FGFR3*-IIIb isoform.

5 The invention thus relates to a method and kits for detecting such pathologies.

According to another aspect, the invention also relates to drugs capable of treating such pathologies.

10 According to still another aspect, it relates to transgenic animals enabling the efficiency of such drugs to be tested as well as to cell lines transfected with the different forms of *FGFR3* (useful *in vitro* and *in vivo*).

The method of the invention for detecting carcinomas in a biological sample comprises identifying *FGFR3* mutations.

15 Standard methods can apply for such an identification such as immunohistochemistry, or detection of the corresponding RNA, DNA, and encoded protein contained in said sample, particularly after extraction thereof. A common way for such a detection comprises amplifying by PCR, RT-PCR or RT-PCR SSCP (single strand conformation polymorphism) with *FGFR3* specific primers and revealing the amplification products according to the usual methods. A corresponding embodiment is exemplified in the examples given hereinafter. Another common way comprises the use of antibodies and the detection of the antigen-antibody reaction with appropriate labelling.

25 The activating function of a mutation can be determined by observation of activating signals such as receptor phosphorylation, cell proliferation (e.g. thymidine incorporation) or indirect effects such as calcium influx, phosphorylation of target sequences.

More particularly, said identification comprises screening for single nucleotide mutation(s) in the genomic DNA and/or its products, i.e. RNA, protein, the term "product" also encompassing cDNA.

30 Particularly, said method comprises screening for mutations creating cysteine residues in the extracellular or transmembrane domains of the receptor.

Alternatively, or in combination with the foregoing embodiment, it comprises screening for mutations resulting in at least one amino-acid substitution in the kinase domain of the receptor.

35 It particularly comprises screening of activating mutation(s) of *FGFR3*, notably such as above-described.

More particularly, the method of the invention comprises screening for mutation(s) in exon 7, encoding the junction between immunoglobulin-like domains II

and III of FGFR3, in exon 10, encoding the transmembrane domain, in exon 15, encoding the tyrosine kinase domain I, and/or in the exon encoding the C-terminal part.

Advantageously, the method of the invention comprises screening for missense mutations such as implicated in thanatophoric dysplasia, NSC, achondroplasia, saddan, or hypochondroplasia.

Such FGFR3 mutations notably comprise R248C, S249C, G372C, S373C, Y375C, K652E, K652M, J809G, J809C, J809R, J809L, P250R, G377C, G382R, A393E, N542K (codons are numbered according to FGFR3-IIIb cDNA open reading frame).

The following FGFR3 mutations will be particularly identified : R248C, S249C, G372C, K652E and Y375C.

Said biological sample used in the method of the invention will advantageously comprise a tissue, bone marrow, or a fluid such as blood, urine, deriving from a warm-blooded animal, and more especially from a human.

Said method is particularly useful for detecting carcinomas, such as human bladder and cervix carcinomas. A major issue in superficial bladder cancer is to distinguish tumours which will progress from those which will not. Insights into the genetic and epigenetic alterations involved in bladder cancer is expected to provide useful information to facilitate this distinction. In that respect, the invention provides means to resolve the dilemma between a bladder-sparing strategy versus cystectomy and will contribute to a more individualised intravesical instillation and endoscopic monitoring policy.

Indeed, as shown by the results given in the examples, *FGFR3* appears to be a major oncogene in Ta, T1 bladder carcinomas. The *FGFR3* mutations appear to be frequently associated with tumours that do not progress. Multivariate analysis showed that *FGFR3* mutation status remained a statistically significant predictor of good outcome. *FGFR3* mutations thus provide clear-cut information, which may complement stage and grade. The use of these mutations alone and/or in combination with other predictors of tumour aggressiveness will then provide relevant prognostic information.

Said method, will also be used for detecting for example lung, breast, colon, skin cancers.

The method of detection according to the invention applies to the diagnostic of carcinomas, as well to the prognosis, or the follow-up of the efficiency of a therapy.

Said method will advantageously be performed by using kits comprising the appropriate reagents and a notice of use.

According to another aspect, the invention relates to drugs having an anti-proliferative effect on carcinoma cells. Such drugs comprise, as active principle(s)

agent(s) which act by inhibition of FGFR3 DNA synthesis or by inhibition of its expression products (RNA, proteins). Particularly, such drugs contain tyrosine kinase inhibitors specific for FGFR3.

5 Other appropriate inhibitors comprise antibodies directed against FGFR3, and particularly against at least one extracellular Ig-like domain thereof. Advantageously said antibodies are specific for FGFR3-IIIb. Preferred antibodies are monoclonal ones, and particularly antibodies modified so that they do not induce immunogenic reactions in a human body (e.g. humanized antibodies).

10 Other appropriate inhibitors comprise antisens oligonucleotides directed against a wild or mutated *FGFR3* isoform.

The administration and the posology of said inhibitors will be determined by the one skilled in the art depending on the carcinoma to be treated, the weight and age of the patient. For example, antibodies will be administered by the injectable route.

15 The invention thus gives means of great interest for detecting and treating carcinomas, taking into account the fact that cancers originating from epithelial tissues (carcinomas) represent approximately 90 % of malignant neoplasms.

The invention also relates to cell lines capable of expressing FGFR3 mutated forms. Particularly, the invention relates to FGFR3 S249C mutated forms. T24 cell lines constitutively expressing FGFR3 S249C mutated forms and HeLa cell lines
20 expressing FGFR3 S249C mutated forms in an inducible manner have thus been obtained (for example see ref.(6)).

By injecting such cell lines to nude mice, an increased tumorigenicity was observed.

25 According to the invention, such cell lines are useful *in vitro* (follow up of the receptor phosphorylation) or *in vivo* (examination of the tumorigenicity of nude mice) to study the inhibitor effect against FGFR3.

Cell lines transfected with FGFR2, FGFR1 or FGFR4 are particularly useful for studying the specificity of inhibitors to be tested.

30 According to still another object, the invention relates to constructions capable of expressing by transgenesis a FGFR3 mutated form in epitheliums and the transgenic animals thus obtained which are characterized by the fact that they comprise such constructions.

35 Examples of constructions intended for injection in animal germinal cells comprise a keratin promoter, particularly keratin 14 promoter and cDNA of mutated FGFR3.

Other advantages and characteristics of the invention will be given in the following examples wherein it will be referred to

- figures 1A - 1B which give FGFR3-IIIb gene activating mutations in primary tumours,

5 - figures 2A - 2E which refer to FGFR3-IIIb wild (2A) and mutated pro-oncogenic (2B-2T) sequences. It will be noted that the sequences of figures 2B to 2T, as such, enter into the scope of the invention. There may be silent polymorphisms all along the sequence, so there may be in fact several possible sequences for each mutant, and

10 - figures 3a and 3b which respectively represent a) Kaplan-Meier progression-free survival curves according to *FGFR3* mutations (dotted line: mutated *FGFR3*, solid line: non-mutated *FGFR3*; log rank test $p=0.014$) ; b) Kaplan-Meier disease-specific survival curves according to *FGFR3* mutations (dotted line: mutated *FGFR3*, solid line: non-mutated *FGFR3*; log rank test $p=0.007$)

15 Example 1 : *FGFR3* gene mutations in bladder and cervix carcinomas

FGFR3-IIIb and *FGFR3-IIIc* transcript levels were examined by reverse transcription-polymerase chain reaction (RT-PCR) in 76 primary bladder carcinomas and 29 primary invasive cervical carcinomas.

20 *FGFR3-IIIb*, the sole isoform to be significantly expressed, was detected in 72 out of 76 (94%) bladder carcinomas and 27 out of 29 (93%) cervical carcinomas.

A PCR-SSCP analysis was then conducted on both reverse transcribed RNA and genomic DNA to screen for *FGFR3* coding sequence variants in 26 bladder and 12 cervix cancers expressing the gene. The results are illustrated in figures 1a and 1b which gives the identification of *FGFR3* gene mutations in human carcinomas :

25 - a: gives the identification of somatic mutations by direct sequencing of PCR products. Normal constitutional DNA ; Tumour, tumour DNA.

- b: gives *FGFR3* mutations associated with skeletal disorders and cancers.

The schematic structure of *FGFR3* is depicted (Ig I-III, immunoglobulin like domains ; TM, transmembrane domain ; TK-1 and -2, tyrosine kinase domains) and the locations of the known human missense mutations associated with thanatophoric dysplasia (TD) and severe achondroplasia (SADDAN), bladder and cervix carcinomas (carc.) and multiple myeloma (MM) are indicated. Usual amino acid abbreviations are used to point out the mutation found in each pathological situation. The mutations at
35 codon 807 incriminated in TD replaces a Stop codon (J) by an amino acid (G, C, R or L) and the mRNA thus continues to be translated until another in-frame Stop codon is reached 423 nucleotides downstream thus leading to a 141 amino acid longer protein.

Abnormally migrating bands were observed for certain samples (Fig. 1a) and direct sequencing of PCR products revealed single nucleotide substitutions in 9 out of 26 bladder carcinomas (35 %) and 3 out of 12 (25 %) cervix carcinomas (Fig. 1b and table 1).

5

Table 1

Summary of FGFR3 gene mutations in primary bladder and cervix cancers					
Sample	Histopathol.	Codon	Nt Position	Mutation	Predicted effect
1447, bladder	carc., Ta G2	249	746	TCC to TGC	Ser to Cys
342, bladder	carc., T1a G1	249	746	TCC to TGC	Ser to Cys
813, bladder	carc., T1a G1	372	1114	GGC to TGC	Gly to Cys
1393.1, bladder	carc., T1a G3	249	746	TCC to TGC	Ser to Cys
506, bladder	carc., T1b G2	372	1114	GGC to TGC	Gly to Cys
1084, bladder	carc., T1b G3	652	1954	AAG to GAG	Lys to Glu
745.1, bladder	carc., T2 G3	248	742	CGC to TGC	Arg to Cys
1077, bladder	carc., T3 G2	249	746	TCC to TGC	Ser to Cys
1210, bladder	carc., T3 G2	249	746	TCC to TGC	Ser to Cys
4.13, cervix	carc., stage II	249	746	TCC to TGC	Ser to Cys
4.139, cervix	carc., stage II	249	746	TCC to TGC	Ser to Cys
6.96.1, cervix	carc., stage II	249	746	TCC to TGC	Ser to Cys

Histopathol., histopathological classification of the tumours (carc., carcinoma : TNM and HUGO classifications are used respectively for bladder and cervix cancers) ; codon and mutated nucleotide (Nt position) are numbered according to FGFR3-IIIb cDNA open reading frame.

Mutations were found in the following exons

- exon 7, encoding the junction between immunoglobulin-like domains II and III of FGFR3 (one C-to-T transition at codon 248 in patient 745.1 and a C-to-G substitution at codon 249 in patient 1447) ;

- exon 10, encoding the transmembrane domain (a G-to-T-transversion at codon 372 in patient 813)

- exon 15, encoding the tyrosine kinase domain II (a A-to-G transition at codon 652 in patient 1084).

Analysis of matched constitutional DNA from the patients for which such material was available (n=8) demonstrated the somatic nature of these *FGFR3* mutations (Figure 1).

Strikingly, each of the FGFR3 missense mutations identified herein, i.e. R248C, S249C, G372C and K652E, are implicated in thanatophoric dysplasia (TD).

Given the presence of two additional amino-acids in the IIIb isoform expressed in epithelial cancers as compared to the IIIc isoform expressed in bone, the G372C and K652E mutations are indeed equivalent to the G370C and K650E mutations responsible for TD.

5 The S249C mutation was the most commonly observed, affecting 5 out of 9 (55 %) bladder cancers and all of the cervical cancers (3 out of 3, 100 %) in which *FGFR3* gene alterations have been identified so far.

The R248C, S249C and G372/370C mutations create cysteine residues in the extracellular or transmembrane domains of the receptor and the K652/650E mutations results in amino-acid substitution in the kinase domain of the receptor.

10 Example 2 : Inhibitors

A way to test the different *FGFR3* inhibitors comprises transfecting cell lines so that they express the mutated forms of *FGFR3*, or wild type *FGFR3* or just the neomycin or hygromycin resistant gene under the control of a strong promoter, such as CMV, RSV, SV40 promoters. The tumorigenic properties of these cell lines can then be compared *in vitro* or *in vivo* in nude mice. The different inhibitors will be tested *in vitro* or *in vivo* using these different cell lines. Phosphorylation, proliferation or indirect effects of *FGFR3* such as calcium influx will be measured. Transgenic mice expressing in various epithelia the mutated *FGFR3* can thus be derived thereof. Those mice developing tumours are useful tools for testing the efficiency of candidate inhibiting drugs. Such transgenic animals fall also into the scope of the present invention.

20 Example 3 : *FGFR3* mutations in Ta, T1 tumours in bladder cancer.

Bladder cancer is a disease with a spectrum of forms and is highly unpredictable. At the time of initial diagnosis, approximately 80% of patients present with a superficial tumour. Superficial bladder cancers include carcinoma *in situ* (Tis), Ta and T1 lesions (TNM classification). Ta/T1 lesions are mostly papillary urothelial carcinomas: Ta lesions do not invade the basement membrane, whereas T1 lesions invade the lamina propria, but do not invade the detrusor muscle of the bladder wall. Carcinoma *in situ* are flat, cytologically high-grade carcinomas, confined to the urothelium. Primary isolated carcinoma *in situ* is a very rare entity and is more commonly associated with Ta/T1 lesions. Despite transurethral resection alone or combined with adjuvant intravesical therapies, more than one half of patients with Ta/T1 tumours suffer recurrences. In most cases, recurrences are also superficial, but about 5% of Ta and 30-50% of T1 tumours progress in an unpredictable manner to muscle invasion with a high risk of development of metastases and death from bladder cancer.

35 The management of superficial bladder cancer is based on clinicopathological parameters. Three groups of tumours can be defined. of low,

intermediate and high risk, according to their potential for recurrence and progression. This classification is used to recommend adjuvant intravesical therapies and bladder monitoring, but it is not a sufficiently sensitive discriminant for use in determining the appropriate treatment and mode of surveillance for a given patient. Although Bacille Calmette-Guérin (BCG) therapy appeared to be the most effective regimen for the high-risk group, long-term results indicate that progression occurs in 40% by 10 years and in more than 50% by 15 years. For some researchers, these findings justified the use of up-front radical cystectomy in high-risk superficial urothelial carcinomas, despite the risk of overtreating a significant number of patients. Follow-up of Ta and T1 superficial bladder cancers constitutes most of the workload of urologists involved in the management of bladder cancer. The current strategy is based on frequent cystoscopic evaluations using a schedule that is largely empirical, without considering the individual characteristics of the tumour.

The limitations of the current management of bladder cancer demonstrate the need for prognostic markers, making possible the use of selective aggressive treatments for patients at high risk of progression while sparing low-risk patients from unnecessary procedures. A number of chromosomal loci and specific genes have been implicated in bladder tumorigenesis. Losses of all or part of chromosome 9 in many TaG1 tumours suggests that the inactivation of a gene or genes on chromosome 9 may be an early event in urothelial transformation. The prognostic significance of losses on chromosome 9 is unclear. Alterations of the *P53* and *RB* genes controlling the G1 cell cycle checkpoint have been clearly delineated and are associated with the aggressiveness of superficial and invasive bladder cancers. Despite these recent insights into the molecular mechanisms of bladder carcinoma progression, these markers have not yet had any impact on clinical practice.

The following assays have been performed to assess the reliability, as markers, of the FGFR3 mutations.

Material and method

30 Patients and tissue samples

Seventy four specimens of superficial Ta, T1 bladder carcinomas were obtained from 74 patients by transurethral resection performed at the Henri Mondor hospital, Créteil, France, from January 1988 to December 1998. Tumours were staged according to the TNM classification (1) and graded according to criteria recommended by the World Health Organisation (2). This series consisted of 25 pTa and 49 pT1 tumours, with 28 grade G1, 33 grade G2 and 13 grade G3 tumours. The 64 men and 10 women had a mean age of 64 years (range: 29 to 94 years). None of the patients had any detectable distant metastases at the time of transurethral resection. Patients were treated

by transurethral resection (TUR) alone (n=25), TUR followed by mitomycin C instillation (n=10) or TUR and BCG (n=39) according to the French Committee for Urologic Oncology (CCAFU) recommendations. There was no change in the policy for treating superficial bladder cancer during the study period. Progression was defined as the occurrence of a pT2 or higher stage or appearance of lymph node invasion or metastasis or death from cancer. Disease-specific survival curves were plotted using death from urothelial cancer as the endpoint. Follow-up was based on systematic cystoscopy and cytology, and imaging studies only when indicated. All outpatient visits and hospital admissions were recorded in a database from which the study data were calculated.

Tumour DNA was extracted from formalin-fixed and paraffin-embedded tissue or samples freshly frozen in liquid nitrogen (4). Normal DNA samples from peripheral blood were available for 27 patients.

15 *FGFR3* mutation analysis

Mutations in the *FGFR3* gene were detected by SSCP analysis. Exons 7, 10, 15 and 20 of the *FGFR3* gene were analysed because these exons harbour all the mutations previously identified in bladder carcinomas and thanatophoric dysplasia. All mutations detected by SSCP analysis were confirmed by direct bidirectional sequencing of tumour genomic DNA. Matched normal DNA, if available, was sequenced on both strands to demonstrate the somatic nature of these mutations.

Statistical methods

Associations between *FGFR3* mutation status and other data (sex, age, stage and grade) were tested using χ^2 and Student's t tests. Progression-free and disease-specific survival curves were plotted using Kaplan-Meier estimates. Survival distributions were compared using the log-rank test. Cox's proportional hazards regression model was used to test the effect of mutations, while simultaneously accounting for baseline patient and tumour characteristics. The influence of the covariates on the *FGFR3* mutation effect was assessed in multivariate analysis involving a forward stepwise procedure and a backward stepwise procedure, using the MPRL (maximum partial likelihood ratio) method. The limit to enter a term was 0.15 and the limit to remove a term was 0.10. Statistical analyses were performed using BMDP® and S-Plus® software.

35

Results

FGFR3 missense mutations were observed in 41 of the 74 (55%) Ta, T1 bladder tumours. The *FGFR3* mutations found are described in Table 2 below :

Table 2

Number of tumours (%)	Codon*	nt position*	Mutation	Predicted effect
5 (12%)	248	742	CGC -> TGC	Arg -> Cys
28 (68.5%)	249	746	TCC -> TGC	Ser -> Cys
5 (12%)	372	1,114	GGC -> TGC	Gly -> Cys
2 (5%)	375	1,124	TAT -> TGT	Tyr -> Cys
1 (2.5%)	652	1,954	AAG -> GAG	Lys -> Glu

* codon and mutated nucleotide (nt position) are numbered according to FGFR3-IIIb cDNA open reading frame. FGFR3-IIIb is the isoform expressed in epithelial cells.

5

S249C was the commonest mutation and was found in 16 of the 21 (76%) mutated Ta tumours and 12 of the 20 (60%) mutated T1 tumours. Matched constitutional DNA, available in 15 of the cases of tumour with mutations, contained wild-type sequences, demonstrating the somatic nature of these mutations.

10

The correlation between sex, age, stage, grade and *FGFR3* mutation status is given Table 3 :

Table 3

	<i>FGFR3</i> wild type	<i>FGFR3</i> mutant	p value (χ^2 or Student's t test)
Sex			
Male	29	35	
Female	4	6	0.9779
Age (years)			
mean	64.30	63.22	
range	[29.15-86.10]	[34.3-94.4]	0.7393
Stage			
Ta	4	21	
T1	29	20	0.001
Grade			
G1	7	21	
G2	14	19	
G3	12	1	0.0003

5 Statistically significant correlations were observed between *FGFR3* mutations and low stage (p=0.001) and low grade (p=0.0003), but not between these mutations and age or sex (Table 2).

With a median follow-up of 4.3 years (range: 6 months to 11 years), 3 patients progressed and one died in the mutated tumour group (n=41 patients) whereas ten patients progressed and eight died in the non-mutated tumour group (n=33 patients).

The median follow-up was 5.6 years (range: 7 months to 11 years) in the non-mutated group and 4.1 years (range: 6 months to 9 years) in the mutated group.

To examine *FGFR3* mutations as a marker of patient outcome, we calculated Kaplan-Meier progression-free survival and disease-specific survival probability curves for the two groups of patients and examined the differences using the log rank test. Progression-free and disease-specific survival indicated that *FGFR3* mutations were associated with a lower risk of progression ($p=0.014$) and longer survival ($p=0.007$) (Figure 3). We tested several variables (age, sex, stage, grade) but only stage was significantly associated with progression and survival in univariate analysis. If only T1 patients were analysed, the correlation was still significant for disease-specific survival ($p=0.03$) and close to significance for progression-free survival ($p=0.052$).

Multivariate analysis was used to determine whether the correlation between *FGFR3* mutation status and progression-free survival or disease-specific survival was independent of other outcome predictors. For progression-free survival, the following covariates were introduced into the Cox model: mutation, stage, grade and sex. For disease-specific survival, mutation and grade were the only covariates introduced into the model, as no disease-related deaths were observed among female or Ta patients. If *FGFR3* status was entered into the model, neither stage nor grade provided any additional prognostic value for tumour progression. In the analysis of disease-specific survival, *FGFR3* mutation was also the only covariate to be entered into the model, as grade did not provide any additional prognostic information. Relative risks and their 95% confidence intervals (CI) are shown in Table 4.

Table 4

	Progression		Disease-specific Survival	
	Relative Risk	95% CI	Relative Risk	95% CI
<i>FGFR3</i>				
Wild-type	1		1	
Mutant	0.23	(0.06; 0.83)	0.10	(0.01; 0.80)
Other variables do not significantly contribute to the model				

Forward and backward procedures both yielded the same model.

As shown by the above results, the FGFR3 activating mutations were frequent in bladder carcinomas.

All the carcinomas having a mutated receptor expressed said receptor at levels similar or above those observed with normal tissues. Immunohistochemical methods will then advantageously be used for revealing the receptor.

FGFR3 mutation detection in bladder carcinomas appears to be a good prognostic, giving then to the clinicians valuable means for treating and observing carcinomas, which represent a medical problem due to the high frequency of recurrences.

By using SSCP or PCR coupled to an enzymatic restriction S249C mutation specific (which represent 75% of the mutations) on patients having bladder carcinomas with S249C mutation, the mutation could be detected in urine in 60% of the cases.

Example 4: Detection of FGFR3 mutations in patients' urines

Genomic DNA is extracted from patients' urines and amplified by PCR, in the presence of ³²P- labelled dCTP, using standard methods. The following primers were used for detecting S249C mutation :

5'-CAG CAC CGC CGT CTG GTT GG-3' and 5'-AGT GGC GGT GGT GGT GAG GGA G-3'.

30 cycles of PCR are performed.

The amplification products are digested by *Cac8I*. An additional site is created by *FGFR3* mutation and a corresponding band is observed on an electrophoretic gel.

Similarly the following primers and enzymes can be used to detect :

R248C mutation :

Primers : 5'-TGT GCG TCA CTG TAC ACC TTG CAG-3' and 5'-AGT GGC GGT GGT GGT GAG GGA G-3'

Enzyme : *Bsi* HKA I

K652E mutation :

Primers : 5'-TGG TGA CCG AGG ACA ACG TGA TG-3' and 5'-AGG GTG TGG GAA GGC GGT GTT G-3'

Enzyme : *Bsm* A I

G372C mutation :

Primers : 5'-CCT CAA CGC CCA TGT CTT TTC AGC-3' and 5'-CTT GAG CGG GAA GCG GGA GAT CTT G-3'

Enzyme : *Pst* I

Y375C mutation :

Primers : 5'-CCT CAA CGC CCA TGT CTT TTC AGC-3' and 5'-CTT GAG CGG
GAA GCG GGA GAT CTT G-3'

5 Enzyme : *Bsg* I

References

- 5 1. Sobin LH, Fleming ID. TNM Classification of Malignant Tumors, fifth edition (1997). Union Internationale Contre le Cancer and the American Joint Committee on Cancer. *Cancer* 1997; **80**: 1803-4.
- 10 2. Epstein JI, Amin MB, Reuter VR, Mostofi FK. The World Health Organization/International Society of Urological Pathology consensus classification of urothelial (transitional cell) neoplasms of the urinary bladder. Bladder Consensus Conference Committee. *Am J Surg Pathol* 1998; **22**: 1435-48.
- 15 3. Rischmann P, Bittard H, Chopin D, et al. Tumeurs Urothéliales. *Prog Urol* 1998; **8**: 25-50.
4. Cappellen D, Gil Diez de Medina S, Chopin D, Thiery JP, Radvanyi F. Frequent loss of heterozygosity on chromosome 10q in muscle-invasive transitional cell carcinomas of the bladder. *Oncogene* 1997; **14**: 3059-66.
- 20 5. Cappellen D, De Oliveira C, Ricol D, Gil Diez de Medina S, Bourdin J, Sastre-Garau X, Chopin D, Thiery JP, Radvanyi F. Frequent activating mutations of FGFR3 in human bladder and cervix carcinomas. *Nature Genetics*, vol 23, sept. 1999.
- 25 6. Gossen M, Freundlieb S, Bender G, Muller G, Hillen W, Bujard H. Transcriptional activation by tetracyclines in mammalian cells. *Science* 1995 ; **268** : 1766-9.

CLAIMS

1/ A method for detecting carcinomas in a biological sample, comprising
5 identifying FGFR3 mutations.

2/ The method of claim 1, comprising screening for single nucleotide
mutation(s) in nucleic acids of the group comprising genomic DNA, RNA or cDNA.

10 3/ The method of claim 1, comprising screening for single mutation(s) in
proteins.

4/ The method of claim 1, comprising screening for mutations creating cysteine
residues in the extracellular or transmembrane domains of the receptor.

15 5/ The method of claim 1, comprising screening for mutations resulting in at
least one amino-acid substitution in the kinase domain of the receptor.

6/ The method of claim 5, comprising screening of activating mutation(s) of
20 FGFR3.

7/ The method of claim 6, comprising screening of activating mutation(s) of
FGFR3-IIIb.

25 8/ The method of claim 1, comprising screening for mutation(s) in the group
comprising exon 7, encoding the junction between immunoglobulin-like domains II and
III of FGFR3, exon 10, encoding the transmembrane domain, exon 15, encoding the
tyrosine kinase domain I, and the exon encoding the C-terminal part.

30 9/ The method of claim 1, comprising screening for missense mutations such as
implicated in thanatophoric dysplasia, NSC, achondroplasia, SADDAN, or
hypochondroplasia.

35 10/ The method of claim 9, wherein the mutations comprise R248C, S249C,
G372C, S373C, Y375C, K652E, K652M, J809G, J809C, J809R, J809L, P250R,
G377C, G382R, A393E, N542K.

11/ The method of claim 9, comprising screening R248C, S249C, G372C, K652E and Y375C mutations.

12/ The method of claim 1, wherein the biological sample is selected in the group comprising a tissue, bone marrow, or a body fluid.

13/ The method of claim 12, wherein said body fluid is selected in the group comprising blood, urine from a warm-blooded animal.

14/ The method of claim 13, wherein said body fluid is from a human.

15/ The method of claim 1 for detecting human bladder and cervix carcinomas.

16/ The method of claim 1, for detecting lung, breast, colon, skin cancers.

17/ The pharmaceutical preparations having an anti-proliferative effect on carcinoma cells comprising an effective amount of agent(s) which act by inhibition of FGFR3 DNA synthesis or by inhibition of its expression products.

18/ The pharmaceutical preparations of claim 17, comprising tyrosine kinase inhibitors specific for FGFR3.

19/ The pharmaceutical preparation of claim 18, comprising antibodies directed againstp FGFR3.

20/ The pharmaceutical preparations of claim 17, comprising antisens oligonucleotides directed against a wild type or mutated FGFR3 isoform.

FIGURE 1

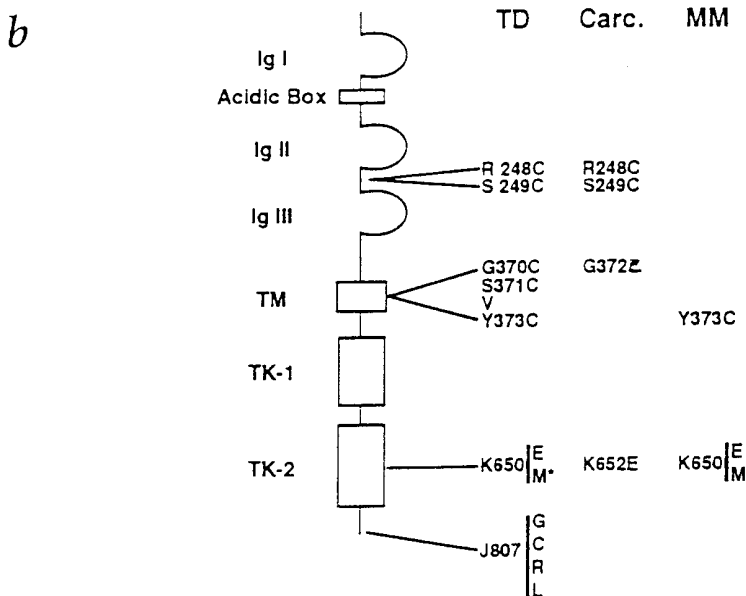
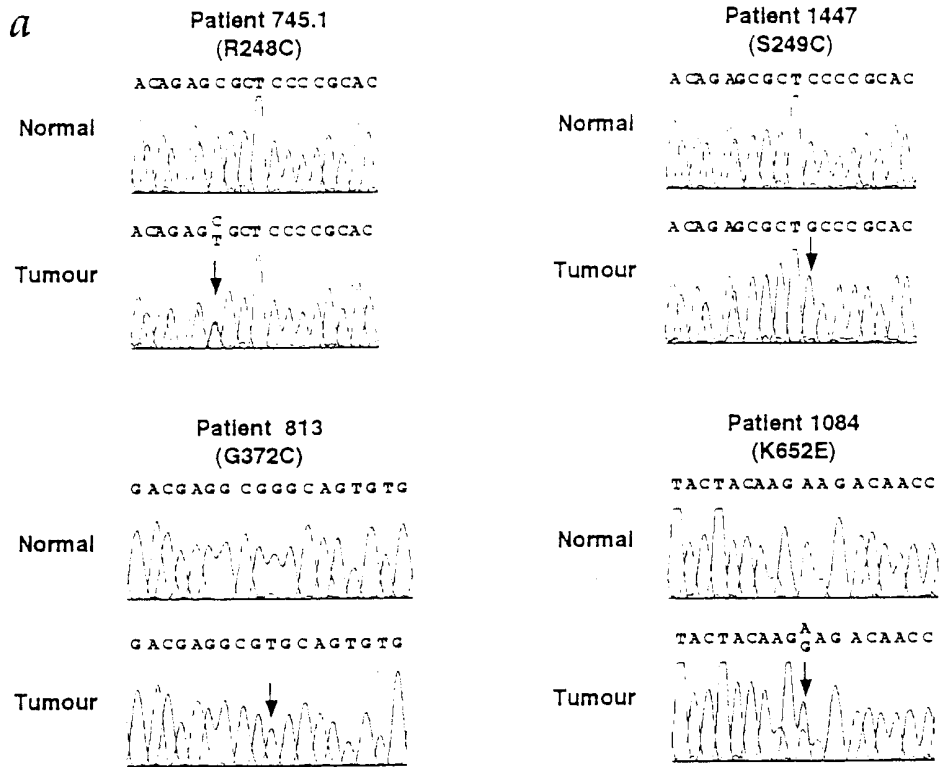

Figure 2A

Wild Type FGFR3-IIIb:

ATGGGCGCCCTGCCTGCGCCCTCGCGCTCTGCGTGGCCGTGGCCATCGTGGCCGGCGCCTCCTCGGAGTCTTGGGGAC
GGAGCAGCGCGTCTGTTGGGCGAGCGGCAGAAGTCCCCGGGCCAGAGCCCGCCAGCAGGAGCAGTTGGTCTTCGGCAGCG
GGGATGCTGTGGAGCTGAGCTGTCCCCGCCCGGGGTGGTCCCATGGGGCCACTGTCTGGGTCAAGGATGGCACAGGG
CTGGTGGCCCTCGGAGCGTGTCTGTTGGGGCCCCAGCGGCTGCAGGTGCTGAATGCCTCCCACGAGGACTCCGGGGCCTA
CAGCTGCCGGCAGCGGCTCACGCAGCGGCTACTGTGCCACTTCAGTGTGCGGGTGACAGACGCTCCATCCTCGGGAGATG
ACGAAGACGGGGAGGACGAGGCTGAGGACACAGGTGTGGACACAGGGGGCCCTTACTGGACACGGCCCGAGCGGATGGAC
AAGAAGCTGCTGGCCGTGCCGGCCGCCAACACCGTCCGCTTCCGCTGCCAGCCGCTGGCAACCCCACTCCCTCCATCTC
CTGGCTGAAGAACGGCAGGGAGTCCGCGGGCAGCACCAGTGGAGGCATCAAGCTGCCGCATCAGCAGTGGAGCCTGG
TCATGGAAAGCGTGGTGGCCCTCGGACCGCGGCAACTACACCTGCGTCTGGAGAACAAGTTTGGCAGCATCCGGCAGACG
TACACGCTGGACGTGCTGGAGCGCTCCCCGCACCGGCCCATCCTGCAGGGGGGCTGCCGGCCAACCAGACGGCGGTGCT
GGGCAGCGACGTGGAGTCCACTGCAAGGTGTACAGTGCAGCACAGCCCATCCAGTGGCTCAAGCACGTGGAGGTGA
ACGGCAGCAAGGTGGGCCCGGACGGCACACCCTACGTTACCGTGTCAAGTCTGGATCAGTGAAGTGTGGAGGCCGAC
GTGGCCTCCGCCTGGCCAATGTGTGGAGCGGGACGGGGGCGAGTACCTCTGTGAGCCACCAATTTTCATAGGCGTGGC
CGAGAAGGCCTTTTGGCTGAGCGTTCACGGGCCCCGAGCAGCCGAGGAGGAGCTGGTGGAGGCTGACGAGCGGGCAGTG
TGATGCAGGCATCCTCAGCTACGGGGTGGGCTTCTTCTGTTTTCATCCTGGTGGTGGCGGCTGTGACGCTCTGCCGCTG
CGCAGCCCCCAAGAAAGGCCTGGGCTCCCCACCGTGCACAAGATCTCCCGCTTCCCGCTCAAGCGACAGGTGTCCCT
GGAGTCCAACGCGTCCATGAGCTCCAACACACCACTGGTGGCAGTCCGCAAGGCTGTCTCAGGGGAGGGCCCCACGCTGG
CCAATGTCTCCGAGCTCGAGTGCCTGCCGACCCCAATGGGAGCTGTCTCGGGCCCGGCTGACCTGGGCAAGCCCTT
GGGGAGGGCTGCTTCGGCCAGGTGGTTCATGGCGGAGGCCATCGGCATGACAAGGACCAGGGCCCGCAAGCCTGTACCGT
AGCCGTGAAGATGCTGAAAGACGATGCCACTGACAAGGACCTGTCCGACCTGGTGTCTGAGATGGAGATGATGAAGATGA
TCGGGAAACACAAAACATCATCAACCTGCTGGGCGCCTGCACCGAGGGCGGGCCCTGTACGTGCTGGTGGAGTACCGG
GCCAAGGTAACCTGCGGGAGTTTCTGCGGGCGGGGCCCCGGGCTGGACTACTCCTTCGACACCTGCAAGCCGCC
CGAGGAGCAGCTCACCTCAAGGACCTGGTGTCTGTGCTACCAGGTGGCCCGGGGCATGGAGTACTTGGCCTCCCAGA
AGTGCATCCACAGGGACCTGGCTGCCCGCAATGTGCTGGTACCAGGACAACGTGATGAAGATCGCAGACTTCGGGCTG
GCCCCGGACGTGCACAACCTCGACTACTACAAGAAGACAACCAACGGCCGGCTGCCCGTGAAGTGGATGGCGCTGAGGC
CTTGTGTTGACCGAGTCTACACTACCAGAGTACGCTCTGGTCTTTGGGGTCTGCTCTGGGAGATCTTCACGCTGGGG
GCTCCCCGTACCCCGCATCCCTGTGGAGGAGCTCTTCAAGCTGCTGAAGGAGGGCCACCGCATGGACAAGCCCGCAAC
TGCACACACGACCTGTACATGATCATGCGGGAGTGTGGCATGCCGCGCCCTCCAGAGGCCACCTTCAAGCAGCTGGT
GGAGGACCTGGACCGTGTCTTACCGTACGCTCCACCGACGATACCTGGACCTGTCCGGCCCTTTTCGAGCAGTACTCCC
CGGTGGCCAGGACACCCCAAGCTCCAGCTCCTCAGGGACGACTCCGTGTTTGGCCACGACCTGCTCCCCCGGCCCA
CCCAGCAGTGGGGCTCGCGGACGTGA

Figure 2B

Mutant R248C FGFR3-IIIb:

ATGGGCGCCCCTGCCTGCGCCCTCGCGCTCTGCGTGGCCGTGGCCATCGTGGCCGGCGCCTCCTCGGAGTCCTTGGGGAC
GGAGCAGCGCGTCTGGGGCGAGCGGCAGAAAGTCCCGGGCCAGAGCCCGGCCAGCAGGAGCAGTTGGTCTTCGGCAGCG
GGGATGCTGTGGAGCTGAGCTGTCCCCGCCCGGGGGTGGTCCCATGGGGCCCACTGTCTGGGTCAAGGATGGCACAGGG
CTGGTGCCCTCGGAGCGTGTCTGGTGGGGCCCCAGCGGCTGCAGGTGCTGAATGCCTCCCACGAGGACTCCGGGGCCTA
CAGCTGCCGGCAGCGGCTCAGCAGCGCGTACTGTGCCACTTCAGTGTGCGGGTGACAGACGCTCCATCCTCGGGAGATG
ACGAAGACGGGAGGACGAGGCTGAGGACACAGGTGTGGACACAGGGGCCCCCTTACTGGACACGGCCCGAGCGGATGGAC
AAGAAGCTGCTGGCCGTGCCGGCCGCCAACACCGTCCGCTTCGCTGCCAGCCGCTGGCAACCCCACTCCCTCCATCTC
CTGGCTGAAGAAGCGCAGGGAGTTCGCGGCGAGCACCGCATTGGAGGCATCAAGCTGCGGCATCAGCAGTGGAGCCTGG
TCATGGAAAGCGTGGTGCCTCGGACCGCGGCAACTACACCTGCGTCTGGAGAACAAAGTTTGGCAGCATCCGGCAGACG
TACACGCTGGACGTGCTGGAGTGTCCCCGACCGGCCATCCTGCAGGCGGGGCTGCCGGCCAAACCAGACGGCGGTGCT
GGGACGCGAGTGGAGTTCCTGCAAGGTGTACAGTACGCGACAGCCCCACATCCAGTGGCTCAAGCACGTGGAGGTGA
ACGGCAGCAAGGTGGGCCCGGACGGCACACCCTACGTACCGTGTCAAGTCCCTGGATCAGTGAAGTGTGGAGGCCGAC
GTGCGCCTCCGCTGGCCATGTGTGGAGCGGGACGGGGCGAGTACCTCTGTCGAGCCACCAATTCATAGGGGTGGC
CGAGAAGCCCTTTTGGCTGAGCGTTCAGGGCCCCGAGCAGCCGAGGAGGAGCTGGTGGAGGCTGACGAGGCGGGCAGTG
TGTATGCAGGCATCCTCAGCTACGGGTGGGCTTCTTCCTGTTTATCCTGGTGGTGGCGGCTGTGACGCTCTGCCGCTG
CGCAGCCCCCAAGAAAGCCCTGGGCTCCCCACCGTGCACAAGATCTCCCGCTTCCCGCTCAAGCGACAGGTGTCCCT
GGAGTCCAACGCGTCCATGAGTCCAACACACCCTGGTGGCATCGCAAGGCTGTCCCTCAGGGGAGGGCCCCACGCTGG
CCAATGTCTCCGAGCTCGAGCTGCCTGCCGACCCCAATGGGAGTGTCTCGGGCCCGGCTGACCCCTGGCAAGCCCTT
GGGAGGGGCTGCTTCGGCCAGGTGGTTCATGGCGGAGGCCATCGGCATTGACAAGGACCGGGCCGCAAGCCTGTACCCT
AGCCGTGAAGATGCTGAAAGACGATGCCACTGACAAGGACCTGTCCGACCTGGTGTCTGAGATGGAGATGATGAAGATGA
TCGGGAAACACAAAAACATCATCAACTGCTGGGCGCCTGCACGCAGGGCGGGCCCCCTGTACGTGCTGGTGGAGTACGG
GCCAAGGGTAACCTGCGGGAGTTTCTGCGGGCGCGGGCGCCCCCGGGCCTGGACTACTCCTTCGACACCTGCAAGCCGCC
CGAGGAGCAGCTCACCTTCAAGGACCTGGTGTCTGTGCCTACCAGGTGGCCCGGGGCATGGAGTACTTGGCCTCCCAGA
AGTGCATCCACAGGGACCTGGCTGCCGCAATGTGCTGGTACCAGGAGGACAACGTGATGAAGATCGCAGACTTCGGGCTG
GCCCCGGACGTGCACAACCTCGACTACTACAAGAAGACAACCAACGGCCGGCTGCCCGTGAAGTGGATGGCGCCTGAGGC
CTTGTGTGACCGAGTCTACACTACCAGAGTACGCTCTGGTCTTTGGGGTCTGCTCTGGGAGATCTTACGCTGGGGG
GCTCCCCGTACCCCGGCATCCCTGTGGAGGAGCTCTTCAAGCTGCTGAAGGAGGGCCACCGCATGGACAAGCCCGCCAAC
TGACACACGACCTGTACATGATCATGCGGGAGTGTGGCATGCCGCGCCCTCCCAGAGGCCACCTTCAAGCAGCTGGT
GGAGGACCTGGACCGTGTCTTACCGTGACGTCCACCGACGAGTACCTGGACCTGTCCGGCGCCTTTCGAGCAGTACTCCC
CGGGTGGCCAGGACACCCCACTCCAGCTCCTCAGGGACGACTCCGTGTTGCCACGACCTGTGCCCCGGCCCCA
CCCAGCAGTGGGGGCTCGCGGACGTGA

Figure 2C

Mutant S249C FGFR3-IIIb:

ATGGGCGCCCTGCCTGCGCCCTCGCGCTCTGCGTGGCCGTGGCCATCGTGGCCGGCGCCTCCTCGGAGTCTTGGGGAC
GGAGCAGCGCTCGTGGGGCGAGCGGCAGAAGTCCCGGGCCAGAGCCCGGCCAGCAGGAGCAGTTGGTCTTCGGCAGCG
GGGATGCTGTGGAGCTGAGCTGTCCCCCGCCCGGGGGTGGTCCCATGGGGCCACTGTCTGGGTCAAGGATGGCACAGGG
CTGGTGGCCCTCGGAGCGTGTCTGGTGGGGCCCCAGCGGCTGCAGGTGCTGAATGCCTCCACGAGGACTCCGGGGCCTA
CAGCTGCCGGCAGCGGCTCACGCAGCGCTACTGTGCCACTTCAGTGTGCGGGTGACAGACGCTCCATCCTCGGGAGATG
ACGAAGACGGGAGGACGAGGCTGAGGACACAGGTGTGGACACAGGGGCCCTTACTGGACACGGCCCGAGCGGATGGAC
AAGAAGCTGTGGCCGTGCCGGCCGCAACACCGTCCGCTTCCGCTGCCAGCCGCTGGCAACCCCACTCCCTCCATCTC
CTGGTGAAGAACGGCAGGGAGTTCCGCGGGCAGCACCCGATTGGAGGCATCAAGCTGCGGCATCAGCAGTGGAGCCTGG
TCATGGAAAGCGTGGTGGCCCTCGGACCGCGGCAACTACACCTGCGTCTGGAGAACAAGTTTGGCAGCATCCGGCAGAGC
TACACGCTGGACGTGCTGGAGCGCTGCCCGCACCGGCCCATCCTGCAGGCGGGGCTGCCGGCAACCAGACGGCGGTGCT
GGCAGCGACGTGGAGTCCACTGCAAGGTGTACAGTGACGCACAGCCCCACATCCAGTGGCTCAAGCAGCTGGAGGTGA
ACGGCAGCAAGTGGGCCCGGACGGCACACCCTACGTTACCGTCTCAAGTCTGGATCAGTGAAGTGTGGAGGCCGAC
GTGCGCCTCCGCTGGCCAATGTGTGCGAGCGGGACGGGGCGAGTACCTCTGTGCGAGCCACCAATTTTCATAGGCGTGGC
CGAGAAGGCCTTTTGGCTGAGCGTTCACGGGCCCGAGCAGCCGAGGAGGAGCTGGTGGAGGCTGACGAGGCGGGCAGTG
TGTATGCAGGCATCCTCAGCTACGGGTGGGCTTCTTCTGTTTCATCCTGGTGGTGGCGGCTGTGACGCTCTGCCGCTG
CGCAGCCCCCAAGAAAGGCTGGGCTCCCCACCGTGCACAAGATCTCCCGCTTCCCGCTCAAGCGACAGGTGTCCCT
GGAGTCCAACGCGTCCATGAGCTCCAACACACCACTGGTGGCATCGCAAGGCTGTCTCAGGGGAGGGCCCCACGCTGG
CCAATGTCTCCGAGCTCGAGCTGCCTGCCGACCCCAATGGGAGTGTCTCGGGCCCGGCTGACCCTGGGCAAGCCCTT
GGGAGGGCTGCTTCGGCCAGGTGGTCAAGGGAGGCCATCGGCATTGACAAGGACCGGGCCGCAAGCCTGTACCGT
AGCCGTGAAGATGCTGAAAGACGATGCCACTGACAAGGACCTGTGCGACCTGGTGTCTGAGATGGAGATGATGAAGATGA
TCGGGAAACACAAAACATCATCAACCTGCTGGGCGCCTGCACGCAGGGCGGGCCCTGTACGTGCTGGTGGAGTACGG
GCCAAGGGTAACCTGCGGGAGTTTCTGCGGGCGCGGGCCCGGGCCCTGGACTACTCCTTCGACACCTGCAAGCCGCC
CGAGGAGCAGCTCACCTCAAGGACCTGGTGTCTGTGCCTACCAGGTGGCCCGGGGATGGAGTACTTGGCCTCCCAGA
AGTGCATCCACAGGGACCTGGCTGCCGCAATGTGCTGGTGACCAGGACAACGTGATGAAGATCGCAGACTTCGGGCTG
GCCCCGGACGTGCACAACCTCGACTACTACAAGAAGACAACCAACGGCCGGCTGCCCGTGAAGTGGATGGCGCTGAGGC
CTTGTGTTGACCGAGTCTACACTCACCGAGTGACGTCTGGTCTTTGGGGTCTGCTCTGGGAGATCTTACGCTGGGG
GCTCCCCGTACCCCGGATCCCTGTGGAGGAGCTCTCAAGCTGCTGAAGGAGGGCCACCGCATGGACAAGCCCGCCAAC
TGCACACACGACCTGTACATGATCATGCGGGAGTGTGGCATGCCGCGCCCTCCAGAGGCCACCTTCAAGCAGCTGGT
GGAGGACCTGGACCGTGTCTTACCCTGACGTCCACCGACGAGTACCTGGACCTGTGCGGCGCCTTTCGAGCAGTACTCC
CGGGTGGCCAGGACACCCCGAGCTCCTCAGGGGACGACTCCGTGTTTGGCCACGACCTGCTGCCCCGGCCCCA
CCCAGCAGTGGGGGCTCGCGGACGTGA

Figure 2D

Mutant G372C FGFR3-IIIb:

ATGGGCGCCCCCTGCCTGCGCCCTCGCGCTCTGCGTGGCCGTGGCCATCGTGGCCGGCGCCTCCTCGGAGTCCTTGGGGAC
GGAGCAGCGCGTCTGTGGGCGAGCGGCAGAAGTCCCGGGGCCAGAGCCCGGCCAGCAGGAGCAGTTGGTCTTCGGCAGCG
GGGATGCTGTGGAGCTGAGCTGTCCCCCGCCGGGGTGGTCCCATGGGGCCACTGTCTGGGTCAAGGATGGCACAGGG
CTGGTGCCTCGGAGCGTGTCTGGTGGGGCCCCAGCGGCTGCAGGTGCTGAATGCCTCCCACGAGGACTCCGGGGCCTA
CAGCTGCCGGCAGCGGCTCACGCAGCGCTACTGTGCCACTTCAGTGTGCGGGTGACAGACGCTCCATCCTCGGGAGATG
ACGAAGACGGGGAGGACGAGGCTGAGGACACAGGTGTGGACACAGGGGCCCTTACTGGACACGGCCCGAGCGGATGGAC
AAGAAGCTGCTGGCCGTGCCGGCCCAACACCGTCCGCTTCCGCTGCCAGCCGCTGGCAACCCCACTCCCTCCATCTC
CTGGCTGAAGAACGGCAGGGAGTTCCCGCGGCGAGCACCGCATTGGAGGCATCAAGCTGCGGGCATCAGCAGTGGAGCCTGG
TCATGGAAAGCGTGGTGCCTCGGACCGCGCAACTACACTGCGTCTGGAGAACAAGTTTGGCAGCATCCGGCAGACG
TACACGCTGGAGCTGCTGGAGCGTCCCCGCACCGGCCATCCTGCAGGGGGGGTCCCGGCCAACAGACGGCGGTGCT
GGGCAGCGACGTGGAGTTCCTGCAAGGTGTACAGTGACGCACAGCCCCACATCCAGTGGCTCAAGCACGTGGAGGTGA
ACGGCAGCAAGTGGGCCCCGACGGCACACCTACGTTACCGTGTCAAGTCTGGATCAGTGAGAGTGTGGAGGCCGAC
GTGGCCCTCCGCTGGCCAATGTGTGCGAGCGGGACGGGGCGAGTACCTCTGTGAGCCACCAATTTTATAGGCGTGGC
CGAGAAGGCCTTTTGGCTGAGCGTTCACGGGCCCCGAGCAGCCGAGGAGGAGCTGGTGGAGGCTGACGAGGCGTGCAGTG
TGTATGCAGGCATCCTCAGCTACGGGGTGGGCTTCTTCTGTTTATCCTGGTGGTGGCGGCTGTGACGCTCTGCCGCTG
CGCAGCCCCCAAGAAAGGCCTGGGCTCCCCACCGTGCACAAGATCTCCCGCTTCCCGCTCAAGCGACAGGTGTCCCT
GGAGTCCAACCGCTCCATGAGCTCCAACACACCACTGGTGCATCGCAAGGCTGTCTCAGGGGAGGGCCCCACGCTGG
CCAATGTCTCCGAGCTCGAGCTGCCTGCCGACCCCAAATGGGAGTGTCTCGGGCCCCGGCTGACCTGGGCAAGCCCTT
GGGAGGGCTGCTTCGGCCAGGTGGTTCATGGCGGAGGCCATCGGCATTGACAAGGACCGGGCCGCCAAGCCTGTACCGT
AGCCGTGAAGATGCTGAAAGACGATGCCACTGACAAGGACCTGTGCGGACCTGGTGTCTGAGATGGAGATGATGAAGATGA
TCGGGAAACACAAAACATCATCAACCTGCTGGGCGCCTGCACGCAGGGCGGGCCCCCTGTACGTGCTGGTGGAGTACGG
GCCAAGGGTAACCTGCGGGAGTTTCTGCGGGCGCGGGCCCCCGGGCCTGGACTACTCCTTCGACACCTGCAAGCCGCC
CGAGGAGCAGCTCACCTTCAAGGACCTGGTGTCTGTGCCTACCAGGTGGCCCGGGGCATGGAGTACTTGGCCTCCCAGA
AGTGCATCCACAGGGACCTGGCTGCCCCGAATGTGCTGGTGAACGAGGACAACCTGATGAAGATCGCAGACTTCGGGCTG
GCCCCGGACGTGCACAACCTCGACTACTACAAGAAGACAACCAACGGCCGGCTGCCCGTGAAGTGGATGGCGCCTGAGGC
CTTGTGTTGACCGAGTCTACACTCACCAGAGTGACGTCTGGTCTTTGGGGTCTGCTCTGGGAGATCTTACGCTGGGG
GCTCCCCGTACCCCGGCATCCCTGTGGAGGAGCTCTCAAGCTGCTGAAGGAGGGCCACCGCATGGACAAGCCCCGCAAC
TGCACACACGACCTGTACATGATCATGCCGGAGTGTGGCATGCCGCGCCCTCCCAGAGGGCCCCACTTCAAGCAGCTGGT
GGAGGACCTGGACCGTGTCTTACCCTGACGTCCACCGACGAGTACCTGGACCTGTGGCGCCTTTGAGCAGTACTCCC
CGGGTGGCCAGGACACCCCCAGCTCCAGCTCCTCAGGGGACGACTCCGTGTTTGGCCACGACCTGCTGCCCCGGCCCCA
CCCAGCAGTGGGGGCTCGCGGACGTGA

Figure 2E

Mutant K652E FGFR3-IIIb:

ATGGGGCCCCCTGCCTGCGCCCTCGCGCTCTGCGTGGCCGTGGCCATCGTGGCCGGCCCTCCTCGGAGTCCTTGGGGAC
GGAGCAGCGCGTGGTGGGGCGAGCGGCAGAAGTCCCGGGCCAGAGCCCGGCCAGCAGGAGCAGTTGGTCTTCGGCAGCG
GGGATGCTGTGGAGCTGAGCTGTCCCCCGCCGGGGGTGGTCCCATGGGGCCACTGTCTGGGTCAAGGATGGCACAGGG
CTGGTGCCTCGGAGCGTGTCTGGTGGGGCCCCAGCGGCTGCAGGTGCTGAATGCCTCCCACGAGGACTCCGGGGCCTA
CAGCTGCCGGCAGCGGCTCACGCAGCGCTACTGTGCCACTTCAGTGTGCGGGTGACAGACGCTCCATCCTCGGGAGATG
ACGAAGACGGGGAGGACGAGGCTGAGGACACAGGTGTGGACACAGGGGCCCTTACTGGACACGGCCGAGCGGATGGAC
AAGAAGCTGCTGGCCGTGCCGGCCGCCAACACCGTCCGCTCCGCTGCCAGCCGCTGGCAACCCCACTCCCTCCATCTC
CTGGCTGAAGAACGGCAGGAGTTCGGCGCGGAGCACCGCATTGGAGGCATCAAGCTGCGGCATCAGCAGTGGAGCCTGG
TCATGGAAAGCGTGGTGGCCCTCGGACCGGGCAACTACACCTGCGTGGTGGAGAACAGTTTGGCAGCATCCGGCAGACG
TACACGCTGGACGTGCTGGAGCGCTCCCCGCACCGGCCATCCTGCAGCCGGGGTGGCCGGCAACCAGACGGCGGTGCT
GGCAGCGCAGTGGAGTTCACCTGCAAGGTGTACAGTACGCACACGCCCCACATCCAGTGGTCAAGCAGCTGGAGGTGA
ACGGCAGCAAGGTGGGCCCGGACGGCACACCCTACGTTACCGTGTCAAGTCCCTGGATCAGTGAAGTGTGGAGCCGAC
GTGGCCCTCCGCTGGCCAAATGTGTGGAGCGGGACGGGGCGAGTACCTCTGTGAGCCACCAATTTTCATAGGCGTGGC
CGAGAAGGCCTTTTGGCTGAGCGTTACGGGGCCCCGAGCAGCCGAGGAGGAGCTGGTGGAGGCTGACGAGGCGGGCAGTG
TGTATGCAGGCATCCTCAGCTACGGGGTGGGCTTCTTCTGTTTCATCCTGGTGGTGGCGGCTGTGACGCTCTGCCGCTG
CGCAGCCCCCAAGAAAGCCTGGGCTCCCCACCGTGCACAAGATCTCCCGCTTCCCGCTCAAGCGACAGGTGTCCCT
GGAGTCCAACCGCTCCATGAGCTCCAACACACCACTGGTGGCAGTGGCAAGGCTGTCTCAGGGGAGGGCCCCACGCTGG
CCAATGTCTCCGAGCTCGAGCTGCCTGCCACCCCAATGGGAGCTGTCTCGGGCCCGGCTGACCCTGGGCAAGCCCTT
GGGGAGGGCTGCTTCGGCCAGGTGGTTCATGGCGGAGGCCATCGGCATTGACAAGGACCGGGCCCGCAAGCCTGTCAACCGT
AGCCGTGAAGATGCTGAAAGACGATGCCACTGACAAGGACCTGTGCGACCTGGTGTCTGAGATGGAGATGATGAAGATGA
TCGGAAACACAAAAACATCATCAACCTGCTGGGCGCCTGCACGCAGGGCGGGCCCTGTACGTGCTGGTGGAGTACCGG
GCCAAGGTAACCTGCGGGAGTTTCTGCGGGCGGGCCCGGGCCCTGGACTACTCCTTCGACACCTGCAAGCCGCC
CGAGGAGCAGCTCACCTTCAAGGACCTGGTGTCTGTGCTACCAGTGGCCCGGGCATGGAGTACTTGGCCTCCCAGA
AGTGCATCCACAGGACCTGGCTGCCGCAATGTGCTGGTACCAGGACAACGTGATGAAGATCGCAGACTTCGGGCTG
GCCCGGGACGTGCACAACCTCGACTACTACAAGGAGACAACCAACGGCCGGCTGCCCGTGAAGTGGATGGCGCCTGAGG
CTTGTGTTGACCGAGTCTACACTCACCAGAGTACGCTCTGGTCTTTGGGGTCTGCTCTGGGAGATCTTACGCTGGGG
GCTCCCCGTACCCGGCATCCCTGTGGAGGAGCTCTTCAAGCTGCTGAAGGAGGGCCACCGCATGGACAAGCCCGCCAA
TGCACACACGACCTGTACATGATCATGCGGGAGTGTGGCATGCCGCGCCCTCCAGAGGCCACCTTCAAGCAGCTGGT
GGAGGACCTGGACCGTGTCTTACCCTGACGTCCACCGACGAGTACCTGGACCTGTGGCGCCTTTCGAGCAGTACTCCC
CGGGTGGCCAGGACACCCCGAGCTCCAGCTCCTCAGGGGACGACTCCGTGTTGCCACGACCTGCTGCCCCGGCCCA
CCCAGCAGTGGGGGCTCGCGGACGTGA

Figure 2F

Mutant S373C FGFR3-IIIB:

ATGGGCGCCCTGCCTGCGCCCTCGCGCTCTGCGTGGCCGTGGCCATCGTGGCCGGCGCCTCCTCGGAGTCTTGGGGAC
GGAGCAGCGCGTGTGGGGCGAGCGGCAGAAAGTCCCAGGGCCAGAGCCCGGCCAGCAGGAGCAGTTGGTCTTCGGCAGCG
GGGATGCTGTGGAGCTGAGCTGTCCCCCGCCCGGGGTGGTCCCATGGGGCCACTGTCTGGGTCAAGGATGGCACAGGG
CTGGTGCCTCGGAGCGTGTCTGGTGGGGCCCCAGCGGCTGCAGGTGCTGAATGCCTCCCACGAGGACTCCGGGGCCTA
CAGCTGCCGGCAGCGGCTCACGCAGCGCTACTGTGCCACTTCAGTGTGCGGGTGACAGACGCTCCATCCTCGGGAGATG
ACGAAGACGGGGAGGACGAGGCTGAGGACACAGGTGTGGACACAGGGGCCCTTACTGGACACGGGCCGAGCGGATGGAC
AAGAAGCTGCTGGCCGTGCCGGCCGCAACACCGTCCGCTTCCGCTGCCAGCCGCTGGCAACCCCACTCCCTCCATCTC
CTGGCTGAAGAACGGCAGGGAGTTCCGCGGGCAGCACCAGCATTTGGAGGCATCAAGCTGCGGCATCAGCAGTGGAGCCTGG
TCATGGAAGCGTGGTGCCTCGGACCGCGCAACTACACCTGCGTGTGGAGAACAAGTTTGGCAGCATCCGGCAGACG
TACACGCTGGACGTGCTGGAGCGCTCCCCGCAACCGGCCATCCTGCAGGGGGGCTGCCGGCAACCAGACGGCGGTGCT
GGGCAGCGACGTGGAGTCCACTGCAAGGTGTACAGTACGCACAGCCCCACATCCAGTGGCTCAAGCACGTGGAGGTGA
ACGGCAGCAAGGTGGGCCCGGACGGCACACCTACGTTACCGTGTCAAGTCCCTGGATCAGTGAGAGTGTGGAGGGCGAC
GTGCGCCTCCGCTGGCCAATGTGTGCGAGCGGGACGGGGCGAGTACCTCTGTGAGCCACCAATTTTCATAGGCGTGGC
CGAGAAGGCCTTTTGGCTGAGCGTTCACGGGCCCCGAGCAGCCGAGGAGGAGCTGGTGGAGGCTGACGAGGCGGGCTGTG
TGTATGCAGGCATCCTCAGCTACGGGGTGGGCTTCTTCTGTTTCATCCTGGTGGTGGCGGCTGTGACGCTCTGCCGCCTG
CGCAGCCCCCAAGAAAGGCTGGGCTCCCCACCCTGCACAAGATCTCCCGCTTCCGCTCAAGCGACAGGTGTCCCT
GGAGTCCAACGCGTCCATGAGCTCCAACACACCCTGGTGGCATCGCAAGGCTGTCTCAGGGGAGGGCCCCACGCTGG
CCAATGTCTCCGAGCTCGAGCTGCCTGCCAGCCCCAAATGGGAGCTGTCTCGGGCCCGGCTGACCTGGGCAAGCCCTT
GGGGAGGGCTGCTTCGGCCAGGTGGTTCATGGCGGAGGCCATCGGCATTGACAAGGACCGGGCCGCCAAGCCTGTACCGT
AGCCGTGAAGATGCTGAAAGACGATGCCACTGACAAGGACCTGTGCGACCTGGTGTCTGAGATGGAGATGATGAAGATGA
TCGGGAAACACAAAAACATCATCAACCTGCTGGGCGCCTGCACGCAGGGCGGGCCCTGTACGTGCTGGTGGAGTACGCG
GCCAAGGGTAACCTGCGGGAGTTTCTGCGGGCGCGGGCCCCCGGGCCTGGACTACTCCTTCGACACCTGCAAGCCGCC
CGAGGAGCAGCTCACCTTCAAGGACCTGGTGTCTGTGCTACCAGGTGGCCCGGGGCATGGAGTACTTGGCCTCCCAGA
AGTGCATCCACAGGGACCTGGCTGCCGCAATGTGCTGGTGACCGAGGACAACGTGATGAAGATCGCAGACTTCGGGCTG
GCCCCGGACGTGCACAACCTCGACTACTACAAGAAGACAACCAACGGCCGGCTGCCCGTGAAGTGGATGGCGCCTGAGGC
CTTGTGTTGACCGAGTCTACACTACCCAGAGTGACGTCTGGTCTTTGGGGTCTGCTCTGGGAGATCTTCACGCTGGGGG
GCTCCCCGTACCCCGCATCCCTGTGGAGGAGCTCTCAAGCTGCTGAAGGAGGGCCACCGCATGGACAAGCCCGCCAAC
TGCACACAGACCTGTACATGATCATGCGGGAGTGTGGCATGCCGCGCCCTCCAGAGGGCCACCTTCAAGCAGCTGGT
GGAGGACCTGGACCGTGTCTTACCGTGACGTCCACCGACGAGTACCTGGACCTGTGGCGCCTTTTCGAGCAGTACTCCC
CGGGTGGCCAGGACACCCCCAGCTCCAGCTCCTCAGGGACGACTCCGTGTTTGGCCAGACCTGCTGCCCCGGGCCCA
CCCAGCAGTGGGGGCTCGCGGACGTGA

Figure 2G

Mutant Y375C FGFR3-IIIb:

ATGGGCGCCCTGCCTGCGCCCTCGCGCTCTGCGTGGCCGTGGCCATCGTGGCCGGCGCCTCCTCGGAGTCCCTGGGGAC
GGAGCAGCGCGTCTGGGGCGAGCGGCAGAAGTCCCAGGGCCAGAGCCCGCCAGCAGGAGCAGTTGGTCTTCGGCAGCG
GGGATGCTGTGGAGCTGAGCTGTCCCCCGCCGGGGTGGTCCCATGGGGCCCACTGTCTGGGTCAAGGATGGCACAGGG
CTGGTGGCCCTCGGAGCGTGTCTGGTGGGGCCCCAGCGGCTGCAGGTGCTGAATGCTCCCACGAGGACTCCGGGGCCTA
CAGCTGCCCGCAGCGGCTCACGCAGCGGTACTGTGCCACTTCAGTGTGCGGGTGACAGACGCTCCATCCTCGGGAGATG
ACGAAGACGGGGAGGACGAGGCTGAGGACACAGGTGTGGACACAGGGGCCCTTACTGGACACGGCCCGAGCGGATGGAC
AAGAAGCTGCTGGCCGTGCCGGCCGCCAACACCGTCCGCTTCCGCTGCCAGCCGCTGGCAACCCCACTCCCTCCATCTC
CTGGCTGAAGAACGGCAGGGAGTTCCGCGGGCAGCACCCGATTGGAGGCATCAAGCTGCGGCATCAGCAGTGGAGCCTGG
TCATGGAAAGCGTGGTGCCTCGGACCGCGGCACTACACCTGCGTCTGGAGAACAAAGTTTGGCAGCATCCGGCAGACG
TACACGCTGGACGTGCTGGAGCGCTCCCGCACCGGCCATCCTGCAGGCAGGGCTGCCGCCAACCCAGACGGCGGTGCT
GGGCAGCGACGTGGAGTTCCACTGCAAGGTGTACAGTGACGCACAGCCCCACATCCAGTGGCTCAAGCACGTGGAGGTGA
ACGGCAGCAAGGTGGGCCCGGACGGCACACCCTACGTTACCGTGTCAAGTCTGGATCAGTGAAGTGTGGAGGCCGAC
GTGCGCCTCCGCTGGCCAATGTGTGCGAGCGGGACGGGGCGAGTACCTCTGTGAGCCACCAATTTTCATAGGCGTGGC
CGAGAAGGCCTTTTGGCTGAGCGTTCACGGGCCCGAGCAGCCGAGGAGGCTGGTGGAGGCTGACGAGGCGGGCAGTG
TGTGTGACGGCATCCTCAGCTACGGGGTGGGCTTCTTCTGTTTCATCCTGGTGGTGGCGGCTGTGACGCTCTGCCGCTG
CGCAGCCCCCAAGAAAGGCCTGGGCTCCCCACCGTGCACAAGATCTCCGCTTCCCGCTCAAGCGACAGGTGTCCCT
GGAGTCCAACCGCTCCATGAGCTCCAACACACCCTGGTGCATCGCAAGGCTGTCTCAGGGGAGGGCCCCACGCTGG
CCAATGTCTCCGAGCTCGAGCTGCCTGCCGACCCCAATGGGAGCTGTCTCGGGCCCGGCTGACCCCTGGGCAAGCCCTT
GGGGAGGGCTGCTTCGGCCAGGTGGTTCATGGCGGAGGCCATCGGCATTGACAAGGACCGGGCCGCCAAGCCTGTACCCGT
AGCCGTGAAGATGCTGAAAGACGATGCCACTGACAAGGACCTGTGCGACCTGGTGTCTGAGATGGAGATGATGAAGATGA
TCGGGAAACACAAAAACATCATCAACCTGCTGGGCGCCTGCACGCAGGGCGGGCCCTGTACGTGCTGGTGGAGTACGCG
GCCAAGGGTAACCTGCGGGAGTTTCTGCGGGCGCGGGCCCGGGCCTGGACTACTCCTTCGACACCTGCAAGCCGCC
CGAGGAGCAGCTCACCTCAAGGACCTGGTGTCTGTGCTACCAGGTGGCCGGGGCATGGAGTACTTGGCCTCCCGA
AGTGATCCACAGGGACCTGGCTGCCCACAATGTGCTGGTACCAGGAGGACAACGTGATGAAGATCGCAGACTTCGGGCTG
GCCCCGGACGTGCACAACCTCGACTACTACAAGAAGACAACCAACGGCCGGCTGCCCGTGAAGTGGATGGCGCCTGAGGC
CTTGTGTTGACCGAGTCTACACTCACCGAGTGTGCTGCTGGTCTTTGGGGTCTGCTCTGGGAGATCTTCAGCTGGGG
GCTCCCCGTACCCCGGCATCCCTGTGGAGGAGCTCTCAAGCTGCTGAAGGAGGGCCACCGCATGGACAAGCCCGCCAAC
TGCACACACGACCTGTACATGATCATGCGGGAGTGTGGCATGCCGCGCCCTCCAGAGGGCCACCTTCAAGCAGCTGGT
GGAGGACCTGGACCGTGTCTTACCGTGACGTCCACCGACGAGTACCTGGACCTGTGCGGCGCCTTTCGAGCAGTACTCCC
CGGGTGGCCAGGACACCCCAAGCTCCAGCTCCTCAGGGGACGACTCCGTGTTTGCCCACGACCTGCTGCCCCGGCCCA
CCCAGCAGTGGGGGCTCGCGGACGTGA

9/22

Figure 2H

Mutant K652M FGFR3-IIIb:

ATGGGCGCCCCTGCCTGCGCCCTCGCGCTCTGCGTGGCCGTGGCCATCGTGGCCGGCGCCCTCCTCGGAGTCCTTGGGGAC
GGAGCAGCGCGTCTGTGGGGCGAGCGGCAGAAAGTCCCGGGCCAGAGCCCGGCCAGCAGGAGCAGTGGTCTTCGGCAGCG
GGGATGCTGTGGAGCTGAGCTGTCCCCCGCCGGGGGTGGTCCCATGGGGCCACTGTCTGGGTCAAGGATGGCACAGGG
CTGGTGCCCTCGGAGCGTGTCTGGTGGGGCCCCAGCGGCTGCAGGTGCTGAATGCCTCCCACGAGGACTCCGGGGCCTA
CAGCTGCCGGCAGCGGCTCACGCAGCGCTACTGTGCCACTTCAGTGTGCGGGTGACAGACGCTCCATCCTCGGGAGATG
ACGAAGACGGGGAGGACGAGGCTGAGGACACAGGTGTGGACACAGGGGGCCCTTACTGGACACGGCCCGAGCGGATGGAC
AAGAAGCTGCTGGCCGTGCCGGCCGCCAACACCGTCCGCTCCGCTGCCAGCCGCTGGCAACCCCACTCCCTCCATCTC
CTGGCTGAAGAACGGCAGGGAGTTCCCGCGGCGAGCACCGCATTGGAGGCATCAAGCTGCGGCATCAGCAGTGGAGCCTGG
TCATGGAAAGCGTGGTGCCTCGGACCCGCGCAACTACACCTGCGTCTGGAGAACAAGTTTGGCAGCATCCGGCAGACG
TACACGCTGGACGTGCTGGAGCGCTCCCCGCAACCGGCCATCCTGCAGGCGGGGCTGCCGGCCAACCCAGACGGCGGTGCT
GGGCAGCGACGTGGAGTTCCTGCAAGGTGTACAGTGACGCACAGCCCCACATCCAGTGGCTCAAGCACGTGGAGGTGA
ACGGCAGCAAGGTGGGCCCCGACGGCACACCTACGTTACCGTGTCAAGTCTGGATCAGTGAGAGTGTGGAGGCCGAC
GTGCGCCTCCGCTGGCCAATGTGTGCGAGCGGGACGGGGCGAGTACCTCTGTGAGCCACCAATTTTCATAGGCGTGGC
CGAGAAGGCCTTTTGGCTGAGCGTTACGGGCCCCGAGCAGCCGAGGAGGAGCTGGTGGAGGCTGACGAGGCGGGCAGTG
TGTATGCAGGCATCCTCAGCTACGGGGTGGGCTTCTTCTGTTCATCCTGGTGGTGGCGGCTGTGACGCTCTGCCGCTG
CGCAGCCCCCAAGAAAGGCTGGGCTCCCCACCGTGCACAAGATCTCCCGCTTCCGCTCAAGCGACAGGTGTCCCT
GGAGTCCAACCGCTCCATGAGCTCCAACACACCACTGGTGCATCGCAAGGCTGTCTCAGGGGAGGGCCCCACGCTGG
CCAATGTCTCCGAGCTCGAGCTGCCTGCCGACCCCAATGGGAGCTGTCTCGGGCCCGGCTGACCTGGGCAAGCCCTT
GGGGAGGGCTGCTTCGGCCAGGTGGTTCATGGCGGAGGCCATCGGCATTGACAAGGACCGGGCCGCAAGCCTGTACCCT
AGCCGTGAAGATGCTGAAAGACGATGCCACTGACAAGGACCTGTGCGACCTGGTGTCTGAGATGGAGATGATGAAGATGA
TCGGGAAACACAAAACATCATCAACCTGCTGGGCGCCTGCACGCAGGGCGGGCCCTGTACGTGCTGGTGGAGTACGCG
GCCAAGGGTAACCTGCGGGAGTTTCTGCGGGCGCGGGCCCCCGGGCTGGACTACTCCTTCGACACCTGCAAGCCGCC
CGAGGAGCAGCTCACCTTCAAGGACCTGGTGTCTGTGCTTACCAGGTGGCCCGGGGCATGGAGTACTTGGCCTCCCAGA
AGTGCATCCACAGGGACCTGGCTGCCCGCAATGTGCTGGTGACCGAGGACAACGTGATGAAGATCGCAGACTTCGGGCTG
GCCCGGGACGTGCACAACCTCGACTACTACAAGATGACAACCAACGGCCGCTGCCGTGAAGTGGATGGCGCCTGAGGC
CTTGTGTTGACCGAGTCTACACTCACCAGAGTGACGTCTGGTCTTTGGGGTCTGCTCTGGGAGATCTTACGCTGGGG
GCTCCCCGTACCCCGGCATCCCTGTGGAGGAGCTCTTCAAGCTGCTGAAGGAGGGCCACCGCATGGACAAGCCCGCCAAC
TGCACACACGACCTGTACATGATCATGCGGGAGTGTGGCATGCCGCGCCCTCCCAGAGGCCACCTTCAAGCAGTGGT
GGAGGACCTGGACCGTGTCTTACCCTGACGTCCACCGACGAGTACCTGGACCTGTCCGCGCCTTTCGAGCAGTACTCCC
CGGGTGGCCAGGACACCCCACTCCAGCTCCTCAGGGGACGACTCCGTGTTGCCACGACCTGTGCCCGGGCCCCA
CCCAGCAGTGGGGGCTCGCGGACGTGA

10/22

Figure 2I

Mutant X809C FGFR3-IIIb:

ATGGGCGCCCTGCCTGCGCCCTCGCGCTCTGCGTGGCCGTGGCCATCGTGGCCGGCGCCTCCTCGGAGTCTTGGGGAC
GGAGCAGCGCGTCTGGGGCGAGCGGCAGAAGTCCCGGGCCAGAGCCCGCCAGCAGGAGCAGTTGGTCTTCGGCAGCG
GGGATGCTGTGGAGCTGAGCTGTCCCCGCCCCGGGGTGGTCCCATGGGGCCACTGTCTGGGTCAAGGATGGCACAGGG
CTGGTGGCCCTCGGAGCGTGTCTGGTGGGGCCCCAGCGGGCTGCAGGTGCTGAATGCCTCCACGAGGACTCCGGGGCCTA
CAGCTGCCGGCAGCGGCTCACGCAGCGCTACTGTGCCACTTCAGTGTGCGGGTGACAGACGCTCCATCCTCGGGAGATG
ACGAAGACGGGGAGGACGAGGCTGAGGACACAGGTGTGGACACAGGGGGCCCTTACTGGACACGGCCCGAGCGGATGGAC
AAGAAGCTGCTGGCCGTGCCGGCCGCCAACACCGTCCGCTTCCGCTGCCAGCCGCTGGCAACCCCACTCCCTCCATCTC
CTGGGTGAAGAACGGCAGGGAGTCCCGCGGCGAGCACCGCATTGGAGGCATCAAGCTGCGGCATCAGCAGTGGAGCCTGG
TCATGGAAAGCGTGGTGCCTCGGACCGCGGCACTACACCTGCGTCTGGAGAACAAGTTTGGCAGCATCCGGCAGACG
TACACGCTGGACGTGCTGGAGCGCTCCCCGCACCGGCCCATCCTGCAGGCGGGGCTGCCGCCAACAGACGGCGGTGCT
GGGCAGCGACGTGGAGTCCACTGCAAGGTGTACAGTGACGCACAGCCCCACATCCAGTGGCTCAAGCAGCTGGAGGTGA
ACGGCAGCAAGGTGGGCCCGGACGGCACACCCTACGTTACCGTGCTCAAGTCTGGATCAGTGAGAGTGTGGAGGCCGAC
GTGGCCTCCGCCTGGCCAATGTGTCGGAGCGGACGGGGGCGAGTACCTCTGTGAGCCACCAATTTTCATAGGCGTGGC
CGAGAAGGCCTTTTGGCTGAGCGTTCACGGGCCCCGAGCAGCCGAGGAGGAGCTGGTGGAGGCTGACGAGGCGGGCAGTG
TGTATGCAGGCATCCTCAGCTACGGGGTGGGCTTCTTCTGTTCATCCTGGTGGTGGCGGCTGTGACGCTCTGCCGCCTG
CGCAGCCCCCCCCAAGAAAGGCCTGGGCTCCCCACCGTGCACAAGATCTCCCGCTTCCCGCTCAAGCGACAGGTGTCCCT
GGAGTCCAACGCTCCATGAGCTCCAACACACCACTGGTGGCATCGCAAGGCTGTCTCAGGGGAGGGCCCCACGCTGG
CCATGTCTCCGAGCTCGAGCTGCCTGCCGACCCCAAATGGGAGCTGTCTCGGGCCCGGCTGACCCTGGGCAAGCCCCCTT
GGGGAGGGCTGCTTCGGCCAGGTGGTTCATGGCGGAGGCCATCGGCATTGACAAGGACCGGGCCGCCAAGCCTGTCACCGT
AGCCGTGAAGATGCTGAAAGACGATGCCACTGACAAGGACCTGTCCGACCTGGTGTCTGAGATGGAGATGATGAAGATGA
TCGGGAAACACAAAAACATCATCAACCTGCTGGGCGCCTGCACGCAGGGCGGGCCCCCTGTACGTGCTGGTGGAGTACGCG
GCCAAGGGTAACCTGCGGGAGTTTCTGCGGGCGCGGCCGCCCGGGCCCTGGACTACTCCTTCGACACCTGCAAGCCGCC
CGAGGAGCAGCTCACCTTCAAGGACCTGGTGTCTGTGCTACCAGGTGGCCCGGGGCATGGAGTACTTGGCCTCCCAGA
AGTGCATCCACAGGGACCTGGCTGCCCGCAATGTGCTGGTACCAGGACACACGTGATGAAGATCGCAGACTTCGGGCTG
GCCCCGGACGTGCACAACCTCGACTACTACAAGAAGACAACCAACGGCCGGCTGCCCGTGAAGTGGATGGCGCCTGAGGC
CTTGTGTTGACCGAGTCTACACTACCAGAGTGACGTCTGGTCTTGGGGTCTGCTCTGGGAGATCTTCACGCTGGGGG
GCTCCCCGTACCCCGGCATCCCTGTGGAGGAGCTCTTCAAGCTGCTGAAGGAGGGCCACCGCATGGACAAGCCCGCCAAC
TGACACACGACCTGTACATGATCATGCGGGAGTGTGGCATGCCGCGCCCTCCAGAGGGCCACCTTCAAGCAGCTGGT
GGAGGACCTGGACCGTGTCTTACCCTGACGTCCACCGACGAGTACCTGGACCTGTCCGGCCCTTTTCGAGCAGTACTCC
CGGGTGGCCAGGACACCCCAAGCTCCAGCTCCTCAGGGGACGACTCCGTGTTTGGCCACGACCTGCTGCCCGGGCCCA
CCCAGCAGTGGGGCTCGCGGACGTGC

11/22

Figure 2J Mutant 1

Mutant X809G FGFR3-IIIb:

ATGGGCGCCCCTGCCTGCGCCCTCGCGCTCTGGGTGGCCGTGGCCATCGTGGCCGGCGCCTCCTCGGAGTCCCTGGGGAC
GGAGCAGCGCGTCTGTGGGGCGAGCGGCAGAAAGTCCCGGGCCAGAGCCCGGCCAGCAGGAGCAGTTGGTCTTCGGCAGCG
GGGATGCTGTGGAGCTGAGCTGTCCCCGCCCGGGGGTGGTCCCATGGGGCCACTGTCTGGGTCAAGGATGGCACAGGG
CTGGTGCCTCGGAGCGTGTCCCTGGTGGGGCCCCAGCGGCTGCAGGTGCTGAATGCCTCCCACGAGGACTCCGGGGCCTA
CAGCTGCCGGCAGCGGCTCACGCAGCGCTACTGTGCCACTTCAGTGTGCGGGTGACAGACGCTCCATCCTCGGGAGATG
ACGAAGACGGGGAGGACGAGGCTGAGGACACAGGTGTGGACACAGGGGGCCCTTACTGGACACGGCCCGAGCGGATGGAC
AAGAAGCTGCTGGCCGTGCCGGCCGCCAACACCGTCCGCTCCGCTGCCAGCCGCTGGCAACCCCACTCCCTCCATCTC
CTGGCTGAAGAACGGCAGGGAGTTCGCGGGCGAGCACCGCATTGGAGGCATCAAGCTGCGGCATCAGCAGTGGAGCCTGG
TCATGGAAAGCGTGGTGCCTCGGACCGCGGCAACTACACCTGCGTCTGGAGAACAAGTTTGGCAGCATCCGGCAGACG
TACACGCTGGACGTGCTGGAGCGCTCCCCGACCCGGCCCATCCTGCAGGCGGGGCTGCCGGCCAACCAGACGGCGGTGCT
GGGCAGCGACGTGGAGTCCACTGCAAGGTGTACAGTGACGCACAGCCACATCCAGTGGCTCAAGCACGTGGAGTGA
ACGGCAGCAAGGTGGGCCCGGACGGCACACCCTACGTTACCGTGTCAAGTCCCTGGATCAGTGAAGTGTGGAGGCCGAC
GTGCGCCTCCGCCTGGCCAATGTGTGCGAGCGGGACGGGGCGAGTACCTCTGTGAGCCACCAATTTTCATAGGCGTGGC
CGAGAAGGCCCTTTGGCTGAGCGTTCACGGGCCCGGAGCAGCCGAGGAGGAGCTGGTGGAGGCTGACGAGGCGGGCAGTG
TGTATGCAGGCATCCTCAGCTACGGGGTGGGCTTCTTCTGTTTCATCCTGGTGGTGGCGGCTGTGACGCTCTGCCGCCTG
CGCAGCCCCCAAGAAAGGCTGGGCTCCCCACCGTGCACAAGATCTCCCGCTTCCCGCTCAAGCGACAGGTGTCCCT
GGAGTCCAACCGTCCATGAGCTCCAACACACCCTGGTGGCATCGCAAGGCTGTCTCAGGGGAGGGCCCCACGCTGG
CCAATGTCTCCGAGCTCGAGCTGCCTGCCGACCCCAATGGGAGCTGTCTCGGGCCCGGCTGACCCTGGGCAAGCCCCTT
GGGGAGGGCTGCTTCGGCCAGTGGTTCATGGCGGAGGCCATCGGCATTGACAAGGACCGGGCCGCCAAGCCTGTACCCT
AGCCGTGAAGATGCTGAAAGACGATGCCACTGACAAGGACCTGTCCGACCTGGTGTCTGAGATGGAGATGATGAAGATGA
TCGGGAAACACAAAACATCATCAACCTGCTGGGCGCCTGCACGCAGGGCGGGCCCTGTACGTGCTGGTGGAGTACGG
GCCAAGGGTAACCTGCGGGAGTTTCTGCGGGCGCGGCGGCCCCCGGGCTGGACTACTCCTTCGACACCTGCAAGCCGCC
CGAGGAGCAGCTCACCTTCAAGGACCTGGTGTCTGTGCTACCAGTGGCCCGGGGCATGGAGTACTTGGCCTCCAGA
AGTGCATCCACAGGGACCTGGCTGCCCGCAATGTGCTGGTGACCCAGGACAACGTGATGAAGATCGCAGACTTCGGGCTG
GCCCGGGACGTGCACAACCTCGACTACTACAAGAAGACAACCAACGGCCGGCTGCCCGTGAAGTGGATGGCGCCTGAGGC
CTTGTGTTGACCGAGTCTACACTCACCAGAGTGACGTCTGGTCTTTGGGGTCTGCTCTGGGAGATCTTACGCTGGGG
GCTCCCCGTACCCCGGCATCCCTGTGGAGGAGCTCTTCAAGCTGCTGAAGGAGGGCCACCGCATGGACAAGCCCGCCAAC
TGACACACGACCTGTACATGATCATGCGGGAGTGCTGGCATGCCGCGCCCTCCAGAGGGCCACCTTCAAGCAGCTGGT
GGAGGACCTGGACCGTGTCTTACCCTGACGCTCCACCGACGAGTACCTGGACCTGTCCGGCCCTTTCGAGCAGTACTCC
CGGGTGGCCAGGACACCCCAAGCTCCAGCTCCTCAGGGGACGACTCCGTGTTTGGCCACGACCTGCTGCCCCGGCCCCA
CCAGCAGTGGGGGCTCGCGGACGGGA

12/22

Figure 2K Mutant 2

Mutant X809G FGFR3-IIIb:

ATGGGCGCCCTGCGCTGCGCCCTCGCGCTCTGCGTGGCCGTGGCCATCGTGGCCGGCCGCTCCTCGGAGTCCTTGGGGAC
GGAGCAGCGCGTCTGGGGCGAGCGGCAGAAAGTCCCGGGCCAGAGCCCGGCCAGCAGGAGCAGTTGGTCTTCGGCAGCG
GGGATGCTGTGGAGCTGAGCTGTCCCCGCCCCGGGGTGGTCCCATGGGGCCACTGTCTGGGTCAAGGATGGCACAGGG
CTGGTGCCTCGGAGCGTGTCTGGTGGGGCCCCAGCGGCTGCAGGTGCTGAATGCCTCCACAGGACTCCGGGGCCTA
CAGCTGCCCGGCAGCGGCTCACGCAGCGCTACTGTGCCACTTCAGTGTGCGGGTGACAGACGCTCCATCCTCGGGAGATG
ACGAAGACGGGAGGACGAGGCTGAGGACACAGGTGTGGACACAGGGGGCCCTTACTGGACACGGCCCCGAGCGGATGGAC
AAGAAGCTGCTGGCCGTGCCGGCCCAACACCGTCCGCTCCGCTGCCAGCCGCTGGCAACCCCACTCCCTCCATCTC
CTGGCTGAAGAACGGCAGGGAGTTCGCGGGCGAGCACCGCATTGGAGGCATCAAGCTGCGGCATCAGCAGTGGAGCCTGG
TCATGGAAAGCGTGGTGCCTCGGACCGCGGCAACTACACCTGCGTCTGGAGAACAAGTTTGGCAGCATCCGGCAGACG
TACACGCTGGACGTGCTGGAGCGCTCCCCGCAACCGGCCATCCTGCAGGCGGGGCTGCCGGCAACCAGACGGCGGTGCT
GGCAGCGACGTGGAGTTCCTACTGCAAGGTGTACAGTGACGCACAGCCCCACATCCAGTGGCTCAAGCACGTGGAGTGGA
ACGGCAGCAAGGTGGGCCCGGACGGCACACCCTACGTTACCGTGCTCAAGTCTGGATCAGTGAGAGTGTGGAGGCCGAC
GTGCGCCTCCGCTGGCCAATGTGTGCGAGCGGGACGGGGCGAGTACCTCTGTGAGCCACCAATTTATAGGCGTGGC
CGAGAAGGCCTTTTGGCTGAGCGTTCACGGGCCCCGAGCAGCCGAGGAGGAGCTGGTGGAGGCTGACGAGGCGGGCAGTG
TGTATGCAGGCATCCTCAGCTACGGGGTGGGCTTCTTCTGTTTCATCCTGGTGGTGGCGGCTGTGACGCTCTGCCGCTG
CGCAGCCCCCAAGAAAGGCTGGGCTCCCCACCGTGCACAAGATCTCCCGCTCCCGCTCAAGCGACAGGTGTCCCT
GGAGTCCAACGCGTCCATGAGCTCCAACACACCCTGGTGCATCGCAAGGCTGTCTCAGGGGAGGGCCCCACGCTGG
CCAATGTCTCCGAGCTCGAGCTGCCTGCCGACCCCAATGGGAGCTGTCTCGGGCCCGGCTGACCCTGGGCAAGCCCTT
GGGGAGGGCTGCTTCGGCCAGGTGGTTCATGGCGGAGGCCATCGGCATTGACAAGGACCGGGCCGCAAGCCTGTACCCT
AGCCGTGAAGATGCTGAAAGACGATGCCACTGACAAGGACCTGTCCGACCTGGTGTCTGAGATGGAGATGATGAAGATGA
TCGGGAAACACAAAACATCATCAACCTGCTGGGCGCCTGCACGCAGGGCGGGCCCTGTACGTGCTGGTGGAGTACGCG
GCCAAGGGTAACCTGCGGGAGTTTCTGCGGGCGCGGGCCCCGGGCTGGACTACTCCTTCGACACCTGCAAGCCGCC
CGAGGAGCAGCTCACCTCAAGGACCTGGTGTCTGTGCCTACCAGTGGCCCGGGGCATGGAGTACTTGGCCTCCAGA
AGTGCATCCACAGGGACCTGGCTGCCCGCAATGTGCTGGTGCACCGAGGACAACGTGATGAAGATCGCAGACTTCGGGCTG
GCCCCGGACGTGCACAACCTCGACTACTACAAGAAGACAACCAACGGCCGGCTGCCCGTGAAGTGGATGGCGCCTGAGGC
CTTGTTTGACCGAGTCTACACTCACCAGAGTGACGTCTGGTCTTTGGGGTCTGCTCTGGGAGATCTTCACGCTGGGGG
GCTCCCCGTACCCCGGCATCCCTGTGGAGGAGCTCTTCAAGCTGCTGAAGGAGGGCCACCGCATGGACAAGCCCGCCAAC
TGACACACGACCTGTACATGATCATGCGGGAGTGCTGGCATGCCGCGCCCTCCAGAGGGCCACCTTCAAGCAGCTGGT
GGAGGACCTGGACCGTGTCTTACCCTGACGTCCACCGACGAGTACCTGGACCTGTCCGGCCCTTTCGAGCAGTACTCCC
CGGGTGGCCAGGACACCCCAAGCTCCAGCTCCTCAGGGGACGACTCCGTGTTTGCCCCACGACCTGCTGCCCCGGCCCCA
CCCAGCAGTGGGGCTCGCGGACGAGA

Figure 2L Mutant 3

Mutant X809G FGFR3-IIIb:

ATGGGCGCCCTGCCTGCGCCCTCGCGCTCTGCGTGGCCGTGGCCATCGTGGCCGGCCCTCCTCGGAGTCCCTGGGGAC
GGAGCAGCGCGTCTGGGGCGAGCGGCAGAAGTCCCCGGCCAGAGCCCGCCAGCAGGAGCAGTTGGTCTTCGGCAGCG
GGGATGCTGTGGAGCTGAGCTGTCCCCGCCCCGGGGTGGTCCCATGGGGCCCACTGTCTGGGTCAAGGATGGCACAGGG
CTGGTGCCTCGGAGCGTGTCTGGTGGGGCCCCAGCGGCTGCAGGTGCTGAATGCCTCCCACGAGGACTCCGGGGCCTA
CAGCTGCCGGCAGCGGCTCAGCAGCGGCTACTGTGCCACTTCAGTGTGCGGGTGACAGACGCTCCATCCTCGGGAGATG
ACGAAGACGGGGAGGACGAGGCTGAGGACACAGGTGTGGACACAGGGGCCCTTACTGGACACGGCCCGAGCGGATGGAC
AAGAAGCTGCTGGCCGTGCCGGCCGCCAACCCGTCCGCTTCCGCTGCCAGCCGCTGGCAACCCCACTCCCTCCATCTC
CTGGCTGAAGAACGGCAGGGAGTTCCGGCGGAGCACCGCATTGGAGGCATCAAGCTGCGGCATCAGCAGTGGAGCCTGG
TCATGGAAAGCGTGGTGCCTCGGACCGCGGCAACTACACCTGCGTGGTGGAGAACAAAGTTTGGCAGCATCCGGCAGACG
TACACGCTGGACGTGCTGGAGCGCTCCCCGCACCCGGCCCATCCTGCAGGCGGGGCTGCCGGCAACCAGACGGCGGTGCT
GGGCAGCGACGTGGAGTTCCACTGCAAGGTGTACAGTGCACAGCCCCACATCCAGTGGCTCAAGCACGTGGAGGTGA
ACGGCAGCAAGGTGGGGCCGGACGGCACACCCTACGTTACCGTGTCAAGTCTGGATCAGTGAAGTGTGGAGGCCGAC
GTGCGCCTCCGCTGGCCAAATGTGTGCGAGCGGGACGGGGCGAGTACCTCTGTGAGCCCAACAAATTCATAGGCGTGGC
CGAGAAGGCCTTTTGGCTGAGCGTTCACGGGCCCGAGCAGCGGAGGAGGCTGGTGGAGGCTGACGAGGCGGGCAGTG
TGTATGCAGGCATCCTCAGCTACGGGTGGGCTTCTTCTGTTTCTCCTGGTGGTGGCGGCTGTGACGCTCTGCCGCTG
CGCAGCCCCCAAGAAAGGCCTGGGCTCCCCACCGTGCACAAGATCTCCCGCTTCCCGCTCAAGCGACAGGTGTCCCT
GGAGTCCAACGCGTCCATGAGCTCCAACACACCCTGGTGGCATCGCAAGGCTGTCTCAGGGGAGGGCCCCACGCTGG
CCAATGTCTCCGAGCTCGAGCTGCCTGCCGACCCAAATGGGAGCTGTCTCGGGCCCGGCTGACCCTGGGCAAGCCCCTT
GGGGAGGGTGTCTCGGCCAGGTGGTTCATGGCGGAGGCCATCGGCATTGACAAGGACCGGGCCCAAGCCTGTCACCGT
AGCCGTGAAGATGCTGAAAGACGATGCCACTGACAAGGACCTGTGCGACCTGGTGTCTGAGATGGAGATGATGAAGATGA
TCGGGAAACACAAAACATCATCAACCTGCTGGGCGCCTGCACGAGGGCGGGCCCTGTACGTGCTGGTGGAGTACGGC
GCCAAGGGTAACCTGGGGAGTTTCTGGGGCGCGGGCCCCCGGGCCTGGACTACTCCTTCGACACCTGCAAGCCGCC
CGAGGAGCAGCTCACCTTCAAGGACCTGGTGTCTGTGCCTACCAGGTGGCCCGGGGCATGGAGTACTTGGCCTCCCAGA
AGTGCATCCACAGGGACCTGGCTGCCCGCAATGTGCTGGTGAACGAGGACAACGTGATGAAGATCGCAGACTTCGGGCTG
CCCCGGGACGTGCACAACCTCGACTACTACAAGAAGACAACCAACGGCCGGCTGCCCGTGAAGTGGATGGCGCCTGAGG
CTTGTGTTGACCGAGTCTACACTCACCAGAGTGACGTCTGGTCTTTGGGGTCTGCTCTGGGAGATCTTACGCTGGGGG
GCTCCCCGTACCCCGGCATCCCTGTGGAGGAGCTCTTCAAGCTGCTGAAGGAGGGCCACCGCATGGACAAGCCCGCCAAC
TGCACACAGCCTGTACATGATCATGCGGGAGTGTGGCATGCCGCGCCCTCCAGAGGGCCACCTTCAAGCAGCTGGT
GGAGGACCTGGACCGTGTCTTACCGTGACGTCCACCGACGAGTACCTGGACCTGTGCGCGCCTTTCGAGCAGTACTCCC
CGGGTGGCCAGGACACCCCAAGCTCCAGCTCCTCAGGGGAGGACTCCGTGTTTGGCCACGACCTGCTGCCCGGGCCCCA
CCCAGCAGTGGGGCTCGCGGACGCGA

Figure 2M

Mutant X809L FGFR3-IIIb:

ATGGGCGCCCTGCCTGCGCCCTCGCGCTCTGCGTGGCCGTGGCCATCGTGGCCGGCGCCTCCTCGGAGTCTTGGGGAC
GGAGCAGCGCGTCTGTGGGGCGAGCGGCAGAAGTCCCAGGGCCAGAGCCCGGCCAGCAGGAGCAGTTGGTCTTCGGCAGCG
GGGATGCTGTGGAGCTGAGCTGTCCCCGCCCCGGGGTGGTCCCATGGGGCCACTGTCTGGGTCAAGGATGGCACAGGG
CTGGTGCCTCGGAGCGTGTCTGGTGGGGCCCCAGCGGCTGCAGGTGCTGAATGCCTCCCACGAGGACTCCGGGGCCTA
CAGTGCCCGGCGAGGGCTCACGCAGCGCTACTGTGCCACTTCAGTGTGCGGGTGACAGACGCTCCATCCTCGGGAGATG
ACGAAGACGGGGAGGACGAGGCTGAGGACACAGGTGTGGACACAGGGGCCCTTACTGGACACGGCCCGAGCGGATGGAC
AAGAAGCTGCTGGCCGTGCCGGCCGCCAACACCCGTCCGCTTCCGCTGCCACGCGCTGGCAACCCCACTCCCTCCATCTC
CTGGCTGAAGAACGGCAGGGAGTTCGCGGGCAGCACCAGTTCAGGAGCATCAAGCTGCGGCATCAGCAGTGGAGCCTGG
TCATGGAAAGCGTGGTGCCTCGGACCGCGGCACTACACCTGCGTCTGGGAGAACAAGTTGGCAGCATCCGGCAGACC
TACACGCTGGACGTGCTGGAGCGCTCCCCGACCGGCCCATCCTGCAGGCGGGGCTGCCGGCCAACAGACGGCGGTGCT
GGCAGCGACGTGGAGTTCCTGCAAGGTGTACAGTGCAGCACAGCCCCACATCCAGTGGCTCAAGCAGTGGAGGTGA
ACGGCAGCAAGGTGGGCCCCGACGGCACACCCTACGTTACCGTGTCAAGTCTGGATCAGTGAAGTGTGGAGGCCGAC
GTGCCCTCCGCCTGGCCAATGTGTGGAGCGGGACGGGGGGGAGTACCTCTGTGAGCCCAATTTTCATAGGCGTGGC
CGAGAAGGCCCTTTTGGCTGAGCGTTCAGGGCCCCGAGCAGCCGAGGAGGAGCTGGTGGAGGCTGACGAGGCGGGCAGTG
TGTATGCAGGCATCCTCAGCTACGGGGTGGGCTTCTTCTGTTCATCCTGGTGGTGGCGGCTGTGACGCTCTGCCGCTG
CGCAGCCCCCAAGAAAGGCCTGGGCTCCCCACCGTGCACAAGATCTCCCGCTTCCCGCTCAAGCGACAGGTGTCCCT
GGAGTCCAACGCGTCCATGAGCTCCAACACACCACTGGTGCATCGCAAGGCTGTCTCAGGGGAGGGCCCCACGCTGG
CCAATGTCTCGAGCTCGAGCTGCTGCCGACCCAAATGGGAGCTGTCTCGGGCCGGCTGACCCTGGGCAAGCCCCCTT
GGGAGGGCTGCTTCGGCCAGGTGGTTCATGGCGGAGGCCATCGGCATTGACAAGGACCGGGCCGCAAGCCTGTCCCGT
AGCCGTGAAGATGCTGAAAGACGATGCCACTGACAAGGACCTGTGCGACCTGGTGTCTGAGATGGAGATGATGAAGATGA
TCGGAAACACAAAACATCATCAACCTGCTGGGCGCCTGCACGCAGGGCGGGCCCCCTGTACGTGCTGGTGGAGTACGCG
GCCAAGGGTAACCTGCGGGAGTTTCTGCGGGCGCGGGCCCCCGGGCTGGACTACTCCTTCGACACCTGCAAGCCGCC
CGAGGAGCAGCTCACCTTCAAGGACCTGGTGTCTGTGCCTACCAGGTGGCCCCGGGGCATGGAGTACTTGGCCTCCCAGA
AGTGCATCCACAGGGACCTGGCTGCCGCAATGTGCTGGTACCAGGACAACGTGATGAAGATCGCAGACTTCGGGCTG
CCCCGGACGTGCACAACCTCGACTACTACAAGAAGACAACCAACGGCCGGCTGCCGTGAAGTGGATGGCGCCTGAGGC
CTTGTGTTGACCGAGTCTACACTCACCAGAGTGACGTCTGGTCTTTGGGGTCTGCTCTGGGAGATCTTACGCTGGGGG
GCTCCCCGTACCCGGCATCCCTGTGGAGGAGCTCTTCAAGCTGCTGAAGGAGGGCCACCGCATGGACAAGCCCGCCAAC
TGACACACGACCTGTACATGATCATGCGGGAGTGTGGCATGCCGCGCCCTCCCAGAGGCCACCTTCAAGCAGCTGGT
GGAGGACCTGGACCGTGTCTTACCGTGACGTCCACCGACGAGTACCTGGACCTGTGGCGCCTTTTCGAGCAGTACTCCC
CGGGTGGCCAGGACACCCCCAGCTCCAGCTCCTCAGGGACGACTCCGTGTTTGGCCACGACCTGCTCCCCCGGGCCCCA
CCAGCAGTGGGGGCTCGCGGACGTTA

Figure 2N Mutant 1

Mutant N542K FGFR3-IIIb:

ATGGGCGCCCTGCCTGCGCCCTCGCGCTCTGCGTGGCCGTGGCCATCGTGGCCGGCGCCTCCTCGGAGTCCTTGGGGAC
GGAGCAGCGCGTCTGTTGGGCGAGCGGCAGAAGTCCCAGGGCCAGAGCCCGCCAGCAGGAGCAGTTGGTCTTCGGCAGCG
GGGATGCTGTGGAGCTGAGCTGTCCCCGCCCGGGGTGGTCCCATGGGGCCCACTGTCTGGGTCAAGGATGGCACAGGG
CTGGTGCCTCTCGGAGCGTGTCTGGTGGGGCCCCAGCGGTGCAGGTGCTGAATGCCTCCCACGAGGACTCCGGGGCCTA
CAGCTGCCGGCAGCGGCTCACGCAGCGCTACTGTGCCACTTCAGTGTGCGGGTGACAGACGCTCCATCCTCGGGAGATG
ACGAAGACGGGGAGGACGAGGCTGAGGACACAGGTGTGGACACAGGGGCCCTTACTGGACACGGCCCCGAGCGGATGGAC
AAGAAGCTGCTGGCCGTGCCGGCCGCAACACCGTCCGCTTCCGCTGCCAGCCGCTGGCAACCCCACTCCCTCCATCTC
CTGGCTGAAGAACGGCAGGGAGTTCGCGGGCAGCACCGCATTGGAGGCATCAAGCTGCGGCATCAGCAGTGGAGCCTGG
TCATGGAAAGCGTGGTGCCTCGGACCGGGCAACTACACCTGCGTGTGGAGAACAAAGTTTGGCAGCATCCGGCAGACG
TACACGCTGGACGTGCTGGAGCGCTCCCCGCACCGGCCATCCTGCAGGCGGGGCTGCCGGCAACCAGACGGCGGTGCT
GGGCAGCGACGTGGAGTTCACCTGCAAGGTGTACAGTGACGCACAGCCCCACATCCAGTGGCTCAAGCACGTGGAGGTGA
ACGGCAGCAAGGTGGGCCCGGACGGCACACCCTACGTTACCGTGTCAAGTCCCTGGATCAGTGAGAGTGTGGAGGCCGAC
GTGCGCCTCCGCTGGCCAATGTGTGCGAGCGGGACGGGGCGAGTACCTCTGTGAGCCACCAATTTTCATAGGCGTGGC
CGAGAAGGCCTTTTGGCTGAGCGTTCACGGGCCCGGAGCAGCCGAGGAGGAGCTGGTGGAGGCTGACGAGGCGGGCAGTG
TGTATGCAGGCATCCTCAGCTACGGGGTGGGCTTCTTCTGTTCATCCTGGTGGTGGCGGCTGTGACGCTCTGCCCGCTG
CGCAGCCCCCAAGAAAGGCCTGGGCTCCCCACCGTGCACAAGATCTCCCGCTTCCCGCTCAAGCGACAGGTGTCCCT
GGAGTCCAACGCGTCCATGAGCTCCAACACACCACTGGTGCGCATCGCAAGGCTGTCTCAGGGGAGGGCCCCACGCTGG
CCAATGTCTCCGAGCTCGAGCTGCCTGCCGACCCCAATGGGAGCTGTCTCGGGCCCGGCTGACCCTGGGCAAGCCCTT
GGGGAGGGCTGCTTCGGCCAGGTGGTTCATGGCGGAGGCCATCGGCATTGACAAGGACCGGGCCGCAAGCCTGTCACCGT
AGCCGTGAAGATGCTGAAAGACGATGCCACTGACAAGGACCTGTCCGACCTGGTGTCTGAGATGGAGATGATGAAGATGA
TCGGGAAACACAAAACATCATCAAATGCTGGGCGCTGCACGCAGGGCGGGCCCTGTACGTGCTGGTGGAGTACGCG
GCCAAGGTAACCTGCGGGAGTTTCTGCGGGCGCGGCGGCCCCCGGGCCTGGACTACTCCTTCGACACCTGCAAGCCGCC
CGAGGAGCAGCTCACCTTCAAGGACCTGGTGTCTGTGCCTACCAGGTGGCCCGGGGCATGGAGTACTTGGCCTCCCAGA
AGTGCATCCACAGGACCTGGCTGCCCGCAATGTGCTGGTACCAGGAGACAACGTGATGAAGATCGCAGACTTCGGGCTG
GCCCCGGACGTGCACAACCTCGACTACTACAAGAAGACAACCAACGGCCGGCTGCCCGTGAAGTGGATGGCGCCTGAGGC
CTTGTGTTGACCGAGTCTACACTCACAGAGTGACGTCTGGTCTTTGGGGTCTGCTCTGGGAGATCTTACGCTGGGGG
GCTCCCCGTACCCCGCATCCCTGTGGAGGAGCTCTTCAAGCTGCTGAAGGAGGGCCACCGCATGGACAAGCCCGCCAAC
TGCACACACGACCTGTACATGATCATGCGGGAGTGTGGCATGCCGCGCCCTCCAGAGGCCACCTTCAAGCAGCTGGT
GGAGGACCTGGACCGTGTCTTACCGTGCAGTCCACCGACGAGTACCTGGACCTGTGCGGCGCTTTCGAGCAGTACTCCC
CGGGTGGCCAGGACACCCCAAGCTCCAGTCTCAGGGGACGACTCCGTGTTTGGCCACGACCTGCTGCCCCGGCCCCA
CCAGCAGTGGGGGCTCGCGGACGTGA

Figure 20 Mutant 2

Mutant N542K FGFR3-IIIb:

ATGGGCGCCCTGCCTGCGCCCTCGCGCTCTGCGTGGCCGTGGCCATCGTGGCCGGCGCCTCCTCGGAGTCCTTGGGGAC
 GGAGCAGCGCGTCTGTGGGGCGAGCGGCAGAAAGTCCCCGGGCCAGAGCCCGGCCAGCAGGAGCAGTTGGTCTTCGGCAGCG
 GGGATGCTGTGGAGCTGAGCTGTCCCCCGCCGGGGTGGTCCCATGGGGCCCACTGTCTGGGTCAAGGATGGCACAGGG
 CTGGTGCCTCGGAGCGTGTCTGGTGGGGCCCCAGCGGCTGCAGGTGCTGAATGCCTCCCACGAGGACTCCGGGGCCTA
 CAGCTGCCGGCAGCGGCTCACGCAGCGCTACTGTGCCACTTCAGTGTGCGGGTGACAGACGCTCCATCCTCGGGAGATG
 ACGAAGACGGGGAGGACGAGGCTGAGGACACAGGTGTGGACACAGGGGCCCTTACTGGACACGGCCCCGAGCGGATGGAC
 AAGAAGCTGCTGGCCGTGCCGGCCGCCAACACCCTCCGCTTCGGTGGCCAGCCGCTGGCAAACCCACTCCCTCCATCTC
 CTGGCTGAAGAACGGCAGGGAGTTCGGCGGCGAGCACCGCATTTGGAGGCATCAAGCTGCGGCATCAGCAGTGGAGCCTGG
 TCATGGAAAGCGTGGTGCCTCGGACCGGGCAACTACACCTGCGTCTGGAGAACAAGTTTGGCAGCATCCGGCAGACG
 TACACGCTGGACGTGCTGGAGCGCTCCCCGCACCGGCCATCCTGCAGGGGGGGCTGCCGGCCAACAGACGGCGGTGCT
 GGGCAGCGACGTGGAGTTCCTACTGCAAGGTGTACAGTGCAGCAGCCCCACATCCAGTGGCTCAAGCAGCTGGAGGTGA
 ACGGCAGCAAGGTGGGCCAATGTGTGCGAGCGGGACGGGGGGAGTACCTCTGTGAGCCACCAATTTTCATAGGCGTGGC
 GTGCCCTCCGCTGGCCAAATGTGTGCGAGCGGGACGGGGGGAGTACCTCTGTGAGCCACCAATTTTCATAGGCGTGGC
 CGAGAAGGCCTTTTGGCTGAGCGTTACCGGGCCCCGAGCAGCCGAGGAGGAGCTGGTGGAGGCTGACGAGGCGGGCAGTG
 TGTATGCAGGCATCCTCAGCTACGGGGTGGGCTTCTTCTGTTTCATCCTGGTGGTGGCGGCTGTGACGCTCTGCCGCTG
 CGCAGCCCCCAAGAAAGGCCTGGGCTCCCCACCCTGCACAAGATCTCCCGCTTCCCGCTCAAGCGACAGGTGTCCCT
 GGAGTCCAACGCGTCCATGAGCTCCAACACACCCTGGTGGCATCGCAAAGCTGTCTCAGGGGAGGGCCCCACGCTGG
 CCAATGTCTCCGAGCTCGAGCTGCCTGCCGACCCCAATGGGAGCTGTCTCGGGCCCGGCTGACCCTGGCAAGCCCTT
 GGGGAGGGCTGCTTCGGCCAGGTGGTCAATGGCGGAGGCCATCGGCATTGACPAAGGACCGGGCCGCCAAGCCTGTACCCT
 AGCCGTGAAGATGCTGAAAGACGATGCCACTGACAAGGACCTGTGCGACCTGGTGTCTGAGATGGAGATGATGAAGATGA
 TCGGGAAACACAAAACATCATCAAGCTGCTGGGCGCCTGCACGCAGGGCGGGCCCTGTACGTGCTGGTGGAGTACGGC
 GCCAAGGTAACCTGCGGGAGTTTCTGCGGGCGCGGGGCCCGGGCCTGGACTACTCCTTCGACACCTGCAAGCCGCC
 CGAGGAGCAGCTCACCTTCAAGGACCTGGTGTCTGTGCTTACCAGGTGGCCCGGGGCATGGAGTACTTGGCCTCCCAGA
 AGTGCATCCACAGGGACCTGGCTGCCCGCAATGTGCTGGTGAACGAGGACAACTGATGAAGATCGCAGACTTCGGGCTG
 GCCCGGACGTGCACAACCTCGACTACTACAAGAAGACAACCAACGGCCGGCTGCCCGTGAAGTGGATGGCGCCTGAGGC
 CTTGTTTGACCGAGTCTACACTCACCGAGTGACGTCTGGTCCCTTGGGGTCTGCTCTGGGAGATCTTCACGCTGGGGG
 GCTCCCCGTACCCCGGCATCCCTGTGGAGGAGCTCTTCAAGCTGCTGAAGGAGGGCCACCGCATGGACAAGCCCGCCAA
 TGACACACGACCTGTACATGATCATGCGGGAGTGTGGCATGCCGCGCCCTCCAGAGGGCCACCTTCAAGCAGCTGGT
 GGAGGACCTGGACCGTGTCTTACCCTGACGTCCACCGACGAGTACCTGGACCTGTGGCGCCTTTCGAGCAGTACTCCC
 CGGGTGGCCAGGACACCCCGAGCTCCAGCTCCTCAGGGGACGACTCCGTGTTTCCCACGACCTGCTGCCCGGGCCCA
 CCCAGCAGTGGGGCTCGCGGACGTGA

Figure 2P Mutant 1

Mutant G382R FGFR3-IIIb:

ATGGGGCCCCCTGCCTGCGCCCTCGCGCTCTGCGTGGCCCGTGGCCATCGTGGCCGGCCGCTCCTCGGAGTCCCTGGGGAC
GGAGCAGCCCGTCTGGGGCAGCGGCAGAAGTCCCGGGCCAGAGCCCGCCAGCAGGAGCAGTTGGTCTTCGGCAGCG
GGGATGCTGTGGAGCTGAGCTGTCCCCGCCCCGGGGTGGTCCCATGGGGCCCACTGTCTGGGTCAAGGATGGCACAGGG
CTGGTGCCCTCGGAGCGTGTCTGGTGGGGCCCCAGCGGCTGCAGGTGCTGAATGCCTCCCACGAGGACTCCGGGGCCTA
CAGCTGCCGGCAGCGGCTCACGCAGCGCTACTGTGCCACTTCAGTGTGCGGGTGACAGACGCTCCATCCTCGGGAGATG
ACGAAGACGGGGAGGACGAGGCTGAGGACACAGGTGTGGACACAGGGGCCCTTACTGGACACGGCCCGAGCGGATGGAC
AAGAAGCTGCTGGCCGTGCCGGCCGCAACACCGTCCGCTTCCGCTGCCAGCCGCTGGCAACCCCACTCCCTCCATCTC
CTGGCTGAAGAACGGCAGGGAGTTCCGCGGGCAGCACCCGATTGGAGGCATCAAGCTGCGGCATCAGCAGTGGAGCCTGG
TCATGGAAAGCGTGGTGGCCCTCGGACCGCGGCAACTACACCTGCGTCTGGAGAACAAGTTTGGCAGCATCCGGCAGACG
TACACGCTGGACGTGCTGGAGCGCTCCCCGACCGGCCCATCCTGCAGGCGGGGCTGCCGGCCAACCAGACGGCGGTGCT
GGCAGCGACGTGGAGTTCCTGCAAGGTGTACAGTGCACACAGCCCCACATCCAGTGGCTCAAGCACGTGGAGGTGA
ACGGCAGCAAGGTGGGCCCGGACGGCACACCCTACGTTACCGTGTCAAGTCTGGATCAGTGGAGGTGGAGGGCCGAC
GTGCGCCTCCGCTGGCCAATGTGTGCGAGCGGGACGGGGCCGAGTACCTCTGTGAGCCACCAATTTTCATAGGCGTGGC
CGAGAAGGCCTTTTGGCTGAGCGTTACGGGGCCCCGAGCAGCCGAGGAGGAGCTGGTGGAGGCTGACGAGGGCGGGCAGTG
TGATGCAGGCATCCTCAGCTACAGGGTGGGCTTCTTCTGTTTCACTCCTGGTGGTGGCGGCTGTGACGCTCTGCCGCTG
CGCAGCCCCCAAGAAAGGCCTGGGCTCCCCCACCCTGCACAAGATCTCCCGCTTCCCGCTCAAGCGACAGGTGTCCCT
GGAGTCCAACGCGTCCATGAGCTCCAACACACCCTGGTGGCAGTCCGCAAGGCTGTCTCAGGGGAGGGCCCCACGCTGG
CCAATGTCTCCGAGCTCGAGCTGCCTGCCGACCCCAATGGGAGCTGTCTCGGGCCCGGCTGACCCTGGGCAAGCCCCTT
GGGAGGGCTGCTTCGGCCAGGTGGTTCATGGCGGAGGCCATCGGCATTGACAAGGACCGGGCCGCAAGCCTGTACCCTG
AGCCGTGAAGATGCTGAAAGACGATGCCACTGACAAGGACCTGTCCGACCTGGTGTCTGAGATGGAGATGATGAAGATGA
TCGGGAAACACAAAACATCATCAACCTGCTGGGCGCCTGCACGCAGGGCGGGCCCCCTGTACGTGCTGGTGGAGTACGGC
GCCAAGGGTAACCTGCGGGAGTTTCTGCGGGCGCGGGCCCCCGGGCCTGGACTACTCCTTCGACACCTGCAAGCCGCC
CGAGGAGCAGCTCACCTTCAAGGACCTGGTGTCTGTGCCTACCAGGTGGCCCGGGGCATGGAGTACTTGGCCTCCCAGA
AGTGCATCCACAGGGACCTGGCTGCCCGCAATGTGCTGGTACCAGGACAACGTGATGAAGATCGCAGACTTCGGGCTG
GCCCCGGACGTGCACAACCTCGACTACTACAAGAAGACAACCAACGGCCGGCTGCCCGTGAAGTGGATGGCGCCTGAGGC
CTTGTTTGACCGAGTCTACACTCACAGAGTGACGTCTGGTCTTTGGGGTCTGCTCTGGGAGATCTTCACGCTGGGGG
GCTCCCCGTACCCCGGCATCCCTGTGGAGGAGCTCTTCAAGCTGCTGAAGGAGGGCCACCGCATGGACAAGCCCCCAAC
TGCACACACGACCTGTACATGATCATGCGGGAGTGTGGCATGCCGCGCCCTCCAGAGGCCACCTTCAAGCAGCTGGT
GGAGGACCTGGACCGTGTCTTACCCTGACGTCCACCGACGAGTACCTGGACCTGTGCGCGCCTTTCGAGCAGTACTCCC
CGGGTGGCCAGGACACCCCCAGCTCCAGCTCCTCAGGGGACGACTCCGTGTTTGGCCACGACCTGCTCCCCCGGGCCCA
CCCAGCAGTGGGGCTCGCGGACGTGA

Figure 2Q Mutant 2

□

□

Mutant G382R FGFR3-IIIb:

□

□

ATGGGCGCCCTGCCTGCGCCCTCGCGCTCTGCGTGGCCGTGGCCATCGTGGCCGGCGCCTCCTCGGAGTCCCTGGGGAC
GGAGCAGCGCGTTCGTGGGCGAGCGGCAGAAAGTCCCGGGCCAGAGCCCGCCAGCAGGAGCAGTTGGTCTTCGGCAGCG
GGGATGCTGTGGAGCTGAGCTGTCCCCGCGCGGGGTGGTCCCATGGGGCCACTGTCTGGGTCAAGGATGGCACAGGG
CTGGTGCCTCGGAGCGTGTCTGGTGGGGCCCCAGGGCTGCAGGTGCTGAATGCCTCCCACGAGGACTCCGGGGCCTA
CAGCTGCCGGCAGCGGCTCACGCAGCGCTACTGTGCCACTTCAGTGTGCGGGTGACAGACGCTCCATCCTCGGGAGATG
ACGAAGACGGGGAGGACGAGGCTGAGGACACAGGTGTGGACACAGGGGGCCCTTACTGGACACGGCCCCGAGCGGATGGAC
AAGAAGCTGCTGGCCGTGCCGGCCCAACCCGCTCCGCTCCGCTGCCAGCCGCTGGCAACCCCACTCCCTCCATCTC
CTGGCTGAAGAACGGCAGGGAGTTCCGCGGCGAGCACCCGATTGGAGGCATCAAGCTGCGGCATCAGCAGTGGAGCCTGG
TCATGGAAAGCGTGGTGCCTCGGACCGCGCAACTACACCTGCGTTCGTGGAGAACAAGTTTGGCAGCATCCGGCAGACG
TACAGCTGGACGTGCTGGAGCGCTCCCGCACCGGCCCATCCTGCAGGCGGGGCTGCCGGCAACCAGACGGCGGTGCT
GGGCAGCGACGTGGAGTTCCACTGCAAGGTGTACAGTGACGCACAGCCCCACATCCAGTGGCTCAAGCACGTGGAGGTGA
ACGGCAGCAAGGTGGGCCCCGACGGCACACCCTACGTTACCCTGCTCAAGTCCCTGGATCAGTGAGAGTGTGGAGGCCGAC
GTGGCCTCCGCCTGGCCAATGTGTCGGAGCGGGACGGGGGGGAGTACCTCTGTGAGCCACCAATTTTCATAGGCGTGGC
CGAGAAGGCCTTTTGGCTGAGCGTTCACGGGCCCCGAGCAGCCGAGGAGGCTGGTGGAGGCTGACGAGGCGGGCAGTG
TGTATGCAGGCATCCTCAGCTACCGGGTGGGCTTCTTCTGTTTCATCCTGGTGGTGGCGGCTGTGACGCTCTGCCGCTG
CGCAGCCCCCAAGAAAGGCCTGGGCTCCCCACCGTGCACAAGATCTCCCGCTTCCCGCTCAAGCGACAGGTGTCCCT
GGAGTCCAACGCTCCATGAGCTCCAACACACCCTGGTGGCATCGCAAGGCTGTCTCAGGGGAGGGCCCCACGCTGG
CCAATGTCTCCGAGCTCGAGCTGCCTGCCGACCCCAATGGGAGCTGTCTCGGGCCCCGCTGACCCTGGGCAAGCCCCTT
GGGAGGGCTGCTTCGGCCAGGTGGTTCATGGCGGAGGCCATCGGCATTGACAAGGACCGGGCCGCAAGCCTGTCACCGT
AGCCGTGAAGATGCTGAAAGACGATGCCACTGACAAGGACCTGTGCGACCTGGTGTCTGAGATGGAGATGATGAAGATGA
TCGGGAAACACAAAAACATCATCAACCTGCTGGCGCCTGCACGCAGGGCGGGCCCCCTGTACGTGCTGGTGGAGTACGG
GCCAAGGGTAACCTGCGGGAGTTTCTGCGGGCGCGGGCCCCCGGGCCTGGACTACTCCTTCGACACCTGCAAGCCGCC
CGAGGAGCAGCTCACCTTCAAGGACCTGGTGTCTGTGCCTACCAGGTGGCCCCGGGGCATGGAGTACTTGGCCTCCCAGA
AGTGCATCCACAGGGACCTGGCTGCCCGCAATGTGCTGGTACCAGGACAACGTGATGAAGATCGCAGACTTCGGGCTG
GCCCCGGACGTGCACAACCTCGACTACTACAAGAAGACAACCAACGGCCGGCTGCCCGTGAAGTGGATGGCGCCTGAGGC
CTTGTGTTGACCGAGTCTACACTCACCAGAGTGACGTCTGGTCTTTGGGGTCTGCTCTGGGAGATCTTCACGCTGGGGG
GCTCCCCGTACCCCGGCATCCCTGTGGAGGAGCTCTTCAAGCTGCTGAAGGAGGGCCACCGCATGGACAAGCCCGCAAC
TGACACACGACCTGTACATGATCATGCGGGAGTGCTGGCATGCCGCGCCCTCCCAGAGGCCACCTTCAAGCAGCTGGT
GGAGGACCTGGACCGTGTCTTACCCTGACGTCCACCGACGAGTACCTGGACCTGTGCGGCGCCTTTCGAGCAGTACTCCC
CGGGTGGCCAGGACACCCCCAGCTCCAGCTCCTCAGGGGACGACTCCGTGTTTGGCCACGACCTGCTGCCCCGGCCCCA
CCAGCAGTGGGGGCTCGCGGACGTGA

Figure 2R

Mutant G377C FGFR3-IIIb:

ATGGGCGCCCTGCCTGCGCCCTCGCGCTCTGCGTGGCCGTGGCCATCGTGGCCGGCGCCCTCCTCGGAGTCTTGGGGAC
GGAGCAGCGCGTCTGTTGGGCGAGCGGCAGAAGTCCCGGGCCAGAGCCCGCCAGCAGGAGCAGTTGGTCTTCGGCAGCG
GGGATGCTGTGGAGCTGAGCTGTCCCCGCCCCGGGGTGGTCCCATGGGGCCACTGTCTGGGTCAAGGATGGCACAGGG
CTGGTGCCTCGGAGCGTGTCTGGTGGGGCCCCAGCGGCTGCAGGTGCTGAATGCCTCCCACGAGGACTCCGGGGCCTA
CAGTGCCTGGCAGCGGCTCACGCAGCGCGTACTGTGCCACTTCAAGTGTGCGGGTGCAGAGCAGCTCCATCCTCGGGAGATG
ACGAAGACGGGGAGGACGAGGCTGAGGACACAGGTGTGGACACAGGGGCCCTTACTGGACACGGCCCGAGCGGATGGAC
AAGAAGCTGCTGGCCGTGCCGGCCGCAACACCGTCCGCTTCCGCTGCCACGCGCTGGCAACCCCACTCCCTCCATCTC
CTGGCTGAAGAACGGCAGGGAGTCCCGGGCGAGCACCGCATTTGGAGGCATCAAGCTGCGGCATCAGCAGTGGAGCCTGG
TCATGGAAAGCGTGGTGCCTCGGACCGCGGCACTACACCTGCGTCTGGAGAACAAGTTTGGCAGCATCCGGCAGACG
TACACGCTGGACGTGCTGGAGCGCTCCCCGACCCGGCCATCCTGCAGGCGGGGCTGCCGGCCAACCAGACGGCGGTGCT
GGGCAGCGAGTGGAGTCCACTGCAAGGTGTACAGTGCAGCACAGCCCAATCCAGTGGCTCAAGCAGCTGGAGGTGA
ACGGCAGCAAGTGGGGCCGACGGCACACCCTACGTTACCGTGTCAAGTCTGGATCAGTGGAGTGTGGAGCCGCA
GTGCGCTCCGCCTGGCCAATGTGTGCGGAGCGGGACGGGGCGAGTACCTCTGTGAGCCACCAATTTTATAGGCGTGGC
CGAGAAGGCCTTTTGGCTGAGCGTTCACGGGCCCCGAGCAGCCGAGGAGGAGCTGGTGGAGGCTGACGAGGCGGGCAGTG
TGTATGCATGCATCCTCAGCTACGGGGTGGGCTTCTTCTGTTTATCCTGGTGGTGGCGGCTGTGACGCTCTGCCGCCTG
CGCAGCCCCCAAGAAAGGCCTGGGCTCCCCACCGTGCACAAGATCTCCCGCTTCCCGCTCAAGCGACAGGTGTCCCT
GGAGTCCAACCGCTCCATGAGCTCCAACACACCACTGGTGCAGCATCGCAAGGCTGTCCCTCAGGGGAGGGCCCCACGCTGG
CCATGTCTCCGAGCTCGAGCTGCCTGCCGACCCAAATGGGAGCTGTCTCGGGCCGGCTGACCCCTGGGCAAGCCCTT
GGGGAGGGCTGCTTCGGCCAGGTGGTTCATGGCGGAGGCCATCGGCATTGACAAGGACCGGGCCGCAAGCCTGTACCGT
AGCCGTGAAGATGCTGAAAGACGATGCCACTGACAAGGACCTGTGCGACCTGGTGTCTGAGATGGAGATGATGAAGATGA
TCGGGAAACACAAAAACATCATCAACCTGCTGGGCGCCTGCACGCAGGGCGGGCCCTGTACGTGCTGGTGGAGTACGG
GCCAAGGGTAACCTGCGGGAGTTTCTGCGGGCGCGGGCCCGCCCGGGCTGGACTACTCCTTCGACACCTGCAAGCCGCC
CGAGGAGCAGCTCACCTTCAAGGACCTGGTGTCTGTGCCTACCAGGTGGCCCGGGGCATGGAGTACTTGGCCTCCCAGA
AGTGCATCCACAGGGACCTGGCTGCCCGCAATGTGCTGGTGAACGAGGACAACGTGATGAAGATCGCAGACTTCGGGCTG
GCCCGGACGTGCACAACCTCGACTACTACAAGAAGACAACCAACGGCCGGCTGCCCGTGAAGTGGATGGCGCCTGAGGC
CTTGTGTTGACCGAGTCTACACTCACCAGAGTGACGCTCTGGTCTTTGGGGTCTGCTCTGGGAGATCTTACGCTGGGG
GCTCCCCGTACCCCGGCATCCCTGTGGAGGAGCTCTTCAAGCTGCTGAAGGAGGGCCACCGCATGGACAAGCCCGCAAC
TGACACACGACCTGTACATGATCATGCGGGAGTGTGGCATGCCGCGCCCTCCCAGAGGCCACCTTCAAGCAGCTGGT
GGAGGACCTGGACCGTGTCTTACCGTGCAGTCCACCGACGAGTACCTGGACCTGTCCGGCGCCTTTCGAGCAGTACTCCC
CGGGTGGCCAGGACACCCCAAGCTCCAGCTCCTCAGGGGACGACTCCGTGTTTGGCCACGACCTGCTGCCCGGGCCCA
CCAGCAGTGGGGCTCGCGGACGTGA

Figure 2S

Mutant A393E FGFR3-IIIb:

ATGGGGCCCCCTGCCTGCGCCCTCGCGCTCTGCGTGGCCGTGGCCATCGTGGCCGGCCCTCCTCGGAGTCCTTGGGGAC
GGAGCAGCGCGTTCGTGGGGCGAGCGGCAGAACTCCCGGGCCCAGAGCCCCGGCCAGCAGGAGCAGTTGGTCTTCGGCAGCG
GGGATGCTGTGGAGCTGAGCTGTCCCCCGCCCGGGGTGGTCCCATGGGGCCCACTGTCTGGGTCAAGGATGGCACAGGG
CTGGTGCCTTCGGAGCGTGTCTGGTGGGGCCCCAGCGGTGCAGGTGCTGAATGCCTCCCACGAGGACTCCGGGGCCTA
CAGTGCCTGGCAGCGGCTCACGCAGCGCTACTGTGCCACTTCAGTGTGCGGGTGACAGACGCTCCATCCTCGGGAGATG
ACGAAGACGGGGAGGACGAGGCTGAGGACACAGGTGTGGACACAGGGGCCCTTACTGGACACGGCCGAGCGGATGGAC
AAGAAGCTGCTGGCCGTGCCGGCCGCCAACCCGTCCGCTCCGCTGCCAGCCGCTGGCAACCCCACTCCCTCCATCTC
CTGGCTGAAGAAGCGCAGGGAGTTCGCGGGCGAGCACCGCATTGGAGGCATCAAGTGCGGCATCAGCAGTGGAGCCTGG
TCATGAAAAGCGTGGTGCCTCGGACCGCGGCAACTACACCTGCGTTCGTGGAGAACAAGTTTGGCAGCATCCGGCAGACG
TACACGCTGGACGTGCTGGAGCGCTCCCCGCACCGGCCATCCTGCAGGCGGGGCTGCCGGCCAAACCAGACGGCGGTGCT
GGGCAGCGACGTGGAGTTCCTACTGCAAGGTGTACAGTGACGCACAGCCCCACATCCAGTGGCTCAAGCACGTGGAGGTGA
ACGGCAGCAAGGTGGGCCCCGGACGGCACACCCTACGTTACCGTGTCTCAAGTCCCTGGATCAGTGAGAGTGTGGAGCCGAC
GTGCGCCTCCGCTGGCCAAATGTGTGGAGCGGGACGGGGCGAGTACCTCTGTGAGCCACCAATTTTCATAGGCGTGGC
CGAGAAGGCCTTTTGGCTGAGCGTTCACGGGCCCCGAGCAGCCGAGGAGGAGCTGGTGGAGGCTGACGAGGCGGGCAGTG
TGTATGCAGGCATCCTCAGCTACGGGGTGGGCTTCTTCTGTTTCATCCTGGTGGTGGAGGCTGTGACGCTCTGCCGCTG
CGCAGCCCCCCCCAAGAAAGGCCTGGGCTCCCCCACCCTGCACAAGATCTCCCGCTTCCCGCTCAAGCGACAGGTGTCCCT
GGAGTCCAACCGCTCCATGAGCTCCAACACACCCTGGTGGCATCGCAAGGCTGTCTCAGGGGAGGGCCCCACGCTGG
CCAATGTCTCCGAGCTCGAGCTGCCTGCCGACCCCAATGGGAGCTGTCTCGGGCCCGGCTGACCCTGGGCAAGCCCCTT
GGGGAGGGCTGCTTCGGCCAGGTGGTCAATGGCGGAGGCCATCGGCATTGACAAGGACCGGGCCGCCAAGCCTGTACCCT
AGCCGTGAAGATGCTGAAAGACGATGCCACTGACAAGGACCTGTCCGACCTGGTGTCTGAGATGGAGATGATGAAGATGA
TCGGGAAACACAAAACATCATCAACCTGCTGGGCGCCTGCACGCAGGGCGGGCCCTGTACGTGCTGGTGGAGTACGCG
GCCAAGGTAACCTGCGGGAGTTTCTGCGGGCGCGGCGCCCCCGGGCTGGACTACTCCTTCGACACCTGCAAGCCGCC
CGAGGAGCAGCTCACCTTCAAGGACCTGGTGTCTGTGCTACCAGGTGGCCCGGGGCATGGAGTACTTGGCCTCCCAGA
AGTGCATCCACAGGGACCTGGCTGCCGCAATGTGCTGGTACCAGGACACGCTGATGAAGATCGCAGACTTCGGGCTG
GCCCCGGACGTGCACAACCTCGACTACTACAAGAAGACAACCAACGGCCGGCTGCCCGTGAAGTGGATGGCGCCTGAGGC
CTTGTGTTGACCGAGTCTACACTCACCAGAGTGACGTCTGGTCTTTGGGGTCTGCTCTGGGAGATCTTACGCTGGGGG
GCTCCCCGTACCCCGCATCCCTGTGGAGGAGCTCTCAAGCTGCTGAAGGAGGGCCACCGCATGGACAAGCCCGCCAAC
TGCACACACGACCTGTACATGATCATGCGGGAGTGCTGGCATGCCGCGCCCTCCAGAGGGCCACCTTCAAGCAGCTGGT
GGAGGACCTGGACCGTGTCTTACCCTGACGTCCACCAGCAGTACCTGGACCTGTCCGGCCCTTTCGAGCAGTACTCCC
CGGGTGGCAGGACACCCCAAGCTCCAGCTCCTCAGGGACGACTCCGTGTTTGGCCACGACTGCTGCCCCGGCCCCA
CCAGCAGTGGGGGCTCGCGGACGTGA

Figure 2T

Mutant P250R FGFR3-IIIb:

ATGGGCGCCCTGCCTGCGCCCTCGCGCTCTGCGTGGCCGTGGCCATCGTGGCCGGCGCCCTCCTCGGAGTCCCTTGGGGAC
GGAGCAGCGCGTCTGTTGGGCGAGCGGCAGAAGTCCCGGGCCAGAGCCCGCCAGCAGGAGCAGTTGGTCTTGGCAGCG
GGGATGCTGTGGAGCTGAGCTGTCCCCGCCCCGGGGTGGTCCCATGGGGCCCACTGTCTGGGTCAAGGATGGCACAGGG
CTGGTGCCCTCGGAGCGTGTCTGGTGGGGCCCCAGCGGCTGCAGGTGTGAATGCCTCCCACGAGGACTCCGGGGCCTA
CAGCTGCCGGCAGCGGCTCACGCAGCGGTAAGTGTGCCACTTCAAGTGTGGGGTGCAGACGCTCCATCCTCGGGAGATG
ACGAAGACGGGAGGACGAGGCTGAGGACACAGGTGTGGACACAGGGGCCCTTACTGGACACGGCCGAGCGGATGGAC
AAGAAGCTGCTGGCCGTGCCGGCCGCCAACACCGTCCGCTTCCGCTGCCAGCCGCTGGCAACCCCACTCCCTCCATCTC
CTGGTGAAGAACGGCAGGGAGTTCCGCGGGCAGCACCCGATTGGAGGCATCAAGCTGGGCATCAGCAGTGGAGCCTGG
TCATGGAAAGCGTGGTGGCCCTCGGACCGCGGCAACTACACCTGCGTCTGGGAGAACAAGTTTGGCAGCATCCGGCAGACG
TACACGCTGGACGTGCTGGAGCGTCCCCGGCACCCGCCATCCTGCAGGGGGGCTGCCGGCCAACAGACGGCGGTGCT
GGGCAGCGACGTGGAGTTCACCTGCAAGGTGTACAGTGACGCACAGCCCCACATCCAGTGGCTCAAGCACGTGGAGGTGA
ACGGCAGCAAGGTGGGCCCCGACGGCACACCCTACGTTACCGTGTCAAGTCTGGATCAGTGAGAGTGTGGAGGCCGAC
GTGCGCTCCGCTGGCCAATGTGTGCGAGCGGACGGGGCGAGTACCTCTGTGAGCCACCAATTTTATAGGCGTGGC
CGAGAAGGCCTTTTGGCTGAGCGTTACGGGGCCCCGAGCAGCCGAGGAGGAGCTGGTGGAGGCTGACGAGCGGGCAGT
TGTATGCAGGCATCCTCAGCTACGGGGTGGGCTTCTTCTGTTTATCCTGGTGGTGGCGGCTGTGACGCTCTGCCGCTG
CGCAGCCCCCAAGAAAGGCTGGGCTCCCCACCGTGCACAAGATCTCCGCTTCCCGCTCAAGCGACAGGTGTCCCT
GGAGTCCAACGCGTCCATGAGCTCCAACACACCACTGGTGCATCGCAAGGCTGTCTCAGGGGAGGGCCCCACGCTGG
CCAATGTCTCCGAGCTCGAGCTGCCTGCCACCCCAATGGAGCTGTCTCGGGCCCGGCTGACCCTGGGCAAGCCCTT
GGGGAGGGCTGCTTCGGCCAGGTGGTTCATGGCGGAGGCCATCGGCATTGACAAGGACCGGGCCGCAAGCCTGTACCCTG
AGCCGTGAAGATGCTGAAAGACGATGCCACTGACAAGGACCTGTGCGACCTGGTGTCTGAGATGGAGATGATGAAGATGA
TCGGGAAACACAAAAACATCATCAACCTGCTGGGCGCCTGCACGCAGGGCGGGCCCTGTACGTGCTGGTGGAGTACCG
GCCAAGGGTAACCTGCGGGAGTTTCTGCGGGCGCGGGCCCCGGGCTGGACTACTCCTTCGACACCTGCAAGCCGCC
CGAGGAGCAGCTCACCTTCAAGGACCTGGTGTCTGTGCTTACCAGGTGGCCCGGGGCATGGAGTACTTGGCCTCCCAGA
AGTGCATCCACAGGGACCTGGCTGCCCGCAATGTGCTGGTACCGAGGACAACGTGATGAAGATCGCAGACTTCCGGCTG
GCCGGGACGTGCACAACCTCGACTACTACAAGAAGACAACCAACGGCCGGCTGCCCGTGAAGTGGATGGCGCCTGAGGC
CTTGTGTTGACCGAGTCTACACTCACCAGAGTACGCTCTGGTCTTTGGGGTCTGCTCTGGGAGATCTTACGCTGGGG
GCTCCCCGTACCCCGGCATCCCTGTGGAGGAGCTCTTCAAGCTGCTGAAGGAGGGCCACCGCATGGACAAGCCCGCCAC
TGACACACGACCTGTACATGATCATGCGGGAGTGTGGCATGCCGCGCCCTCCAGAGGCCACCTTCAAGCAGCTGGT
GGAGGACCTGGACCGTGTCTTACCCTGACGTCCACCGACGAGTACCTGGACCTGTGCGCGCCTTTTCGAGCAGTACTCCC
CGGGTGGCCAGGACACCCCACTCCAGCTCCTCAGGGGACGACTCCGTGTTGCCACGACCTGCTGCCCGGGCCCCA
CCCAGCAGTGGGGCTCGCGGACGTGA

FIGURE 3

