

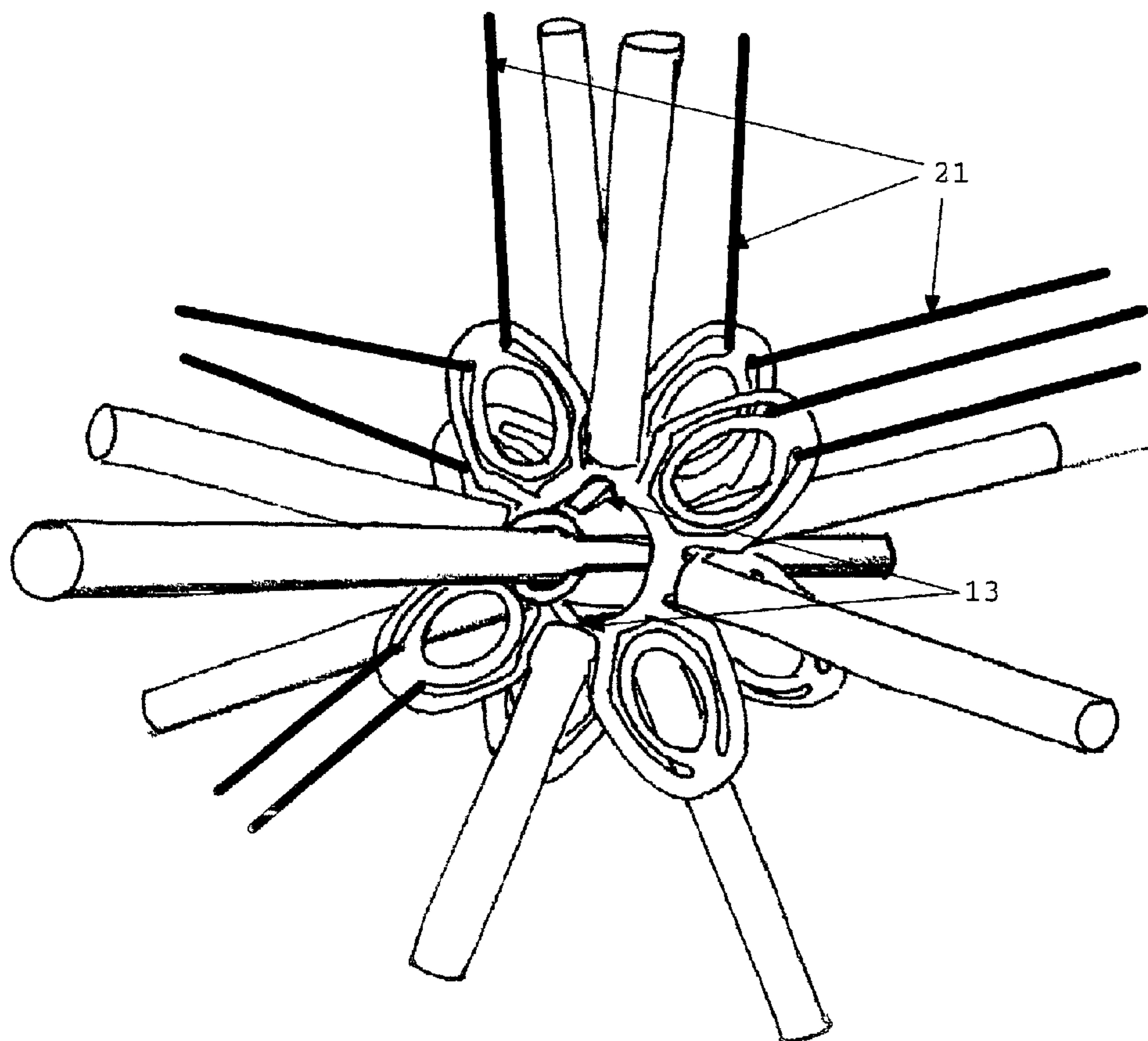

(86) Date de dépôt PCT/PCT Filing Date: 2003/07/11
 (87) Date publication PCT/PCT Publication Date: 2004/02/05
 (85) Entrée phase nationale/National Entry: 2005/01/12
 (86) N° demande PCT/PCT Application No.: FR 2003/002195
 (87) N° publication PCT/PCT Publication No.: 2004/012170
 (30) Priorités/Priorities: 2002/07/24 (02/09363) FR;
 2003/04/22 (03/04910) FR

(51) Cl.Int.⁷/Int.Cl.⁷ G09B 23/00, F16B 7/04
 (71) Demandeur/Applicant:
 RANTRUA, JEAN, FR
 (72) Inventeur/Inventor:
 RANTRUA, JEAN, FR
 (74) Agent: MOFFAT & CO.

(54) Titre : DISPOSITIF D'ASSEMBLAGE DE TUBES
 (54) Title: TUBE ASSEMBLING DEVICE



(57) Abrégé/Abstract:

The invention concerns a tube assembling device consisting of hub-carriers and hubs for erecting three-dimensional structures. Said hub-carriers consist of two pairs of half-rings (8 and 9), bearing tongues (1 and 14) offset by 90° along an antero-posterior axis and linked by four connecting lugs (10 and 11), they support radial hook-shaped expansions (5, 6, 7). Said hub-carriers can

(57) **Abrégé(suite)/Abstract(continued):**

link two tubes in a fixed or balanced position, can be fixed at the tube end, can be fixed along a tube and support hubs. The hubs support tongues (3) which are positioned folded or unfolded inside the tubes used for the construction of the radial expansions into rings (4) and catching teeth (5, 6 7) internal to said rings (4). The assembly enables the hubs and hub-carriers to be linked by tubes or preferably elastic links and constitute by folding or combining the hubs and hub-carriers nodes for modelling structures of numerous types from a reduced number of elements.

ABSTRACT

The invention concerns a tube assembling device consisting of hub-carriers and hubs for erecting three-dimensional structures. Said hub-carriers consist of two pairs of half-rings (8 and 9), bearing tongues (1 and 14) offset by 90° along an antero-posterior axis and linked by four connecting lugs (10 and 11), they support radial hook-shaped expansions (5, 6, 7). Said hub-carriers can link two tubes in a fixed or balanced position, can be fixed at the tube end, can be fixed along a tube and support hubs. The hubs support tongues (3) which are positioned folded or unfolded inside the tubes used for the construction of the radial expansions into rings (4) and catching teeth (5, 6 7) internal to said rings (4). The assembly enables the hubs and hub-carriers to be linked by tubes or preferably elastic links and constitute by folding or combining the hubs and hub-carriers nodes for modelling structures of numerous types from a reduced number of elements.

TUBE ASSEMBLING DEVICE

The invention relates to a tube-assembling device consisting of flexible hubs, hub-carriers and tubes for erecting two- or three- dimensional structures, which may be rigid, convertible or elastic. Those structural elements may be used for art teaching, for the study and application of Geometry, Chemistry, Technology or any other subject which is often made easier by the construction of two- or three- dimensional structures. Those assemblies may also be used for building structures fitted for housing or furniture if suitable device and materials are used.

Said three-dimensional structures are made of junction nodes and tubes. Said nodes of the structure may be either elementary, i.e. composed of a single hub, or complex ,i.e. composed of several hubs combined directly or through a hub-carrier.

This device allows:

- to connect to a hub to tubes of different diameters, typically 25% more or less of a said average value defined for the dimensions of a hub or a hub-carrier.
- to obtain the required length between two nodes by cutting the tube to the right length without any transformation of end of tubes. used in the structure.
- to obtain a great diversity in the number of arms resulting from a single or a complex node.
- to obtain numerous direction for arms stemming from a node with a reduced number of elementary hubs.
- to fix a simple or a complex node at the end of a tube.
- to adjust a node along a tube, which once adjusted, may remain movable on the tube.

- to obtain a high cohesion between the elements of the device by linking building elements of said structure with elastic or non-elastic bonds fixed on specific parts of hubs and hub-carriers.

One or several hubs can be fixed on the outer side of a hub-carrier. The inner side of a hub-carrier includes tongues (1), which may be inserted into the tube representing the axis of the structure, or surround the said tube.

Radial hook-shaped expansions (2) on the connecting lugs (10, 11) of a said hub-carrier or on divergent tongues (12) coming out from anterior half rings (8) of a said hub-carrier enable the said hub-carrier to be connected to other elements of structures with preferably elastic links (21) for modelling structures which may be deformed.

Hubs consist of radial arms (3) and radial rings (4) with internal catching teeth (5, 6, 7) in direction of the said hub's axis. These catching teeth may be linear (5) or anchor shaped (6). Said catching teeth may show an inner circular or oblong hole (7) wide enough to insert a tube used for the structure.

When assembling the device, hubs, hub-carriers and tubes may be combined directly or indirectly with one another for modelling structures of numerous types.

Links (21) connecting different elements of the device may be fixed to the tooth shaped expansions (5, 6, 7) of the hub axial ring. It also makes it possible to insert a tube in the hole (20) of one or several catching teeth (7) hold by one or several radial rings or by one or several hub's radial rings (4) themselves if the diameter of the tube is superior to the maximal diameter usable for tooth hole (7) of said radial rings.

These catching teeth (5, 6, 7) may also be inserted into a tube's end by being slightly compressed if they belong to the anchor shaped type (6) or to the pierced type (7).

Attached drawings describes the invention:

Fig.1 shows a hub-carrier with hook-shaped expansions on connecting lugs.

Fig. 2 is the partial view of a hub-carrier's inner structure supporting a pair of divergent tongues (12) issued from anterior half rings.

5 Fig. 3 shows a hub which teeth have a linear shape.

Fig. 4 shows a hub which teeth have an anchor shaped type.

Fig. 5 shows a hub with pierced teeth.

Fig. 6 shows a partial view of a hub-carrier's inner side fixed at a tube's end.

10 The tube not being completely pushed inside, one of the posterior (14) and one of the anterior (1) tongues are not illustrated to show the position of the different building elements.

Fig. 7 shows a partial view of a hub-carrier's inner side connecting two tubes. The tubes not being completely pushed inside, one of the posterior (14) and one of the anterior (1) tongues are not illustrated to show the position of the building elements.

15

Fig. 8 is the view of a hub-carrier connecting two tubes and supporting two hubs with illustration of some elastic links.

Fig. 9 is the view of hub's folding when a tube is inserted though hub's radial rings (4).

20 Fig. 10 is the view of a tube being inserted into the axial hole of a hub and inside the radial rings (4) of said hub.

Fig. 11 is the view of a hub being folded along the axis of two opposite tongues (3).

25 Fig. 12 is the view of a hub being folded along the axis of two opposite radial rings (4).

Fig. 13 is the view of two adjacent tongues (3) of a hub when being folded.

Fig. 14 is the view of two opposite hub's pair of tongues (3) being folded in opposite directions.

Fig. 15 shows two hubs being combined with one another by insertion of a pair of radial rings into the axial hole of another hub.

Fig. 16 shows two hubs being combined with one another by insertion of a pair of opposite radial rings (4) into the radial rings (4) of another hub.

5 Fig. 17 is the view of a basic building structure showing the circular track of an elastic link.

Fig. 18 is the view of a basic building structure with hubs with three tongues connected by two kinds of links.

10 Hub-carriers are made of four half rings (8, 9): two anterior half rings (8) and two posterior half rings (9) linked by four connecting lugs (10, 11). Said lugs (10, 11) make an approximate 90° angle with the half ring's surface (8, 9) of said hub-carriers.

15 Anterior (8) and posterior (9) pairs of said half rings are shifted of 90 degrees along an antero-posterior axis. Said half rings show complementary convex (18) and concave (19) surfaces , which makes it possible to set them up steadily one versus the other by placing face to face complementary concave and convex faces .

20 The two upper connecting lugs (10) link the posterior lateral parts of one anterior half ring (8) to the upper parts of left and right posterior half rings (9) of said hub-carrier. The 2 lower connecting lugs (11) link the posterior lateral parts of the second anterior half ring (8) to the lower parts of left and right posterior half rings (9) of said hub-carrier.

25 Lugs (10, 11) of said hub-carrier are flexible and may show flexible radial hook-shaped expansions (2). Said expansions allow the location of one or several hubs on said hub-carrier and enable to fix the elastic links, which may connect hub-carriers to other building elements of the structure.

The hub positioning may also occur through a pair of tongues (12) coming out from the middle part of the anterior half rings (8) of said hub-carriers.

Said tongues have, outside of their middle part, expansions (13) between which hubs are fixed when placed on a said hub-carrier.

A tongue (1) with a convex external side is issued from the posterior side of each anterior half ring (8) of said hub-carriers. Said tongue reaches or even goes beyond the level of posterior half rings (9) and nearly reaches the other tongue (1) issued from the other anterior half ring (8) at the same level or after posterior half rings (9) of said hub-carriers.

A tongue with a convex external side (14) comes out from the posterior part of each posterior half ring (9) of said hub-carriers. Said tongue reaches or even outreaches the level of anterior half rings (8) of said hub-carriers. Those tongues are more narrow and thicker at their basis.

Each tongue is narrow (15) on its first approximate half length; then at its approximate middle length it shows a sudden widening with an angle of approx 90° and shows a curve to reach its maximum of width (16). This part of the tongue (1, 14) is bevel-edged towards the inside.

The wider part of said tongues of said hub-carriers shows straight longitudinal sides, which may be thinner than the axial part of said tongues (1, 14).

From those two pairs of tongues, one pair comes from the posterior (14) side and the other comes from the anterior side (1) of a said hub-carrier. The anterior pair (1) belongs to the inner part of said hub-carrier and shows convergent ends. The posterior pair (14) of tongues belongs to the external part of said hub-carrier when the said hub-carrier is not used. But, under normal use, said posterior tongues (14) are pushed inside the said hub-carrier by pushing aside the connecting lugs (10, 11) of said hub-carriers.

Once said posterior tongues (14) have been pushed between the connecting lugs of a said hub-carrier, said connecting lugs (10, 11) come back into their original closed position and avoid that said posterior tongues (14) come out

unintendedly. Connecting lugs (10, 11) of said hub-carriers may be made thinner in this part to allow an easier positioning of said posterior tongues (14). Therefore once the tongues (14) have been pushed inside the hub-carrier there is two pairs of tongues (1, 14) issued from opposite sides of said hub-carrier and offset by 90° along an antero-posterior axis.

When one insert a axis into a said hub-carrier, if tongues (1, 14) of said hub-carrier penetrate into the axis, that is if the said hub-carrier is placed at the end of the axis, then the said tube is compressed on one hand by the tongues (1, 14) located inside the said tube and on the other hand by the other pair of tongues and the half rings (8, 9) of said hub-carrier which are pressed on the external side of the said tube. This pressure is increased by the positioning of a hub on a hub-carrier.

If the tongues (1, 14) of a said hub-carrier remain on the external side of the tube, said tube is slightly compressed by half rings (8, 9) via internal tongues (1, 14) of said hub-carrier.

Said hub-carriers also enable to connect two tubes. To achieve this, one has to fix a tube at each end of a hub-carrier by inserting one tube into the posterior part through anterior tongues (1) of said hub-carrier and inserting the second one into the anterior part through the posterior tongues (14) of said hub-carrier.

Each tube is inserted up to the middle part of said hub-carrier. Opposite tongues (1, 14) cross each other and proximal parts of each pair of said tongues (1, 14) are pressed by the pressure of the tube on the distal parts of the other pair of said tongues which fix the tube. This set-up is improved if said hub-carrier carries a hub.

The complementarity of convex and concave forms of anterior face (8) and posterior face (9) of half ring of said hub-carrier make it possible to fit

together two sub-structures for creating an oscillating or rotating balanced assembly when two hub-carriers are placed face to face.

Hub carried by said hub-carriers show a flat or cone-shaped axial ring side (17) with a centred hole in it, said hole has a diameter inferior to the biggest width of radial rings (4) of the said hub. Radial expansions, in the form of elongated tongues (3), come from this axial ring (17). Said tongues (3) are narrower at their end and around the middle of each said tongue (3). They may show an oblong hole close to the connexion between a said radial ring and a said axial ring (17) of a said hub. Another tongue (3) issued from the same or from another said hub may be passed through this elongated hole in order to change the structure of the node. Hook-shaped or ring-shaped expansions (7) are placed between those tongues (3) and show on their inner side a catching tooth (5, 6, 7) in direction of the axis of radial rings (4) of said hub.

In the middle lateral part of those expansions (4) there is an external prominent zone (22) allowing a better connection of radial rings (4) of a said hub when inserted into the axial hole of a said hub or into another radial ring of a said hub (4) if several hubs are combined with each other.

Said hubs are made of a flexible material. Different spatial configurations expansions of said hubs result from bending the hub along different angles. Either by bending the hub itself or by inserting one or several elements of the hub into one or several elements of the same hub or into another hub it is combined with.

Radial tongues (3) come into the tubes of the structure. One tube may receive one or several tongues (3) of one or different several said hubs. Said radial tongues (3) may be inserted unfolded or folded to increase the quality of the link between the tongue and the tube by the internal pressure of the said tongue inside the said tube.

The catching tooth (5, 6, 7) of a radial ring (4) of a said hub is thicker or wider at its junction point with the radial ring (4). This junction shows round lateral sides in order not to damage the link(s) it supports in some cases. This tooth may be linear (5) and filling at least half of the radial ring's hole (20) or anchor-shaped (6) which makes it possible for the elastic links it may support to endure many different forces without being possible for the link to get free from the said radial ring's (4) tooth (6). Finally the tooth of said radial ring may show an elongated hole (7) enabling to fix elastic links at its junction part with the radial ring (4) but also, when a hub is folded, to pass a tube through this pierced tooth (7) connected to the radial ring (4) by a lug (23).

The insertion of a tube into a said pierced tooth (7) allows:

- when two said radial rings (4) are folded, to insert a tube in a direction parallel to the plan of the said hub (fig. 9).
- when said hub is made of 4 radial rings (4) and when opposite said radial rings are bended on each side of the hub, the crossing of 2 tubes at a 90° angle on each side of said hub .
- When said hub is made of 4 radial rings (4) the bending of two opposite said radial rings (4) added to the bending of said pierced teeth (7) allows the insertion and fixing (fig. 10) through the said pierced teeth (7) of a tube getting through the axis of the said hub and through the hole (20) of said radial rings (4).

In the case of a hub made of four tongues (3) and four radial rings (4), one may consider the different non-exhaustive possibilities:

- a bending/folding along the axis of two opposite tongues (3) which results in a hub with 3 orthogonal arms (fig. 11)
- a bending/folding along the axis of two radial rings (4) (fig. 12) which results in the creation of a hub made of two pairs of perpendicular arms.

- a folding of a tongue (3) of a said hub over the next tongue (3) (fig. 13) resulting in the modelling of a hub made of legs radiating in 3 different directions only, instead of the four original ones of said 4 rings hub.

- a bending of two pairs of tongues (3) in opposite direction (fig. 14) which makes it possible, if said tongues (3) of a same pair are pressed one against the other, thus misshaping the axial ring (17) of a said hub, to obtain 2 pairs of opposite tongues (3) on which "to be connected" tubes may be inserted.

Elementary hubs may be combined with one another and form complex hubs. For example, it is possible to combine them – without being exhaustive – as follows:

- the bending of two opposite radial rings (4) on the same side of the axial ring (17) enables, by pushing two pierced teeth (7) one against the other towards the hub-carrier axis, allows to fix this said hub-carrier at the end of a tube by inserting said tube into the above mentioned teeth.

- a hub can be combined to one or several other hubs by inserting one or several radial rings (4) into the axial hole of another hub (fig. 15).

- to combine hubs with one another by inserting two radial rings (4) belonging to different hubs by placing two contiguous hubs, one over the other (fig. 16) or, side by side.

- to combine different hubs by inserting one or several tongues (3) into the hole located at the basis of one or several tongues (3) of different hubs.

- to combine different hubs by inserting conversely or non-conversely radial tongues (3) into the axial hole of another said hub.

These different possible ways of combining building elements are not limited and each one of them can be in turn combined with another one, which still increases the number of possible types of structures.

Links (21) used to connect hub-carriers or to connect hubs are preferably elastic links, they link elements close to one another (fig. 17, fig. 18) for

example the tops of a polygon being part of the built structure or distant building elements.

If radial rings (4) have teeth (7) showing a hole (20), the crossing section (23) between this tooth (7) and the radial ring (4) may show thicker sides and
5 a thinner axial part in order to allow the folding of the radial ring (4) along the axis of this thinner part to ease the insertion of one radial ring (4) into one of the tubes being part of a bi- or three- dimensional structure.

CLAIMS

1- A tube assembling device consisting of flexible hubs and hub-carriers designed for tubes of various diameters and allowing the assembly of raw tubes which may be cut at the required length and may be used without any modification of their end sections, for erecting two- or three- dimensional rigid or elastic structures. Those structures are fitted for the teaching, the study and the application of Geometry, Chemistry or any other subject whose teaching is often eased by the building of two- or three- dimensional structures as well as by the modeling of other structural elements fitted for any other use, said hubs of this said tube assembling device comprise a conical axial part or a flat axial part with a hole in the middle of the said axial part, around which are set out: on one hand , flexible tongues (3) showing a narrow part in the middle of their length and , on the other hand, radial rings (4) showing catching teeth (5, 6, 7) , said catching teeth are steered according to the axis of the hub, so that said flexible tongues (3) may be inserted inside the tubes used in the assembly, folded at the level of their narrow section or unfolded and so that links (21) of the structure can be fixed at the basis of catching teeth (5, 6, 7) of said radial rings (4). Said Flexible hub-carriers can connect tubes and hubs can be placed on said hub-carriers, said hub-carriers show radial external hook-shaped expansions (2) and show 2 pairs of half rings, one posterior pair (9) and one anterior pair (8) linked by four connecting lugs (10, 11), said lugs of said hub-carriers are moved with 90° around an antero-posterior axis, from these said pairs of half-rings come out at least one pair of tongues (1) pointing in the direction of the pair of half rings (9) located at the opposite side of the basis of the said pair of tongues so that when a tube is inserted into the hub-carrier either all tongues (1, 14) remain outside and positioning of said hub-carrier is made

all along the tube which is slightly compressed between the tongues (1, 14), or some tongues (1, 14) are inserted inside the said tube and positioning of the hub-carrier occurs at tube's end.

5 2- A tube assembling device according to claim 1 wherein the said hub-carrier comprise 4 connecting lugs (10, 11) who have flexible hook-shaped radial expansions (2) enabling to fix elastic links (21) which may bind the different structural elements and lock one or several said hubs which may be fixed on the hub-carrier. In that case the pressure applied by the hubs, when hub-carrier is fixed along the tube, i.e. when tongues (1, 14) remain outside
10 the tube, increases the pressure applied by the tongues (1, 14) on the tube, and, when the tongues (1-14) are inserted inside the tube, i.e. when hub-carrier is fixed at a tube's end, said tube is squeezed between the tongues (1, 14) located inside the tube and the half rings (8, 9) located outside the same tube.

15 3- A tube assembling device according to claim 1 wherein divergent tongues (12) of a said hub-carrier are issued from anterior half rings of said hub-carrier and in which said divergent tongues show expansions (13) before and after the median zone of said divergent tongues, between these said expansion hubs are fixed on said hub-carriers.

20 4- A tube assembling device according to claim 1 wherein hub-carriers shows tongues (1) coming from anterior half rings (8) of said hub-carrier, said tongues converge towards the axis of said hub-carrier and go towards the posterior part of said hub-carrier.

25 5- A tube assembling device according to claim 1 wherein hub-carrier shows a pair of divergent tongues (14) issued from posterior half rings (9) going to the anterior half rings (8) of said hub-carrier, said tongues (14) have a maximal width superior to the open space left between the connecting lugs

(10, 11) of said hub-carrier so that said divergent tongues may be locked inside the hub-carrier when they are pushed inside said hub-carrier.

6- A tube assembling device according to claim 1 wherein connecting lugs (10, 11) of said hub-carrier show an inferior thickness where the second pair of tongues (14) of said hub-carrier are located when pushed into said hub-carrier.

7- A tube assembling device according to claim 1 wherein tongues (1, 14) of said hub-carriers show first a narrow proximal half part and then widen in their middle part to reach their maximal width so that when tubes are inserted through the two ends of a said hub-carrier, tongues (1) issued from anterior half rings (8) come into the inserted tube through the posterior part of said hub-carrier and tongues (14) issued from posterior half rings (9) come into the inserted tube through the anterior part of said hub-carriers. Thus the two pairs of tongues (1, 14) cross each other and the proximal parts of each pair close on the distal parts of the other pair of said tongues which enables two tubes to be connected by their ends.

8- A tube assembling device according to claim 1 wherein superior connecting lugs (10) of said hub-carriers link the lateral posterior parts of one anterior half ring (8) of said hub-carriers to the upper parts of left and right posterior half rings (9) of said hub-carriers and that inferior connecting lugs (11) of said hub-carriers link the lateral posterior parts of the second anterior half ring (8) of said hub-carriers to the lower parts of left and right posterior half rings (9) of said hub-carriers.

9-A tube assembling device according to claim 1 wherein catching teeth of radial rings (4) of said hubs are anchor-shaped (6) so that the pulling force of the links (21) may be aimed towards many different directions without links (21) getting loose from the said tooth (6).

10- A tube assembling device according to claim 1 wherein catching teeth of radial rings (4) of said hubs are perforated by a hole which diameter is large enough to allow the insertion of a tube used for building the structure.

5 11- A tube assembling device according to claim 1 wherein radial rings (4) of said hubs show external prominent zones (22) to lock the radial rings (4) when inserted into the axial hole of a said hub or when inserted into another radial ring (4) of a hub.

10 12- A tube assembling device according to claim 1 wherein the junction point between a radial ring (4) of a said hub and the inside catching tooth (5, 6, 7) of the said radial ring (4) is wider or thicker at least on the edges to avoid that this tooth turns inside out under the pulling force of the links (21).

15 13- A tube assembling device according to claim 1 wherein the junction point (23) between an inside tooth (5, 6, 7) of a radial ring (4) of a said hub and an axial ring (17) of the said hub shows a smoothed border in order not to damage the links it holds.

20 14- A tube assembling device according to claim 1 wherein the outer sides (18, 19) of anterior (8) and posterior (9) half rings of said hub-carriers show complementary convex and concave shapes so that 2 hub-carriers may build an oscillating or rotating balanced structure when placing complementary sides of two different hub-carriers face to face.

15- A tube assembling device according to claim 1 wherein tongues (1, 14) of said hub-carriers have a slightly narrower end part, bevel-edged towards the outside to ease insertion of said tongues (1, 14).

25 16- A tube assembling device according to claim 1 wherein tongues (3) of said hubs have an elongated hole at their basis so that another tongue (3) of a said hub may be inserted and remain fixed.

17- A device according to claim 1 wherein radial rings (4) of said hub show near the axial ring (17) of said hub a lug which connects the 2 sides of the

said radial ring (4) and enables, when 2 hubs are combined, to insert a tongue (3) inside the hole formed by this said lug and the hub's axial ring (17)

5 18- A device according to claim 1 wherein connecting lugs (23) linking one tooth (7) of a radial ring of a hub to the same radial ring show at least on one side a narrow axial depressed zone to increase the flexibility of the said tooth (7) enabling the insertion of a radial ring (4) and of its said tooth (7) into a tube of the structure.

fig. 1

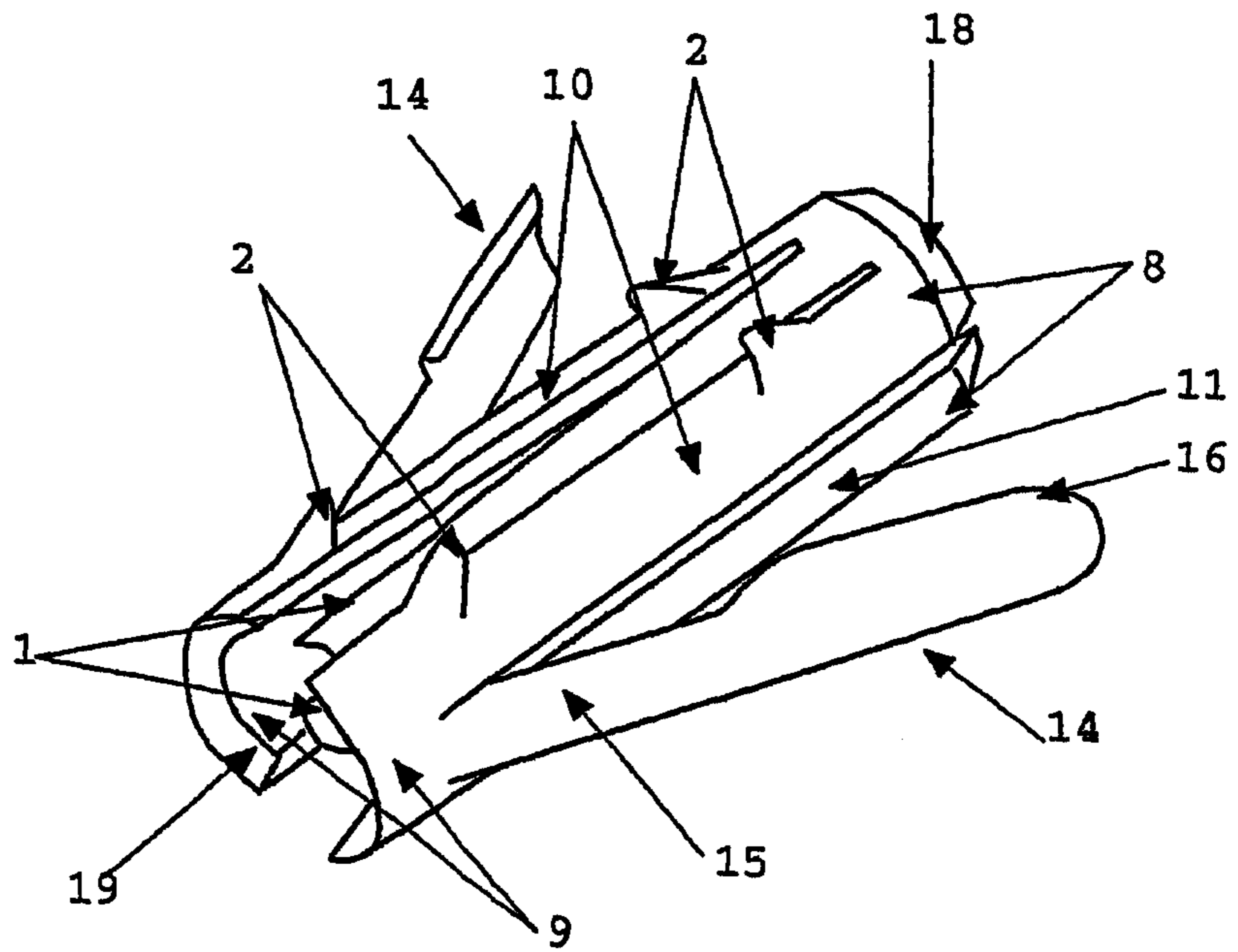

fig. 2

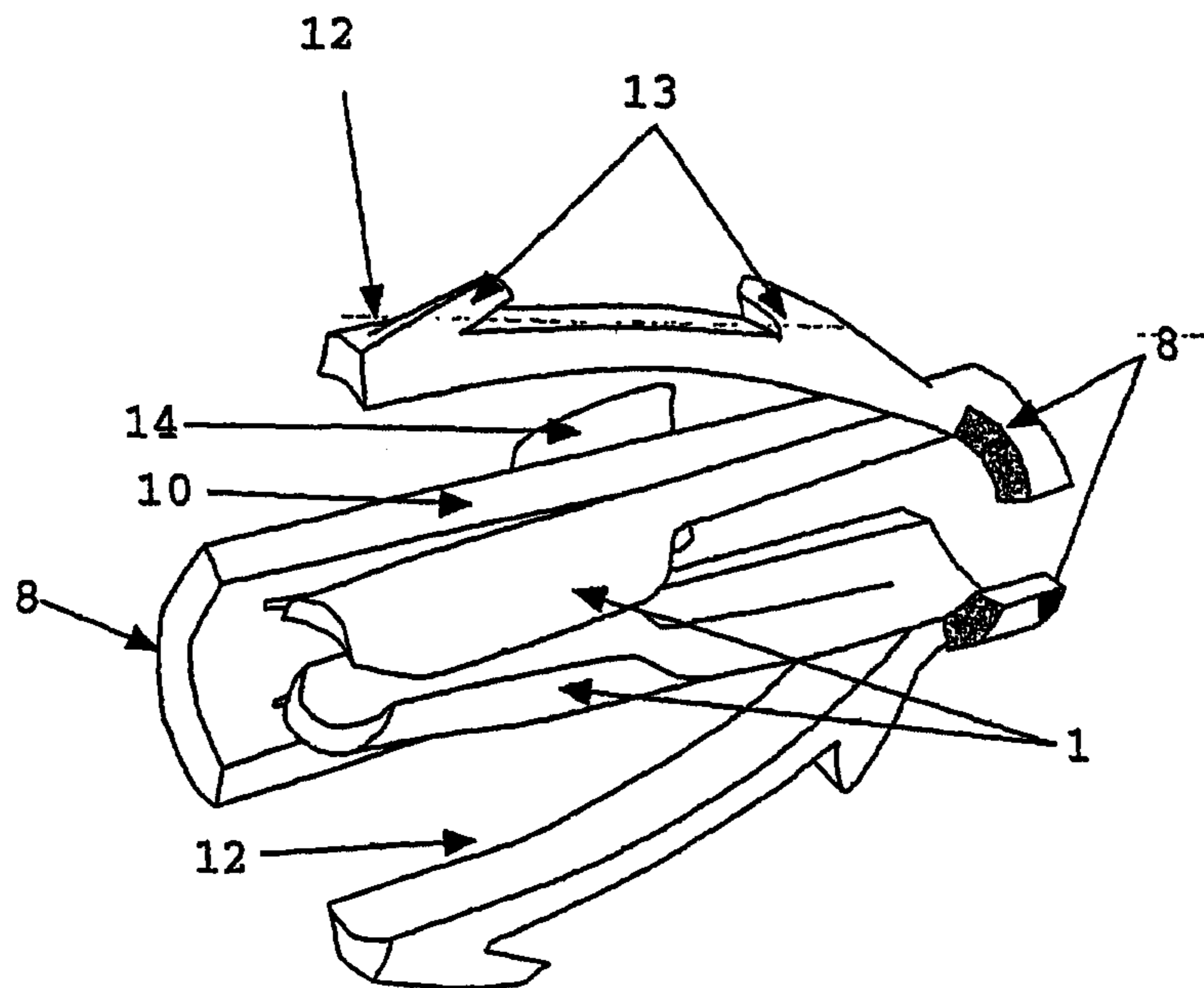

fig. 3

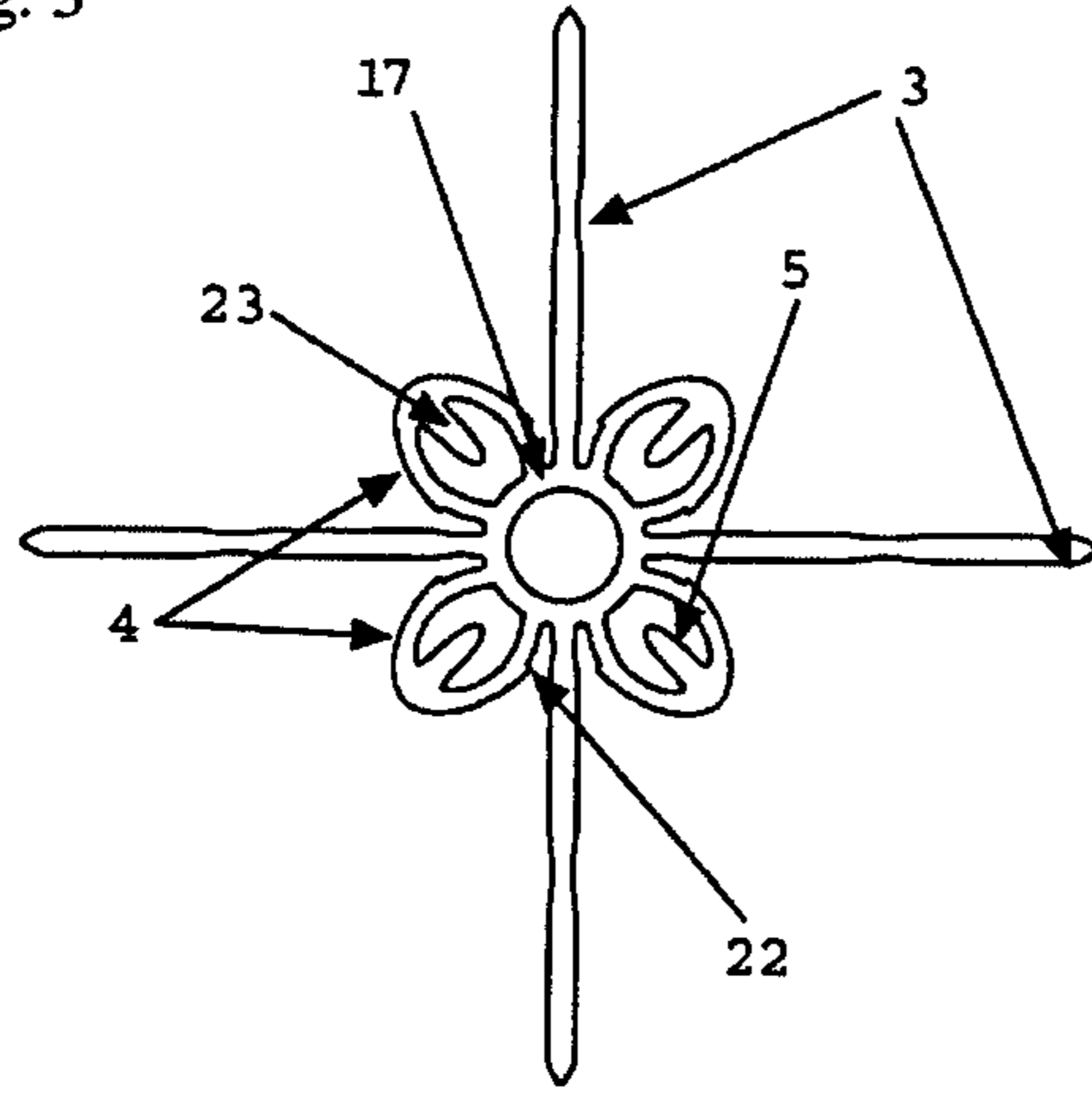

fig. 4

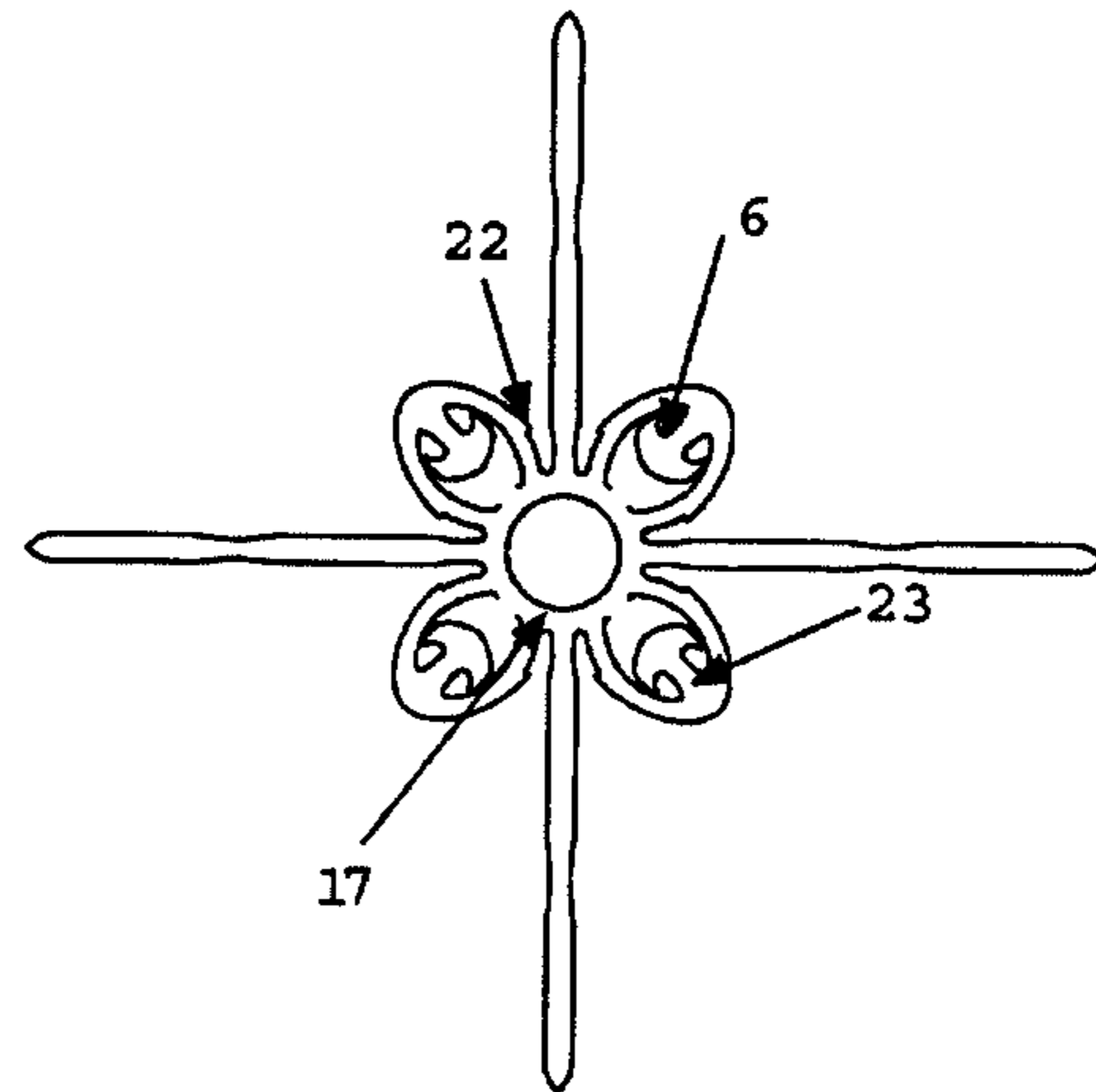

fig. 5

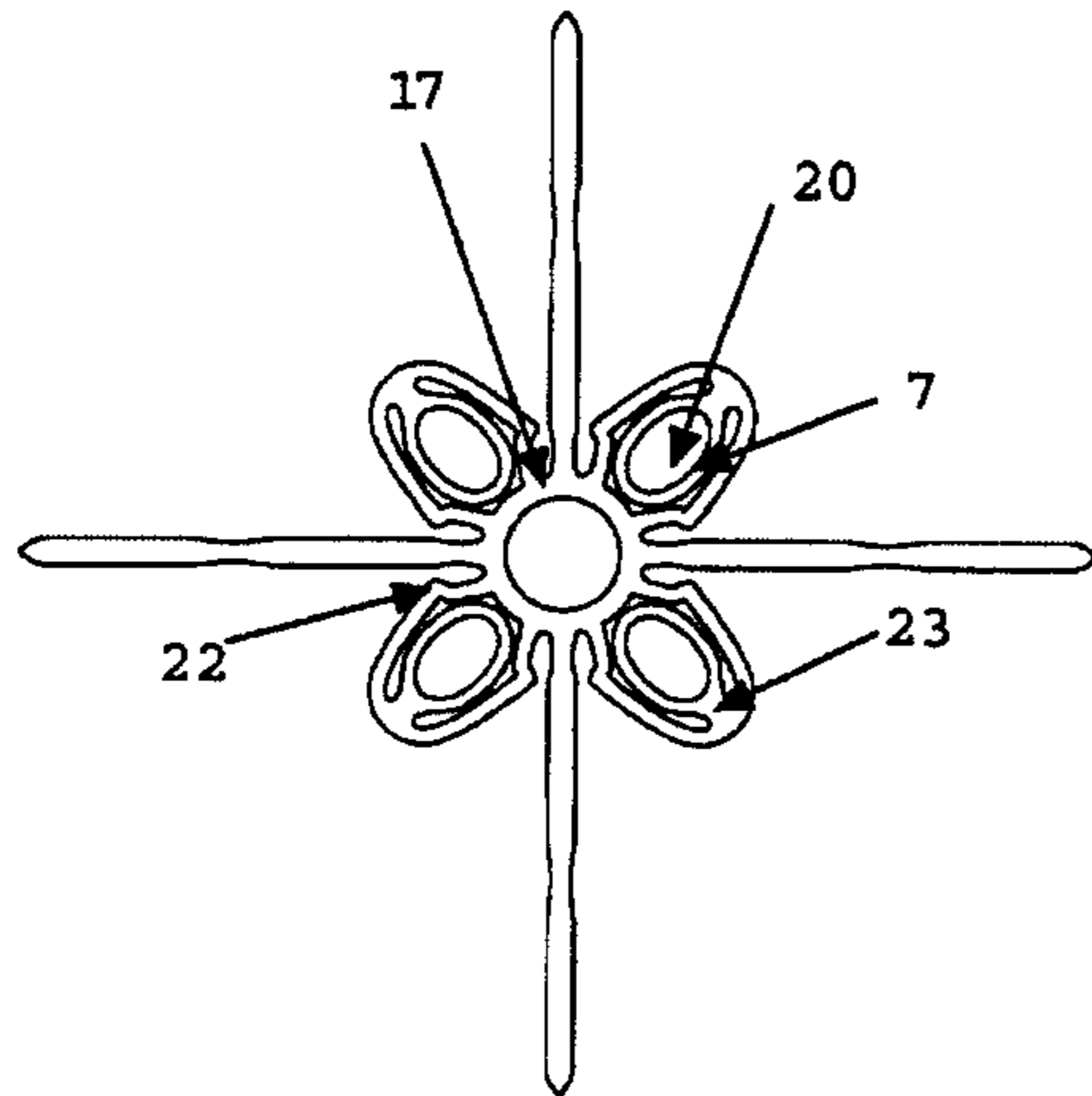

fig. 6

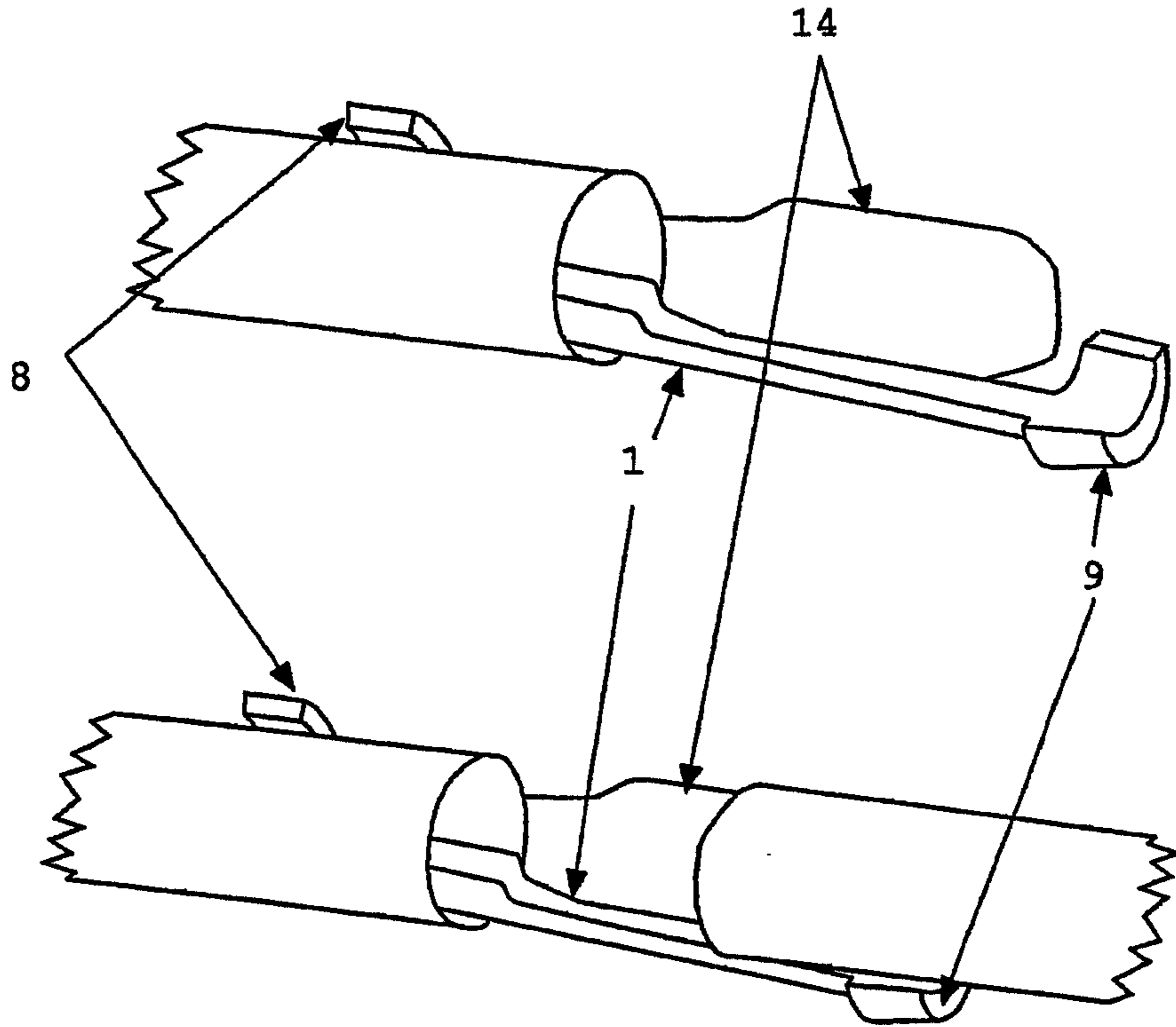

fig. 7

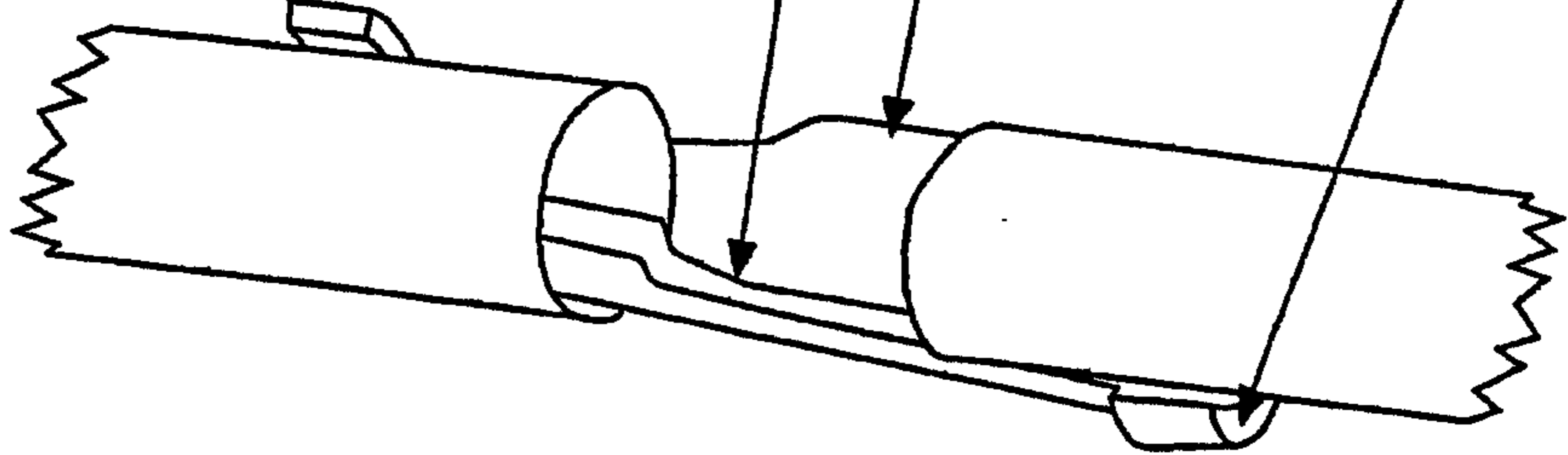

fig. 8

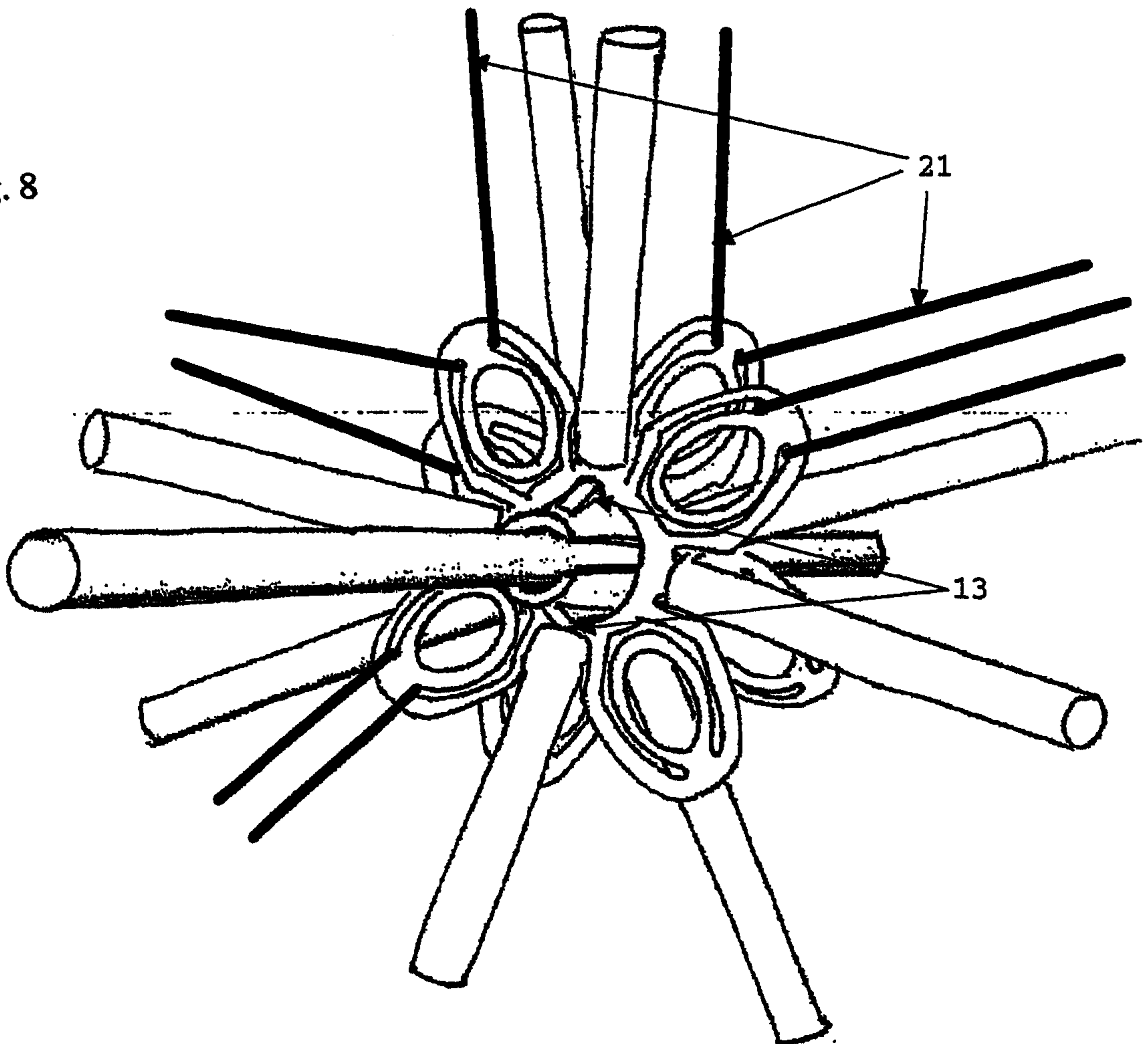

fig. 9

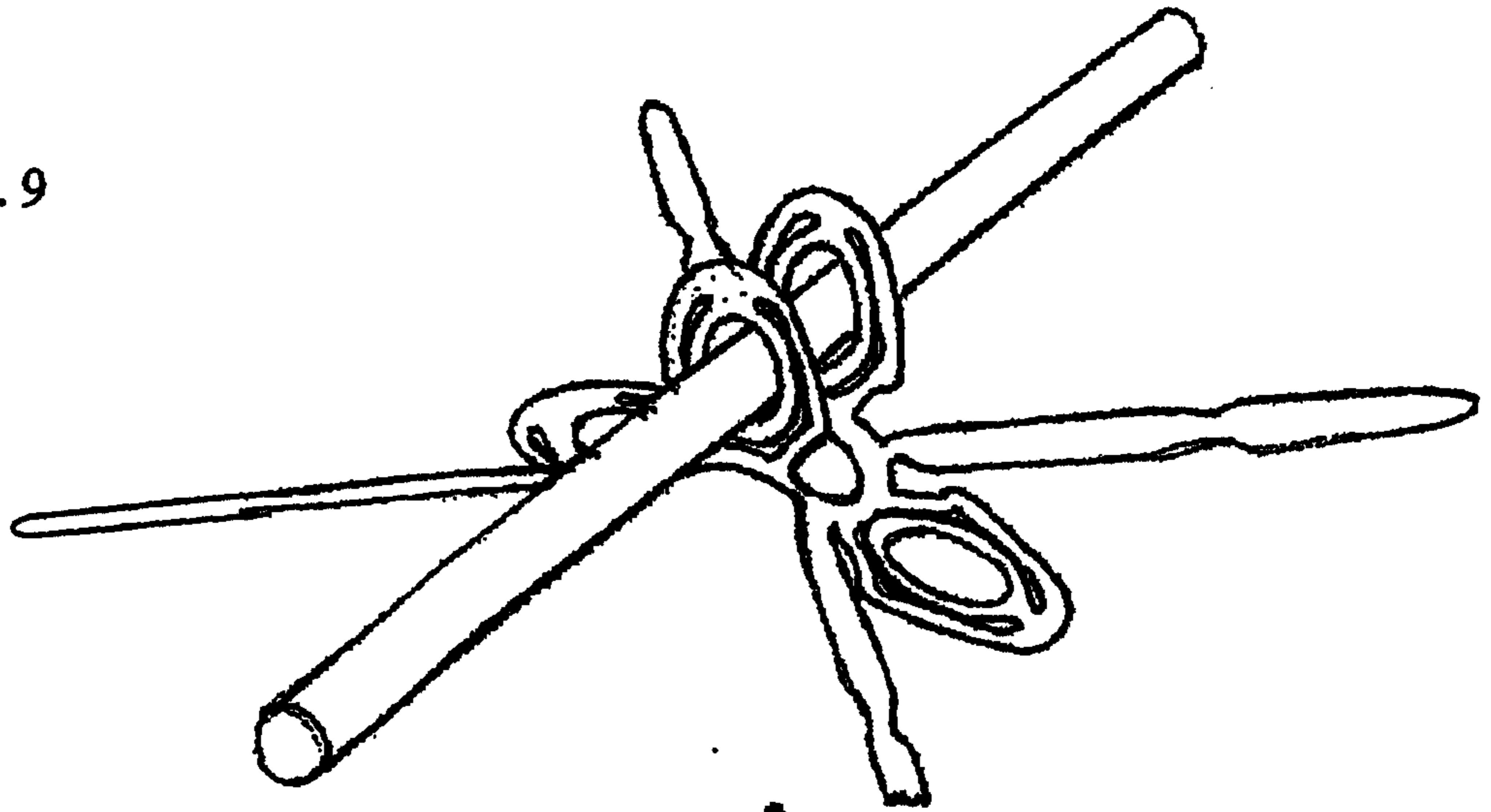

fig. 10

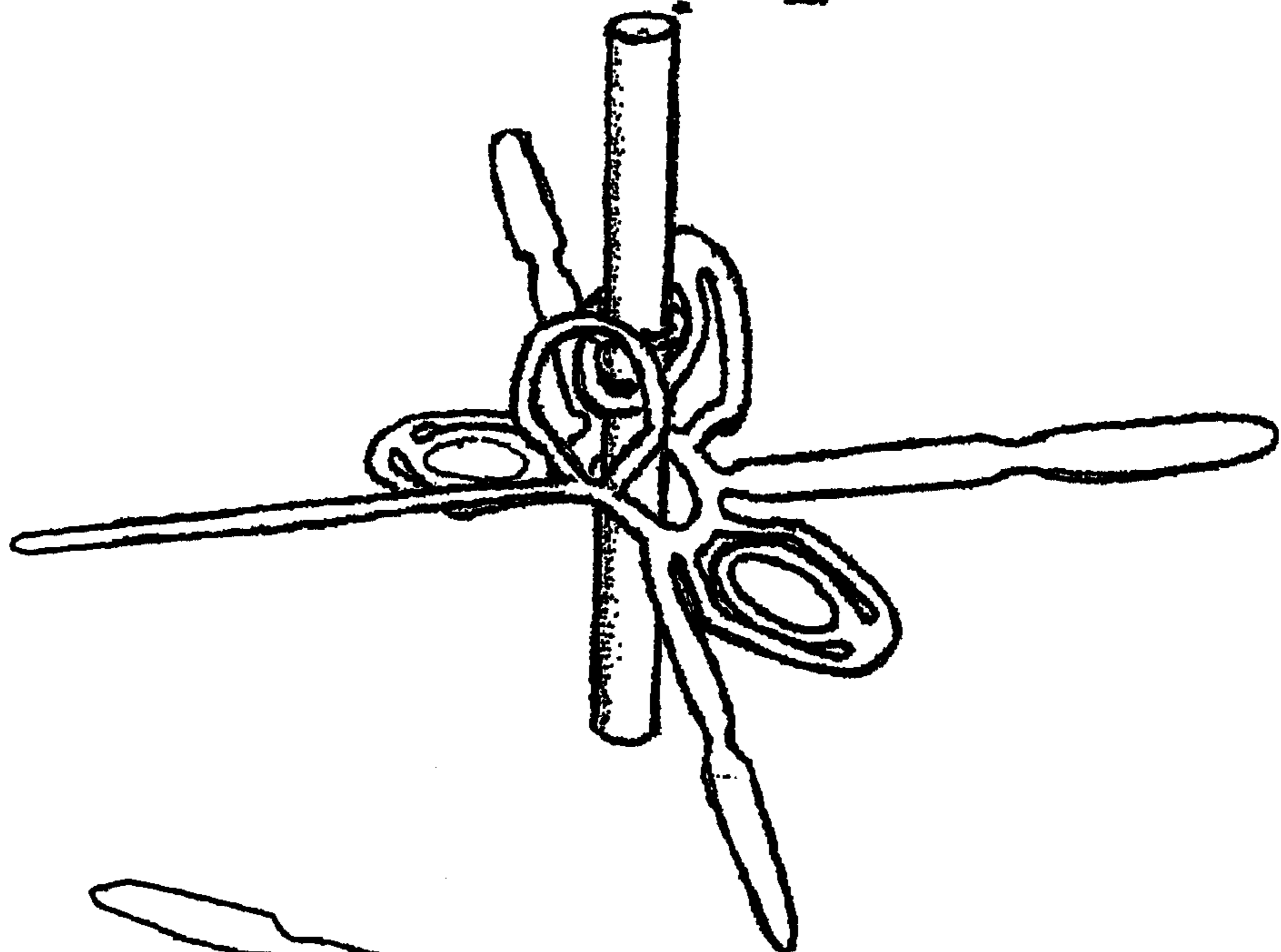

fig. 11

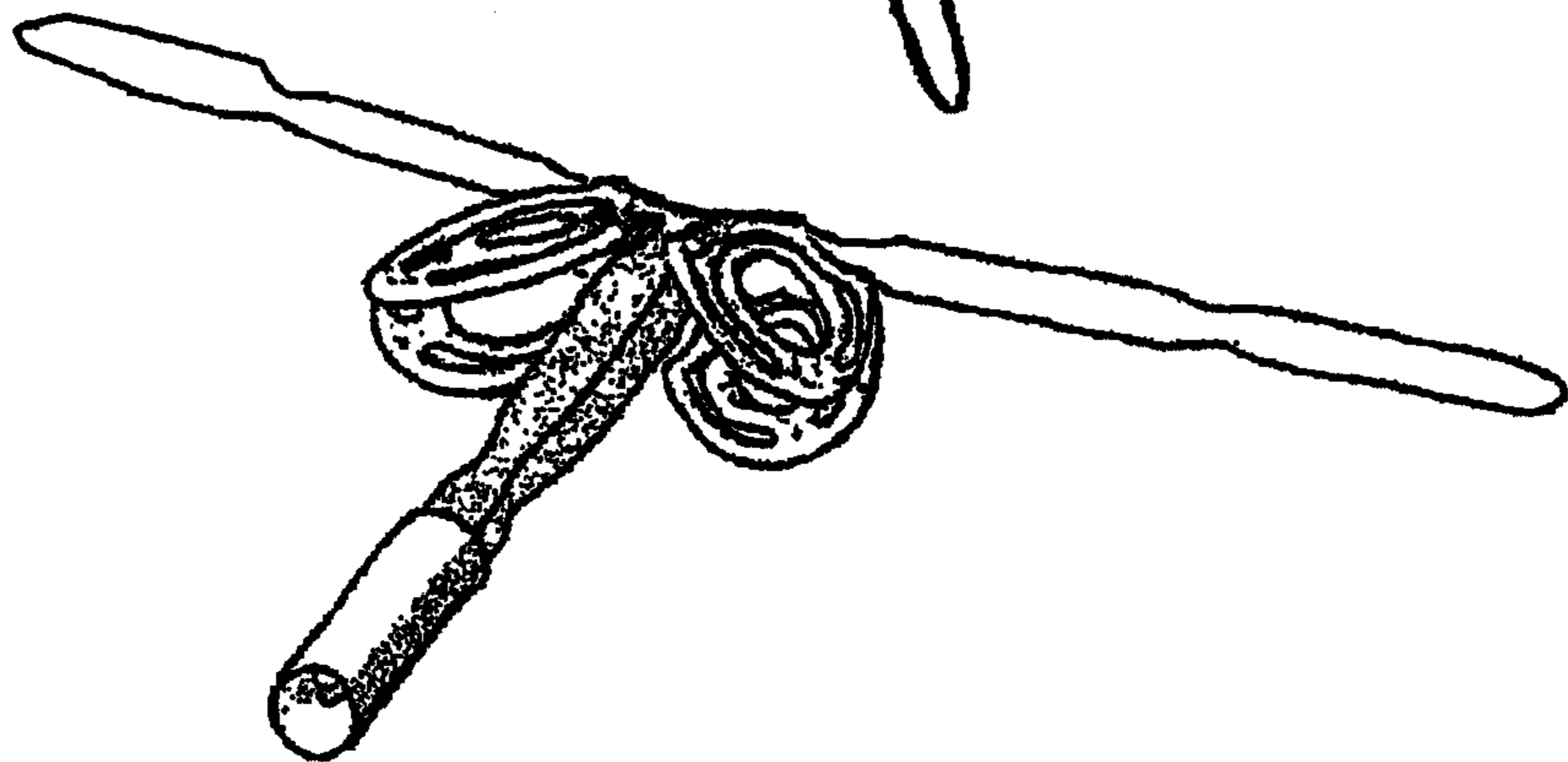

fig. 12

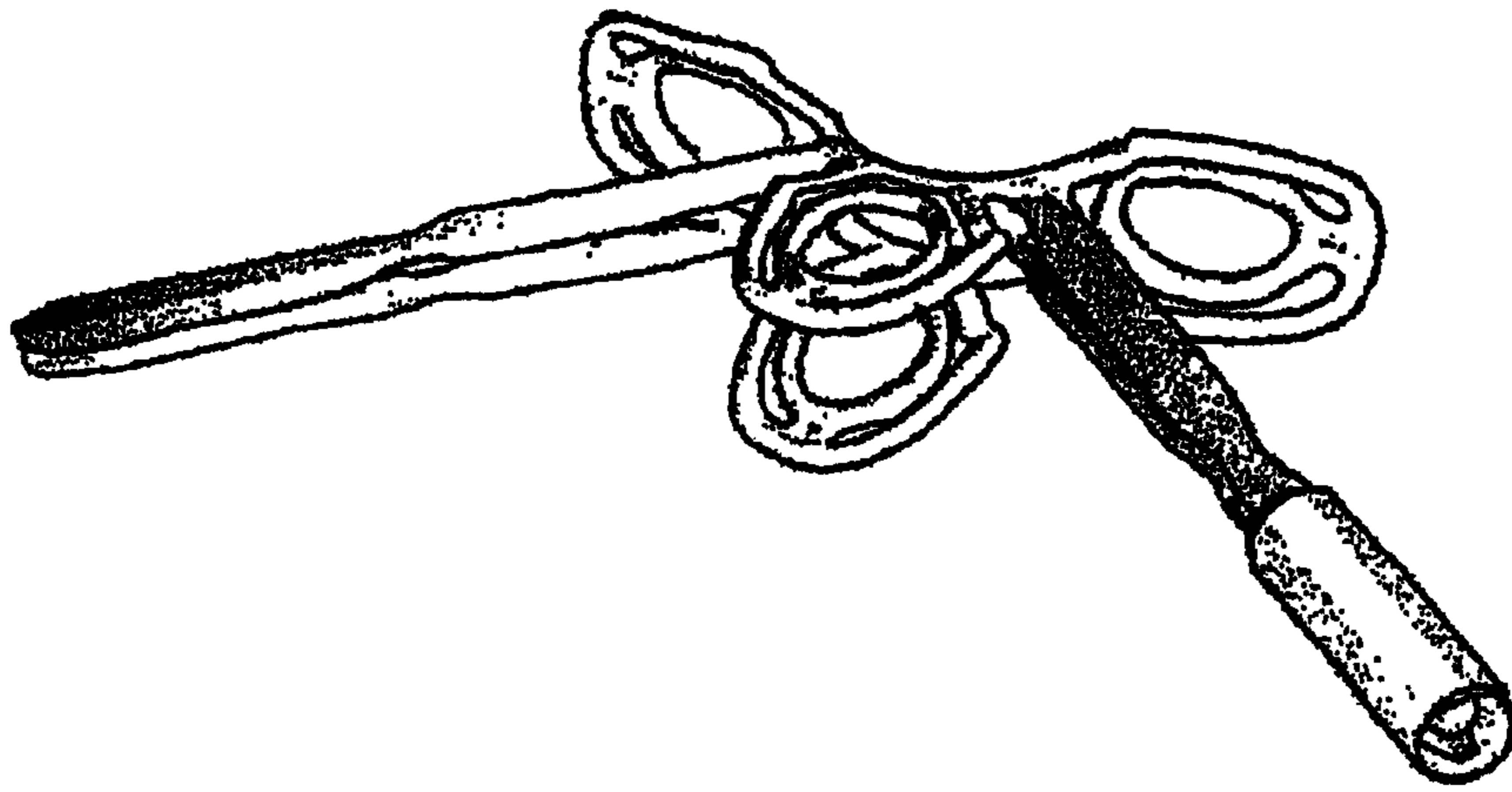

fig. 13

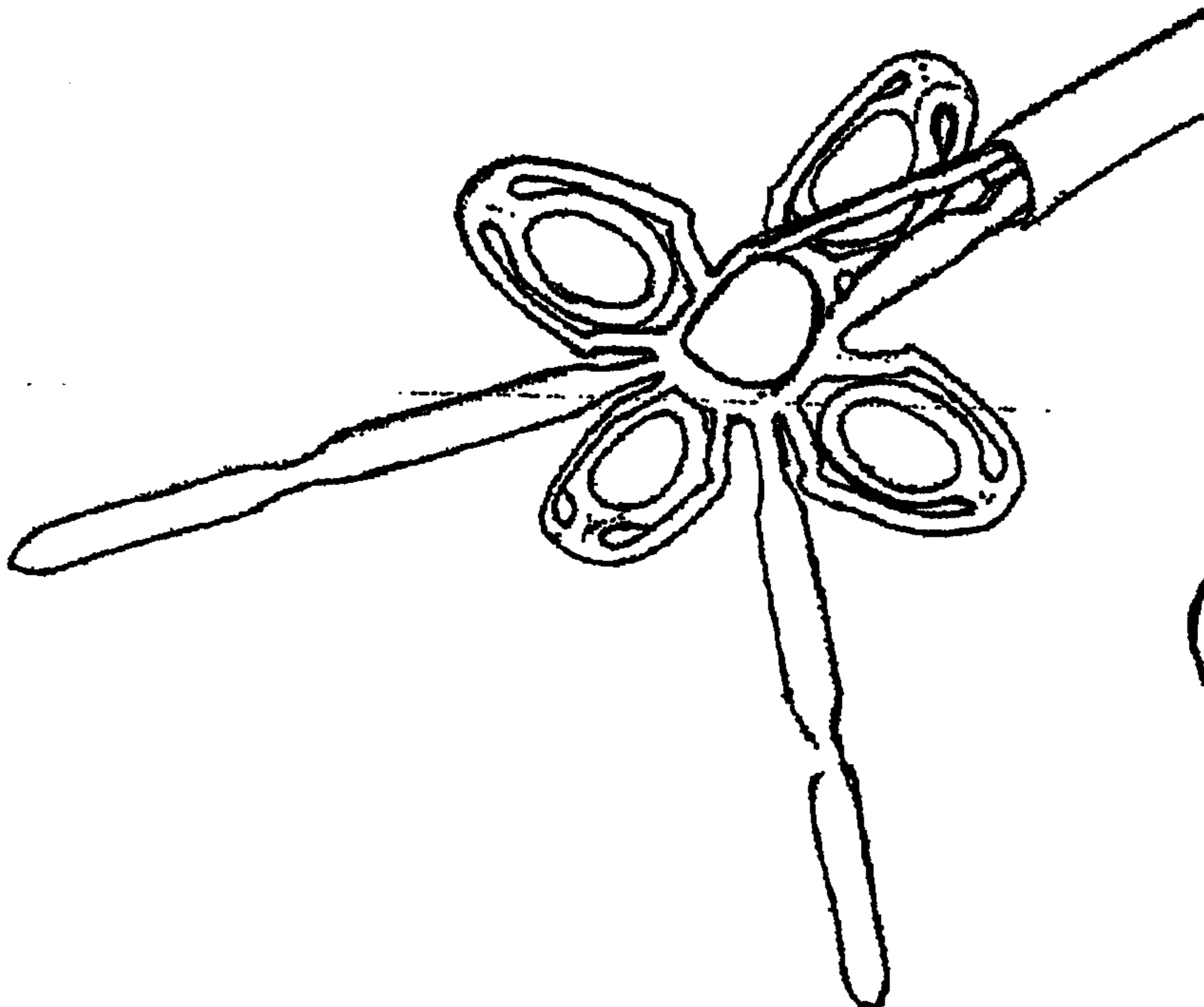

fig. 14

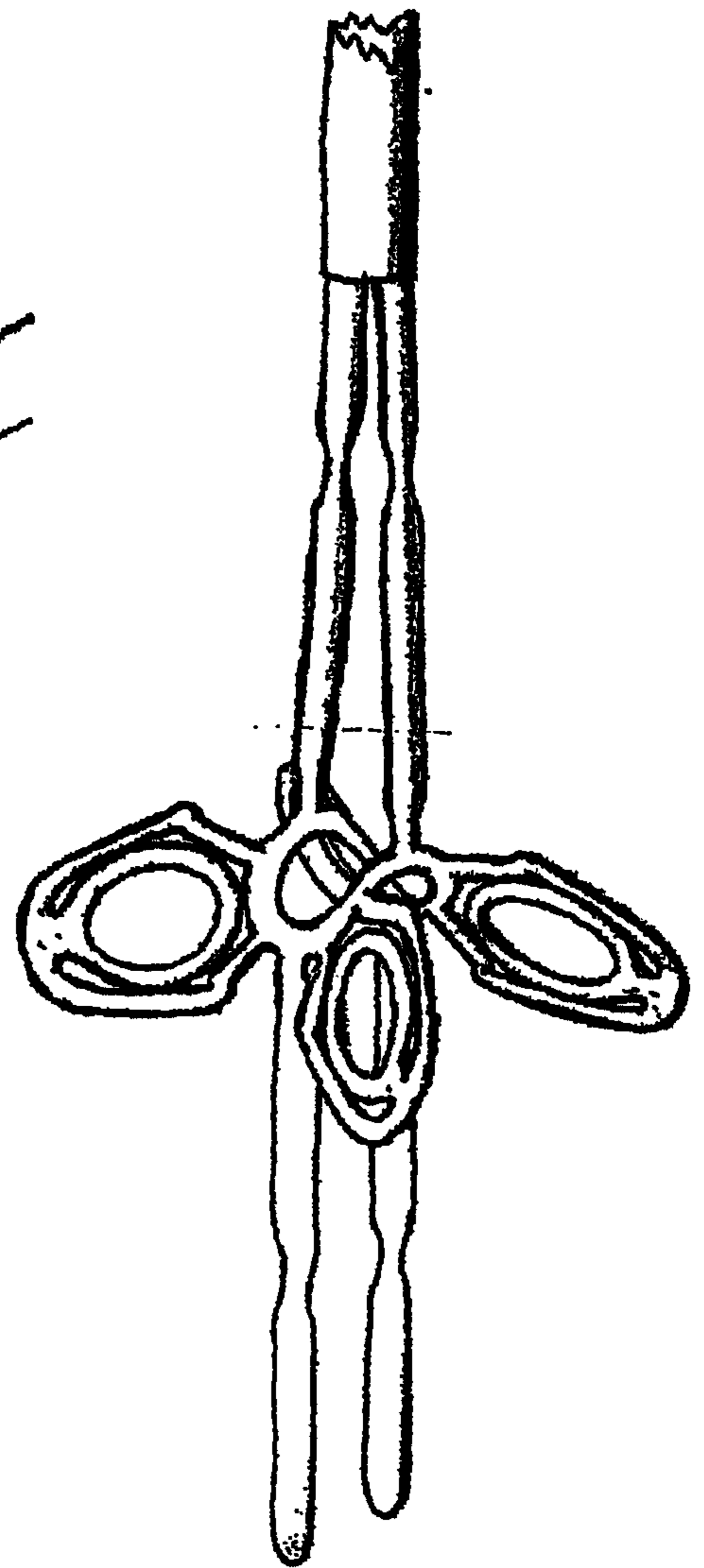

fig. 15

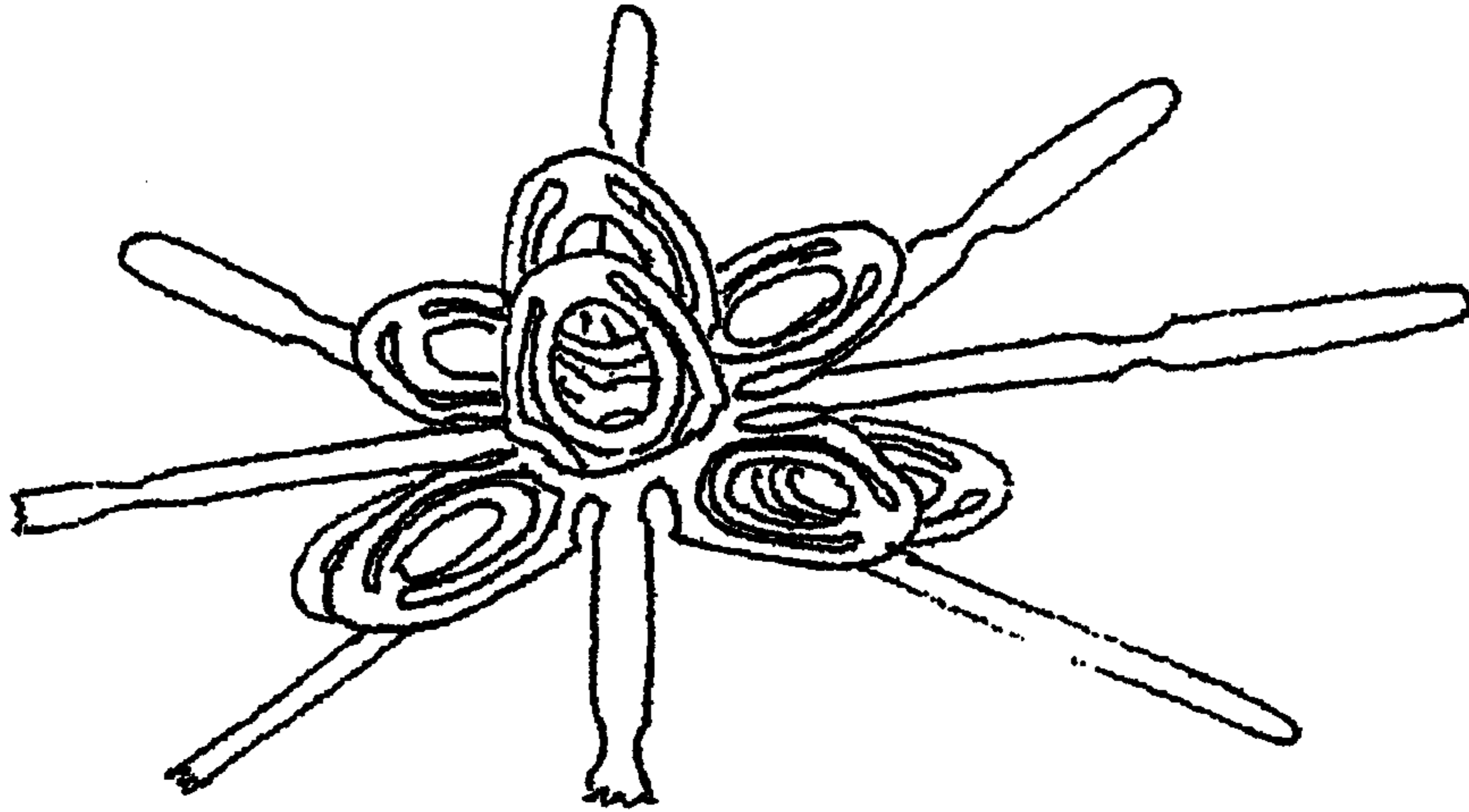

fig. 16

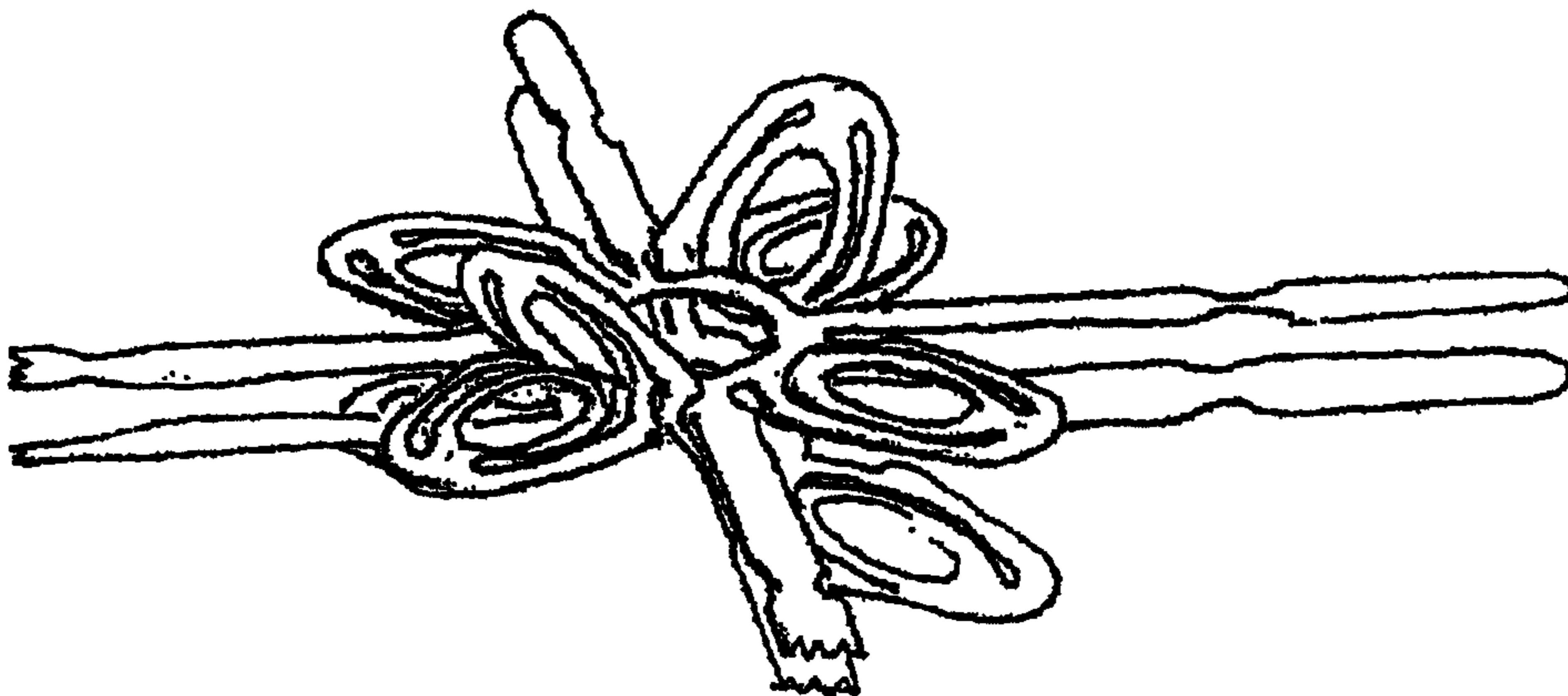

fig. 17

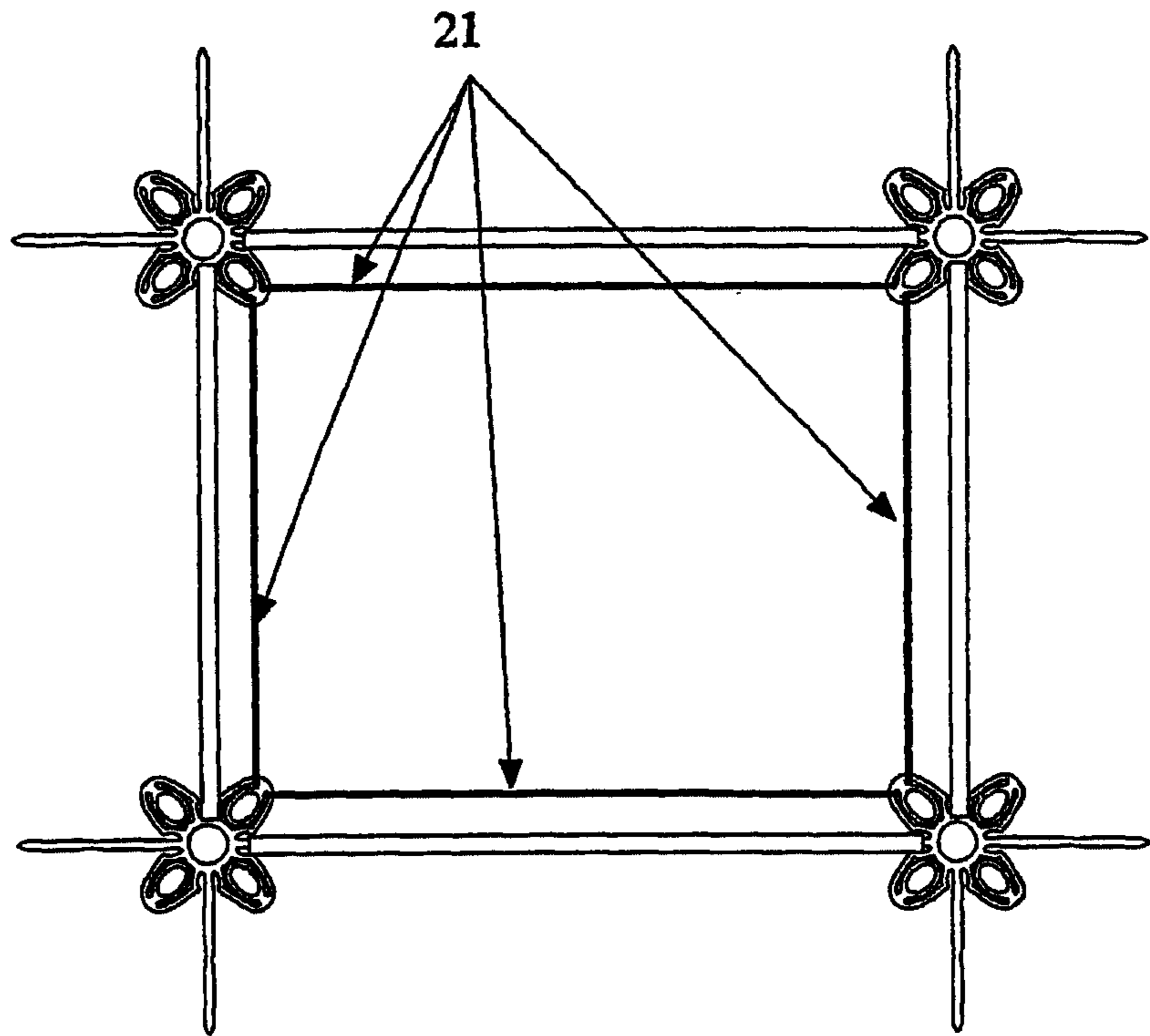

fig. 18

