

(19) World Intellectual Property Organization
International Bureau



(43) International Publication Date
10 February 2011 (10.02.2011)

PCT

(10) International Publication Number
WO 2011/017227 A2

- (51) International Patent Classification:
H02G 3/04 (2006.01)
- (21) International Application Number:
PCT/US2010/043959
- (22) International Filing Date:
30 July 2010 (30.07.2010)
- (25) Filing Language: English
- (26) Publication Language: English
- (30) Priority Data:
- | | | |
|------------|------------------------------|----|
| 61/231,714 | 6 August 2009 (06.08.2009) | US |
| 61/266,547 | 4 December 2009 (04.12.2009) | US |
| 61/354,519 | 14 June 2010 (14.06.2010) | US |
| 61/354,880 | 15 June 2010 (15.06.2010) | US |

(71) Applicant (for all designated States except US): **3M INNOVATIVE PROPERTIES COMPANY** [US/US]; 3M Center, Post Office Box 33427, Saint Paul, Minnesota 55133-3427 (US).

(72) Inventors; and

(75) Inventors/Applicants (for US only): **LARSON, Donald K.** [US/US]; 3M Center, Post Office Box 33427, Saint Paul, Minnesota 55133-3427 (US). **WILKES, Linnea M.** [US/US]; 3M Center, Post Office Box 33427, Saint Paul, Minnesota 55133-3427 (US). **BORER, Victor J.** [US/US]; 3M Center, Post Office Box 33427, Saint Paul, Minnesota 55133-3427 (US). **PETERSEN, Kurt H.** [US/US]; 8402 Ardash Lane, Austin, Texas 78759 (US).

RAIDER, Wesley A. [US/US]; 3M Center, Post Office Box 33427, Saint Paul, Minnesota 55133-3427 (US). **DOWER, William V.** [US/US]; 3M Center, Post Office Box 33427, Saint Paul, Minnesota 55133-3427 (US). **THOMPSON, Zachary M.** [US/US]; 3M Center, Post Office Box 33427, Saint Paul, Minnesota 55133-3427 (US). **TREADWELL, Daniel J.** [US/US]; 3M Center, Post Office Box 33427, Saint Paul, Minnesota 55133-3427 (US). **PARIKH, Rutesh D.** [US/US]; 3M Center, Post Office Box 33427, Saint Paul, Minnesota 55133-3427 (US). **ALLEN, William G.** [US/US]; 3M Center, Post Office Box 33427, Saint Paul, Minnesota 55133-3427 (US).

(74) Agents: **ROSENBLATT, Gregg H.** et al.; 3M Center, Office of Intellectual Property Counsel, Post Office Box 33427, Saint Paul, Minnesota 55133-3427 (US).

(81) Designated States (unless otherwise indicated, for every kind of national protection available): AE, AG, AL, AM, AO, AT, AU, AZ, BA, BB, BG, BH, BR, BW, BY, BZ, CA, CH, CL, CN, CO, CR, CU, CZ, DE, DK, DM, DO, DZ, EC, EE, EG, ES, FI, GB, GD, GE, GH, GM, GT, HN, HR, HU, ID, IL, IN, IS, JP, KE, KG, KM, KN, KP, KR, KZ, LA, LC, LK, LR, LS, LT, LU, LY, MA, MD, ME, MG, MK, MN, MW, MX, MY, MZ, NA, NG, NI, NO, NZ, OM, PE, PG, PH, PL, PT, RO, RS, RU, SC, SD, SE, SG, SK, SL, SM, ST, SV, SY, TH, TJ, TM, TN, TR, TT, TZ, UA, UG, US, UZ, VC, VN, ZA, ZM, ZW.

(84) Designated States (unless otherwise indicated, for every kind of regional protection available): ARIPO (BW, GH,

[Continued on next page]

(54) Title: ADHESIVE BACKED DUCTS FOR CABLING APPLICATIONS

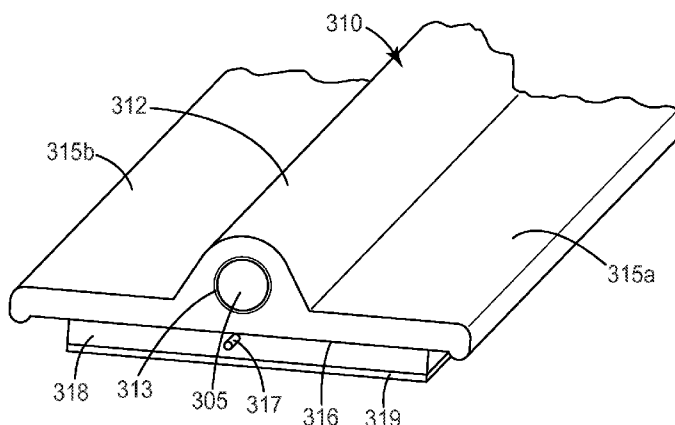

FIG. 1B

(57) Abstract: A duct for distributing one or more communication lines comprises an elongated body having a length and a conduit portion with a lengthwise bore formed therein, the conduit portion containing one or more communication lines. The duct also includes a flange extending lengthwise adjacent the elongated body to mount the duct to a mounting surface. The duct also includes an adhesive layer disposed on a bottom surface of the flange. The duct may further include a strength member extending lengthwise with the flange. The strength member may be disposed between the bottom surface and the adhesive layer or within the conduit. The duct may include an open slot in the top to allow for insertion and removal of the communication line. The duct may also be configured such that the conduit portion is attached to the flange structure via a thin web of material having a thickness such that upon modest application of a peeling force, a segment of the conduit portion is detachable from the flange structure.

WO 2011/017227 A2



GM, KE, LR, LS, MW, MZ, NA, SD, SL, SZ, TZ, UG, ZM, ZW), Eurasian (AM, AZ, BY, KG, KZ, MD, RU, TJ, TM), European (AL, AT, BE, BG, CH, CY, CZ, DE, DK, EE, ES, FI, FR, GB, GR, HR, HU, IE, IS, IT, LT, LU, LV, MC, MK, MT, NL, NO, PL, PT, RO, SE, SI, SK, SM, TR), OAPI (BF, BJ, CF, CG, CI, CM, GA, GN, GQ, GW, ML, MR, NE, SN, TD, TG).

— *as to applicant's entitlement to apply for and be granted a patent (Rule 4.17(ii))*

— *as to the applicant's entitlement to claim the priority of the earlier application (Rule 4.17(iii))*

Published:

— *without international search report and to be republished upon receipt of that report (Rule 48.2(g))*

Declarations under Rule 4.17:

ADHESIVE BACKED DUCTS FOR CABLING APPLICATIONS

BACKGROUND OF THE INVENTION

Field of the Invention

The present invention is directed to a duct having communications lines for
5 telecommunication cabling applications that includes a pressure sensitive adhesive layer.

Background

Several hundred million multiple dwelling units (MDUs) exist globally, which are
inhabited by about one third of the world's population. Due to the large concentration of
tenants in one MDU, Fiber-to-the-X ("FTTX") deployments to these structures are more
10 cost effective to service providers than deployments to single-family homes. Connecting
existing MDUs to the FTTX network can often be difficult. Challenges can include
gaining building access, limited distribution space in riser closets, and space for cable
routing and management. Specifically, FTTX deployments within existing structures
make it difficult to route cables within the walls or floors, or above the ceiling from a
15 central closet or stairwell, to each living unit.

Conventionally, a service provider installs an enclosure (also known as a fiber
distribution terminal (FDT)) on each floor, or every few floors, of an MDU. The FDT
connects the building riser cable to the horizontal drop cables which run to each living unit
on a floor. Drop cables are spliced or otherwise connected to the riser cable in the FDT
20 only as service is requested from a tenant in a living unit. These service installations
require multiple re-entries to the enclosure, putting at risk the security and disruption of
service to other tenants on the floor. This process also increases the service provider's
capital and operating costs, as this type of connection requires the use of an expensive
fusion splice machine and highly skilled labor. Routing and splicing individual drop
25 cables can take an excessive amount of time, delaying the number of subscribers a
technician can activate in one day, reducing revenues for the service provider.

Alternatively, service providers install home run cabling the full extended length from
each living unit in an MDU directly to a fiber distribution hub (FDH) in the building vault,
therefore encompassing both the horizontal and riser with a single extended drop cable.
30 This approach creates several challenges, including the necessity of first installing a

pathway to manage, protect and hide each of the multiple drop cables. This pathway often includes very large (e.g., 2 inch to 4 inch to 6 inch) pre-fabricated crown molding made of wood, composite, or plastic. Many of these pathways, over time, become congested and disorganized, increasing the risk of service disruption due to fiber bends and excessive re-
5 entry.

In addition, further physical and aesthetic challenges exist in providing the final drop to and from each individual living unit. Also, because of their size, many conventional indoor optical network terminals (ONTs) are often placed in the closets of living units out of normal view. This type of arrangement requires that a service provider
10 run new cabling (such as coaxial cables, cat 5 cables, and others) from the closet to the existing wiring in the living unit to activate the ONT to provide service. As newer ONTs have become smaller in physical size, they can be placed outside of closets and into main living areas.

SUMMARY

15 According to an exemplary aspect of the present invention, a duct for distributing one or more communication lines comprises an elongated body having a length and a conduit portion with a lengthwise bore formed therein, the conduit portion containing one or more communication lines. The duct also includes a flange extending lengthwise adjacent the elongated body to mount the duct to a mounting surface. The duct also
20 includes an adhesive layer disposed on a bottom surface of the flange. The duct further includes a strength member extending lengthwise with the flange and disposed between the bottom surface and the adhesive layer.

According to another exemplary aspect of the present invention, a duct for
25 distributing one or more communication lines comprises an elongated body having a length and a conduit portion with a lengthwise bore formed therein, the conduit portion containing one or more communication lines. The duct also includes a flange extending lengthwise adjacent the elongated body to mount the duct to a mounting surface. The duct also includes an adhesive layer disposed on a bottom surface of the flange. The duct
30 further includes a strength member extending lengthwise with the flange and disposed within the conduit portion.

In another aspect, the strength member comprises an aramid string. In another aspect, the strength member comprises an aramid yarn. In another aspect, the strength member comprises a bonded material.

5 In yet another aspect, the strength member is disposed centrally with respect to a width of the duct.

In another aspect, the conduit portion is attached to the flange structure via a thin web of material having a thickness such that upon modest application of a peeling force, a segment of the conduit portion is detachable from the flange structure.

10 In another aspect, the conduit portion includes a longitudinal slot formed therein to provide for insertion and removal of the at least one communication line.

In another aspect, the duct includes at least one additional conduit portion, wherein the first conduit portion is configured to contain at least a first communication line and the additional conduit portion is configured to contain at least a second communication line.

15 According to another exemplary aspect of the present invention, a duct for distributing one or more communication lines comprises a flexible, elongated body having a plurality of conduit portions, each conduit portion having a lengthwise bore formed therein and configured to house an individual communication line. The duct also includes a flange structure extending lengthwise adjacent the elongated body to mount the duct to a mounting surface. The duct also includes a pressure sensitive adhesive layer disposed on a
20 generally flat bottom surface of the flange structure, wherein the conduit portions are disposed adjacent each other in the same plane on an upper surface of the flange structure.

25 According to another exemplary aspect of the present invention, a duct for distributing one or more communication lines comprises a flexible, elongated body having a conduit portion with a lengthwise bore formed therein, the conduit portion containing one or more communication lines. The duct also includes a flange structure extending lengthwise adjacent the elongated body to mount the duct to a mounting surface. The duct also includes a pressure sensitive adhesive layer disposed on a generally flat bottom surface of the flange structure, wherein the conduit portion includes a longitudinal slot formed therein to provide for insertion and removal of the at least one communication line.

30 In another aspect, the slot has a size of about 50% or less of a diameter of the at least one communication line. In yet another aspect, the slot has a size of from about 10% to about 50% of the communication line outer diameter.

In another aspect, the duct includes multiple conduits each having a bore formed along a longitudinal axis of the duct, wherein a first conduit is configured to hold a first drop fiber and a second conduit is configured to hold a second drop fiber.

According to another exemplary aspect of the present invention, a duct for
5 distributing one or more communication lines comprises a flexible, elongated body having a conduit portion with a lengthwise bore formed therein, the conduit portion containing one or more communication lines. The duct also includes a flange structure extending lengthwise adjacent the elongated body to mount the duct to a mounting surface. The duct also includes a pressure sensitive adhesive layer disposed on a generally flat bottom
10 surface of the flange structure, wherein the conduit portion is attached to the flange structure via a thin web of material having a thickness such that upon modest application of a peeling force, a segment of the conduit portion is detachable from the flange structure.

In another aspect, the conduit portion is formed in the same bending plane as the flange structure.

15 In another aspect, the thin web of material has a thickness of from about 10% to about 30% of the thickness of the flange structure.

In another aspect, the conduit portion is attached to a central portion of the flange structure.

In another aspect, the conduit portion comprises dual conduit portions having the
20 flange structure disposed in between, each of the conduit portions attached to the flange structure via a thin web of material, wherein the conduit portions are formed in the same bending plane as the flange structure.

In another aspect, the conduit portion comprises multiple conduit portions, each attached to a top surface of the flange structure via a thin web of material.

25 In another aspect, the adhesive layer comprises a stretch release adhesive. In another aspect, the adhesive layer comprises a double sided tape. In another aspect, the adhesive layer comprises a transfer adhesive.

In another aspect, the adhesive layer further includes a liner that is removable prior to mounting the duct on a mounting surface.

30 In another aspect, the elongated body has a form factor (length versus width) of greater than 100 to 1.

In another aspect, the duct includes at least one additional conduit, wherein the first conduit is configured to contain at least a first optical fiber communication line and the additional conduit is configured to contain at least a second optical fiber communication line.

5 In another aspect, the one or more communication lines include an electrical wire.

In another aspect, the one or more communication lines include a plastic optical fiber. In yet another aspect, the one or more communication lines include a single mode optical fiber. In yet another aspect, the one or more communication lines include a multi-mode optical fiber. In yet another aspect, the one or more communication lines comprises
10 a micro-module that includes a plurality of optical fibers.

According to another exemplary aspect of the present invention, a duct for distributing one or more communication lines comprises a flexible, elongated body having a conduit portion with a lengthwise bore formed therein, the conduit portion containing one or more communication lines. The duct also includes a flange structure extending
15 lengthwise adjacent the elongated body to mount the duct to a mounting surface. The duct also includes a pressure sensitive adhesive layer disposed on a generally flat bottom surface of the flange structure, wherein the duct is formed from an extruded polymeric material having chopped strength members mixed therein.

According to another exemplary aspect of the present invention, a tape for
20 distributing one or more communication lines within a living unit, comprises an optically clear or translucent pressure sensitive adhesive tape, having a communication line with a clear buffer coating, mountable to a wall within the living unit, wherein the communication line is disposed between an adhesive portion of the optically clear or translucent adhesive tape and the wall.

25 In another aspect, a drop access system for installation in a building comprises the above described duct or tape.

In another aspect, a system for providing a final drop that is installed in a living unit comprises the above described duct or tape.

The above summary of the present invention is not intended to describe each
30 illustrated embodiment or every implementation of the present invention. The figures and the detailed description that follows more particularly exemplify these embodiments.

BRIEF DESCRIPTION OF THE DRAWINGS

The present invention will be further described with reference to the accompanying drawings, wherein:

5 Fig. 1A is an isometric view of an exemplary duct according to a first aspect of the invention.

Fig. 1B is an isometric view of another exemplary duct according to another aspect of the invention.

Fig. 1C is an isometric view of another exemplary duct according to another aspect of the invention.

10 Fig. 1D is an isometric view of another exemplary duct according to another aspect of the invention.

Fig. 1E is an isometric view of another exemplary duct according to another aspect of the invention.

15 Fig. 1F is an isometric view of another exemplary duct according to another aspect of the invention.

Fig. 2 is a schematic view of an exemplary lamination process utilized to make an exemplary duct according to an aspect of the invention.

20 Fig. 3 is a schematic view of an exemplary MDU having a drop access location system and a final drop system utilizing the exemplary duct according to another aspect of the present invention.

Fig. 4 is a schematic view of an exemplary final drop system utilizing the exemplary duct according to another aspect of the present invention.

25 Fig. 5A is an isometric view of another exemplary duct according to another aspect of the invention.

Fig. 5B is an isometric view of another exemplary duct according to another aspect of the invention.

Fig. 5C is an isometric view of another exemplary duct according to another aspect of the invention.

30 Fig. 5D is an isometric view of another exemplary duct according to another aspect of the invention.

Fig. 5E is an isometric view of another exemplary duct according to another aspect of the invention.

Fig. 6A is an isometric view of another exemplary duct according to another aspect of the invention.

Fig. 6B is an isometric view of another exemplary duct according to another aspect of the invention.

5 Fig. 7A is an isometric view of another exemplary duct according to another aspect of the invention.

Fig. 7B is an isometric view of another exemplary duct according to another aspect of the invention.

10 Fig. 7C is an isometric view of another exemplary duct according to another aspect of the invention.

Fig. 8A is an isometric view of another exemplary duct according to another aspect of the invention.

Fig. 8B is a top view of the exemplary duct of Fig. 8A having a right angle, in-plane bend.

15 Fig. 8C is an isometric view of another exemplary duct according to another aspect of the invention.

Fig. 8D is a top view of the exemplary duct of Fig. 8C having a right angle, in-plane bend.

20 Fig. 9A is an isometric view of another exemplary duct according to another aspect of the invention.

Fig. 9B is a top view of the exemplary duct of Fig. 9A having a right angle, in-plane bend.

While the invention is amenable to various modifications and alternative forms, specifics thereof have been shown by way of example in the drawings and will be described in detail. It should be understood, however, that the intention is not to limit the invention to the particular embodiments described. On the contrary, the intention is to cover all modifications, equivalents, and alternatives falling within the scope of the invention as defined by the appended claims.

DETAILED DESCRIPTION OF THE EMBODIMENTS

30 In the following Detailed Description, reference is made to the accompanying drawings, which form a part hereof, and in which is shown by way of illustration specific embodiments in which the invention may be practiced. In this regard, directional

terminology, such as “top,” “bottom,” “front,” “back,” “leading,” “forward,” “trailing,” etc., is used with reference to the orientation of the Figure(s) being described. Because components of embodiments of the present invention can be positioned in a number of different orientations, the directional terminology is used for purposes of illustration and is in no way limiting. It is to be understood that other embodiments may be utilized and structural or logical changes may be made without departing from the scope of the present invention. The following detailed description, therefore, is not to be taken in a limiting sense, and the scope of the present invention is defined by the appended claims.

The present invention is directed to an adhesive-backed duct for distributing one or more communication lines for communication and wiring applications in a premise or building, such as an MDU (which for purposes of this application can include a typical MDU, multiple tenant unit (MTU), office building, school, hotel, hospital or other location) or another facility. The duct includes at least one conduit portion with a bore formed therein for accommodating one or more communication lines that can include optical fiber, electrical wiring, or a combination thereof. The duct further includes a flange structure and an adhesive layer disposed on a bottom surface of the flange structure which allows an installer or the service provider to mount the duct to a mounting surface, such as a wall, in a straightforward manner. The various ducts described herein provide communication lines that can be used to connect with telecommunication drop lines from individual living units, such as residences, classrooms, or offices, within the MDU or other building and/or to provide a final drop within the living unit in an MDU or other building. The ducts described herein can provide a low impact profile for better aesthetics. For example, the ducts can be installed on the walls of a corridor or hallway in an existing building to provide new communications wiring to individual residences and offices and/or within the individual residences and offices. The term “living unit” is not limited to a domicile or residence, but can include an office, conference room, hotel room, hospital room, school room or other similar room, whether or not continuously occupied.

In a preferred aspect, the adhesive-backed duct includes a pressure sensitive adhesive layer. In some aspects, the adhesive-backed duct further includes a strength member that runs lengthwise with the duct. In some aspects, the strength member is disposed in the conduit portion. In other aspects, the strength member is included in a separate channel in the duct. In other aspects, the strength member is disposed between

the adhesive layer and the bottom surface of the flange structure. The strength member can help prevent elongation and relaxation of the duct during and after installation, where such elongation and relaxation may cause disbondment of the duct from the mounting surface. The duct may include an open slot in the top to allow for insertion and removal of the communication line. The duct may also be configured such that the conduit portion is attached to the flange structure via a thin web of material having a thickness such that upon modest application of a peeling force, a segment of the conduit portion is detachable from the flange structure.

In more detail, a close-up isometric view of a first exemplary duct 110 is shown in Fig. 1A. Duct 110 includes a main body having a conduit portion 112 with a bore 113 provided therethrough. The bore is sized to accommodate one or more communications lines disposed therein. In a preferred aspect, in use, the duct 110 comprises one or more communications lines, such as optical fibers. In use, the duct 110 can be pre-populated with one or more communications lines. In addition, duct 110 may also be populated with at least one electrical power line. While conduit portion 112 can have a generally circular cross-section, in alternative embodiments it may have another shape, such as a rectangle, square, triangle, oval, or other polygonal shaped cross-section.

Duct 110 is an elongated structure that may have a length (L) of up to several tens of meters (depending on the application), while the width (W) is about 5 mm to about 50 mm. Thus, in a preferred aspect, the duct can have a shape or form factor (L vs. W) of at least an order of magnitude, and in many applications, the duct can have a form factor of at least about 25 to 1, a form factor of at least about 50 to 1, or a form factor of at least 100 to 1. As the duct described herein can be supplied to the installer in mass spooled form, the length of the duct is limited only by logistical constraints.

In one aspect, duct 110 is a structure formed from a polymeric material, such as a polyolefin, a polyurethane, a polyvinyl chloride (PVC), or the like. For example, in one aspect, duct 110 can comprise an exemplary material such as a polyurethane elastomer, e.g., Elastollan 1185A10FHF (available from BASF, Florham Park, NJ). Additives, such as flame retardants, stabilizers, and fillers can also be incorporated as required for a particular application. In a preferred aspect, duct 110 is flexible, so that it can be guided and bent around corners and other structures without cracking or splitting. Duct 110 can be continuously formed using a conventional extrusion process.

In a preferred aspect, the duct 110 can be provided to the installer without a slit. In an alternative aspect, duct 110 can further include a slit (not shown) that runs the longitudinal length of the duct. The slit can provide access for inserting or removing the fiber and may be positioned at a selected position (e.g., base, top or middle) on the conduit portion. In a further alternative aspect, the slit can be formed within overlapping wall surfaces of the conduit to ensure the communications line(s) is/are properly restrained within the conduit portion. In a further alternative aspect, the conduit portion 112 can be directly extruded over the communications line(s) in an over-jacket extrusion process.

Duct 110 also includes a flange structure or similar flattened portion to provide support for the duct 110 as it is installed on or mounted to a wall or other mounting surface, such as a floor, ceiling, or molding. In most applications, the mounting surface is generally flat. The mounting surface may have texture or other structures formed thereon. In other applications, the mounting surface may have curvature, such as found with a pillar or column. The flange structure extends along the longitudinal axis of the duct as shown in Fig. 1A. Exemplary duct 110 includes a double flange structure, with flange portions 115a and 115b, positioned (in use) below the centrally positioned conduit portion. In an alternative aspect, the flange structure can include a single flange portion. In alternative applications, a portion of the flange structure can be removed for in-plane and out-of-plane bending.

In a preferred aspect, the flange 115a, 115b includes a rear or bottom surface 116 that has a generally flat surface shape. This flat surface provides a suitable surface area for adhering the duct 110 to a mounting surface, a wall or other surface (e.g., dry wall or other conventional building material) using an adhesive layer 118.

In some preferred embodiments, duct 110 can include a strength member 117. Strength member 117 comprises a material, such as an aramid string or thread (e.g., a woven or non-woven Kevlar™ material) that is twisted or aramid yarn. The aramid string or aramid yarn can be bonded or un-bonded. Alternative strength member materials include metallic wire or a fiberglass member. The strength member 117 runs lengthwise with the main body of duct 110 and is disposed between the bottom surface 116 (of the duct's main body and/or flange 115a/115b) and an adhesive layer 118. In one aspect, the strength member 117 is disposed centrally (with respect to the duct's width). In alternative aspects, the strength member 117 may be disposed closer to one side of the

duct than the other side (e.g., directly between flange 115a and adhesive layer 118 or between flange 115b and adhesive layer 118).

In other aspects, the strength member can be located in the bore of the conduit portion with the communication line(s). In a further alternative aspect, the duct (e.g., duct
5 110 or others described herein) can comprise an extruded polymer material, such as those described above, that is loaded or mixed with cut-up or chopped strength member (e.g., aramid) pieces to provide against excessive localized stretching during the application process.

As described further below, the strength member(s) can help prevent elongation
10 and relaxation of the duct during and after installation, where such elongation and relaxation may cause disbondment of the duct from the mounting surface.

In a preferred aspect of the present invention, the adhesive layer 118 comprises a pressure sensitive adhesive, such as a transfer adhesive or double-sided tape, disposed on all or at least part of surface 116. These types of adhesives do not exhibit macroscopic
15 flow behavior upon application to a mounting surface and thus do not substantially change dimensions upon application to the mounting surface. In this manner, the aesthetic quality of the applied duct is maintained.

In one aspect, adhesive layer 118 comprises a factory applied 3M™ VHB™ Tape 4941F (available from 3M Company, St. Paul MN). In another aspect, adhesive layer 118
20 comprises a removable adhesive, such as a stretch release adhesive. By “removable adhesive” it is meant that the duct 110 can be mounted to a mounting surface (preferably, a generally flat surface, although some surface texture and/or curvature are contemplated) so that the duct 110 remains in its mounted state until acted upon by an installer/user to remove the duct from its mounted position. Even though the duct is removable, the
25 adhesive is suitable for those applications where the user intends for the duct to remain in place for an extended period of time. Suitable removable adhesives are described in more detail in U.S. Patent Appl. No. 61/324,147, incorporated by reference herein in its entirety.

In an alternative aspect, the adhesive layer 118 can comprise an epoxy adhesive.

In one alternative aspect, bottom surface 116 comprises an adhesive-lined surface
30 with a removable liner 119. In use, the liner 119 can be removed and the adhesive layer can be applied to a mounting surface.

One or more communication lines can be disposed within duct 110 for accessing and connecting to one or more drop wires or drop fibers of a particular living unit or as the communication line(s) within a living unit. The communication line(s) can be accessed either through a separate window cut made to the conduit portion of the duct or through a slit already formed in duct 110, depending on the particular configuration of the duct. The communication line(s) can comprise optical fibers, electrical wires, coaxial/micro-coaxial cable, or a combination of these, for data, video, audio, and/or telephone signal transmission. In one aspect, the communication lines can comprise discrete (loose) or ribbonized fiber. In another aspect, the optical fiber(s) can comprise single mode or multimode optical fibers (with 50 μm , 62.5 μm , 80 μm , or other, diameter cores). In another alternative application, the optical fiber(s) can comprise a plastic optical fiber. In another alternative application, the communication line can comprise one or more Cat 5/Cat 6 (shielded or unshielded) lines.

In one aspect, the communication line comprises a tight bend radius, 900 μm buffered optical fiber. Such an optical fiber cable is commercially available as DrakaEliteTM BendBright Elite or BendBright XS Single Mode Optical Fiber, from Draka Communications. In another aspect, a 250 μm optical fiber can be utilized. Also, an exemplary drop cable can comprise a 2.9 mm jacketed drop cable commercially available as ez PatchTM cabling and ez DropTM cabling from Draka Communications. In another alternative aspect, the exemplary drop cable can comprise a micro-module, such as is commercially available from Acome, that includes a plurality, e.g., four, 250 μm fibers disposed in a tube that allows for management of the multiple fibers together, but with access to the individual fibers as well.

A coupling or adapter can be used to connect the telecommunications line to a drop fiber cable. In an exemplary aspect, the telecommunications fiber is field terminated with an optical fiber connector, such as described in US Patent No. 7,369,738. Other optical fiber connectors, such as SC-APC, SC-UPC, LC, or MTP/MPO, can be utilized.

The drop cable from the individual living unit can be a conventional fiber cable such as a 2.9 mm jacketed fiber cable (e.g., an ez Drop Cable, available from Draka Communications) or blown fiber cabling (containing multiple discrete buffered fibers). The drop cable can be run in either direction (i.e., to or from a living unit), and can (or not) be pre-connectorized at one or two ends (e.g., a pre-connectorized pigtail of 2.9 mm jacket

cable). A drop fiber cable can be terminated on one end at an optical network terminal (ONT), such as a single family unit optical network terminal (SFU ONT) or wall box (e.g., a 7342 Indoor Optical Terminal, available from Alcatel-Lucent, Murray Hill, NJ).

Fig. 1B shows an isometric view of another exemplary duct 310, which includes a
5 conduit portion 312 having a bore 313 extending longitudinally therethrough. The bore
313 is sized to accommodate one or more communication lines disposed therein. In a
preferred aspect, the duct 310 comprises one or two communication lines, such as buffer
coated optical fibers, such as optical fiber 305. In use, the duct 310 can be pre-populated
with one or more communication lines. Alternatively, duct 310 may also be populated
10 with at least one electrical power line. While conduit portion 312 can have a generally
circular cross-section, in alternative embodiments it may have another shape, such as a
rectangle, square, triangle, oval, or other polygonal shaped cross-section.

Duct 310 is an elongated structure that may have a length (L) of up to several tens
of meters (depending on the application). Duct 310 can have a relatively compact cross-
15 section shape, with a lateral dimension from about 5 mm to about 30 mm, and a height of
less than about 2 mm to about 10 mm. Thus, in a preferred aspect, the duct can have a
shape or form factor (L vs. W) of at least an order of magnitude, and in many applications,
a form factor of about at least 100 to 1.

In one aspect, duct 310 is a continuous structure formed from a polymeric material
20 such as polyvinyl chloride (PVC), making it flexible, flame retardant and robust. In one
aspect, duct 310 can comprise an exemplary material such as a polyurethane elastomer,
e.g., Elastollan 1185A10FHF. In one aspect, duct 310 can comprise a polyolefin material
that optionally includes one or more flame retardant additives. As such, duct 310 can be
guided and bent around corners and other structures without cracking or splitting. Duct
25 310 can be continuously formed using a conventional extrusion process.

Optionally, duct 310 can further include a slit (not shown) that runs the
longitudinal length of the duct to provide access for inserting or removing the fiber(s).

Duct 310 also includes a generally flat flange structure having a first flange 315a
and a second flange 315b extending laterally from the conduit portion to provide support
30 for the duct 310 as it is adhered to a wall or other generally flat surface, such as a wall,
floor, ceiling, or molding. In this aspect, the flange structure extends along the
longitudinal axis of the duct and extends outward (in a wing shape) in both lateral

directions. In this aspect, the conduit portion 312 is formed centrally with respect to the first and second flanges 315a, 315b.

In one exemplary aspect, the inner diameter of bore 313 is sized to be just slightly larger (e.g., about 20% larger or less) than the outer diameter of the communications line disposed therein. In another aspect, the conduit portion can include a strength member, such as aramid (e.g., Kevlar™) yarn.

Optionally, as is shown in Fig. 1C, duct 310' can include dual recess portions 314 formed between the conduit 312 and the flanges 315a, 315b. The recessed portions provide further duct flexibility for corner installation and bending.

In a preferred aspect, the duct 310 includes a rear surface 316 that has a generally flat surface shape. This flat surface provides suitable surface area for adhering the duct 310 to a mounting surface, a wall or other surface (e.g., finished dry wall or other conventional building material). In one aspect, surface 316 is backed with an adhesive layer 318, comprising a pressure sensitive adhesive, such as those described above, e.g., a VHB adhesive (as described above) or a removable adhesive, such as a stretch release pressure sensitive adhesive (such as that described above), and having a removable liner 319. In use, the liner can be removed and the duct 310 can be applied to a mounting surface via adhesive layer 318.

Optionally, duct 310 can further include a strength member 317. Strength member 317 comprises a material, such as an aramid string (e.g., a woven or non-woven Kevlar™ material) or aramid yarn that can be bonded or un-bonded, such as those described above. The strength member 317 runs lengthwise with the main body of duct 310 and can be disposed between the bottom surface 316 and adhesive layer 318. In a preferred aspect, the strength member 317 is disposed centrally (with respect to the duct's width). In other aspects, the strength member 317 may be disposed closer to one side of the duct than the other side (e.g., directly between flange 315a and adhesive layer 318 or between flange 315b and adhesive layer 318). In an alternative aspect, the strength member 317 can be disposed within the conduit portion 312/bore 313.

A drop cable can be disposed within duct 310 and can be accessed and connected to the service line(s) at an access box 150 (see Fig. 3, described below) or a base unit 180 (see Fig. 4, described below). In one aspect, the drop cable comprises a tight bend radius, 900 μm buffered optical fiber. Such an optical fiber cable is commercially available as

DrakaElite™ BendBright Elite Single Mode Optical Fiber, from Draka Communications. Also in this aspect, an exemplary drop cable comprises a 2.9 mm jacketed drop cable commercially available as ez Patch™ cabling and ez Drop™ cabling from Draka Communications, or blown fiber cabling, or the other exemplary drop cables described
5 above. A coupling or adapter can be used to connect the telecommunications service line to the drop fiber.

Figs. 1D and 1E show other alternative ducts 410 and 510 that are utilized to carry multiple communication lines. For example, Fig. 1D shows a duct 410 having an elongated structure with a conduit portion 412 having a bore 413 extending longitudinally
10 therethrough. The conduit portion includes multiple fiber channels formed lengthwise therein to accommodate multiple optical fibers (optical fibers 405a–405f, such as 250 μm fibers, are shown in Fig. 1D, although a greater or fewer number of optical fibers may be utilized). Duct 410 also includes a flange structure having a first flange 415a and a second flange 415b, both laterally extending from the conduit portions to provide support for the
15 duct 310 as it is installed on a wall or other generally flat surface. The duct 410 includes a rear surface 416 that has a generally flat surface shape. The flanges 415a, 415b and surface 416 can be formed in the same manner as described above. As shown in Fig. 1D, an adhesive layer 418 can be disposed on surface 416.

Optionally, duct 410 can further include a strength member 417. Strength member
20 417 comprises a material, such as an aramid string or aramid yarn, such as those described above. The strength member 417 runs lengthwise with the main body of duct 410 and is disposed between the bottom surface 416 and adhesive layer 418. In a preferred aspect, the strength member 417 is disposed centrally (with respect to the duct's width).

Fig. 1E shows a duct 510 having an elongated structure with a conduit portion 512
25 having a bore 513 extending longitudinally therethrough. The conduit portion includes multiple fiber channels formed lengthwise therein to accommodate multiple optical fibers (optical fibers 505a–505f are shown in Fig. 1E, although a greater or fewer number of optical fibers may be utilized). Duct 510 also includes a flange structure having a first flange 515a and a second flange 515b, both laterally extending from the conduit portions
30 to provide support for the duct 510 as it is installed on a wall or other generally flat surface. The duct 510 includes a rear surface 516 that has a generally flat surface shape.

The flanges 515a, 515b and surface 516 can be formed in the same manner as described above. As shown in Fig. 1E, an adhesive layer 518 can be disposed on surface 516.

Optionally, duct 510 can further include a strength member 517. Strength member 517 comprises a material, such as an aramid string or aramid yarn that can be bonded or
5 un-bonded, such as those described above. The strength member 517 runs lengthwise with the main body of duct 510 and is disposed between the bottom surface 516 and adhesive layer 518. In a preferred aspect, the strength member 517 is disposed centrally (with respect to the duct's width).

In a further alternative, an exemplary duct includes at least one additional conduit,
10 where the first conduit is configured to contain at least a first communication line and the additional conduit is configured to contain at least a second communication line. For example, as shown in Fig. 1F, duct 610 that is utilized to carry multiple communication lines individually in separate conduit portions 612a-612d, each having a bore 613a-613d configured to house an individual line 605a-605d. The individual lines can each comprise
15 an optical fiber. Duct 610 is an elongated structure that also includes a flange structure having a first flange 615a and a second flange 615b, both laterally extending from the conduit portions to provide support for the duct 610 as it is installed on a wall or other mounting surface. In one preferred aspect, as is shown in Fig. 1F, the conduit portions disposed adjacent each other on the upper surface of the flange structure in the same plane.
20 The duct 610 includes a rear surface 616 that has a generally flat surface shape. One or more strength members, in this case strength members 617a-617d, can be disposed between the bottom surface 616 and adhesive layer 618.

The configuration of the exemplary multi-conduit ducts, such as duct 610, can be particularly useful for living units in countries where multiple communication lines are
25 required—the fiber channels or separate conduits can allow for straightforward installation.

In yet a further alternative, an exemplary duct includes at least one additional conduit, where the first conduit is configured to contain at least a first optical fiber communication line and the additional conduit is configured to contain at least a first electrical communication line.

30 In another aspect, an alternative duct 710 is shown in Fig. 5A. Duct 710 can include a bore 713 formed in the conduit portion 712. Duct 710 also includes a wing-shaped flange structure having a first flange 715a and a second flange 715b, both laterally

extending from the conduit portion 712, to provide support for the duct 710 as it is installed on a wall or other generally flat surface. The duct 710 includes a rear surface 716 that has a generally flat surface shape. In addition, duct 710 can optionally include dual recess portions 717 formed between the conduit portion 712 and the flanges 715a, 715b to provide further duct flexibility for corner bending. In this particular aspect, conduit portion 712 is formed centrally with respect the flange wings and with respect to the plane of the wing-shaped flanges 715a, 715b. The flanges 715a, 715b and surface 716 can be formed in the same manner as described above. As shown in Fig. 5A, an adhesive layer 718 with a removable liner 719 is disposed on surface 716. In use, the liner can be removed and the surface 716 can be applied to a mounting surface via adhesive layer 718. Adhesive layer 718 can comprise an exemplary adhesive such as those described above. Optionally, duct 710 can further include a strength member such as those described above. The strength member can run lengthwise with the main body of duct 710 and can be disposed between the bottom surface 716 and adhesive layer 718. In an alternative aspect, the strength member can be disposed within the conduit portion 712/bore 713.

In another aspect, an exemplary adhesive backed duct can further include an open top or slot that runs the longitudinal length of the duct to provide access for inserting or removing the fiber(s). For example, as shown in Fig. 5B, alternative duct 810 includes a slot 811 configured to provide for the straightforward insertion of a drop fiber, such as drop fiber 305. The slot 811 can be formed during the extrusion process as a permanent slot or, alternatively, it can be formed in the factory or in the field using a cutting tool to provide a longitudinal opening in the duct. The tool can be applied to an empty duct or a duct that is pre-populated with one or more communication lines (e.g., drop fiber(s), such as drop fiber 305). In a further alternative, slot 811 runs only a portion of the longitudinal length of the duct 810. Thus, a communication line can be easily inserted into or removed from duct 810.

In one aspect, the slot opening 811 has a size of about 50% or less of the communication line/drop fiber. In another aspect, the slot opening has a size of from about 10% to about 50% of the communication line/drop fiber outer diameter. For example, in some applications, a communication line can be inserted in slot 811 such that a portion of the line is visible after insertion. In another example, for other applications, for a smaller slot opening (e.g., the sides of the slot can be touching after insertion of the

communication line), a communication line can be inserted in slot 811 such that the communication line is not visible after insertion.

Duct 810 also includes a flange structure having a first flange 815a and a second flange 815b, both laterally extending from the conduit portion 812, to provide support for the duct 810 as it is installed on a wall or other generally flat surface. The duct 810 includes a rear surface 816 that has a generally flat surface shape. In addition, duct 810 can optionally include dual recess portions formed between the conduit portion 812 and the flanges 815a, 815b to provide further duct flexibility for corner bending. The flanges 815a, 815b and surface 816 can be formed in the same manner as described above. As shown in Fig. 5B, an adhesive layer 818 with a removable liner 819 is disposed on surface 816. In use, the liner can be removed and the surface 816 can be applied to a mounting surface via adhesive layer 818. Adhesive layer 818 can comprise an exemplary adhesive such as those described above. Optionally, duct 810 can further include a strength member such as those described above.

In a further alternative aspect, an exemplary adhesive backed duct similar to duct 110 shown in Fig. 1A can further include an open top or slot that runs the longitudinal length of the duct to provide access for inserting or removing the fiber(s). For example, as shown in Fig. 5C, duct 910 includes a slot 911 configured to provide for the straightforward insertion of a drop fiber, such as drop fiber 305. The slot 911 can be formed during the extrusion process as a permanent slot or, alternatively, it can be formed in the factory or in the field using a cutting tool to provide a longitudinal opening in the duct. The tool can be applied to an empty duct or a duct that is pre-populated with one or more communication lines (e.g., drop fiber(s), such as drop fiber 305). In a further alternative, slot 911 runs only a portion of the longitudinal length of the duct 910. Thus, a communication line can be easily inserted into or removed from duct 910. Fig. 5D shows drop fiber 305 inserted within duct 910.

In one aspect, the slot opening 911 has a size of about 50% or less of the communication line/drop fiber. In another aspect, the slot opening has a size of from about 10% to about 50% of the communication line/drop fiber outer diameter. For example, in some applications, a communication line can be inserted in slot 911 such that a portion of the line is visible after insertion. In another example, for other applications, for a smaller slot opening (e.g., the sides of the slot can be touching after insertion of the

communication line), a communication line can be inserted in slot 911 such that the communication line is not visible after insertion.

Duct 910 also includes a flange structure having a first flange 915a and a second flange 915b, both laterally extending from the conduit portion 912, to provide support for the duct 910 as it is installed on a wall or other generally flat surface. The duct 910
5 includes a rear surface 916 that has a generally flat surface shape. In addition, duct 910 can optionally include dual recess portions formed between the conduit portion 912 and the flanges 915a, 915b to provide further duct flexibility for corner bending. The flanges 915a, 915b and surface 916 can be formed in the same manner as described above. As
10 shown in Fig. 5C, an adhesive layer 918 with a removable liner 919 is disposed on surface 916. In use, the liner can be removed and the surface 916 can be applied to a mounting surface via adhesive layer 918. Adhesive layer 918 can comprise an exemplary adhesive such as those described above. Optionally, duct 910 can further include a strength
member such as those described above.

15 In a further alternative, an exemplary duct that includes at least one additional conduit, where the first conduit is configured to contain at least a first communication line and the additional conduit is configured to contain at least a second communication line can further include an open top or slot that runs the longitudinal length of the duct. For
example, as shown in Fig. 5E, duct 1010 that is utilized to carry multiple communication
20 lines individually in separate conduit portions 1012a–1012d, each having a bore 1013a–1013d configured to house an individual line 1001a-1001d. The communication lines can be optical fibers, such as drop fibers, or electrical wires. Duct 1010 also includes a flange structure having a first flange 1015a and a second flange 1015b, both laterally extending
from the conduit portions to provide support for the duct 1010 as it is installed on a wall or
25 other mounting surface. The duct 1010 includes a rear surface 1016 that has a generally flat surface shape. Optionally, duct 1010 can further include one or more slots that run the longitudinal length of the duct to provide access for inserting or removing the
communication lines. For example, as shown in Fig. 5E, alternative duct 1010 can include
slots 1011a-1011d each configured to provide for the straightforward insertion/removal of
30 drop fibers, such as drop fibers 1001a-1001d. In a further aspect, one or more strength members can be disposed between the bottom surface 1016 and adhesive layer 1018. Adhesive layer 1018 can comprise an exemplary adhesive such as those described above.

Optionally, duct 1010 can further include one or more strength members such as those described above.

The configuration of duct 1010 can be particularly useful for living units in countries where multiple communication lines are required—the fiber channels or separate
5 conduits can allow for straightforward installation.

In a further alternative aspect, Fig. 6A shows a cross section view and Fig. 6B shows an isometric view of an alternative duct 1110. Duct 1110 includes an open conduit portion, with a main fiber channel 1113 formed between opposing walls 1114a and 1114b. The main fiber channel 1113 has a width that corresponds to a width slightly less than the
10 diameter of a drop fiber 305, such as a 900 μm buffered optical fiber. The opening 1111 of the main fiber channel 1113 is configured to receive the drop fiber 305 and the opposing side walls 1114a and 1114b are configured to provide some flexibility so that the drop fiber 305 can snugly fit within main fiber channel. Duct 1110 also includes a flange structure having a first flange 1115a and a second flange 1115b to provide support for the
15 duct 1110 as it is installed on a wall or other generally flat surface, such as a wall. In this aspect, the flange extends along the longitudinal axis of the duct and extends outward (in a wing shape) in both lateral directions. In a preferred aspect, the duct 1110 includes a rear surface 1116 that has a generally flat surface shape to receive an adhesive layer 1118 having a removable liner 1119. Duct 1110 can be formed from a clear or translucent
20 polymeric material, such as a polycarbonate, making it less visible, while retaining flexibility and robustness. The adhesive layer 1118 can comprise an exemplary adhesive such as those described above. In another aspect, the adhesive layer 1118 can be formed from a clear material.

As is shown in Fig. 6B, duct 1110 can be provided in segmented form. For
25 example, duct segments 1112a and 1112b are shown in Fig. 6B. An opening 1109 can be formed between each duct segment. In addition, at the segment opening, the flange structure can include a raised surface or bump 1108 extending laterally across the fiber axis to provide for easier bending of the entire duct at certain mounting locations. In other alternative aspects, the longitudinal length of the duct segments (and the segment
30 openings) can longer or shorter, depending on the application.

Another alternative aspect is shown in Fig. 7A, where duct 1212 can include multiple conduits. For example in Fig. 7A, the duct 1210 can include multiple conduits,

in this example conduit 1212 includes a first bore 1213a, whereas second lengthwise bore 1213b and third lengthwise bore 1213c, each formed in the main duct body, provide a second conduit and a third conduit. One or more communication lines, such as those described above, can be disposed in the first bore 1213a, while strength members, such as
5 aramid yarn, metallic wire, fiberglass member, or Kevlar material, can be disposed in the second and third conduits.

Duct 1210 also includes a flange structure having a first flange 1215a and a second flange 1215b, both laterally extending from the conduit portion 1212, to provide support for the duct 1210 as it is installed on a wall or other generally flat surface. The duct 1210
10 includes a rear surface 1216 that has a generally flat surface shape. The flanges 1215a, 1215b and surface 1216 can be formed in the same manner as described above. As shown in Fig. 7A, an adhesive layer 1218 is disposed on surface 1216. Optionally, a removable liner (not shown), such as those as described above, may also be included. In use, the liner can be removed and the surface 1216 can be applied to a mounting surface via adhesive
15 layer 1218. Adhesive layer 1218 can comprise an exemplary adhesive such as those described above.

In another alternative aspect, Figs. 7B and 7C show views of alternative ducts 1310 and 1310'. In the alternative aspect shown in Fig. 7B, duct 1310 can include a bore 1313 formed in the conduit portion 1312. In this aspect, duct 1310 includes flange structure
20 having a single-sided flange 1315 or similar flattened portion to provide support for the duct 1310 as it is installed on a wall or other generally flat surface. The duct 1310 includes a rear surface 1316 that has a generally flat surface shape. An adhesive backing 1318 (optionally with a removable liner – not shown) can be disposed on surface 1316 of duct 1310.

Fig. 7C shows an alternative duct 1310'. Duct 1310' is shaped similarly to duct 1310 and additionally includes a support duct 1320. In particular, support duct 1320 is coupled to duct 1310 by attaching to the opposite side of adhesive backing 1318. In addition, the support duct 1320 includes a strength member channel 1322 disposed centrally and extending lengthwise therethrough to provide support for free span
30 applications.

In another alternative aspect, Fig. 8A shows a view of alternative duct 1410. In the alternative aspect shown in Fig. 8A, duct 1410 can include a bore 1413 formed in the

conduit portion 1412. In this aspect, duct 1410 includes a flange structure having a single-sided flange 1415 or similar flattened portion to provide support for the duct 1410 as it is installed on a wall or other generally flat surface. In this configuration, conduit portion 1412 is attached to flange 1415 via a thin web of material, or neck 1411. The neck 1411
5 has a thickness such that upon modest application of a peeling force, a segment of the conduit portion 1412 can be detached or peeled away from the flange 1415. In this example, the neck 1411 can have a thickness of from about 10% to about 30% of the thickness of the flange 1415. With this configuration, the telecommunication line (or multiple telecommunication lines) disposed in bore 1413 resides in the same bending
10 plane as the flange 1415, such as when placed in spool form prior to installation. In this example, a drop fiber 305, e.g., a 900 μm buffered fiber, is disposed in bore 1413. Optionally, a strength member, such as aramid (e.g., Kevlar) yarn, can also be disposed in bore 1413. The separated conduit portion 1412/drop fiber 305 can be terminated via a standard termination.

15 The duct 1410 can be formed from the same materials as described above with respect to the other alternative ducts.

In addition, the configuration of duct 1410 can make in-plane turns and bends of any angle more straightforward. For example, as shown in Fig. 8B, duct 1410 can be placed at a right angle, in-plane turn on a wall surface by separating conduit 1412 from
20 flange 1415 and removing a portion of flange 1415 at the bend location.

In a further alternative aspect, the conduit portion 1412 can further include a metal wire disposed therein that retains its bent shape upon bending. This alternative configuration can allow for more straightforward bending around outer and inner corners, as the duct more easily holds its bent shape. In a further alternative, conduit portion 1412
25 can further include a coaxial (e.g., micro-coaxial) wire or twisted wire pair.

Referring back to Fig. 8A, the duct 1410 also includes a rear surface 1416 that has a generally flat surface shape. An adhesive backing 1418 (optionally with a removable liner – not shown) can be disposed on surface 1416 of duct 1410. The adhesive backing may be formed from any of the adhesives described above.

30 Optionally, duct 1410 may further include a separate strength member channel 1422. In another alternative aspect, duct 1410 can include a strength member, such as an

aramid string or aramid yarn, such as those described above, disposed along the length of the duct between bottom surface 1416 and adhesive layer 1418.

Fig. 8C shows an alternative duct 1510, that includes a bore 1513 formed in the conduit portion 1512. In this aspect, duct 1510 includes a flange structure having a
5 double-sided flange 1515a, 1515b or similar flattened portion to provide support for the duct 1510 as it is installed on a wall or other generally flat surface. In this configuration, conduit portion 1512 is attached to a central portion of flange structure 1515a, 1515b via a
thin web of material, or neck 1511. The neck 1511 has a thickness such that upon modest application of a peeling force, a segment of the conduit portion 1512 can be detached from
10 the flange structure. In this example, the neck 1511 can have a thickness of from about 10% to about 30% of the outer diameter of conduit portion 1512. In this example, a drop fiber 305, e.g., a 900 μm buffered fiber, is disposed in bore 1513. Optionally, a strength member, such as aramid (e.g., Kevlar) yarn, can also be disposed in bore 1513. The separated conduit portion 1512/drop fiber 305 can be terminated via a standard
15 termination.

The duct 1510 can be formed from the same materials as described above with respect to the other alternative ducts.

In an alternative aspect, duct 1510 can include multiple conduit portions disposed on top of flange structure 1515a, 1515b, with each conduit portion attached to the flange
20 structure via a thin web of material such that each conduit portion can be detached from the flange structure upon the modest application of a peeling force.

In addition, the configuration of duct 1510 can make in-plane turns and bends of any angle more straightforward. For example, as shown in Fig. 8D, duct 1510 can be placed at a right angle, in-plane turn on a wall surface by separating conduit 1512 from
25 flange structure 1515a, 1515b and removing a portion of flange structure 1515a, 1515b at the bend location.

In a further alternative aspect, the conduit portion 1512 can further include a metal wire that retains its bent shape upon bending. This alternative configuration can allow for more straightforward bending around outer and inner corners, as the duct more easily
30 holds its bent shape. In a further alternative, conduit portion 1512 can further include a coaxial (e.g., micro-coaxial) wire or twisted wire pair.

Referring back to Fig. 8C, the duct 1510 also includes a rear surface 1516 that has a generally flat surface shape. An adhesive backing 1518 (optionally with a removable liner—not shown) can be disposed on surface 1516 of duct 1510. The adhesive backing may be formed from any of the adhesives described above.

5 Optionally, duct 1510 may further include a separate strength member channel 1522. In another alternative aspect, duct 1510 can include a strength member, such as an aramid string or aramid yarn, such as those described above, disposed along the length of the duct between bottom surface 1516 and adhesive layer 1518.

 In a further alternative aspect, Fig. 9A shows a view of alternative duct 1610. In
10 the alternative aspect shown in Fig. 9A, duct 1610 includes dual conduits 1612a, 1612b having a flange structure 1615 disposed in between. A bore 1613a is formed in the conduit portion 1612a and a bore 1613b is formed in the conduit portion 1612b. In this aspect, duct 1610 includes a flange structure having a single flange 1615 or similar flattened portion disposed between the conduit portions to provide support for the duct
15 1610 as it is installed on a wall or other generally flat surface. In this configuration, conduit portions 1612a and 1612b are attached to flange 1615 via thin webs of material, or necks 1611a and 1611b. The necks 1611a and 1611b each have a thickness such that upon modest application of a peeling force, a segment of the conduit portions 1612a and/or 1612b can be detached or peeled away from the flange 1615. In this example, necks
20 1611a and 1611b can each have a thickness of from about 10% to about 30% of the thickness of the flange 1615. With this configuration, the telecommunication line (or multiple telecommunication lines) disposed in bores 1613a, 1613b each reside in the same bending plane as the flange 1615, such as when placed in spool form prior to installation. In this example, drop fibers 305a, 305b are disposed in bores 1613a, 1613b. Optionally, a
25 strength member, such as aramid (e.g., Kevlar) yarn, can also be disposed in bores 1613a, 1613b. In a further alternative, duct 1610 can provide hybrid cabling, where conduit 1612a can carry a drop fiber, e.g., a 900 μm buffered fiber, or multiple fibers, and conduit 1612b can carry a coaxial cable or twisted wire pair.

 The duct 1610 can be formed from the same materials as described above with
30 respect to the other alternative ducts.

 In addition, the configuration of duct 1610 can make in-plane turns and bends of any angle more straightforward. For example, as shown in Fig. 9B, duct 1610 can be

placed at a right angle, in-plane turn on a wall surface by separating conduits 1612a and 1612b from flange 1615 and removing a portion of flange 1615 at the bend location.

In a further alternative aspect, one or both of the conduit portions 1612a, 1612b can further include a metal wire disposed therein that retains its bent shape upon bending.

5 This alternative configuration can allow for more straightforward bending around outer and inner corners, as the duct more easily holds its bent shape.

Referring back to Fig. 9A, the duct 1610 also includes a rear surface 1616 that has a generally flat surface shape. An adhesive backing 1618 (optionally with a removable liner—not shown) can be disposed on surface 1616 of duct 1610. The adhesive backing
10 may be formed from any of the adhesives described above.

Optionally, duct 1610 may further include a separate strength member channel 1622. In another alternative aspect, duct 1610 can include a strength member, such as an aramid string or aramid yarn, such as those described above, disposed along the length of the duct between bottom surface 1616 and adhesive layer 1618.

15 In a further alternative aspect, the duct utilized within an exemplary system can comprise a low-profile, adhesive-backed fiber tape. This alternative duct can include a cover material that can be selected to provide flame resistance, such as V0 flame resistance for agency listing. The cover material can be a paintable material, or, in a further alternative, cover material may be covered with a decorative molding or wall
20 paper. In this alternative aspect, the duct may be constructed in a similar manner to the adhesive-backed fiber tape described in U.S. Patent Application 12/731744, incorporated by reference herein in its entirety.

In a further alternative aspect, the duct may be substituted with a clear (substantially transparent) or translucent, pressure sensitive adhesive (PSA) tape, such as a
25 model 8686 polyurethane protective tape, or a paint protection film SGH6 and SGH12 (available from 3M Company, St. Paul, MN), with a thickness of about 20 mils or less, preferably about 6 mils to about 8 mils. These tapes may have a clear, glassy, matte, or satin finish. This tape can be utilized to support a drop fiber having a clear buffer coating. The tape may be dispensed flat from a roll and can conform to the drop fiber as it is
30 applied, where the drop fiber is disposed between the adhesive surface of the tape and the mounting wall or surface. In this manner, the drop fiber run from the point-of-entry unit to the wall receptacle can be barely visible.

While many of the ducts described herein are shown having a symmetrical shape, the duct designs can be modified to have an asymmetric shape (such as a flange wider on one side than the other), as would be apparent to one of skill in the art given the present description.

5 Moreover, the ducts described herein may be coextruded with at least two materials. A first material can exhibit properties that afford protection of the optical fibers within the conduit portion of each duct such as against accidental damage due to impact, compression, or even provide some protection against intentional misuse such as stapling. A second material can provide functional flexibility for cornering within a plane. The
10 flange portion of the duct may be extruded of a lower durometer material that allows it to be easily formed around a corner while maintaining a planar surface for secure bonding and wetting of the adhesive to the wall. The material forming the external wall near the conduits can provide a way for straightforward access such as making a window cut for accessing the fibers.

15 In some aspects, the ducts are typically extruded with a V0 flame resistant material, and can be of a material that is paintable, or in a further alternative, covered with another decorative material. In some applications, the ducts can often be filled with one or more 900 μm buffer coated bend insensitive fibers that comply with ITU 652-D, ITU 657 A and ITU 657-B standards, though other fibers may be used such as 500 μm coated
20 fibers or 250 μm coated fibers.

Fig. 2 shows a schematic view of an exemplary process that can be used to create the exemplary ducts described herein. For example, duct 110 (and/or ducts 310-1610) can be formed by laminating (via rollers 10a and 10b) the duct's main body 112 (including flange portions) to the adhesive layer 118. Optionally, in certain embodiments, a strength
25 member, such as strength member 117, can be disposed between the main body 112 and the adhesive layer 118 during lamination. As the strength member is captured by the adhesive while under tension during lamination, elongation of the assembly can be reduced. In this manner, the tension, orientation, contact point, and contact order of each component can be individually controlled. For example, if the lamination occurs with low
30 tension on the duct and adhesive, e.g., tension that is two pounds or less, the completed duct assembly with the strength member will have reduced stress before and after installation, resulting in better adhesion and less creep over time. In another alternative

aspect, the strength member can be disposed on the adhesive layer prior to laminating the adhesive layer to the main body of the duct.

Fig. 3 shows an example building, here MDU 10, that can accommodate an exemplary drop access system using the ducts described herein. MDU 10 is a multi-floor structure having a plurality of living units located therein. One example floor 20 has four living units having a common hallway 25. Feeder cable 30 brings communication lines to and from building 10. These feeder lines are spliced to the MDU's cabling at a splice closure 40. The building feeder lines 50 are distributed to the building from a fiber distribution hub (FDH) 60. Each floor includes a fiber distribution terminal (FDT) 65 that receives communication lines via riser cable 55. In the present example, a drop access system 100 coupling the communication lines from FDT 65a can be installed on hallway 25, where drop access boxes 150 can be disposed at each living unit and can receive one or more fiber optic communication lines from duct 110 (or, alternatively, any of ducts 210–1510). Exemplary drop access boxes are described in U.S. Publication No. 2009/0324188, incorporated by reference herein in its entirety. For example, duct 110 shown in Fig. 1A can be suitable for horizontal cabling applications.

In some aspects, the ducts described herein can be installed in a premise, building or living unit using an installation tool such as is described in U.S. Publication No. 2009/0324188, incorporated by reference herein in its entirety. During installation, the duct can be continuously fed to the tool from a storage reel. In some aspects, the tool can employ a pressure roller or similar device that presses the duct onto the mounting surface. This pressure can cause elongation of the flexible duct, which over time can relax, which may lead to less than optimal adhesion. The presence of a strength member disposed between the adhesive and the bottom surface of the duct/flange can help reduce potential elongation during installation, and thus reduce substantial duct relaxation after installation. In addition, the presence of a strength member disposed between the adhesive and the bottom surface of the duct/flange can help control fiber strain while winding up the pre-populated duct.

As is also mentioned above, the ducts can described herein can accommodate electrical wire drops and hybrid combination drops as well. In alternative aspects, the ducts can be configured to supply at least one of uninterrupted DC power and

uninterrupted AC power to an optical network terminal located in an individual living unit at the drop location.

In another exemplary aspect, Fig. 4 shows a schematic view of a system 200 for providing a final drop that is installed in a room, such as living unit 202 of an exemplary MDU 10 (see Fig. 3). Please note that while system 200 is preferably utilized in an MDU, it may also be utilized in a single family home or similar residence, as would be apparent to one of ordinary skill in the art given the present description.

System 200 comprises one or more point-of-entry units. In a preferred aspect, the point-of-entry unit comprises a low profile access base unit 180 mountable over or onto at least a portion of the duct 210 (which can be configured similar to duct 110, 310, or the many others described above). The point-of-entry is located at an access location point within the living unit to provide access to the horizontal cabling provided within the MDU. Low profile access base unit 180 is disposed on a living unit wall 203 as shown in Fig. 3. The low profile access base unit 180 can include a cover and a wall-mounting portion, where the cover can have a low profile (with a circular, oval, rectangular, or other geometric outer shape) and/or decorative outer design for aesthetics within the living unit.

The drop fiber(s) can be coupled to the service provider line via a standard coupling located in a drop access box 150 (see Fig. 3) disposed in a hallway of the MDU. Alternatively, the drop fiber(s) can be coupled to the service provider line via a standard coupling located between the hallway wall and the interior wall 203 of the living unit, as is described in U.S. Patent Application 61/164,176, incorporated by reference herein in its entirety.

The terminated drop fiber(s) can be carried from the low profile access base unit 180 to an anchor point, such as wall receptacle 290, via low profile duct 210. In a preferred aspect, the duct 210 (e.g., duct 110, 310 - 1510) is disposed along a wall, ceiling, under carpet, floor, or interior corner of the living unit in an unobtrusive manner, such that the aesthetics of the living unit are minimally impacted.

The wall receptacle 290 is configured to receive the drop fiber(s) and provide a connection with an optical network terminal (ONT) 295, such as a single family unit optical network terminal (SFU ONT), desktop ONT, or similar device (e.g., a 7342 Indoor Optical Terminal, available from Alcatel-Lucent or a Motorola ONT1120GE Desktop ONT). The wall receptacle 290 can be configured to provide one or more fiber

connections using a conventional SC/APC connector(s) and/or jumpers 297 to the ONT 295. In one aspect, the wall receptacle can be placed from about 6 inches to about 10 inches, preferably about 8 inches, from the floor of the living unit. The wall receptacle 290 can also accommodate one or more data lines or electrical connections. An exemplary
5 wall receptacle is described in Patent Publication No. WO 2008/124293, incorporated by reference in its entirety.

The example ducts 110–1610 shown herein are but a few of the ducts that can be utilized in accordance with the present invention and are not meant to be limiting. Other duct designs and shapes can be utilized as would be apparent to one of ordinary skill in the
10 art given the present description. For example, while many of the ducts described herein are shown having a symmetrical shape, the duct designs can be modified to have an asymmetric shape (such as a flange wider on one side than the other), as would be apparent to one of ordinary skill in the art given the present description.

Moreover, the ducts described herein may be coextruded with at least two
15 materials. A first material can exhibit properties that afford protection of the optical fiber(s) within the conduit portion of each duct such as against accidental damage due to impact, compression, or even provide some protection against intentional misuse such as stapling. A second material can provide functional flexibility for cornering.

In some aspects, the ducts are typically extruded with a V0 flame resistant
20 material, and can be of a material that is paintable, or in a further alternative, covered with another decorative material. In some applications, the ducts can often be filled with 900 μm buffer coated bend insensitive fibers that comply with ITU 652-D, ITU 657-A and ITU 657-B standards, though other fibers may be used such as 250 μm coated fibers, ribbon fibers of 2-fiber, 4-fiber or more, or even jacket fibers or bundled fibers.

In addition, the exemplary ducts described herein can be further utilized in non-
25 telecommunication applications. For example, the exemplary ducts described herein can be utilized for general wire routing within or outside a living unit, such as to route speaker/AV wires, power wires, and other signal wires.

The present invention should not be considered limited to the particular examples
30 described above, but rather should be understood to cover all aspects of the invention as fairly set out in the attached claims. Various modifications, equivalent processes, as well as numerous structures to which the present invention may be applicable will be readily

apparent to those of skill in the art to which the present invention is directed upon review of the present specification. The claims are intended to cover such modifications and devices.

What is Claimed is:

1. A duct for distributing one or more communication lines, comprising:
a flexible, elongated body having a conduit portion with a lengthwise bore formed therein, the conduit portion containing one or more communication lines;
5 a flange structure extending lengthwise adjacent the elongated body to mount the duct to a mounting surface;
a pressure sensitive adhesive layer disposed on a generally flat bottom surface of the flange structure; and
a strength member extending lengthwise with the flange structure and disposed
10 between the bottom surface and the adhesive layer.
2. A duct for distributing one or more communication lines, comprising:
a flexible, elongated body having a conduit portion with a lengthwise bore formed therein, the conduit portion containing one or more communication lines;
a flange structure extending lengthwise adjacent the elongated body to mount the
15 duct to a mounting surface;
a pressure sensitive adhesive layer disposed on a generally flat bottom surface of the flange structure; and
a strength member extending lengthwise with the flange structure and disposed within the conduit portion.
- 20 3. The duct of any of claims 1 and 2, wherein the strength member comprises an aramid string.
4. The duct of any of claims 1 and 2, wherein the strength member comprises an aramid yarn.
5. The duct of any of claims 1 and 2, wherein the strength member comprises a
25 bonded material.
6. The duct of any of the preceding claims, wherein the strength member is disposed centrally with respect to a width of the duct.

7. The duct of any of the preceding claims, wherein the conduit portion is attached to the flange structure via a thin web of material having a thickness such that upon modest application of a peeling force, a segment of the conduit portion is detachable from the flange structure.
- 5 8. The duct of any of the preceding claims, wherein the conduit portion includes a longitudinal slot formed therein to provide for insertion and removal of the at least one communication line.
9. The duct of any of the preceding claims, wherein the duct includes at least one additional conduit portion, wherein the first conduit portion is configured to contain at
10 least a first communication line and the additional conduit portion is configured to contain at least a second communication line.
10. A duct for distributing one or more communication lines, comprising:
a flexible, elongated body having a plurality of conduit portions, each conduit portion having a lengthwise bore formed therein and configured to house an individual
15 communication line;
a flange structure extending lengthwise adjacent the elongated body to mount the duct to a mounting surface; and
a pressure sensitive adhesive layer disposed on a generally flat bottom surface of the flange structure, wherein the conduit portions are disposed adjacent each other in the
20 same plane on an upper surface of the flange structure.
11. A duct for distributing one or more communication lines, comprising:
a flexible, elongated body having a conduit portion with a lengthwise bore formed therein, the conduit portion containing one or more communication lines;
a flange structure extending lengthwise adjacent the elongated body to mount the
25 duct to a mounting surface; and
a pressure sensitive adhesive layer disposed on a generally flat bottom surface of the flange structure, wherein the conduit portion includes a longitudinal slot formed therein to provide for insertion and removal of the at least one communication line.

12. The duct of claim 11, wherein the duct includes multiple conduits each having a bore formed along a longitudinal axis of the duct, wherein a first conduit is configured to hold a first drop fiber and a second conduit is configured to hold a second drop fiber.
13. The duct of claim 11 or 12, wherein the slot has a size of about 50% or less of a diameter of the at least one communication line.
14. The duct of claim 11 or 12, wherein the slot has a size of from about 10% to about 50% of the communication line outer diameter.
15. The duct of any of the preceding claims, wherein the flange structure comprises a first flange extending laterally from the conduit portion in a first direction and a second flange extending laterally from the conduit portion in a second direction.
16. The duct of claim 15, further comprising a first recess portion disposed between the conduit portion and the first flange, and a second recess portion disposed between the conduit portion and the second flange.
17. A duct for distributing one or more communication lines, comprising:
a flexible, elongated body having a conduit portion with a lengthwise bore formed therein, the conduit portion containing one or more communication lines;
a flange structure extending lengthwise adjacent the elongated body to mount the duct to a mounting surface; and
a pressure sensitive adhesive layer disposed on a generally flat bottom surface of the flange structure, wherein the conduit portion is attached to the flange structure via a thin web of material having a thickness such that upon modest application of a peeling force, a segment of the conduit portion is detachable from the flange structure.
18. The duct of claim 17, wherein the conduit portion is formed in the same bending plane as the flange structure.
19. The duct of claim 17, wherein the thin web of material has a thickness of from about 10% to about 30% of the thickness of the flange structure.

20. The duct of claim 17, wherein the conduit portion is attached to a central portion of the flange structure.

21. The duct of claim 17, wherein the conduit portion comprises dual conduit portions having the flange structure disposed in between, each of the conduit portions attached to the flange structure via a thin web of material, wherein the conduit portions are formed in the same bending plane as the flange structure.

22. The duct of claim 17, wherein the conduit portion comprises multiple conduit portions, each attached to a top surface of the flange structure via a thin web of material.

23. The duct of any of the preceding claims, wherein the adhesive layer further includes a liner that is removable prior to mounting the duct on the mounting surface.

24. The duct of any of the preceding claims, wherein the elongated body has a form factor (length versus width) of greater than 100 to 1.

25. The duct of any of the preceding claims, wherein the one or more communication lines includes an electrical wire.

26. The duct of any of the preceding claims, wherein the one or more communication lines includes a plastic optical fiber.

27. The duct of any of the preceding claims, wherein the one or more communication lines includes a single mode optical fiber.

28. The duct of any of the preceding claims, wherein the one or more communication lines includes a multi-mode optical fiber.

29. The duct of any of the preceding claims, wherein the one or more communication lines comprises a micro-module that includes a plurality of optical fibers.

30. The duct of any of the preceding claims, wherein the adhesive comprises a double sided tape.

31. The duct of any of the preceding claims, wherein the adhesive comprises a transfer adhesive.
32. The duct of any of the preceding claims, wherein the adhesive comprises a stretch release adhesive.
- 5 33. The duct of any of the preceding claims, wherein the duct has a lateral dimension from about 0.2 inches to about 1 inch, and a height of less than about 0.1 inch to about 0.5 inches.
34. The duct of any of the preceding claims, wherein an inner diameter of the bore is about 20% or less larger than an outer diameter of the drop fiber disposed therein.
- 10 35. A tape for distributing one or more communication lines within a living unit, comprising:
an optically clear or translucent pressure sensitive adhesive tape, having a communication line with a clear buffer coating, mountable to a wall within the living unit, wherein the communication line is disposed between an adhesive portion of the optically
15 clear or translucent adhesive tape and the wall.
36. A duct for distributing one or more communication lines, comprising:
a flexible, elongated body having a conduit portion with a lengthwise bore formed therein, the conduit portion containing one or more communication lines;
a flange structure extending lengthwise adjacent the elongated body to mount the
20 duct to a mounting surface; and
a pressure sensitive adhesive layer disposed on a generally flat bottom surface of the flange structure; wherein the duct is formed from an extruded polymeric material having chopped strength members mixed therein.
37. A drop access system for installation in a building, comprising the duct or tape of
25 any of the preceding claims.
38. A system for providing a final drop that is installed in a living unit, comprising the duct or tape of any of the preceding claims.

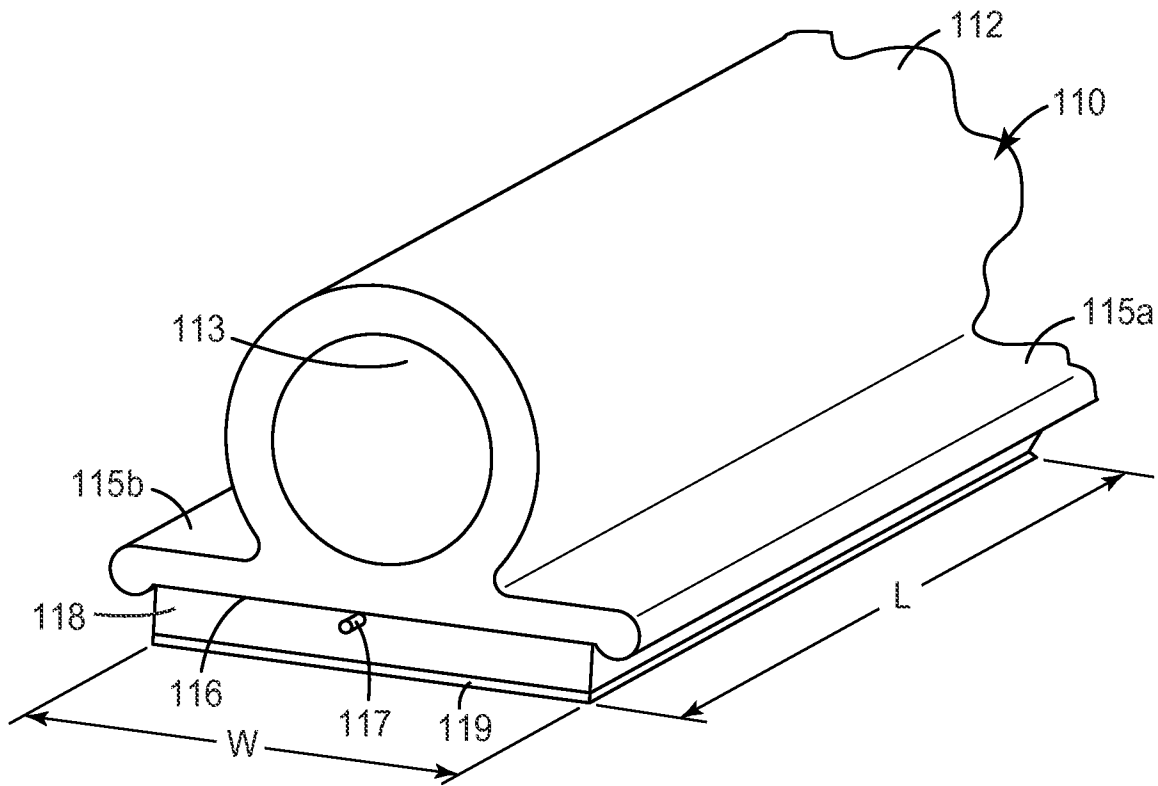

FIG. 1A

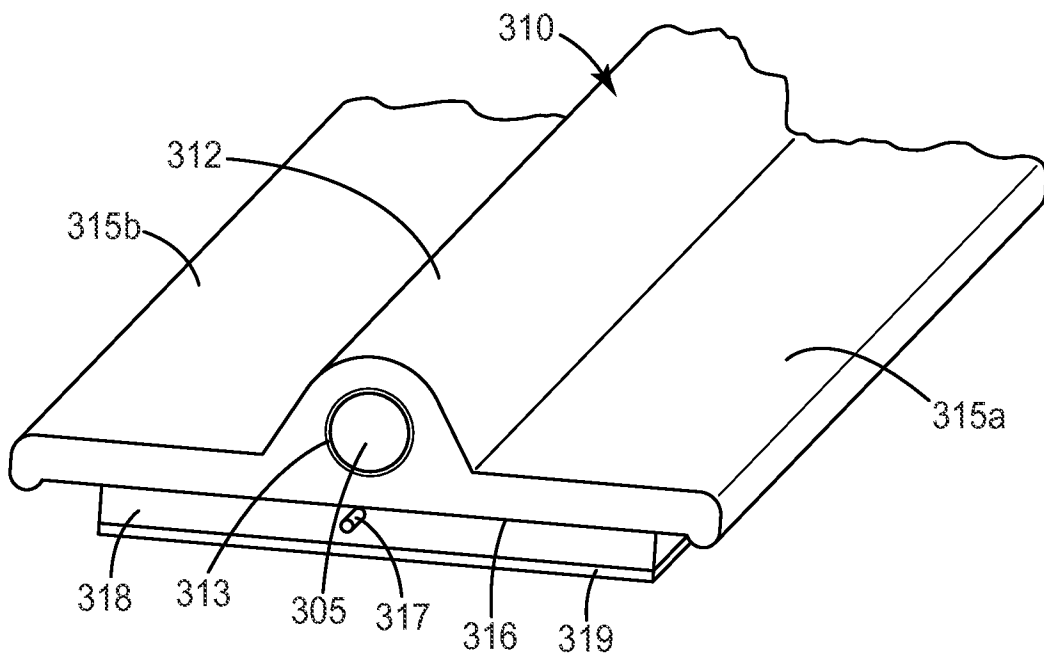

FIG. 1B

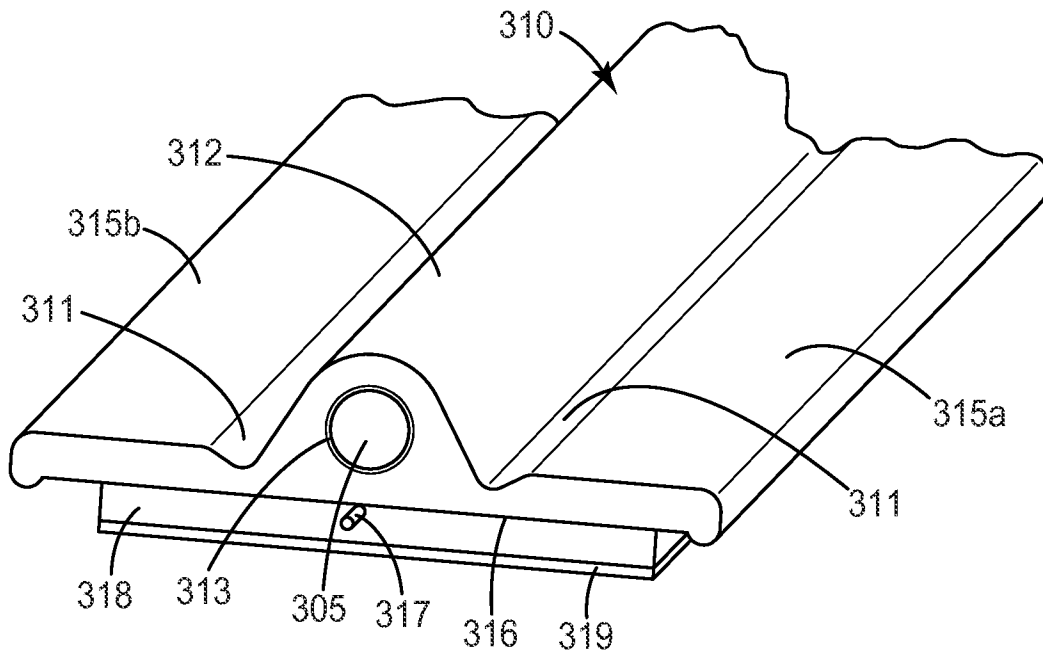

FIG. 1C

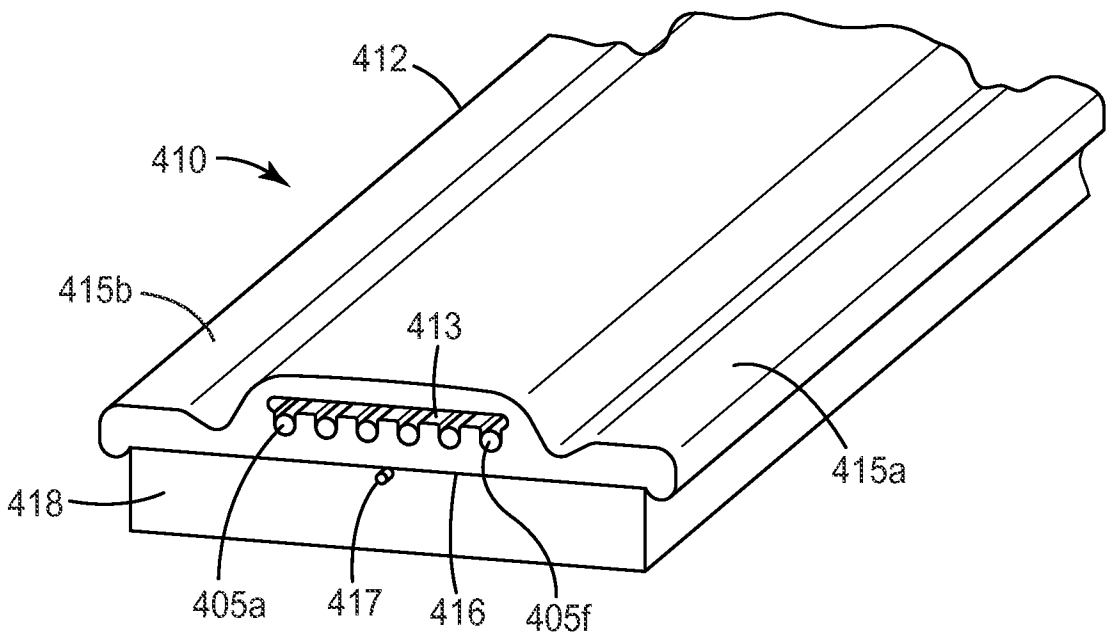

FIG. 1D

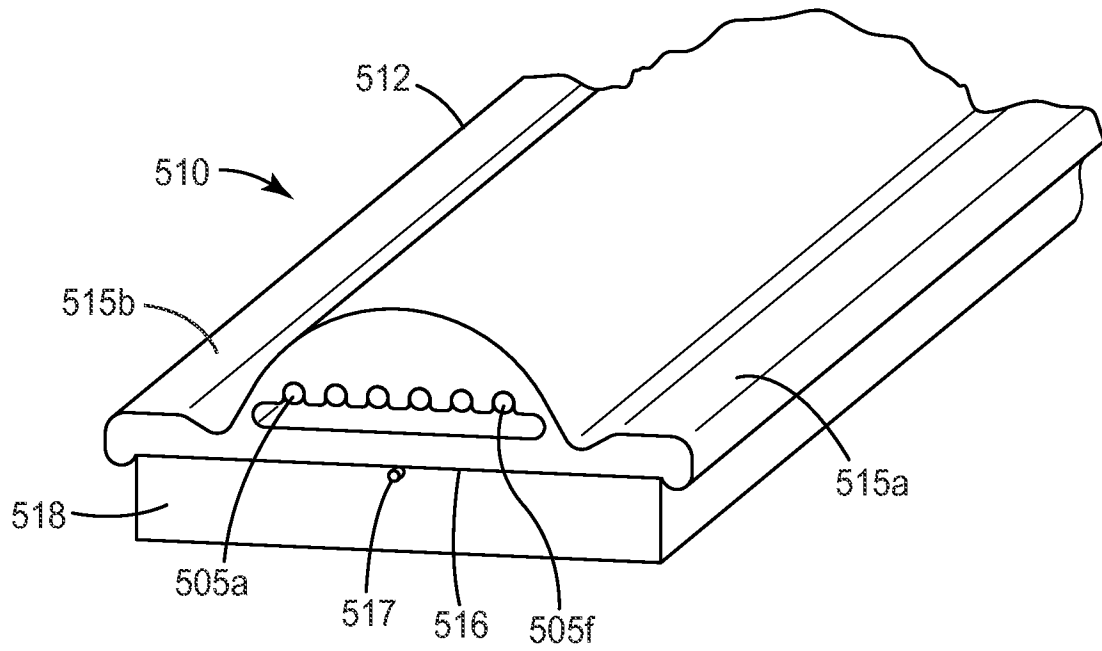

FIG. 1E

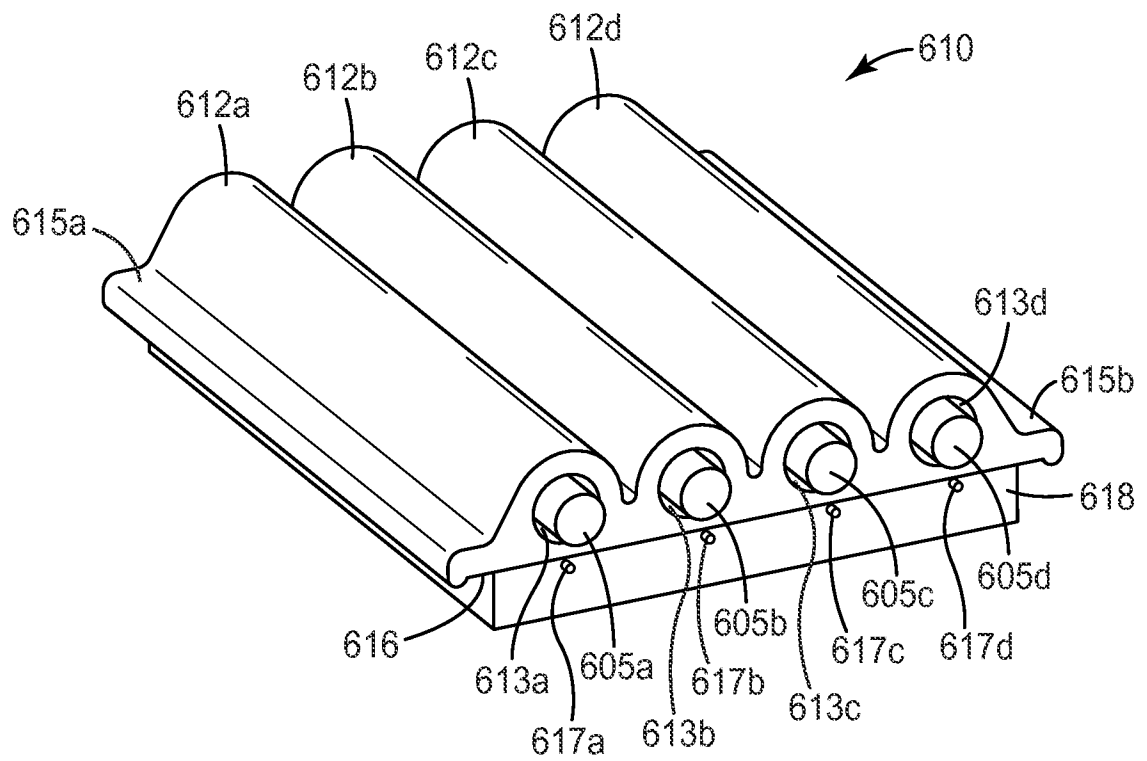

FIG. 1F

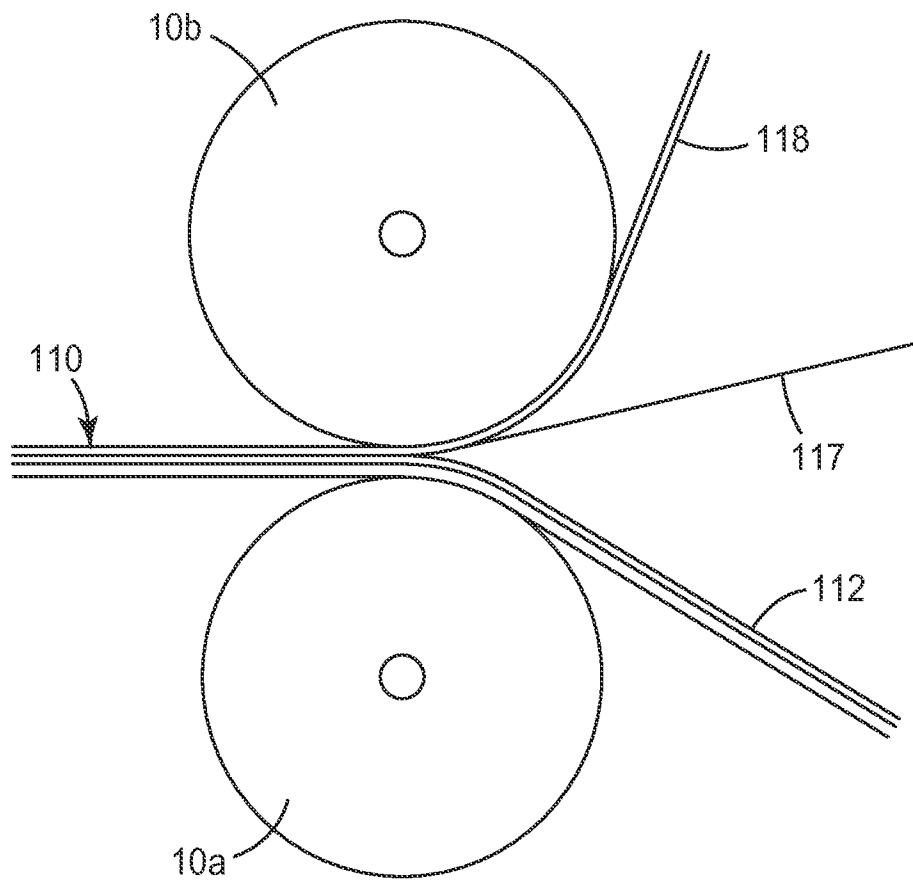

FIG. 2

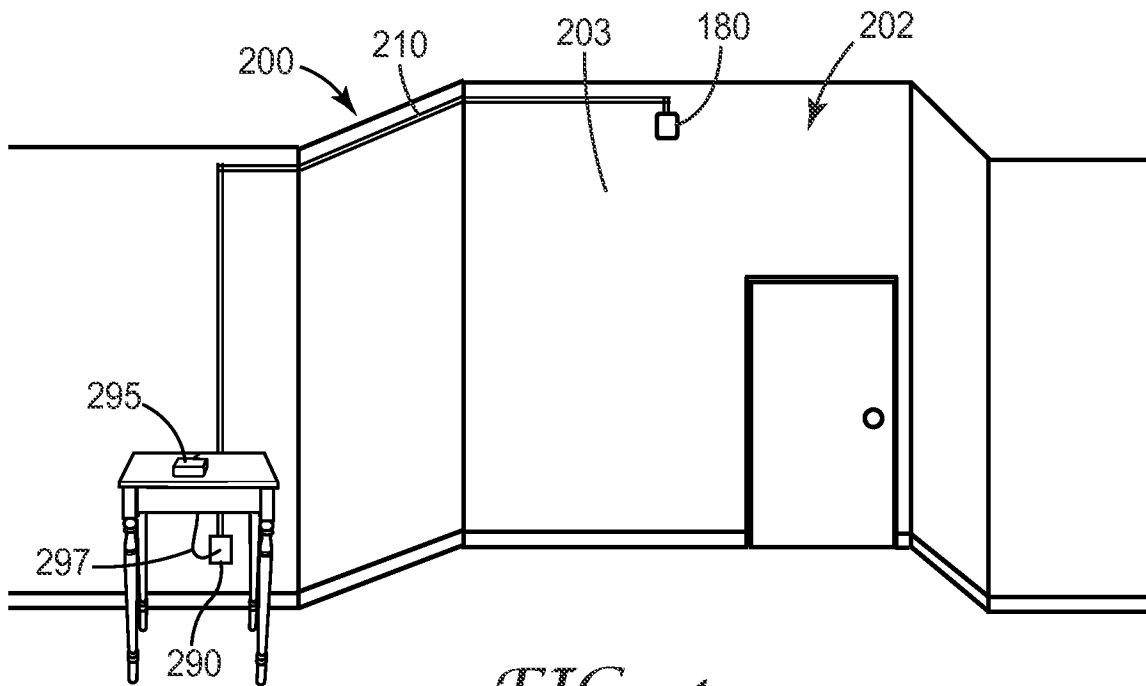

FIG. 4

7/14

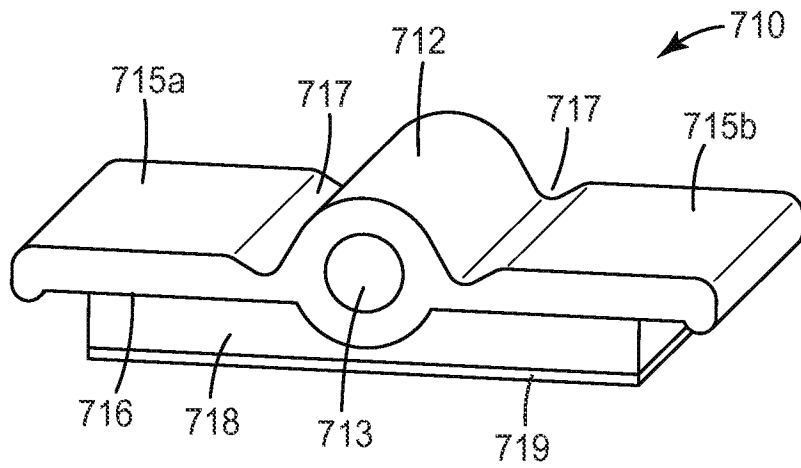

FIG. 5A

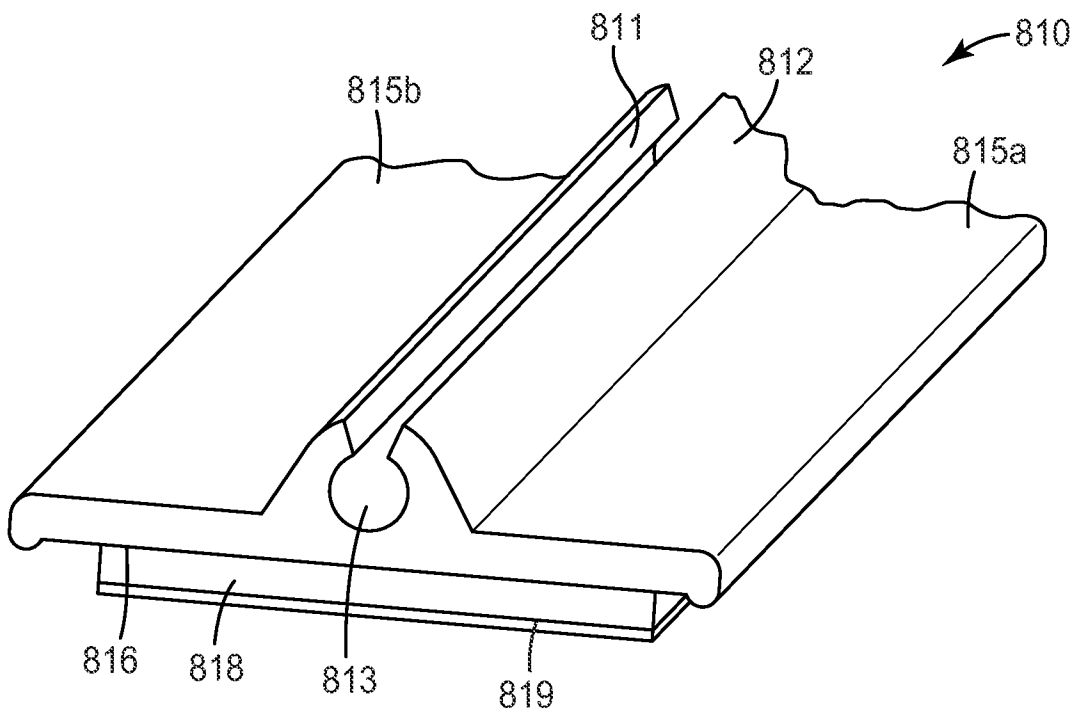

FIG. 5B

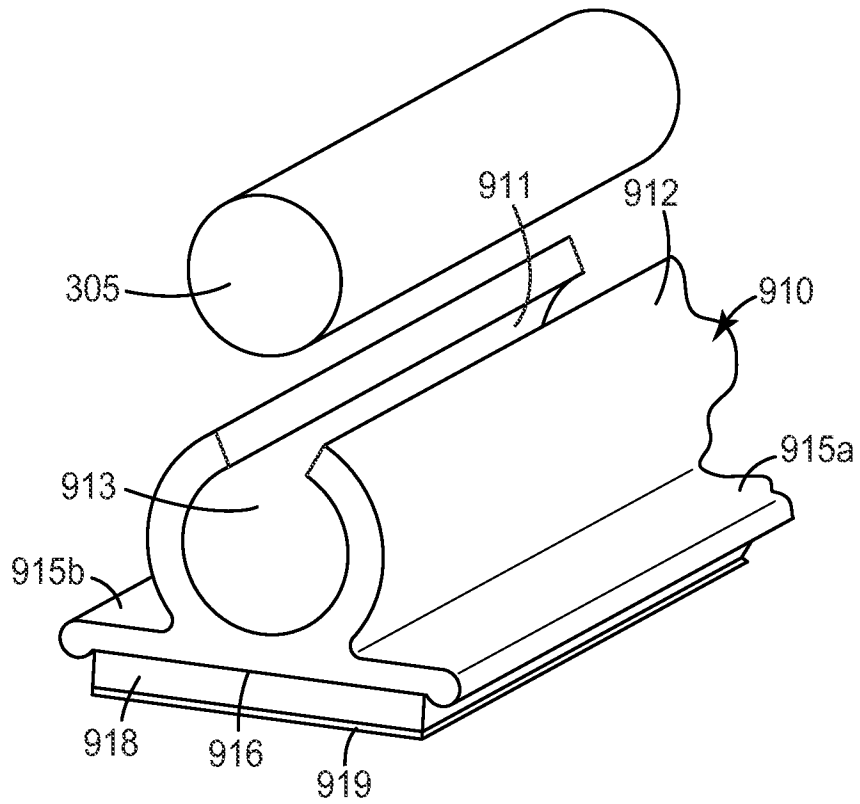

FIG. 5C

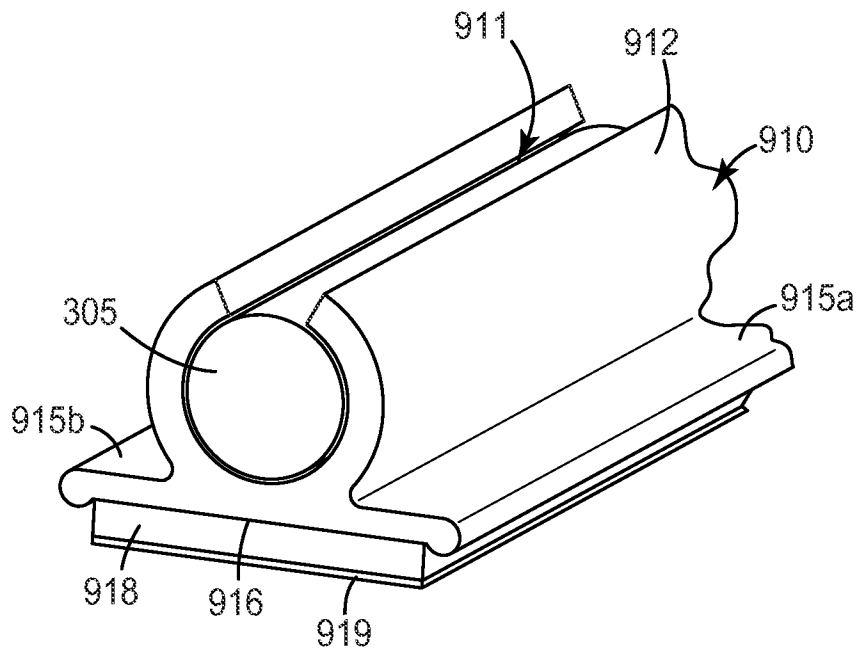

FIG. 5D

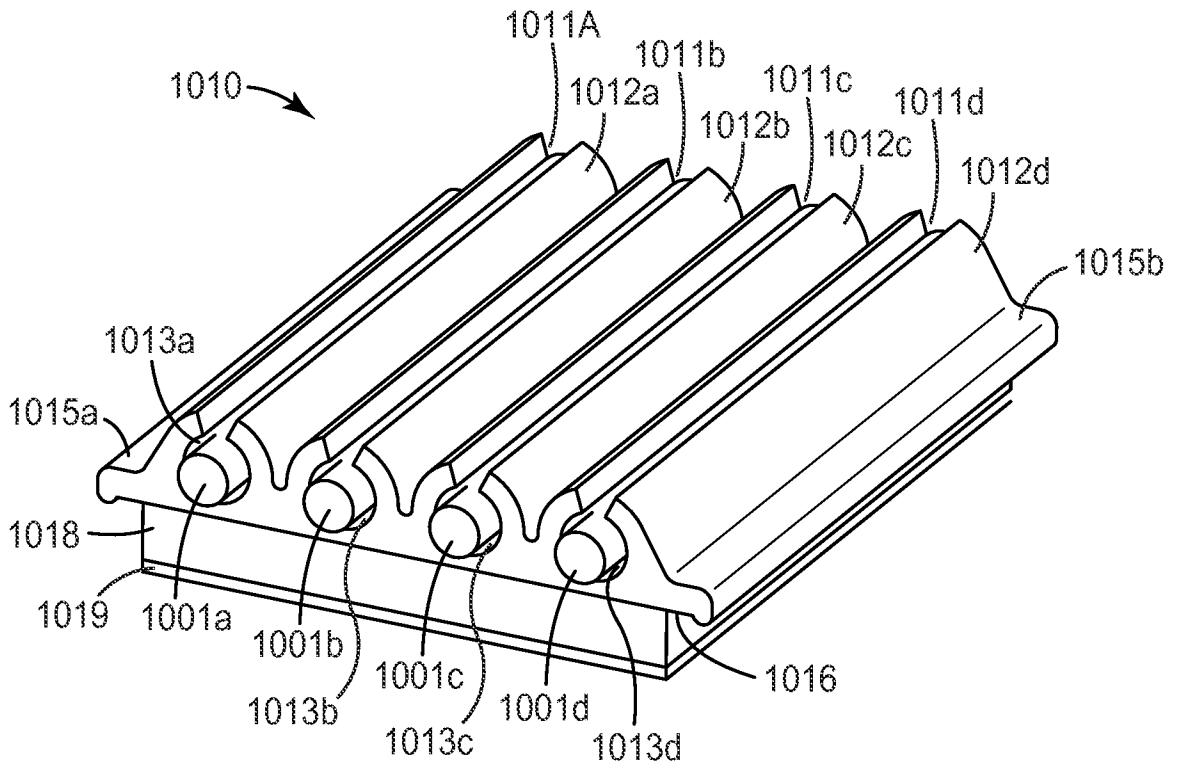

FIG. 5E

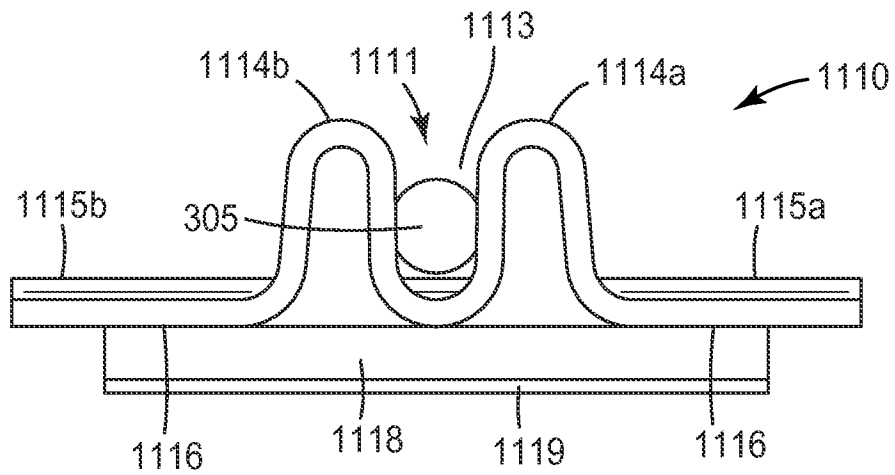

FIG. 6A

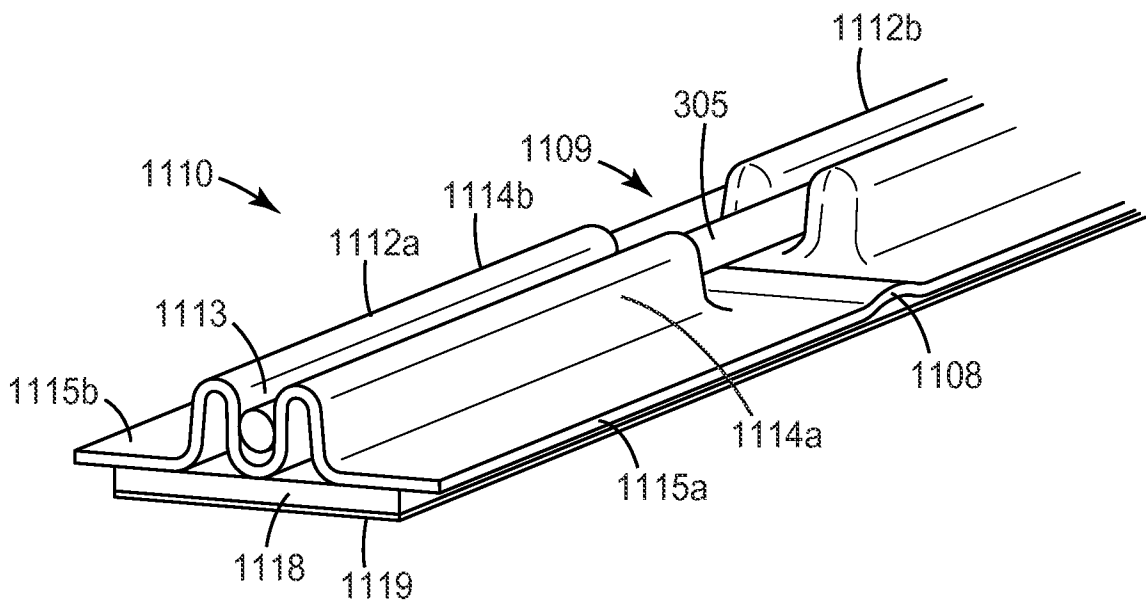

FIG. 6B

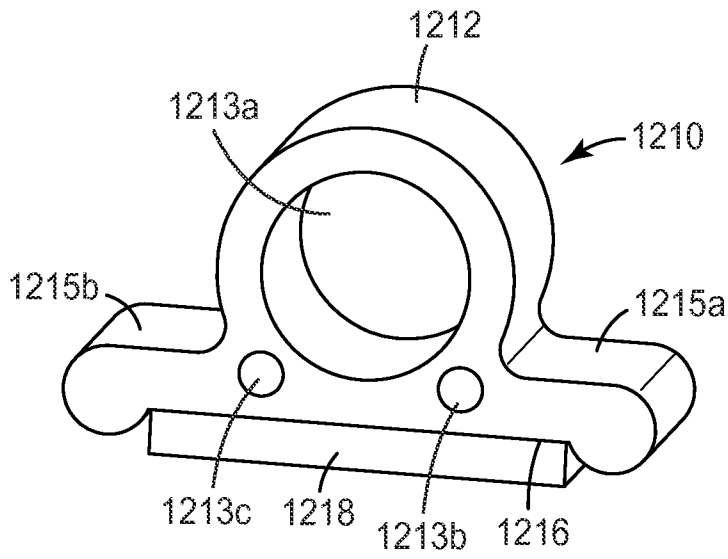

FIG. 7A

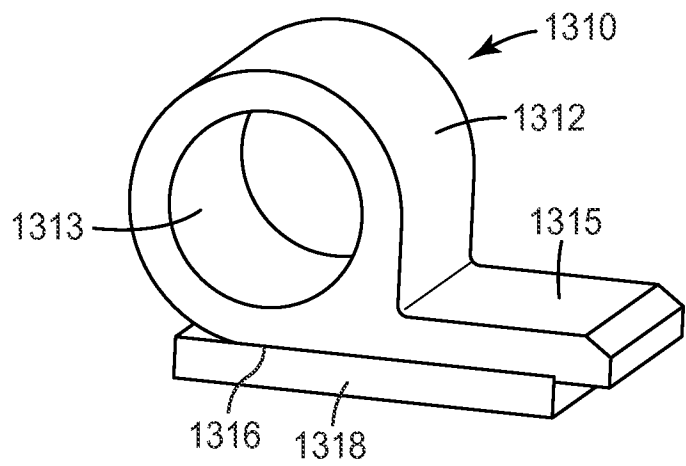

FIG. 7B

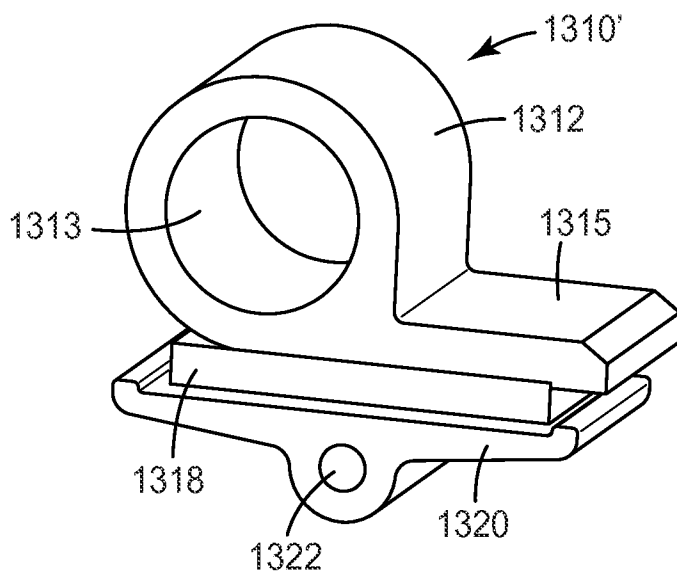

FIG. 7C

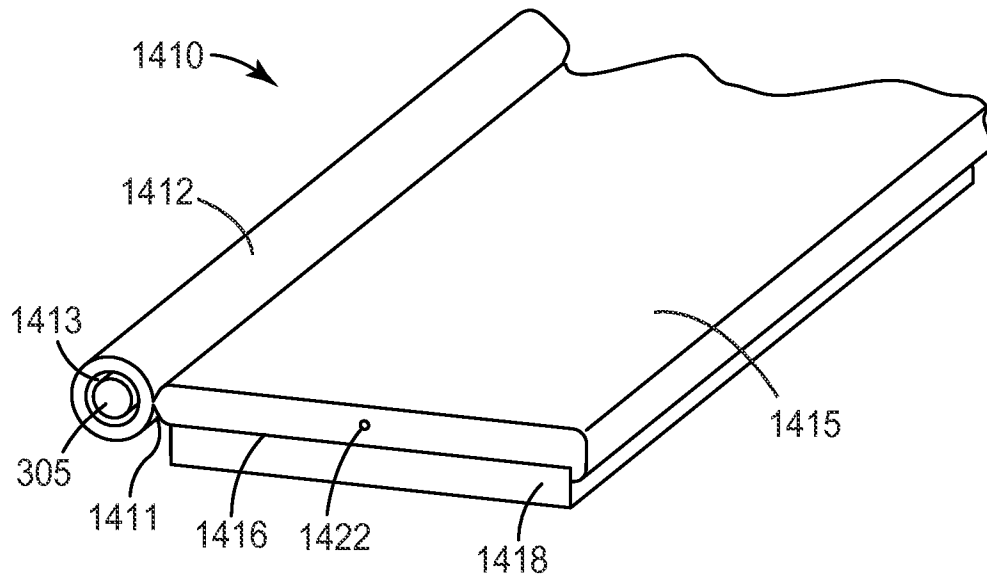

FIG. 8A

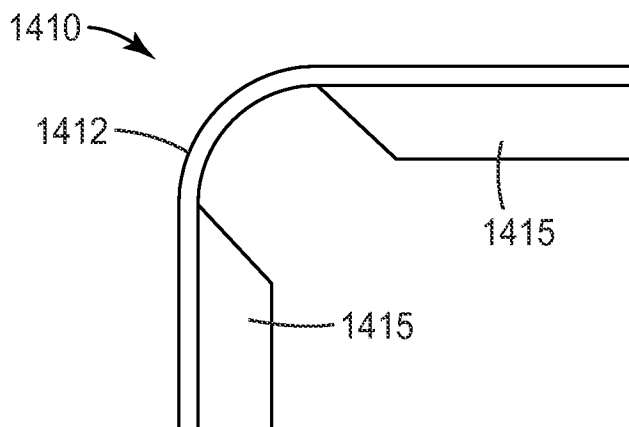

FIG. 8B

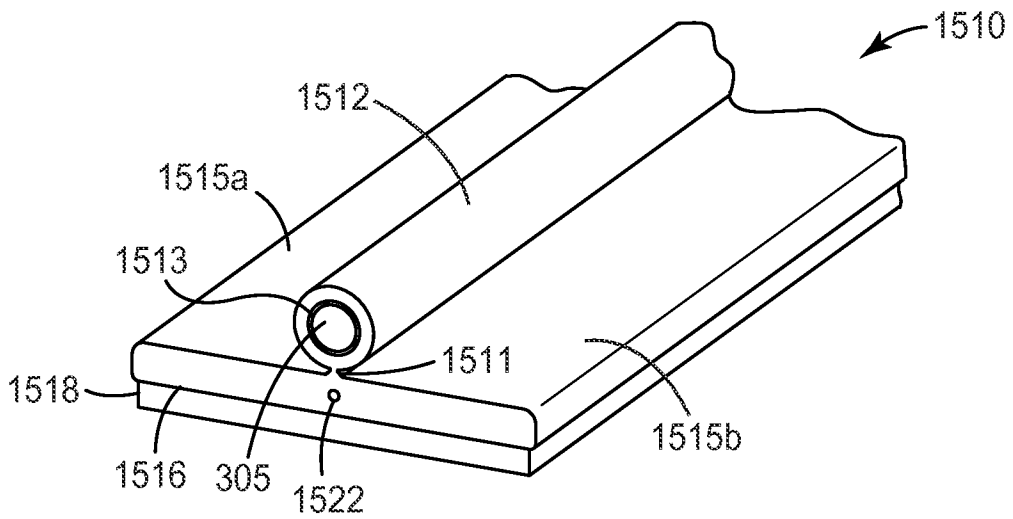

FIG. 8C

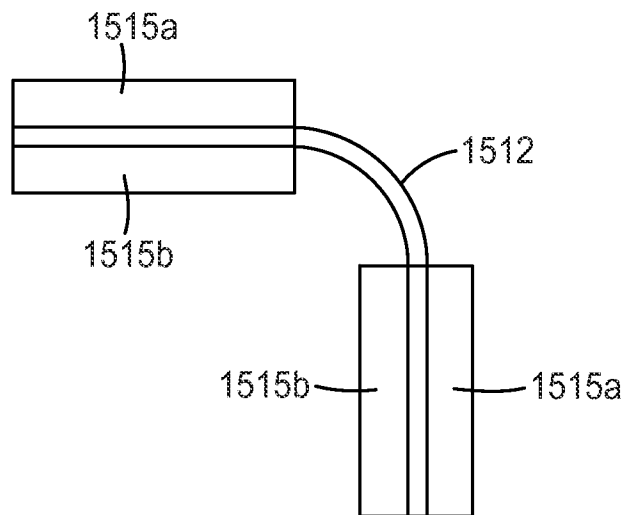

FIG. 8D

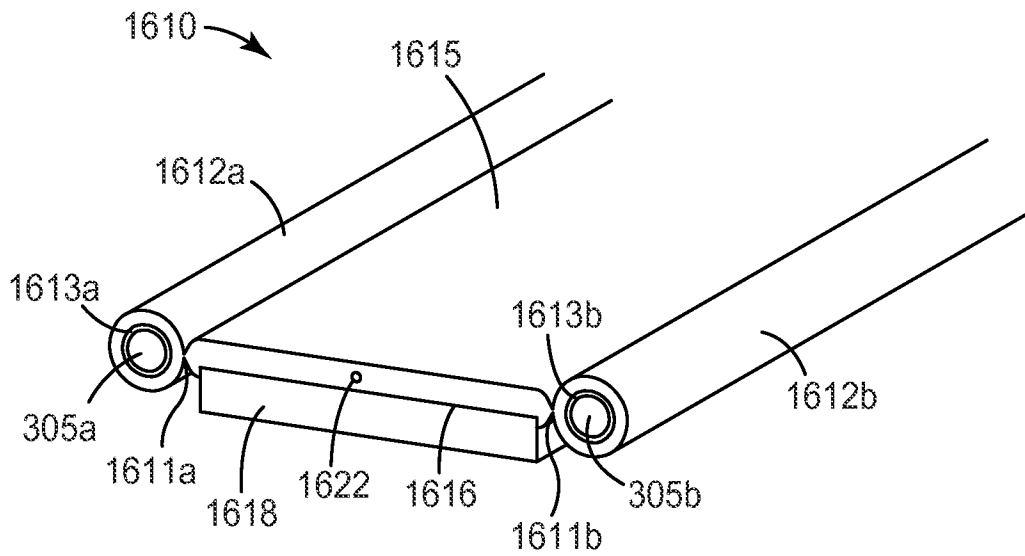

FIG. 9A

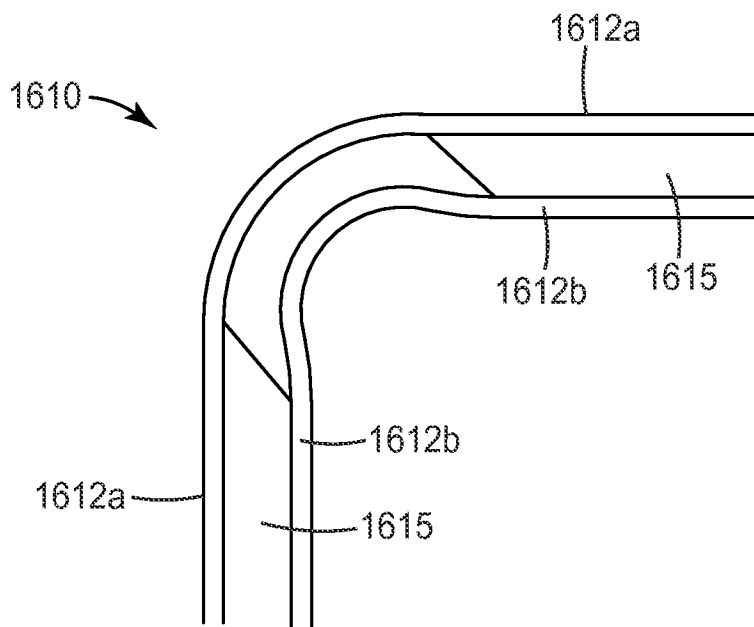

FIG. 9B