

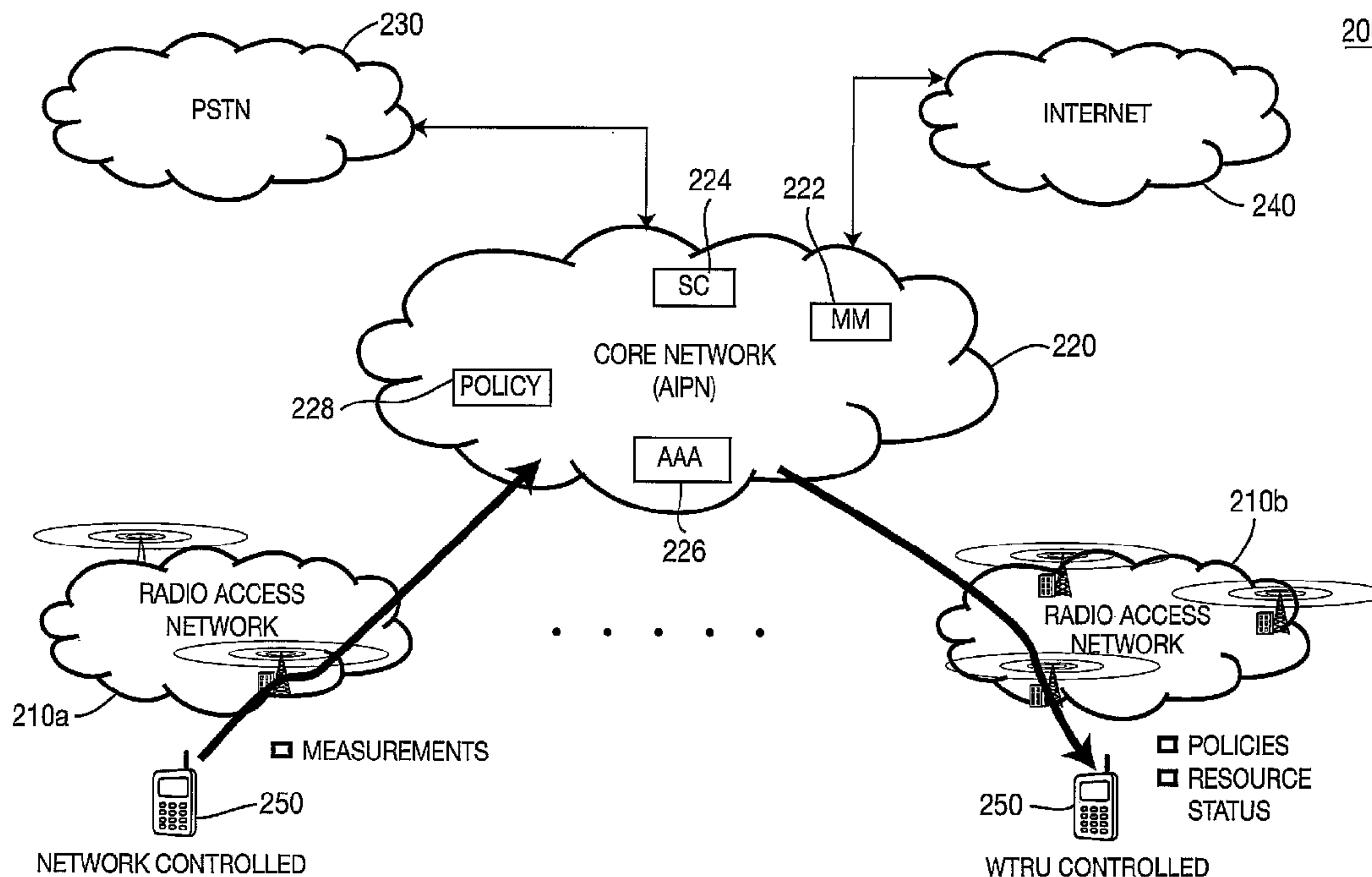

(86) Date de dépôt PCT/PCT Filing Date: 2006/07/17
 (87) Date publication PCT/PCT Publication Date: 2007/02/08
 (45) Date de délivrance/Issue Date: 2014/08/26
 (85) Entrée phase nationale/National Entry: 2008/01/16
 (86) N° demande PCT/PCT Application No.: US 2006/027628
 (87) N° publication PCT/PCT Publication No.: 2007/015795
 (30) Priorités/Priorities: 2005/07/20 (US60/700,799);
 2006/05/31 (US11/444,846)

(51) Cl.Int./Int.Cl. *H04B 7/208* (2006.01)
 (72) Inventeur/Inventor:
 SHAHEEN, KAMEL M., US
 (73) Propriétaire/Owner:
 INTERDIGITAL TECHNOLOGY CORPORATION, US
 (74) Agent: RIDOUT & MAYBEE LLP

(54) Titre : PROCÉDE ET SYSTÈME DE SUPPORT D'UN UTRAN ÉVOLUÉ
 (54) Title: METHOD AND SYSTEM FOR SUPPORTING AN EVOLVED UTRAN



(57) **Abrégé/Abstract:**

A method for use in a wireless transmit/receive unit (WTRU). The method comprises generating a message indicating evolved universal mobile telecommunication systems (UMTS) terrestrial radio access network (E-UTRAN) capability information. The capability information includes an indication of support for an orthogonal frequency division multiplex (OFDM) mode and support for UMTS terrestrial radio access network (UTRAN) to E-UTRAN handover. The message is transmitted to a UTRAN base station on a UTRAN channel. A E-UTRAN service is received based on the message.

ABSTRACT

A method for use in a wireless transmit/receive unit (WTRU). The method comprises generating a message indicating evolved universal mobile telecommunication systems (UMTS) terrestrial radio access network (E-UTRAN) capability information. The capability information includes an indication of support for an orthogonal frequency division multiplex (OFDM) mode and support for UMTS terrestrial radio access network (UTRAN) to E-UTRAN handover. The message is transmitted to a UTRAN base station on a UTRAN channel. A E-UTRAN service is received based on the message.

[0001] METHOD AND SYSTEM FOR SUPPORTING AN EVOLVED UTRAN

[0002] FIELD OF INVENTION

[0003] The present invention is related to wireless communication systems. More particularly, the present invention is related to a method and system for supporting an evolved universal mobile telecommunication systems (UMTS) terrestrial radio access network (E-UTRAN).

[0004] BACKGROUND

[0005] Different types of wireless access systems have been developed to provide different types of services and capabilities. Some examples of wireless access systems include wireless local area networks (WLANs), (such as IEEE 802-based networks), and cellular networks, (such as UMTS terrestrial radio access network (UTRAN), a global system for mobile communication (GSM)/enhanced data rate for GSM evolution (EDGE) radio access network (GERAN), or the like). Each of these networks have been developed and tailored to provide specific applications.

[0006] Proposals for an E-UTRAN (Long Term Evolution for UTRAN and evolved Node-B (E-Node-B)) have been made to improve wireless system capacity and enhance performance. The E-UTRAN will provide significant advantages over existing wireless communication systems and additional services may be available through the higher bit rate and lower latency provided by the E-UTRAN. Figure 1 shows a conventional integrated wireless communication system 100 including an E-UTRAN 114. The system 100 includes an access system stratum 110, a network stratum 120 and a multimedia stratum 130. The access system stratum 110 includes a plurality of radio access networks (RANs) 111-115, a core network (CN) 116 and an evolved CN 117. The RANs 111-115 include a generic access network (GAN) 111, a GERAN 112, a UTRAN 113, an E-UTRAN 114 and an interworking wireless local area network (I-WLAN) 115. The RANs 111-115 are connected to the CN 116 or the evolved CN 117 to provide services, (such as multimedia services from an Internet protocol (IP) multimedia

subsystem (IMS) 131), to one or more WTRUs while interacting with an authentication, authorization and accounting (AAA) server 121, a mobile IP (MIP) server 122, or other network entities in the network stratum 120 via a gateway general packet radio services (GPRS) support node (GGSN) 118 or a packet data gateway (PDG) 119.

[0007] Currently, multimode wireless transmit/receive units (WTRUs) configured to support multiple wireless communication systems are available. The capabilities of each of the WTRUs may vary. For example, some WTRUs may support only UMTS, while other WTRUs may support multiple mode of operations such as I-WLAN, GERAN, and/or E-UTRAN. The WTRUs that are capable of supporting E-UTRAN will also be available in the future.

[0008] Therefore, it would be desirable to provide a method and system for supporting an E-UTRAN such that the WTRUs may receive and utilize such additional E-UTRAN capabilities and services.

[0009]

SUMMARY

[0010] The present invention is related to a method and system for supporting an E-UTRAN. The present invention extends conventional methods and procedures for supporting multimode operations within UMTS-based wireless communication system, (i.e., UTRAN), in order to support the addition of the new technology, (i.e., E-UTRAN), to the system. The conventional procedures are specified in third generation partnership project (3GPP) standards (e.g., TS25.331). The system, herein, includes a WTRU, a UTRAN and an E-UTRAN. A conventional UTRAN sends to the WTRU a list of available radio access technologies (RATs) in a coverage area of the UTRAN. The list includes information related to the existing RAT attributes such as technology type, bit rate, bandwidth, or the like. The present invention introduces the information related to E-UTRAN to this list. The WTRU receives this list during initial access or during handoff procedures. Upon receiving the list, an E-UTRAN capable WTRU may configure/reconfigure the WTRU to receive E-UTRAN services based on the list through handoff procedures or system reselection

procedures. The E-UTRAN capable WTRU may send its multi-mode/multi-RAT capability information including the E-UTRAN capability to the UTRAN during the initial access, (i.e., attach procedures), or when requested by a system. During a normal handoff procedure, the UTRAN sends a measurement capability message to the WTRU. The measurement capability message includes parameters necessary for performing measurements on an E-UTRAN channel. The WTRU performs measurements based on the measurement capability message and reports measurement results to the UTRAN. The UTRAN may initiate a handoff to the E-UTRAN based on the measurement results. In idle operation, the WTRU may decide to re-select to the E-UTRAN based on the capability information received earlier from the UTRAN. The WTRU uses this information to configure the transmitter and receiver bandwidth, bit rate, frequency band, or the like.

[0011] BRIEF DESCRIPTION OF THE DRAWINGS

[0012] A more detailed understanding of the invention may be had from the following description of a preferred embodiment, given by way of example, and to be understood in conjunction with the accompanying drawings, wherein:

[0013] Figure 1 is a diagram of a conventional wireless communication system;

[0014] Figure 2 shows a wireless communication system configured in accordance with the present invention; and

[0015] Figure 3 is a flow diagram of a process for supporting E-UTRAN in accordance with the present invention.

[0016] DETAILED DESCRIPTION OF THE PREFERRED EMBODIMENTS

[0017] When referred to hereafter, the terminology "WTRU" includes but is not limited to a user equipment, a mobile station, a fixed or mobile subscriber unit, a pager, or any other type of device capable of operating in a wireless environment.

[0018] The features of the present invention may be incorporated into an integrated circuit (IC) or be configured in a circuit comprising a multitude of interconnecting components.

[0019] Figure 2 shows a wireless communication system 200 configured in accordance with the present invention. The system 200 includes a plurality of RANs 210a, 210b, deployed under different RATs, and a core network 220 which may be an all Internet protocol (IP) network (AIPN). The core network 220 is connected to other networks, such as a public switching telephone network (PSTN) 230, the Internet 240, or the like. Each of the RANs 210a, 210b may be a GAN, a GERAN, a UTRAN, an E-UTRAN, an IEEE-based I-WLAN, or any type of wireless access network.

[0020] In order to optimize mobility among diverse RANs 210a, 210b, the core network 220 provides open interfaces for mobility management (MM) 222 that allow the operator of the core network 220 to direct WTRUs 250 towards the most suitable RANs 210a, 210b. The core network 220 also provides open interfaces that allow the WTRUs 250 to access other AIPN services, such as session control (SC) 224, authentication, authorization and accounting (AAA) 226 and a policy control 228.

[0021] A WTRU 250 is a multi-mode WTRU equipped with at least two radio units configured to support communication with at least two different RATs. For example, the WTRU 250 may include one radio unit for communicating with an E-UTRAN and the other radio unit for communication with an I-WLAN. The WTRU 250 establishes a connection with one of the RANs and may perform a handoff to a target RAN if handoff criteria is met by the target RAN.

[0022] A handoff may be initiated manually or automatically in the system 200. In the manual handoff process initiated by a user of the WTRU 250, the user knows the existence of alternative RATs, (such as E-UTRAN), in its current geographic location and switches between them, (e.g., between the UTRAN and the E-UTRAN). The automatic handoff process may be initiated by the WTRU 250, or by the RAN 210a, 210b or the core network 220.

[0023] In the WTRU-initiated handoff, the WTRU 250 detects the existence of alternative RATs, (such as an E-UTRAN), and initiates a handoff process, (e.g., to the E-UTRAN), based on the preference of the user of the WTRU 250. The WTRU 250 receives necessary information, (such as handoff policies, resource status, or the like), from the network, (e.g., a RAN 210b or the core network 220). The WTRU 250 tracks the locations of coverage areas of the RANs 210a, 210b and initiates the handoff process based on predetermined handoff criteria.

[0024] In a system initiated handoff, the core network 220, (or the RAN 210a, 210b), recognizes that the WTRU 250 is capable of supporting multiple RATs, (including E-UTRAN), and requests necessary information, (such as power measurements), from the WTRU 250. The core network 220, (or the RAN 210a, 210b), tracks the location of the WTRU 250 and initiates the handoff procedures based on a set of criteria, (such as the mobility of the WTRU 250, requested bandwidth, applications, load balancing, subscriber's profile, the measurement reports provided by the WTRU 250, or the like), once the WTRU 250 is within the coverage area of a target RAN.

[0025] Figure 3 is a flow diagram of a process for supporting an E-UTRAN in accordance with the present invention. A WTRU 352 listens to a channel, (e.g., a broadcast control channel (BCCH)), on the UTRAN 354 (step 302). The UTRAN 354 sends, (or indicates), a list of available RATs, (such as E-UTRAN 356 RAT), within the coverage area of the UTRAN 354 to the WTRU 352 (step 304). The list of available RATs is preferably sent via a UTRAN cell information list message. However, the list may be sent via any type of messages. The UTRAN cell information list message contains information on intra-frequency cells, inter-frequency cells and inter-RAT cells. The conventional UTRAN cell information list message is modified to include new information elements (IEs) for the E-UTRAN 356. The E-UTRAN 356 may be based on orthogonal frequency division multiplexing (OFDM), or any other type of air interface. In OFDM case, the UTRAN cell information list may include OFDM selection and reselection information, base transceiver station identity code (BSIC), system specific measurement information, or the like. The system

specific measurement information enumerates supported frequencies, bandwidths, output power, or the like. Table 1 shows an exemplary UTRAN cell information list message including new IEs (shown in bold fonts) in accordance with the present invention.

Information Element/Group name	Need	Multi	Type and reference	Semantics description
Intra-frequency cell info	OP	1..<maxCellMeas>		
>CHOICE <i>position status</i>	MP			
>>Occupied				
>>>Cell info	MP		Cell info 10.3.7.2	
>>Vacant				No data
Inter-frequency cell info	OP	1..<maxCellMeas>		
>CHOICE <i>position status</i>	MP			
>>Occupied				
>>>Frequency info	MP		Frequency info 10.3.6.36	
>>>Cell info	MP		Cell info 10.3.7.2	
>>Vacant				No data
Inter-RAT cell info list	OP			
>Inter-RAT cell info	OP	1..<maxCellMeas>		
>>CHOICE <i>position status</i>	MP			
>>>Occupied				
>>>>CHOICE <i>Radio Access Technology</i>				
>>>>>GSM				
>>>>>>Cell selection and re-selection info	MP		Cell selection and re-selection info for SIB11/12 10.3.2.4	

Table 1 – Part 2 of 2

Information Element/Group name	Need	Multi	Type and reference	Semantics description
>>>>>BSIC	MP		BSIC 10.3.8.2	
>>>>>BCCH ARFCN	MP		Integer (0..1023)	
>>>>>IS-2000				
>>>>>>System specific measurement info			enumerated (frequency, timeslot, colour code, output power, PN offset)	For IS-2000, use fields from TIA/EIA/IS-2000.5, subclause 3. 7.3.3.2.27, <i>Candidate Frequency</i>

Information Element/Group name	Need	Multi	Type and reference	Semantics description
				<i>Neighbour List Message</i>
>>>>OFDM				
>>>>>OFDM selection and re-selection info	MP			
>>>>>BSIC	MP			
>>>>>System Specific measurement info	MP		enumerated (frequency, bandwidth, output power)	
>>>Inter-RAT cell info indicator	OP		Integer (0..3)	
>>Not present				No data

Table 1 – Part 2 of 2

[0026] Referring again to Figure 3, the WTRU 352 receives the list and stores it (step 306). Based on preset user preference, the WTRU 352 sends its multi-mode/multi-RAT capability information to the UTRAN 354 (step 308). The multi-mode/multi-RAT capability information indicates a support of E-UTRAN and/or other RATs. For example, the multi-mode/multi-RAT capability information may indicate a support of OFDM, a support of E-UTRAN to UTRAN handoff, OFDM radio frequency (RF) capability, OFDM measurement capability, or the like. The support of OFDM may enumerate the supported OFDM channel bandwidth, (e.g., 1.25 MHz, 2.5 MHz, 5 MHz, 10 MHz, 15 MHz, 20 MHz). The support of E-UTRAN to UTRAN handoff is preferably a Boolean value indicating such capability of the WTRU.

[0027] The OFDM RF capability and OFDM measurement capability indicate OFDM RF and measurement capabilities of the WTRU to the UTRAN. An OFDM channel may have different bandwidth depending of system configuration and the desired bit rate and delay associated with certain services. For example, in order to achieve the highest bit rate allowed, (e.g., 100 Mbps), the E-UTRAN must transmit and receive using the highest bandwidth allowed, (e.g. 20 MHz). The E-UTRAN may run several combinations of these services (different bandwidths for different WTRUs). Therefore, the handoff to the E-UTRAN should be triggered based on the OFDM RF capabilities of the WTRU. During handoff, when the WTRU performs measurements, the WTRU is

preferably tuned and configured to a certain channel frequency and a specific bandwidth for the measurements. When the WTRU reports the measurements to the UTRAN, the UTRAN correlates the measurements with the physical attributes of the E-UTRAN channels. This guarantees that the handoff is done accurately to the correct target E-UTRAN channel that supports the desired bit rate and delay requirements.

[0028] The multi-mode/multi-RAT capability information may be sent via a conventional UTRAN WTRU multi-mode/multi-RAT capability message, WTRU radio access capability message, WTRU radio access capability extension message, or any other type of message. Tables 2-4 show an exemplary UTRAN WTRU multi-mode/multi-RAT capability message, a WTRU radio access capability message and a WTRU radio access capability extension message, respectively, including new IEs (shown in bold fonts) in accordance with the present invention.

Information Element/Group name	Need	Multi	Type and Reference	Semantics description
Multi-RAT capability				
Support of GSM	MP		Boolean	
Support of multi-carrier	MP		Boolean	
Multi-mode capability	MP		Enumerated (TDD, FDD, FDD/TDD)	
Support of UTRAN to GERAN NACC	CV- <i>not_iRAT_HoInfo</i>		Boolean	
Support OFDM	MP		Enumerated(1.25 M, 2.5M, 5M, 10M, 15M, 20MHz, or range)	
Support E-UTRAN to UTRAN handoffs			Boolean	

Table 2

Information Element/Group name	Need	Multi	Type and reference	Semantics description
Access stratum release indicator	MP		Enumerated(R99)	Indicates the release of the UE. The IE also indicates the release of the RRC transfer syntax supported by the UE..
	CV- <i>not_rrc</i>		Enumerated(REL-4,	13 spare values are needed.

Information Element/Group name	Need	Multi	Type and reference	Semantics description
	<i>_connectionSetupComplete</i>		REL-5 REL-6)	
DL capability with simultaneous HS-DSCH configuration	OP		Enumerated(32kbps, 64kbps, 128kbps, 384kbps)	
PDCP capability	MP		PDCP capability 10.3.3.24	
RLC capability	MP		RLC capability 10.3.3.34	
Transport channel capability	MP		Transport channel capability 10.3.3.40	
RF capability FDD	OP		RF capability FDD 10.3.3.33	
RF capability TDD	OP		RF capability TDD 10.3.3.33b	One "TDD RF capability" entity shall be included for every Chip rate capability supported.
		1 to 2		
RF capability OFDM (E-UTRAN)	OP		OFDM RF capability x.x.x	
Physical channel capability	MP		Physical channel capability 10.3.3.25	
UE multi-mode/multi-RAT capability	MP		UE multi-mode/multi-RAT capability 10.3.3.41	
Security capability	MP		Security capability 10.3.3.37	
UE positioning capability	MP		UE positioning capability 10.3.3.45	
Measurement capability	<i>CH-fdd_req_sup</i>		Measurement capability 10.3.3.21	

Table 3

Information Element/Group name	Need	Multi	Type and reference	Semantics description
Frequency band specific capability list	MP	1 to <maxFreqbands FDD>		
>Frequency band	MP		Enumerated(Band I, Band II, Band III, Band VI, Band IV, Band V, OFDM band)	One spare value is needed

Information Element/Group name	Need	Multi	Type and reference	Semantics description
>Frequency band 2	OP		Enumerated(Extension Indicator OFDM band)	This IE indicates the supported frequency bands beyond Band VIII (yet to be defined) Fifteen spare values are needed
>RF capability FDD extension	MD		RF capability FDD extension 10.3.3.33a	the default values are the same values as in the immediately preceding IE "RF capability FDD extension"; the first occurrence is MP
>Measurement capability extension	MP		Measurement capability extension 10.3.3.21a	
> RF capability OFDM	MD		RF capability OFDM	
> Measurement capability OFDM	MP		Measurement capability OFDM	

Table 4

[0029] Referring again to Figure 3, the UTRAN 354 receives the WTRU multi-mode/multi-RAT capability message (step 310). The UTRAN 354 then sends a measurement capabilities message to the WTRU 352 (step 312). The measurement capability message defines the parameters necessary for the measurements. New IEs for the E-UTRAN are included in the conventional measurement capability message and the measurement capability extension message for the E-UTRAN parameters, (e.g., OFDM measurement parameters for each frequency bands). Each IE in the measurement capability message and the measurement capability extension message is a Boolean value indicating whether downlink or uplink compressed mode is required to perform measurements on each frequency band.

[0030] Tables 5 and 6 show an exemplary UTRAN measurement capability message and a measurement capability extension message, respectively. The new IEs introduced in accordance with the present invention are shown in bold font.

Information Element/Group name	Need	Multi	Type and reference	Semantics description
--------------------------------	------	-------	--------------------	-----------------------

Information Element/Group name	Need	Multi	Type and reference	Semantics description
Need for downlink compressed mode				
FDD measurements	MP		Boolean	TRUE means that the UE requires DL compressed mode in order to perform measurements on FDD
3.84 Mcps TDD measurements	CV- <i>3.84_Mcps_tdd_sup</i>		Boolean	TRUE means that the UE requires DL compressed mode in order to perform measurements on 3.84 Mcps TDD
1.28 Mcps TDD measurements	CV- <i>1.28_Mcps_tdd_sup</i>		Boolean	TRUE means that the UE requires DL compressed mode in order to perform measurements on 1.28 Mcps TDD
GSM measurements	CV- <i>gsm_sup</i>			
>GSM 900	MP		Boolean	TRUE means that the UE requires DL compressed mode in order to perform measurements on GSM 900
>DCS 1800	MP		Boolean	TRUE means that the UE requires DL compressed mode in order to perform measurements on DCS 1800
>GSM 1900	MP		Boolean	TRUE means that the UE requires DL compressed mode in order to perform measurements on GSM 1900
Multi-carrier measurement	CV- <i>mc_sup</i>		Boolean	TRUE means that the UE requires DL compressed mode in order to perform measurements on multi-carrier
OFDM E-UTRAN measurements				
>1.25 MHz	MP		Boolean	TRUE means that the UE requires DL compressed mode in order to perform measurements on 1.25 MHz OFDM
>2.5 MHz	MP		Boolean	TRUE means that the UE requires DL compressed mode in order to perform measurements on 2.5 MHz OFDM
>5 MHz	MP		Boolean	TRUE means that the UE requires DL compressed mode in order to perform measurements on 5 MHz OFDM
>10 MHz	MP		Boolean	TRUE means that the UE requires DL compressed mode in order to perform measurements on 10 MHz OFDM

Table 5 – Part 1 of 3

Information Element/Group name	Need	Multi	Type and reference	Semantics description
>15 MHz	MP		Boolean	TRUE means that the UE requires DL compressed mode in order to perform measurements on 15 MHz OFDM
>20 MHz	MP		Boolean	TRUE means that the UE requires DL compressed mode in order to perform measurements on 20 MHz OFDM
Need for uplink compressed mode				
FDD measurements	MP		Boolean	TRUE means that the UE requires UL compressed mode in order to perform measurements on FDD
3.84 Mcps TDD measurements	CV- <i>3.84_Mcps_tdd_sup</i>		Boolean	TRUE means that the UE requires UL compressed mode in order to perform measurements on 3.84 Mcps TDD
1.28 Mcps TDD measurements	CV- <i>1.28_Mcps_tdd_sup</i>		Boolean	TRUE means that the UE requires DL compressed mode in order to perform measurements on 1.28 Mcps TDD
GSM measurements	CV- <i>gsm_sup</i>			
>GSM 900	MP		Boolean	TRUE means that the UE requires UL compressed mode in order to perform measurements on GSM 900
>DCS 1800	MP		Boolean	TRUE means that the UE requires UL compressed mode in order to perform measurements on DCS 1800
>GSM 1900	MP		Boolean	TRUE means that the UE requires UL compressed mode in order to perform measurements on GSM 1900
Multi-carrier measurement	CV- <i>mc_sup</i>		Boolean	TRUE means that the UE requires UL compressed mode in order to perform measurements on multi-carrier
OFDM E-UTRAN measurements				
>1.25 MHz	MP		Boolean	TRUE means that the UE requires UL compressed mode in order to perform measurements on 1.25 MHz OFDM
>2.5 MHz	MP		Boolean	TRUE means that the UE requires UL compressed mode in order to perform measurements on 2.5 MHz OFDM
>5 MHz	MP		Boolean	TRUE means that the UE requires UL compressed mode in order to perform measurements on 5 MHz OFDM

Table 5 – Part 2 of 3

Information Element/Group name	Need	Multi	Type and reference	Semantics description
>10 MHz	MP		Boolean	TRUE means that the UE requires UL compressed mode in order to perform measurements on 10 MHz OFDM
>15 MHz	MP		Boolean	TRUE means that the UE requires UL compressed mode in order to perform measurements on 15 MHz OFDM
>20 MHz	MP		Boolean	TRUE means that the UE requires UL compressed mode in order to perform measurements on 20 MHz OFDM

Table 5 – Part 3 of 3

Information Element/Group name	Need	Multi	Type and reference	Semantics description
FDD measurements	MP	1 to <maxFreqBandsFDD>		
>FDD Frequency band	MD		Enumerated(Band I, Band II, Band III, Band VI, Band IV, Band V)	The default value is the same as indicated in the IE "Frequency band" included in the IE " UE radio access capability extension". One spare value is needed
				The default value is the same as R99, if the IE "FDD Frequency band 2" below is not included. The default value is the same as the IE "FDD Frequency band 2", if the IE "FDD Frequency band 2" is included.
>FDD Frequency band 2	MD		Enumerated(Extension Indicator)	The default value is the same as indicated in the IE "Frequency band 2" included in the IE " UE radio access capability extension"., if the IE "FDD Frequency band" above is not included. The default value is the same as the IE "FDD Frequency band", if the IE "FDD Frequency band" is included. Fifteen spare values are needed

Table 6 – Part 1 of 4

Information Element/Group name	Need	Multi	Type and reference	Semantics description
>Need for DL compressed mode	MP		Boolean	TRUE means that the UE requires DL compressed mode in order to perform measurements on the FDD frequency band indicated by the IE "FDD Frequency band"
>Need for UL compressed mode	MP		Boolean	TRUE means that the UE requires UL compressed mode in order to perform measurements on the FDD frequency band indicated by the IE "FDD Frequency band"
TDD measurements	CV- <i>tdd_sup</i>	1 to <maxFreqBandsTDD>		
>TDD Frequency band	MP		Enumerated(a, b, c)	
>Need for DL compressed mode	MP		Boolean	TRUE means that the UE requires DL compressed mode in order to perform measurements on TDD frequency band indicated by the IE "TDD Frequency band"
>Need for UL compressed mode	MP		Boolean	TRUE means that the UE requires UL compressed mode in order to perform measurements on TDD frequency band indicated by the IE "TDD Frequency band"
GSM measurements	CV- <i>gsm_sup</i>	1 to <maxFreqBandsGSM>		
>GSM Frequency band	MP		Enumerated(GSM450, GSM480, GSM850, GSM900P, GSM900E, GSM1800, GSM1900)	Nine spare values are needed.
>Need for DL compressed mode	MP		Boolean	TRUE means that the UE requires DL compressed mode in order to perform measurements on GSM frequency band indicated by the IE "GSM Frequency band"

Table 6 – Part 2 of 4

Information Element/Group name	Need	Multi	Type and reference	Semantics description
>Need for UL compressed mode	MP		Boolean	TRUE means that the UE requires UL compressed mode in order to perform measurements on GSM frequency band indicated by the IE "GSM Frequency band"
Multi-carrier measurement	CV- mc_s up			
>Need for DL compressed mode	MP		Boolean	TRUE means that the UE requires DL compressed mode in order to perform measurements on multi-carrier
>Need for UL compressed mode	MP		Boolean	TRUE means that the UE requires UL compressed mode in order to perform measurements on multi-carrier
OFDM E-UTRAN measurements				
> 1.25 MHz band	MP		Enumerated(x, y, z)	
>Need for DL compressed mode	MP		Boolean	TRUE means that the UE requires DL compressed mode in order to perform measurements on 1.25 MHz OFDM
>Need for UL compressed mode	MP		Boolean	TRUE means that the UE requires UL compressed mode in order to perform measurements on 1.25 MHz OFDM
>> 2.5 MHz band	MP		Enumerated(x, y, z)	
>Need for DL compressed mode	MP		Boolean	TRUE means that the UE requires DL compressed mode in order to perform measurements 2.5 MHz OFDM
>Need for UL compressed mode	MP		Boolean	TRUE means that the UE requires UL compressed mode in order to perform measurements on 2.5 MHz OFDM
>> 5 MHz band	MP		Enumerated(x, y, z)	
>Need for DL compressed mode	MP		Boolean	TRUE means that the UE requires DL compressed mode in order to perform measurements 2.5 MHz OFDM
>Need for UL compressed mode	MP		Boolean	TRUE means that the UE requires UL compressed mode in order to perform measurements on 5 MHz OFDM

Table 6 – Part 3 of 4

Information Element/Group name	Need	Multi	Type and reference	Semantics description
>> 10 MHz band	MP		Enumerated(x, y, z)	
>Need for DL compressed mode	MP		Boolean	TRUE means that the UE requires DL compressed mode in order to perform measurements 10 MHz OFDM
>Need for UL compressed mode	MP		Boolean	TRUE means that the UE requires UL compressed mode in order to perform measurements on 10 MHz OFDM
>> 15 MHz band	MP		Enumerated(x, y, z)	
>Need for DL compressed mode	MP		Boolean	TRUE means that the UE requires DL compressed mode in order to perform measurements 15 MHz OFDM
>Need for UL compressed mode	MP		Boolean	TRUE means that the UE requires UL compressed mode in order to perform measurements on 15 MHz OFDM
>> 20 MHz band	MP		Enumerated(x, y, z)	
>Need for DL compressed mode	MP		Boolean	TRUE means that the UE requires DL compressed mode in order to perform measurements 20 MHz OFDM
>Need for UL compressed mode	MP		Boolean	TRUE means that the UE requires UL compressed mode in order to perform measurements on 20 MHz OFDM

Table 6 – Part 4 of 4

[0031] Referring again to Figure 3, the WTRU 352 receives the measurement capabilities message. The WTRU 352 then performs measurements on the E-UTRAN signals 315 on E-UTRAN channels indicated in the measurement capabilities message and reports measurement results to the UTRAN 354 (step 314). The UTRAN 354 may initiate a handoff to the E-UTRAN 356 based on the measurement reports.

[0032] Embodiments - I

[0033] A method for supporting an E-UTRAN in a wireless communication system including a WTRU, a UTRAN and the E-UTRAN.

[0034] The method comprising the step of the WTRU listening to a UTRAN channel.

[0035] The method comprising the step of the UTRAN sending a list of available RATs in a coverage area of the UTRAN via the UTRAN channel, the

list including information related to the E-UTRAN.

[0036] The method comprising the step of the WTRU receiving the list, whereby the WTRU receives E-UTRAN services based on the list.

[0037] The method wherein the list is sent via a BCCH.

[0038] The method wherein the list is included in a cell information list message.

[0039] The method wherein the list is sent via a dedicated channel.

[0040] The method wherein a RAT of the E-UTRAN is OFDM.

[0041] The method wherein the E-UTRAN information includes at least one of OFDM selection and reselection information, BSIC, and system specific measurement information.

[0042] The method wherein the system specific measurement information enumerates at least one of supported frequency, bandwidth, and output power.

[0043] The method comprising the step of the WTRU sending a multi-mode/multi-RAT capability of the WTRU to the UTRAN.

[0044] The method comprising the step of the UTRAN receiving the multi-mode/multi-RAT capability of the WTRU.

[0045] The method wherein the multi-mode/multi-RAT capability indicates an E-UTRAN capability of the WTRU.

[0046] The method wherein the E-UTRAN capability includes an OFDM capability.

[0047] The method wherein the multi-mode/multi-RAT capability includes at least one of an indication of OFDM support, an indication of a support of handoff between the UTRAN and the E-UTRAN, OFDM radio frequency capability, and OFDM measurement capability.

[0048] The method wherein the indication of OFDM support enumerates supported frequencies and bandwidths.

[0049] The method wherein the multi-mode/multi-RAT capability is sent via at least one of a WTRU multi-mode/multi-RAT capability message, a WTRU radio access capability message, and a WTRU radio access capability extension message.

- [0050] The method wherein the multi-mode/multi-RAT capability is sent during an attach procedure.
- [0051] The method wherein the multi-mode/multi-RAT capability is sent upon request by the UTRAN.
- [0052] The method comprising the step of the UTRAN sending a measurement capability message to the WTRU, the measurement capability message including parameters necessary for performing measurements on an E-UTRAN channel.
- [0053] The method comprising the step of the WTRU performing measurements based on the measurement capability message.
- [0054] The method comprising the step of the WTRU reporting measurement results to the UTRAN.
- [0055] The method comprising the step of the UTRAN initiating a handoff of the WTRU to the E-UTRAN based on the measurement results.
- [0056] The method wherein the measurement capability message includes parameters for OFDM measurements.
- [0057] The method comprising the step of the WTRU initiating a handoff from the UTRAN to the E-UTRAN based on the list.
- [0058] The method wherein the handoff is triggered by a user of the WTRU.
- [0059] The method wherein the handoff is triggered automatically.
- [0059A] Embodiments - II
- [0060] A wireless communication system supporting an E-UTRAN.
- [0061] The system comprising an E-UTRAN.
- [0062] The system comprising a UTRAN configured to send a list of available RATs in a coverage area of the UTRAN, the list including information related to the E-UTRAN.
- [0063] The system comprising a WTRU configured to receive the list and receive E-UTRAN services based on the list.
- [0064] The system wherein the UTRAN sends the list via a BCCH.
- [0065] The system wherein the UTRAN includes the list in a cell

information list message.

[0066] The system wherein the UTRAN sends the list via a dedicated channel.

[0067] The system wherein an RAT of the E-UTRAN is OFDM.

[0068] The system wherein the E-UTRAN information includes at least one of OFDM selection and reselection information, BSIC, and system specific measurement information.

[0069] The system wherein the system specific measurement information enumerates at least one of supported frequency, bandwidth, and output power.

[0070] The system wherein the WTRU is configured to send its multi-mode/multi-RAT capability to the UTRAN.

[0071] The system wherein the multi-mode/multi-RAT capability includes E-UTRAN capability.

[0072] The system wherein the E-UTRAN capability includes an OFDM capability.

[0073] The system wherein the multi-mode/multi-RAT capability includes at least one of an indication of OFDM support, an indication of a support of handoff between the UTRAN and the E-UTRAN, OFDM radio frequency capability, and OFDM measurement capability.

[0074] The system wherein the indication of OFDM support enumerates supported frequencies and bandwidths.

[0075] The system wherein the multi-mode/multi-RAT capability is sent via at least one of a WTRU multi-mode/multi-RAT capability message, a WTRU radio access capability message, and a WTRU radio access capability extension message.

[0076] The system wherein the multi-mode/multi-RAT capability is sent during an attach procedure.

[0077] The system wherein the multi-mode/multi-RAT capability is sent upon request by the UTRAN.

[0078] The system wherein the UTRAN is configured to send a measurement capability message to the WTRU, the measurement capability

message including parameters necessary to perform measurements on an E-UTRAN channel, and the WTRU is configured to perform measurements based on the measurement capability message and report measurement results to the UTRAN.

[0079] The system wherein the UTRAN is configured to initiate a handoff to the E-UTRAN based on the measurement results.

[0080] The system wherein the measurement capability message includes parameters for OFDM measurements.

[0081] The system wherein the WTRU is configured to initiate a handoff of the WTRU from the UTRAN to the E-UTRAN based on the list.

[0082] The system wherein the handoff is triggered by a user of the WTRU.

[0083] The system wherein the handoff is triggered automatically.

[0084] Although the features and elements of the present invention are described in the preferred embodiments in particular combinations, each feature or element can be used alone without the other features and elements of the preferred embodiments or in various combinations with or without other features and elements of the present invention.

CLAIMS

What is claimed is:

1. A method for use in a wireless transmit/receive unit (WTRU), the method comprising:

receiving a first message from a universal mobile telecommunication systems (UMTS) terrestrial radio access network (UTRAN) base station via a first UTRAN channel;

extracting a first information element (IE) associated with an Evolved-UTRAN (E-UTRAN) from the first message;

generating a second message indicating E-UTRAN capability information, wherein the E-UTRAN capability information includes an indication of support for an orthogonal frequency division multiplex (OFDM) mode and support UTRAN to E-UTRAN handover;

transmitting the second message to the UTRAN base station via a second UTRAN channel; and

receiving an E-UTRAN service based on the second message.

2. The method of claim 1, wherein the second message indicates a supported E-UTRAN frequency band.

3. The method of claim 1, wherein the second message is one of a multi-mode/multi-Radio Access Technology (RAT) capability message, a radio access capability message, or a radio access capability extension message.

4. A wireless transmit/receive unit (WTRU), comprising:

a receiver configured to receive a first message from a universal mobile telecommunication systems (UMTS) terrestrial radio access network (UTRAN) base station via a first UTRAN channel;

a processor configured to extract a first information element (IE) associated with an Evolved-UTRAN (E-UTRAN) from the first message; and to generate a second message indicating E-UTRAN capability information, wherein

the E-UTRAN capability information includes an indication of support for an orthogonal frequency division multiplex (OFDM) mode and support for UTRAN to E-UTRAN handover;

a transmitter configured to transmit the second message to the UTRAN base station via a second UTRAN channel; and

the receiver configured to receive an E-UTRAN service based on the second message.

5. The WTRU of claim 4, wherein the processor is configured to indicate a supported E-UTRAN frequency band in the second message.

6. The WTRU of claim 4, wherein the second message is one of a multi-mode/multi-RAT capability message, a radio access capability message, a radio access capability extension message.

7. An integrated circuit comprising:

circuitry configured to receive, from a receiver, a first message received from a universal mobile telecommunication systems (UMTS) terrestrial radio access network (UTRAN) base station via a first UTRAN channel;

circuitry configured to extract a first information element (IE) associated with an Evolved-UTRAN (E-UTRAN) from the first message;

circuitry configured to generate a second message indicating E-UTRAN capability information, wherein the E-UTRAN capability information includes an indication of support for an orthogonal frequency division multiplex (OFDM) mode and support for UTRAN to E-UTRAN handover;

circuitry configured to output the second message to a transmitter for transmission to the UTRAN base station via a second UTRAN channel; and

circuitry configured to receive, from the receiver, an E-UTRAN service based on the second message.

8. The integrated circuit of claim 7, wherein the second message indicates a supported E-UTRAN frequency band.

9. The integrated circuit of claim 7, wherein the second message is one of a multi-mode/multi-RAT capability message, a radio access capability message, or a radio access capability extension message.

10. A method for use in a base station, the method comprising:
generating a first message that includes an information element (IE) associated with an Evolved Universal Mobile Telecommunication System (UMTS) radio access network (E-UTRAN);

transmitting the first message to a wireless transmit/receive unit (WTRU) via a first UTRAN channel; and

receiving a second message from a WTRU via a second UTRAN channel, the second message indicating E-UTRAN capability information that includes an indication of support for an orthogonal frequency division multiplex (OFDM) mode and support for UTRAN to E-UTRAN handover, to enable the WTRU to receive an E-UTRAN service based on the second message.

11. The method of claim 10, wherein the second message indicates a supported E-UTRAN frequency band.

12. The method of claim 10, wherein the second message is one of a multi-mode/multi-RAT capability message, a radio access capability message, or a radio access capability extension message.

13. A base station for use in wireless communications comprising:
a processor configured to generate a first message that includes an information element (IE) associated with an Evolved Universal Mobile Telecommunication System (UMTS) radio access network (E-UTRAN);

a transmitter configured to transmit the first message to a wireless transmit/receive unit (WTRU) via a first UTRAN channel; and

a receiver configured to receive a second message from a WTRU via a second UTRAN channel, the second message indicating E-UTRAN capability information that includes an indication of support for an orthogonal frequency division multiplex (OFDM) mode and support for UTRAN to E-UTRAN handover, to enable the WTRU to receive an E-UTRAN service based on the second message.

14. The base station of claim 13, wherein the second message indicates a supported E-UTRAN frequency band.

15. The base station of claim 13, wherein the second message is one of a multi-mode/multi-RAT capability message, a radio access capability message, or a radio access capability extension message.

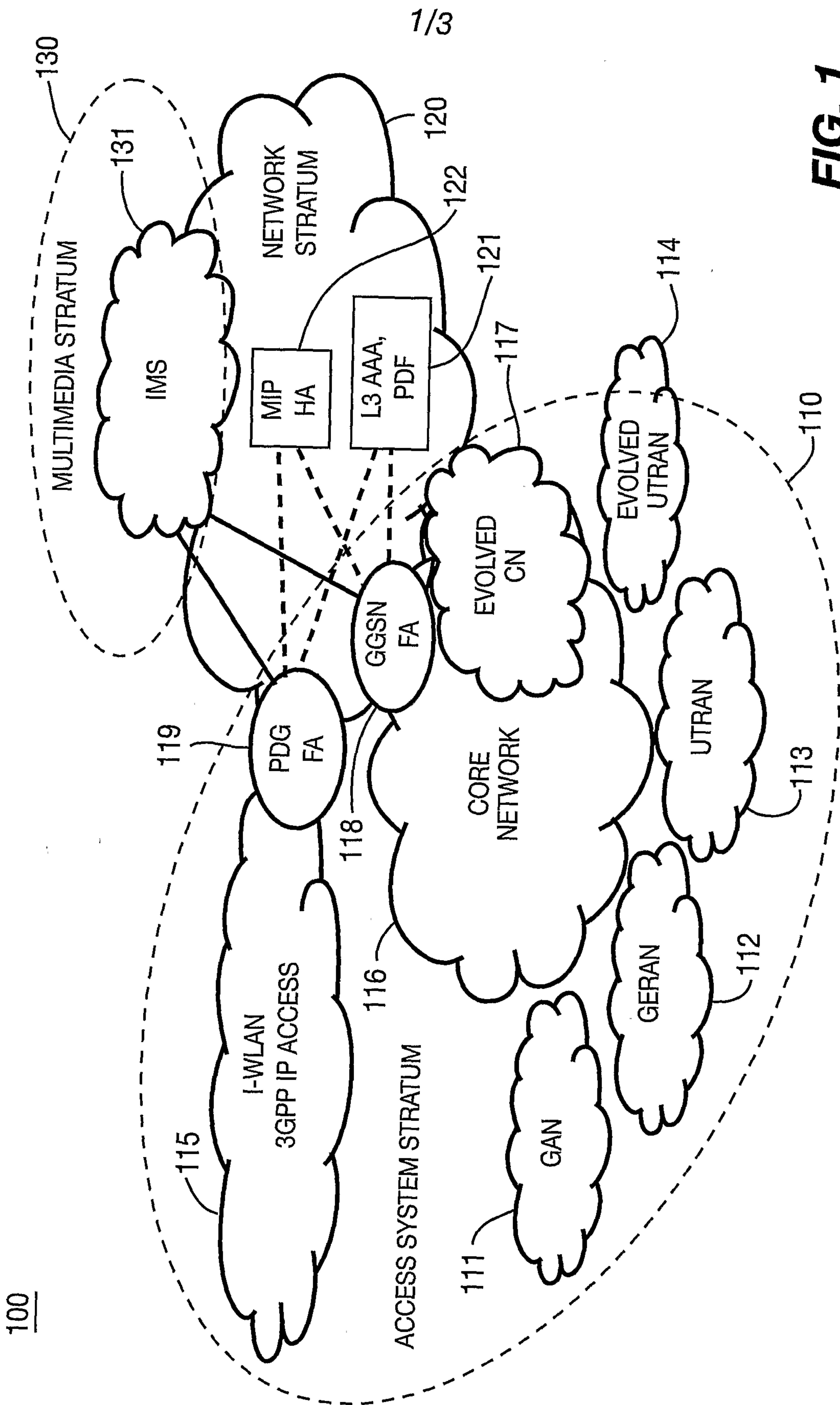

FIG. 1
PRIOR ART

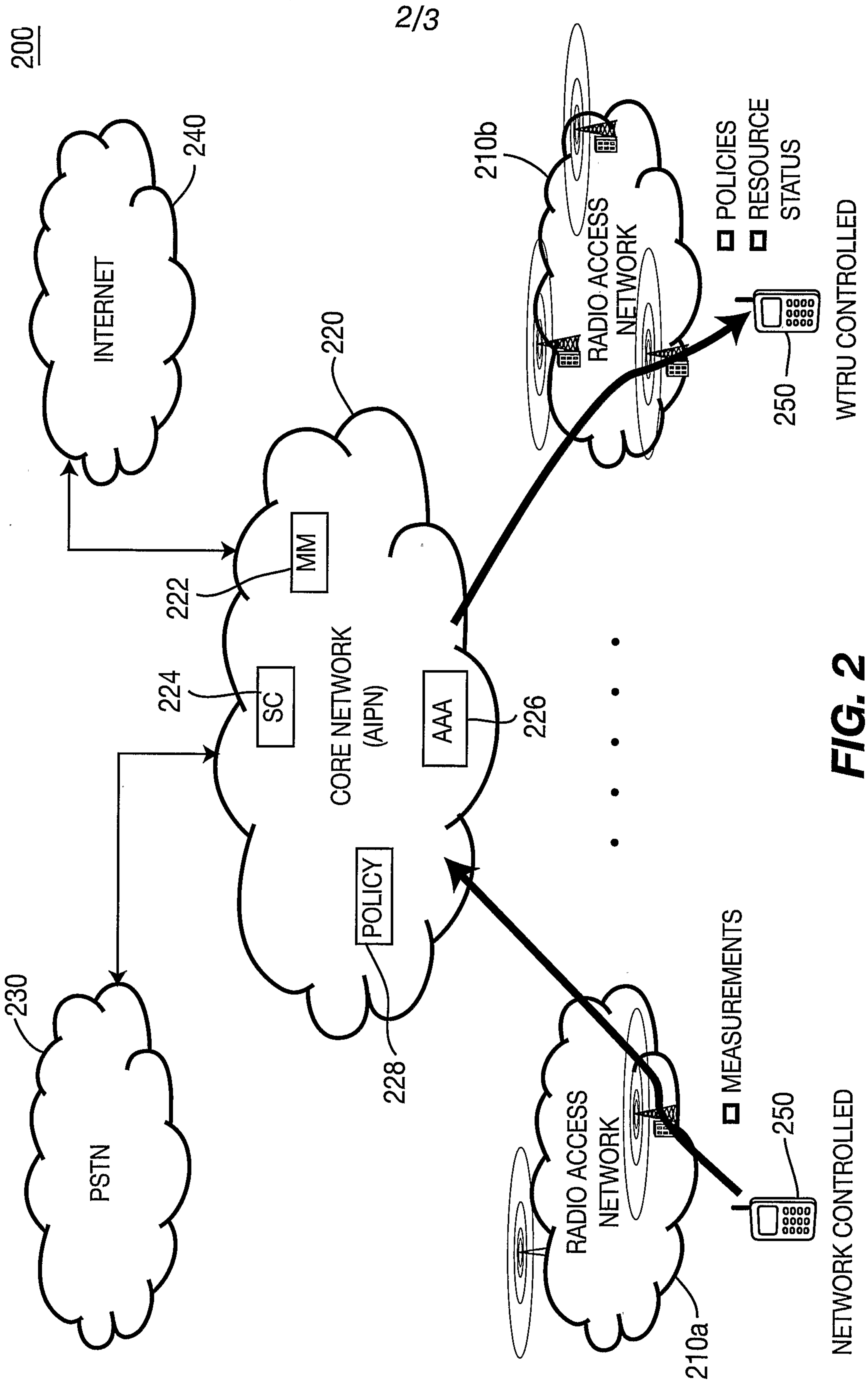

FIG. 2

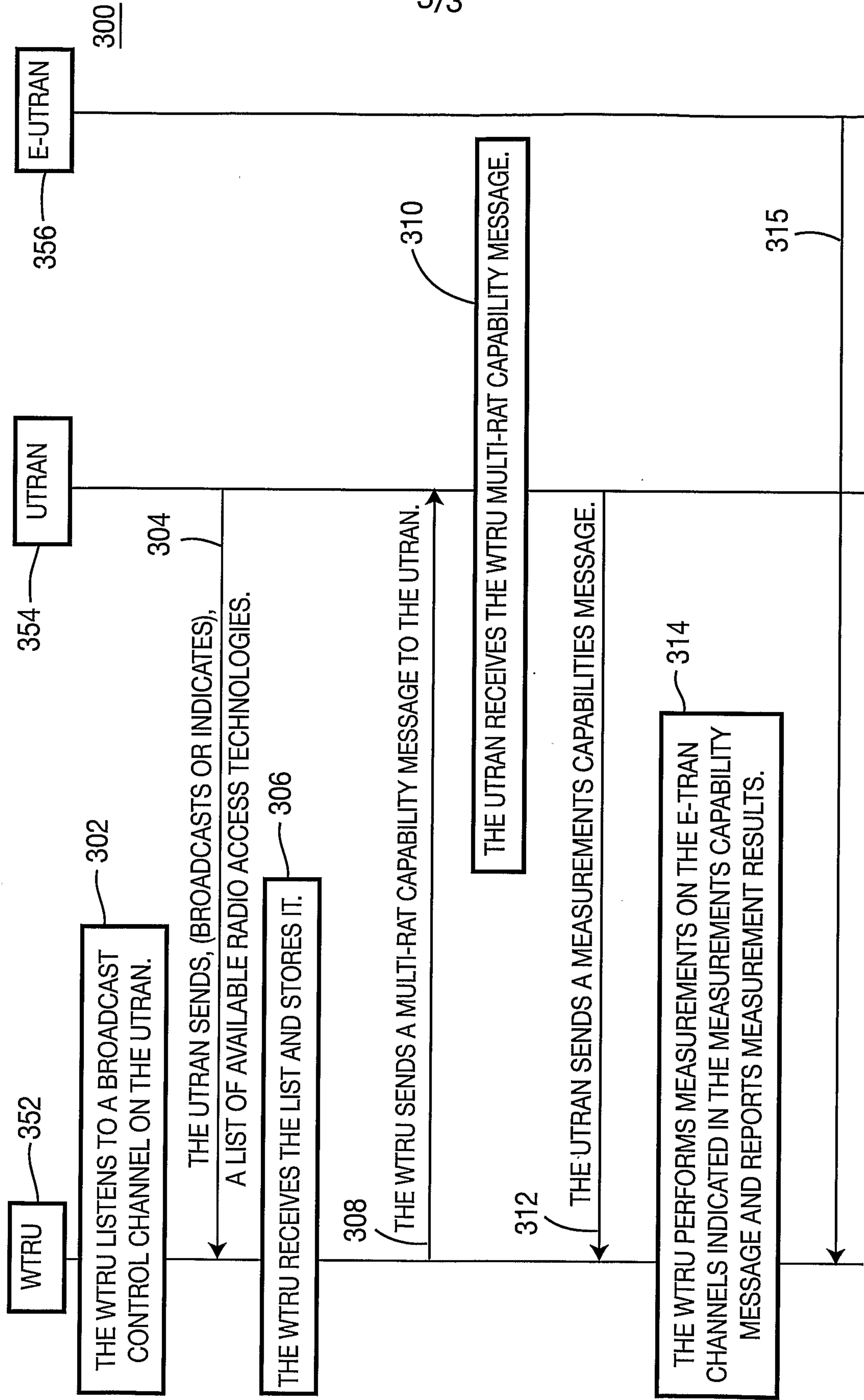

FIG. 3

