

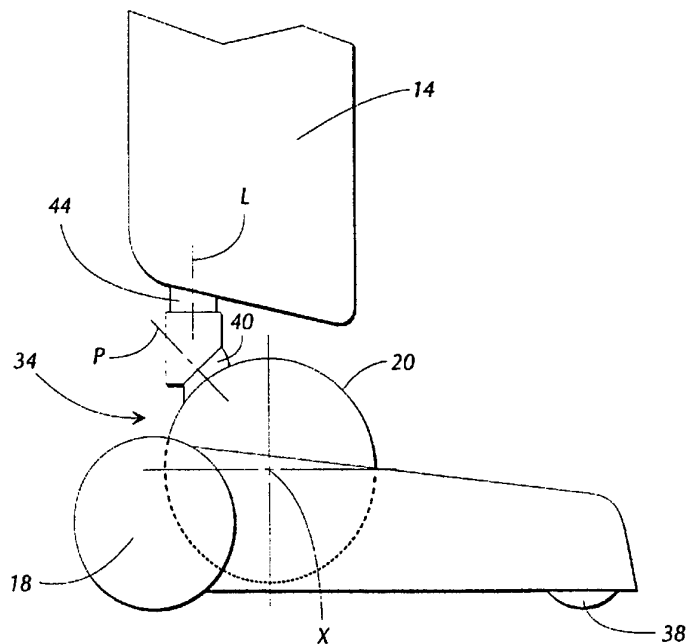

INTERNATIONAL APPLICATION PUBLISHED UNDER THE PATENT COOPERATION TREATY (PCT)

<p>(51) International Patent Classification⁵ : A47L 9/32</p>	<p>A1</p>	<p>(11) International Publication Number: WO 95/01748 (43) International Publication Date: 19 January 1995 (19.01.95)</p>
<p>(21) International Application Number: PCT/US94/07148 (22) International Filing Date: 24 June 1994 (24.06.94) (30) Priority Data: 089,978 9 July 1993 (09.07.93) US (71) Applicant: THE REGINA COMPANY [US/US]; Suite 400, 1955 Lake Park Drive, Smyrna, GA 30080 (US). (72) Inventors: REDDING, Glenn, Kendal; 12540 Quail Ridge Road, Gulfport, MI 39503 (US). SPROW-BYRD, Kris- ten, G.; 3907 Belmede Place, Gulfport, MI 39507 (US). COLLINS, Michael, Darter; Apartment D13, 1550 E. 2nd Street, Pass Christian, MI 39571 (US). HUNTER, James, Ross, Jr.; Apartment S116, 1550 E. 2nd Street, Pass Chris- tian, MI 39571 (US). MILLER, Gary, Allen; 15283 Woody Drive, Gulfport, MI 39503 (US). ROBINETTE, Christo- pher, Alan; 1490 Valota Road, Redwood City, CA 94061 (US). WEBB, Walter, Lee; 615 Parkwood Drive, Long Beach, MI 39560 (US). (74) Agents: GRONHOLM, Gregory, T. et al.; Jones & Askew, 37th floor, 191 Peachtree Street, N.E., Atlanta, GA 30303-1769 (US).</p>		<p>(81) Designated States: CA, JP, European patent (AT, BE, CH, DE, DK, ES, FR, GB, GR, IE, IT, LU, MC, NL, PT, SE). Published <i>With international search report.</i></p>

(54) Title: VACUUM CLEANER HAVING IMPROVED STEERING FEATURES



(57) Abstract

An upright steerable vacuum cleaner (10) is provided, which includes the use of a pivotable cylindrical motor housing (12), as well as a universal joint (34) which is attached to the motor housing (12), such that twisting at the upper body (24) of the vacuum cleaner clockwise causes the base of the unit (12) to turn right, and twisting in the opposite direction causes it to turn left.

FOR THE PURPOSES OF INFORMATION ONLY

Codes used to identify States party to the PCT on the front pages of pamphlets publishing international applications under the PCT.

AT	Austria	GB	United Kingdom	MR	Mauritania
AU	Australia	GE	Georgia	MW	Malawi
BB	Barbados	GN	Guinea	NE	Niger
BE	Belgium	GR	Greece	NL	Netherlands
BF	Burkina Faso	HU	Hungary	NO	Norway
BG	Bulgaria	IE	Ireland	NZ	New Zealand
BJ	Benin	IT	Italy	PL	Poland
BR	Brazil	JP	Japan	PT	Portugal
BY	Belarus	KE	Kenya	RO	Romania
CA	Canada	KG	Kyrgystan	RU	Russian Federation
CF	Central African Republic	KP	Democratic People's Republic of Korea	SD	Sudan
CG	Congo	KR	Republic of Korea	SE	Sweden
CH	Switzerland	KZ	Kazakhstan	SI	Slovenia
CI	Côte d'Ivoire	LI	Liechtenstein	SK	Slovakia
CM	Cameroon	LK	Sri Lanka	SN	Senegal
CN	China	LU	Luxembourg	TD	Chad
CS	Czechoslovakia	LV	Latvia	TG	Togo
CZ	Czech Republic	MC	Monaco	TJ	Tajikistan
DE	Germany	MD	Republic of Moldova	TT	Trinidad and Tobago
DK	Denmark	MG	Madagascar	UA	Ukraine
ES	Spain	ML	Mali	US	United States of America
FI	Finland	MN	Mongolia	UZ	Uzbekistan
FR	France			VN	Viet Nam
GA	Gabon				

5

1

VACUUM CLEANER HAVING IMPROVED STEERING FEATURES

10

Technical Field

This invention relates in general to vacuum cleaners, and particularly relates to vacuum cleaners which have an improved "steering" feature.

15

Background of the Invention

In the field of vacuum cleaners, a need has been recognized to provide vacuum cleaners which have improved maneuverability features. The prior art is replete with powered upright vacuum cleaners and vacuum cleaners which include L-shaped nozzles which allow the operator to vacuum around objects such as chair legs.

20

However, a need still exists for an upright vacuum cleaner which has improved maneuverability features not provided by the prior art.

25

Summary of the Invention

30

The present invention provides an improved upright vacuum cleaner which has improved maneuverability features, and which is cost-effective to produce, operate, and maintain.

It is an object of the present invention to provide an improved vacuum cleaner.

It is an object of the present invention to provide a vacuum cleaner which has improved cleaning features.

It is an object of the present invention to provide a vacuum cleaner which has improved maneuverability features.

5 It is an object of the present invention to provide a vacuum cleaner which is easy to operate.

It is an object of the present invention to provide a vacuum cleaner which is cost-effective to produce.

10 Other objects, features, and advantages of the present invention will become apparent upon reading the following detailed description of the preferred embodiment of the invention when taken in conjunction with the drawing and the appended claims.

15

Brief Description of the Drawings

Figure 1 is a front, right, pictorial view of a first embodiment of an upright vacuum cleaner according to the present invention.

20 Figure 2 is a rear, right view of the upright vacuum cleaner illustrated in Figure 1.

Figure 3 is an exploded view illustrating some elements of the base of the vacuum cleaner shown in Figure 1.

25 Figures 4 and 5 are additional embodiments of a base of the vacuum cleaner according to the present invention, including an alternate preferred universal joint assembly.

Figure 6 is a side illustrative view of that shown in Figure 4.

30 Figure 7 is an upper right pictorial view of the universal joint being part of the present invention.

Figure 8 is right side exploded view of that shown in Figure 7.

Figure 9 is a front exploded view of that shown in Figure 7.

Figure 10 is an illustrative view of an alternate universal joint member not including the use of an intermediate collar.

5 **Detailed Description of the Preferred Embodiment**

Referring now to the Figures, in which like numerals indicate like parts throughout the several views, Figure 1 illustrates an upright vacuum cleaner 10 including a lower base 12 and an upright body 14. The base 12 includes a height adjustment switch 16, and a pair of rear wheels 18. The base 12 also includes a cylindrically-shaped motor housing 20. The upright body 14 may include a light 22, and an upright handle portion 24.

Referring now also to Figure 2, hose assembly 26, tools 28, cord wrap flanges 30, 32, and upper and lower universal joint subassembly 34 are shown.

Referring now to Figure 3, some of the previously discussed elements are illustrated, along with a front roller 38.

Referring now to Figures 4 and 5, various base configurations are shown.

Referring now to Figures 6-9, a side view of one embodiment of the universal joint assembly 34 is illustrated. Operation of this assembly 34 is now discussed. As may be understood, an upper universal joint member 44 is rotatably mounted relative to lower universal joint member 40 along a pivoting axis P. These members are joined by an intermediate collar 42 such that air can be transferred from member 40 to member 44. The upper universal joint member 44 is rigidly attached relative to body member 14 and facilitates the transfer of air into the body through an internal air channel. Lower universal joint member 42 is likewise rigidly affixed relative to cylindrically-shaped motor housing 20 and receives air from a motor within the housing 20. The motor housing 20 is pivotably mounted relative to the base 12 of the vacuum cleaner, along substantially horizontal axis X. Intermediate

collar 42, in the embodiment shown is composed of two halves joined together by fasteners such as is known in the art.

As may be understood, the lower universal joint member 40 has an annular tapered "male" portion 50 (see Fig. 8) which fits within an annular tapered "female" portion 52 (see Fig. 9) of the upper universal joint member 44. The intermediate collar 42 locks these two elements 40, 44, together such that they may rotate relative to each other along axis P (see Fig. 6) described above, and at the same time air may be transferred from member 40 to member 44.

The intermediate linking collar 42, when in place, is rotatably mounted to the lower universal joint member by means of outwardly-directed annular ribs 54 (see Fig. 8) of the lower universal member mating with a single inwardly-directed annular ring (not shown) inside the collar 42, allowing the collar to rotate along axis P relative to the lower universal joint member 40, but limiting movement of the two members along axis P. By a similar interlocking relationship provided by outwardly-directed annular ribs 56 of the upper universal member mating with mating with a single inwardly-directed rib (not shown) in the collar, the collar 42 is rotatably mounted relative to the upper universal joint member 44, with the two elements allowed to rotate relative to each other along axis L.

Other universal joint configurations are also contemplated under the present invention. For example, as shown in Figure 10 an alternate universal joint configuration is contemplated in which, for example, a lower universal member 62 (which is assembled from two halves and attached by fasteners as known in the art) interlocks with an upper universal joint member 60 without the use of a collar. The upper and lower members would be rotatably interlocked by the use of interlocking annular ribs on the two members providing interlocking of the members as described above. The lower universal joint member, being a "female" member

62, accepts and surrounds the lower end of the upper universal joint member, being a "male" member, providing for rotational or relative pivoting movement of the two members about an axis such as "P", described above, with travel along the axis being limited by the interference of the annular ribs. Member 62 is attached to the pivoting motor housing and member 60 is attached to the upper body in a manner similar to that described above.

As may be understood, when the operator operates the upright vacuum cleaner, the operator first pivots the upright body 14 from its relatively vertical position illustrated in Figure 6 to a more inclined position. As the vacuum cleaner is operated, if the operator is pushing the vacuum cleaner generally forward, the operator may "twist" the handle to cause the handle and body to turn in a clockwise or counterclockwise direction substantially along their longitudinal axes. In the instance of the configuration illustrated in Figure 6, if the operator twists the body 12 in a clockwise direction along its longitudinal axis, the base 12 will tend to turn to the right as it is being pushed forwardly. Likewise, if the body 14 is rotated in a counter-clockwise direction along their longitudinal axis, the base 12 will tend to turn leftwardly as it is being pushed in a forward direction. As may be understood, such a configuration is an improvement over the prior art in that by a continuation of pushing and twisting the handle of the vacuum cleaner, the base may be simply and easily maneuvered in a novel manner.

The air flow throughout the unit is as follows. A motor within the motor housing 20 is energized, such that air is drawn from beneath the base 12, into the motor housing through a suitable connection, into the lower universal member, into the upper universal member, and into the body and into a filtration bag or canister.

While this invention has been described in specific detail with reference to the disclosed embodiments, it will be

6

understood that many variations and modifications may be effected within the spirit and scope of the invention as described in the appended claims.

Claims

What is claimed is:

- 5 1. A vacuum cleaner, comprising:
 a base;
 a motor housing pivotally attached to said base about a
 substantially horizontal first axis;
 a substantially upright elongate body portion including a
10 handle portion; and
 a universal joint assembly defining an air channel
 capable of facilitating the flow of air from said base to said
 body portion, said joint assembly itself comprising;
 a) an upper universal joint portion rigidly
15 attached to said body portion;
 b) a lower universal joint portion rigidly affixed
 to said motor housing; and
 c) link means for linking said upper universal
20 joint member to said lower universal joint member such that
 said upper body member may be rotated along a second axis
 relative to said motor housing, such that twisting said upper
 body member clockwise along said longitudinal axis while
 pushing said vacuum cleaner forward tends to cause said
25 vacuum cleaner base to turn right, and twisting said upper
 body member counterclockwise along said longitudinal axis
 while pushing said vacuum cleaner forward tends to cause said
 vacuum cleaner base to turn left.
- 30 2. The vacuum cleaner as claimed in Claim 1, wherein said
 motor housing may be selectively locked and unlocked relative
 to said base such that said pivoting relationship between said
 motor housing and said base may be correspondingly
 disallowed and allowed.

3. The vacuum cleaner as claimed in Claim 1, wherein said first pivoting axis between said motor housing and said base is substantially orthogonal to said second pivoting axis between said motor housing and said body of said vacuum cleaner.

5

4. The vacuum cleaner as claimed in Claim 1, wherein said link means is a collar which fits over and locks to said upper and lower universal members.

10

5. The vacuum cleaner as claimed in Claim 4, wherein said collar is attached to said upper universal member by an annular locking relationship, and wherein said collar is attached to said lower universal joint by an annular locking relationship, such that said twisting action causes said collar to rotate along an axis relative to at least one of said upper and lower universal joint members.

15

6. The vacuum cleaner of Claim 5, wherein said collar is rotatably mounted to said lower universal member about said second axis.

20

7. The vacuum cleaner of Claim 1, wherein said link means is provided by at least one annular locking rib extending inwardly from said lower universal joint member, and interlocking with at least one annular locking rib extending outwardly from said upper universal joint member.

25

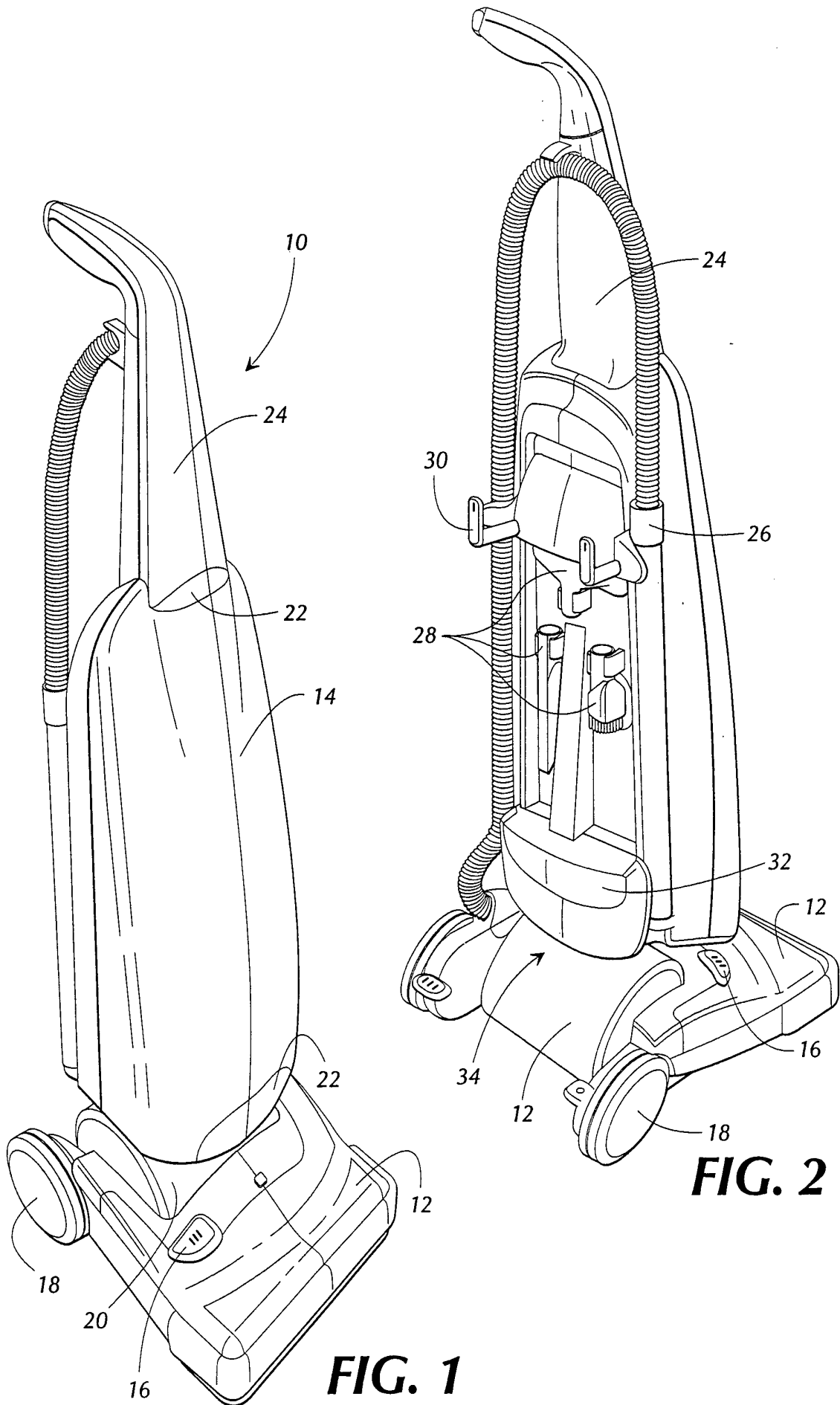

FIG. 1

FIG. 2

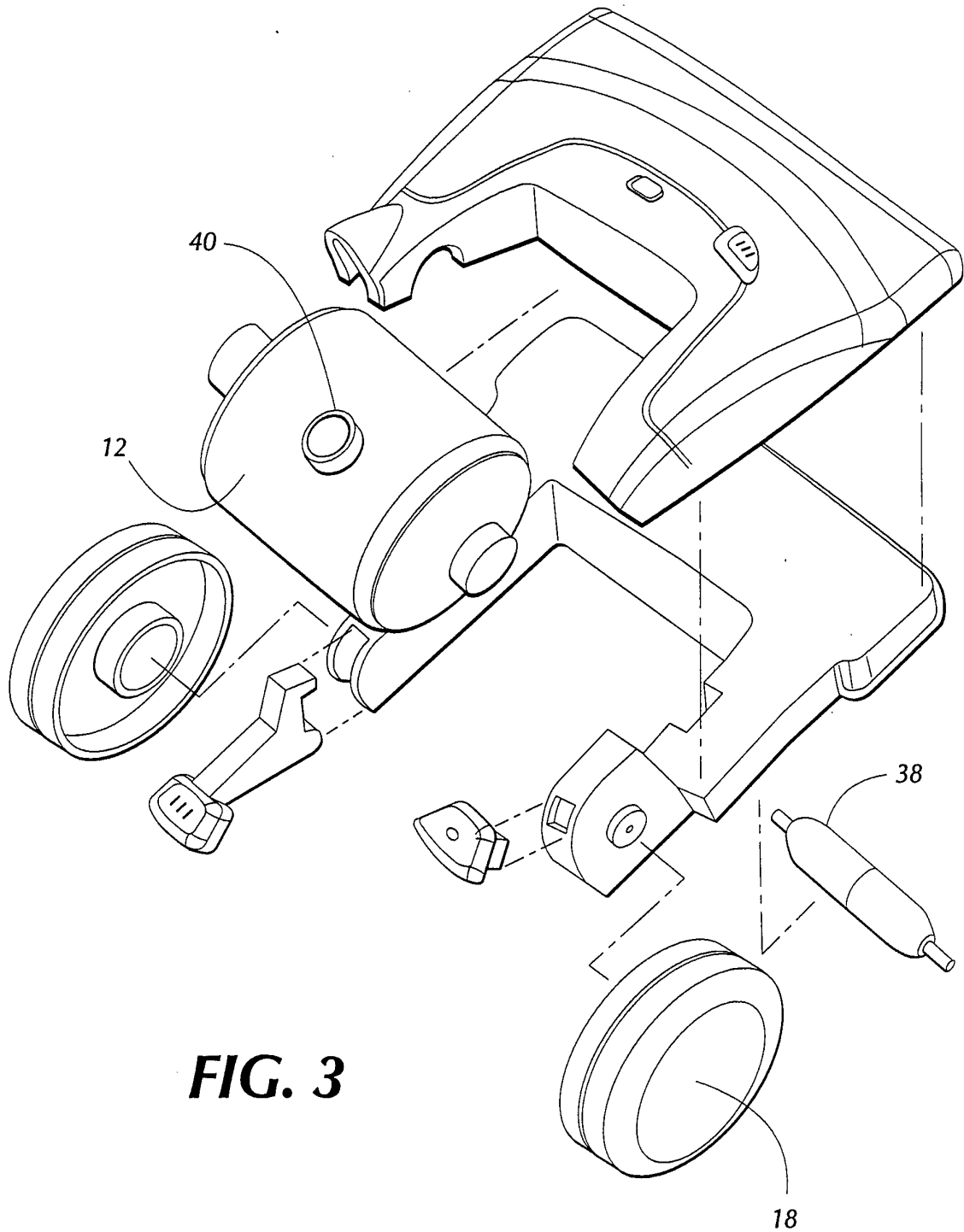

FIG. 3

- 3 / 5 -

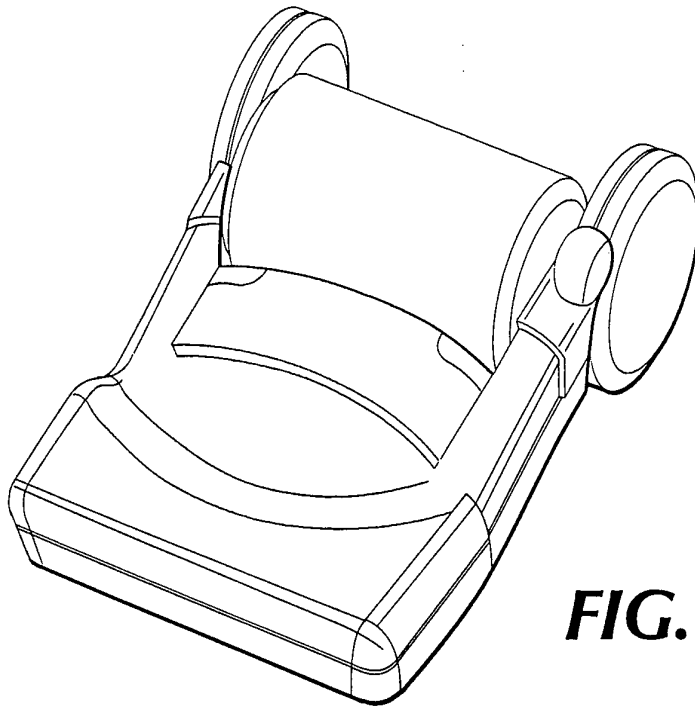

FIG. 4

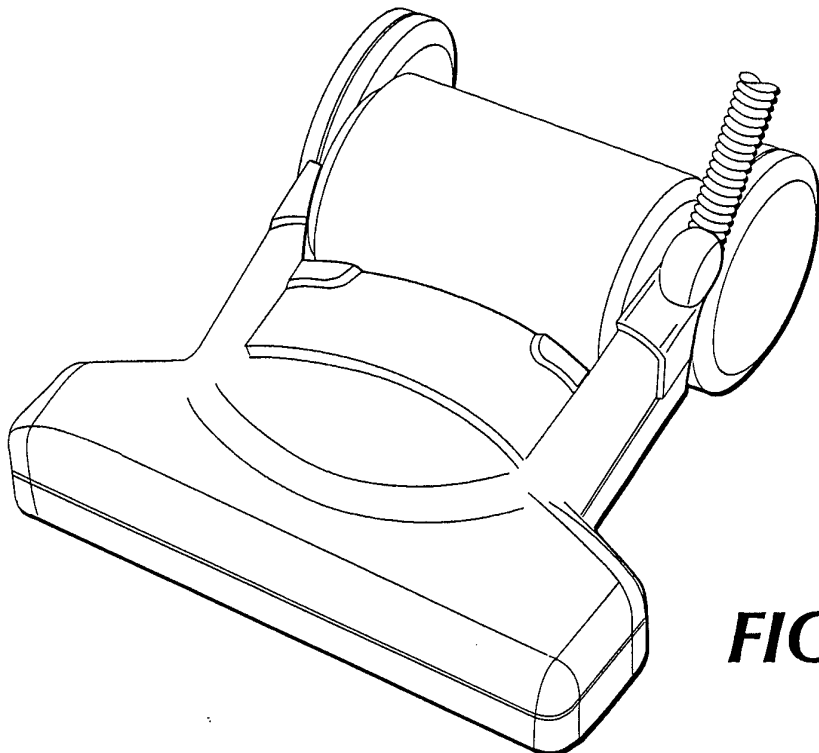

FIG. 5

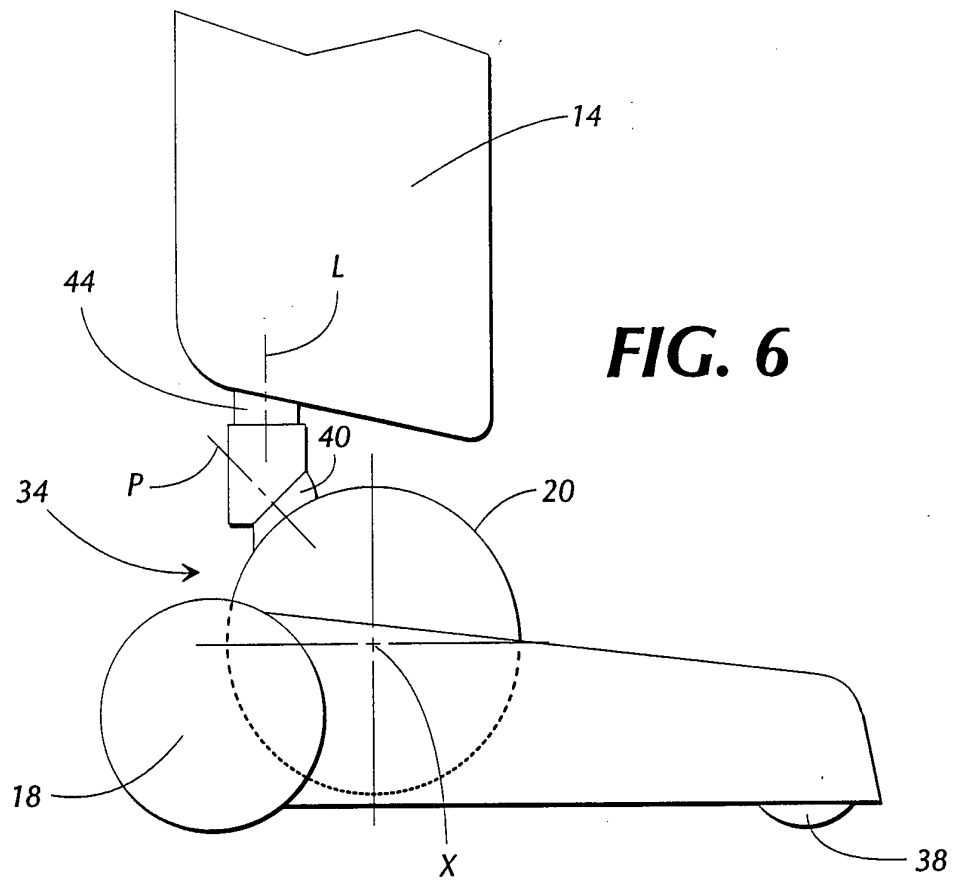

FIG. 6

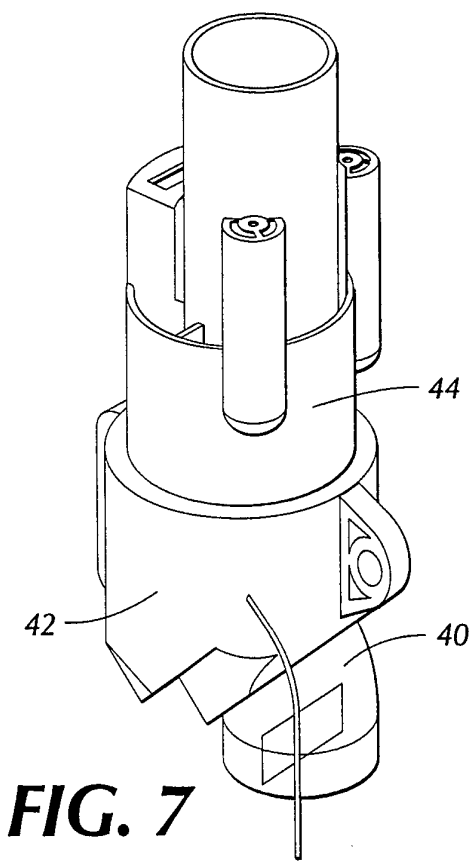

FIG. 7

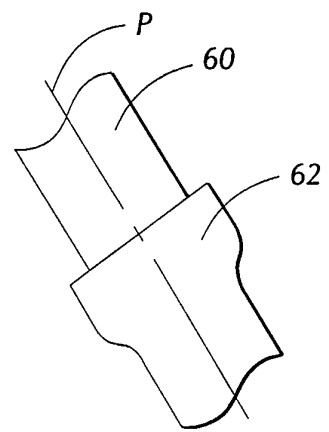

FIG. 10

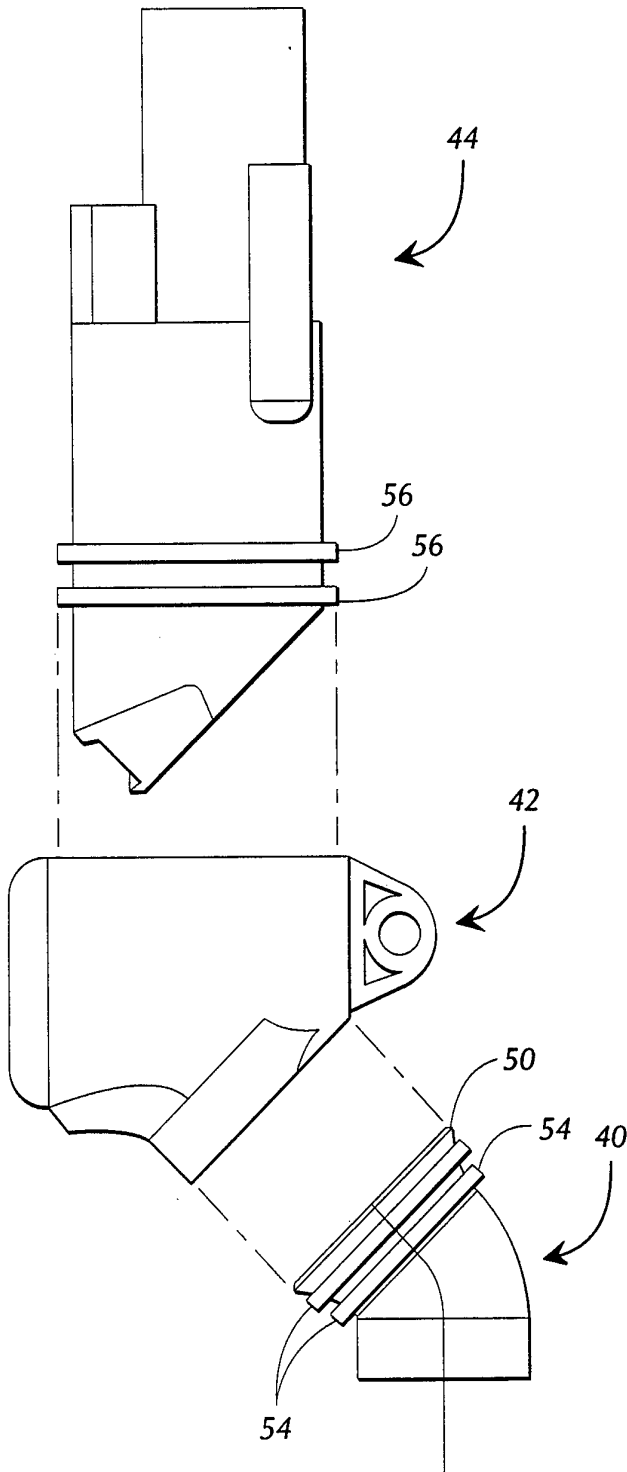

FIG. 8

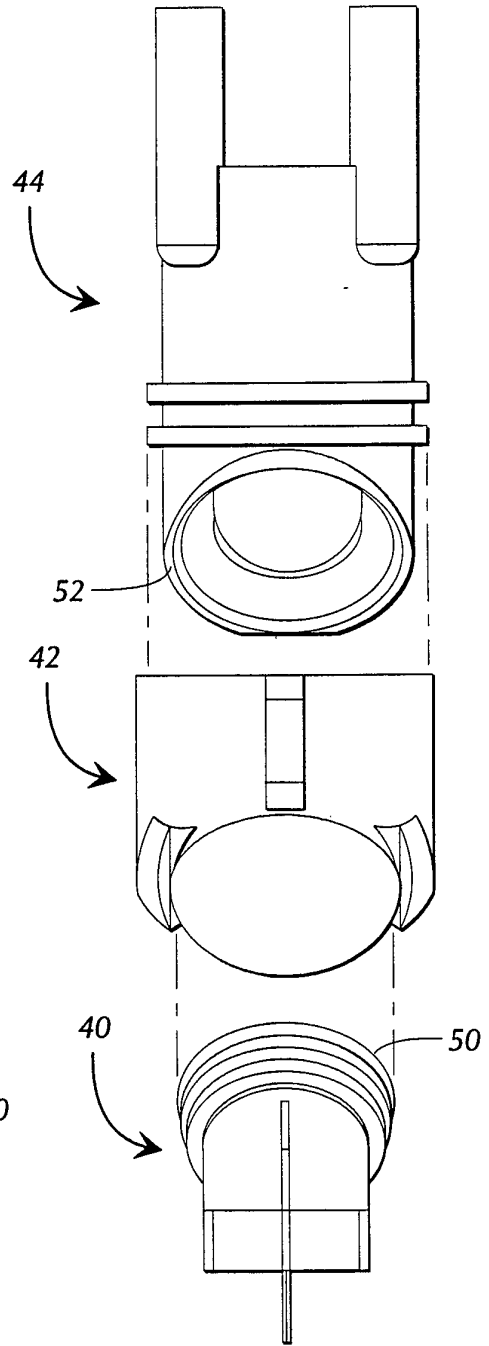

FIG. 9

INTERNATIONAL SEARCH REPORT

International application No.
PCT/US94/07148

A. CLASSIFICATION OF SUBJECT MATTER
 IPC(5) :A47L 9/32
 US CL : 15/411,323,339; 280/47.11
 According to International Patent Classification (IPC) or to both national classification and IPC

B. FIELDS SEARCHED
 Minimum documentation searched (classification system followed by classification symbols)
 U.S. : 15/411,323,339; 280/47.11

Documentation searched other than minimum documentation to the extent that such documents are included in the fields searched

Electronic data base consulted during the international search (name of data base and, where practicable, search terms used)

C. DOCUMENTS CONSIDERED TO BE RELEVANT

Category*	Citation of document, with indication, where appropriate, of the relevant passages	Relevant to claim No.
A	US,A, 1,086,367 (HOPE) 10 FEBRUARY 1914, FIG. 1.	1-7
A	US,A, 1,318,881 (KELLEY) 14 OCTOBER 1919, ENTIRE DOCUMENT	1-7
A	US,A, 1,355,553 (GOUGHNOUR) 12 OCTOBER 1920, ENTIRE DOCUMENT	1-7
A	US,A, 1,838,481 (GUDKA) 29 DECEMBER 1931, ENTIRE DOCUMENT	1-7
A	US,A, 1,940,609 (SIMPSON) 19 DECEMBER 1933, ENTIRE DOCUMENT	1-7
A	US,A, 2,038,697 (WINSLOW) 28 APRIL 1936, ENTIRE DOCUMENT	1-7

Further documents are listed in the continuation of Box C. See patent family annex.

* Special categories of cited documents:	"T"	later document published after the international filing date or priority date and not in conflict with the application but cited to understand the principle or theory underlying the invention
"A" document defining the general state of the art which is not considered to be of particular relevance	"X"	document of particular relevance; the claimed invention cannot be considered novel or cannot be considered to involve an inventive step when the document is taken alone
"E" earlier document published on or after the international filing date	"Y"	document of particular relevance; the claimed invention cannot be considered to involve an inventive step when the document is combined with one or more other such documents, such combination being obvious to a person skilled in the art
"L" document which may throw doubts on priority claim(s) or which is cited to establish the publication date of another citation or other special reason (as specified)	"g"	document member of the same patent family
"O" document referring to an oral disclosure, use, exhibition or other means		
"P" document published prior to the international filing date but later than the priority date claimed		

Date of the actual completion of the international search: 11 OCTOBER 1994
 Date of mailing of the international search report: 24 OCT 1994

Name and mailing address of the ISA/US Commissioner of Patents and Trademarks
 Box PCT
 Washington, D.C. 20231
 Facsimile No. (703) 305-3230

Authorized officer: CHRIS K. MOORE
 Telephone No. (703) 308-0324

Shella H. Vanev
 Paralegal Specialist
 Group 2400

INTERNATIONAL SEARCH REPORT

International application No.
PCT/US94/07148

C (Continuation). DOCUMENTS CONSIDERED TO BE RELEVANT

Category*	Citation of document, with indication, where appropriate, of the relevant passages	Relevant to claim No.
A	US, A, 2,974,347 (SEYFRIED) 14 MARCH 1961, ENTIRE DOCUMENT	1-7
A	US,A, 5,075,921 (GLEADALL) 31 DECEMBER 1991, ENTIRE DOCUMENT	1-7