

(19) World Intellectual Property Organization
International Bureau



(43) International Publication Date
22 April 2004 (22.04.2004)

PCT

(10) International Publication Number
WO 2004/033230 A2

- (51) International Patent Classification⁷: **B60B**
- (21) International Application Number: PCT/US2003/031325
- (22) International Filing Date: 2 October 2003 (02.10.2003)
- (25) Filing Language: English
- (26) Publication Language: English
- (30) Priority Data:

10/266,040	7 October 2002 (07.10.2002)	US
10/266,050	7 October 2002 (07.10.2002)	US
10/361,707	6 February 2003 (06.02.2003)	US
10/372,596	24 February 2003 (24.02.2003)	US
- (71) Applicants and
- (72) Inventors: **HODGES, Frank, J.** [US/US]; 20624 Mirkwood Run, Yorba Linda, CA 92887 (US). **ANCA, Sergiu** [US/US]; 12092 Le Ann Drive, Garden Grove, CA 92640 (US).
- (74) Agent: **DELANEY, Karoline, A.**; KNOBBE, MARTENS, OLSON AND BEAR, LLP, 2040 Main Street, Fourteenth Floor, Irvine, CA 92614 (US).
- (81) Designated States (*national*): AE, AG, AL, AM, AT (utility model), AT, AU, AZ, BA, BB, BG, BR, BY, BZ, CA, CH, CN, CO, CR, CU, CZ (utility model), CZ, DE (utility model), DE, DK (utility model), DK, DM, DZ, EC, EE (utility model), EE, EG, ES, FI (utility model), FI, GB, GD, GE, GH, GM, HR, HU, ID, IL, IN, IS, JP, KE, KG, KP, KR, KZ, LC, LK, LR, LS, LT, LU, LV, MA, MD, MG, MK, MN, MW, MX, MZ, NI, NO, NZ, OM, PG, PH, PL, PT, RO, RU, SC, SD, SE, SG, SK (utility model), SK, SL, SY, TJ, TM, TN, TR, TT, TZ, UA, UG, US, UZ, VC, VN, YU, ZA, ZM, ZW.
- (84) Designated States (*regional*): ARIPO patent (GH, GM, KE, LS, MW, MZ, SD, SL, SZ, TZ, UG, ZM, ZW), Eurasian patent (AM, AZ, BY, KG, KZ, MD, RU, TJ, TM), European patent (AT, BE, BG, CH, CY, CZ, DE, DK, EE,

[Continued on next page]

(54) Title: WHEEL WITH EXTENDED OUTER FLANGE AND CORRESPONDING TIRE

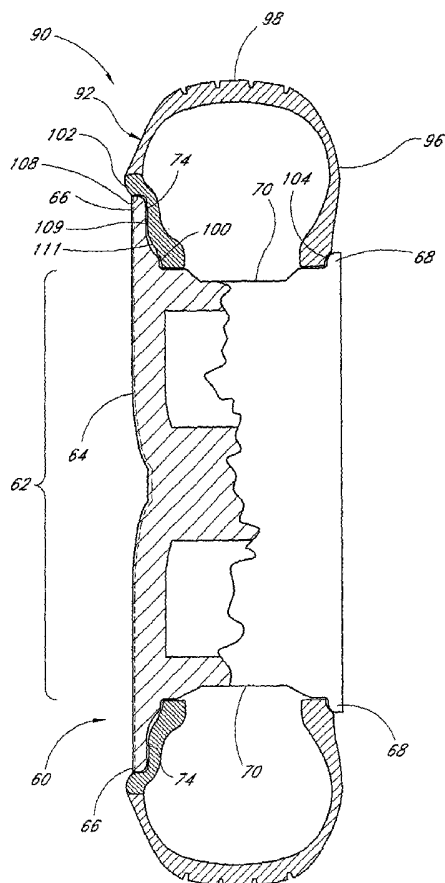

(57) Abstract: The present invention provides an improved wheel and tire for simulating the appearance of a larger-diameter wheel mounted within a low-profile tire. The wheel has an inboard side and an outboard side. The outboard side preferably includes a wide outer flange which extends around the outer circumference of the wheel. The outer flange is preferably integral with the outboard side of the wheel. The outer flange may also be detachable from the remainder of the wheel. The inboard side may also include a wide inboard flange which is preferably detachable. The flange preferably covers a substantial portion of the wall of the outer tire within which the wheel is mounted. A design, preferably comprised of, for example, a plurality of protrusions, indentations, and slits, extends across at least a portion of the outboard face of the wheel, including the outboard face of the extended outer flange.[0086] The improved tire of the present invention is intended to be mounted on the improved wheel of the present invention with an extended outer flange. The tire comprises an outboard tire wall, an inboard tire wall, and a tread therebetween. The outboard tire wall preferably includes a laterally extending wheel protector, a ledge, and a flange seat. The flange seat is preferably contoured to match the inner face of the outer flange of the wheel and is preferably more rigid than the remainder of the tire to prevent the tire from deflecting into the outer flange of the wheel under the load of a vehicle.

WO 2004/033230 A2



ES, FI, FR, GB, GR, HU, IE, IT, LU, MC, NL, PT, RO,
SE, SI, SK, TR), OAPI patent (BF, BJ, CF, CG, CI, CM,
GA, GN, GQ, GW, ML, MR, NE, SN, TD, TG).

Published:

— *without international search report and to be republished
upon receipt of that report*

Declaration under Rule 4.17:

— *of inventorship (Rule 4.17(iv)) for US only*

For two-letter codes and other abbreviations, refer to the "Guidance Notes on Codes and Abbreviations" appearing at the beginning of each regular issue of the PCT Gazette.

WHEEL WITH EXTENDED OUTER FLANGE AND CORRESPONDING TIRE**Related Application**

[0001] This application is a continuation-in-part of U.S. Patent Application Serial No. 10/266,040, filed on October 7, 2002.

Background of the Invention**Field of the Invention**

[0002] This invention relates generally to tires and wheels for vehicles and in particular to tires and wheels for creating the appearance of low-profile tires mounted on large-diameter wheels.

Description of the Related Art

[0003] In recent years, consumer demand for large-diameter vehicle wheels mounted within low-profile tires has increased dramatically. Such wheels and tires create a stylish look for the vehicle on which they are used, but they cost much more than standard-sized wheels and tires. As a consequence, large-diameter wheels and low profile tires are desired by many consumers, but are beyond the financial reach of a large segment of the market. Moreover, most companies that make wheels are set up for mass production of wheels of certain standard sizes, and have often lagged behind consumer demand in developing or re-tooling expensive equipment, including molds and casting machinery, to produce the largest wheels desired by consumers.

[0004] In addition, as wheels become larger and the corresponding tires become smaller, the ride performance of the wheel-tire combination often suffers. For example, a smaller tire surrounding a larger wheel provides less air volume to support the vehicle. The proper amount of air volume allows the vehicle to absorb substantial vibration and other vertical and/or horizontal motion in the wheels. When the air volume is reduced, the vehicle may not ride as smoothly and the weigh-load rating may be more limited. By limiting the weigh-load rating, the market for certain types of vehicles (such as trucks or SUVs) may be significantly decreased. Thus, it would be advantageous to provide the appearance of thinner tire and larger wheel while providing a smoother ride, higher weight-load rating, and more tire between the wheel and the road.

[0005] Some consumers who want the look of large-diameter wheels, but who cannot afford them or are concerned with diminished ride performance, may be willing to pay an intermediate cost to make standard-sized wheels and tires take on the appearance of the more expensive (and possibly unavailable) products. Detachable wheel extensions, such as the one shown in U.S. Patent Publication No. US 2002/0079735 A1, have been used to attempt to simulate the appearance of larger wheels mounted within low-profile tires. However, such extensions mask a portion of the front face of the wheel and do not provide a surface integral with the design on the face of the wheel. Thus, the attempted simulation does not have a realistic appearance.

[0006] In particular, some wheel extensions of the prior art have an inner ring that is removably secured within an inside edge of the outer lip of the existing wheel using a compression fit (as with a standard hub cap). A wide outer flange is attached to the inner ring and extends radially outwardly across a portion of the outside tire wall. The wheel extensions are intended to be used with many different types of wheels having a variety of surface designs on their front faces. The outward surfaces of the inner ring and outer flange generally have a smooth, generic appearance to attempt to aesthetically interface with all of these different designs. Although outer flanges of the prior art may include a narrow, upturned lip formed along the outer diameter of the flange and/or an undulated outward surface (e.g., a smooth stair-step pattern of concentric rings), the flanges do not include protrusions, indentations, or slits on their surfaces as are commonly found on the central portion of the front face of many wheels.

[0007] The inner ring for securing the wheel extension to the wheel is generally at least about 1/2 inch thick around its circumference, which covers up a significant portion of the underlying wheel face. When mounted on a wheel with a 17-inch diameter, a 1/2-inch thick ring makes the wheel appear to be only 16-inches in diameter. This results in a reduction of the visible surface area of the wheel by well over 10 percent. In addition, the smooth outward surfaces of the inner ring and outer flange generally do not blend in well with the existing design of the wheel. Indeed, the wheel extensions of the prior art are usually easily detectable by even a casual observer, and merely give the appearance of an over-extended add-on lip covering a portion of the outer tire wall. Thus, the attempted

simulation is not only ineffective, it actually creates the opposite effect. Rather than simulating a larger wheel mounted within a low profile tire, the wheel extension gives the appearance of a smaller wheel mounted on a standard tire.

Summary of the Invention

[0008] The present invention provides an improved wheel and tire for simulating the appearance of a larger-diameter wheel mounted within a low-profile tire. The wheel has an inboard side and an outboard side. The outboard side includes a wide outer flange which extends around the outer circumference of the wheel. The outer flange is preferably integral with the outboard face of the wheel and covers a substantial portion of the outer wall of the tire within which the wheel is mounted. The outer flange of the wheel may also be detachable from the remainder of the wheel. The inboard side may also include a wide inboard flange that is preferably detachable. A design, preferably comprised of, for example, a plurality of protrusions, indentations, and slits, extends across at least a portion of the outboard face of the wheel, including the outboard face of the extended outer flange.

[0009] The improved tire of the present invention is intended to be mounted on the improved wheel of the present invention with at least one extended outer flange. The tire comprises an outboard tire wall, an inboard tire wall, and a tread therebetween. The outboard tire wall preferably includes a laterally extending wheel protector, a ledge, and a flange seat. The inboard wall may also include a wheel protector, a ledge, and a flange seat. The flange seat is preferably contoured to match the corresponding faces of the inner or outer flanges of the wheel, and the flange seat may be more rigid than the remainder of the tire to prevent the tire from deflecting into the outer flange of the wheel under the load of a vehicle.

[0010] The wheel of the present invention may be mounted within a standard tire of the prior art or may be mounted within the tire of the present invention to produce a highly effective simulation of a larger-diameter wheel mounted with a low-profile tire, without sacrificing wheel and/or tire ride performance.

Brief Description of the Drawings

[0011] **FIGURE 1** is an outboard perspective view of a wheel as in the prior art.

[0012] **FIGURE 2** is a side view of the wheel of **FIGURE 1**.

[0013] **FIGURE 3** is an outboard front view of a tire to be mounted on the wheel of **FIGURE 1** as in the prior art.

[0014] **FIGURE 4** is an outboard front view of the wheel of **FIGURE 1** with the tire of **FIGURE 3** mounted thereon.

[0015] **FIGURE 5** is a side view of the wheel and tire of **FIGURE 4**.

[0016] **FIGURE 6** is an outboard perspective view of an embodiment of a wheel of the present invention.

[0017] **FIGURE 7** is a side view of the wheel of **FIGURE 6**.

[0018] **FIGURE 7A** is a side view of another embodiment of a wheel of the present invention.

[0019] **FIGURE 7B** is a side view of another embodiment of a wheel of the present invention.

[0020] **FIGURE 7C** is a side view of another embodiment of a wheel of the present invention.

[0021] **FIGURE 7D** is a side view of another embodiment of a wheel of the present invention.

[0022] **FIGURE 8** is an outboard front view of the wheel of **FIGURE 6** with the tire of **FIGURE 3** mounted thereon.

[0023] **FIGURE 8A** is an outboard front view of the wheel of **FIGURE 7A** or **FIGURE 7C** with the tire of **FIGURE 3** mounted thereon.

[0024] **FIGURE 8B** is an outboard front view of the wheel of **FIGURE 7B** with the tire of **FIGURE 3** mounted thereon.

[0025] **FIGURE 9** is a side view of the wheel and tire of **FIGURE 8**.

[0026] **FIGURE 10** is an outboard front view of an embodiment of a tire of the present invention.

[0027] **FIGURE 11** is a side view of a wheel of the present invention with the tire of **FIGURE 10** mounted thereon.

[0028] **FIGURE 11A** is a side view of a wheel of the present invention with another embodiment of the tire of the present invention mounted thereon.

[0029] **FIGURE 11B** is a side view of another embodiment of a wheel of the present invention with the tire of **FIGURE 11A** mounted thereon.

[0030] **FIGURE 12** is a side view of another embodiment of a wheel of the present invention with the tire of **FIGURE 10** mounted thereon.

[0031] **FIGURE 13** is a side view of another embodiment of a wheel of the present invention with the tire of **FIGURE 10** mounted thereon.

[0032] In **FIGURES 2, 5, 7, 9, and 11**, a portion of the wheels is shown cut away to illustrate the interior space.

Detailed Description of the Preferred Embodiment

[0033] When mounted on a vehicle, a wheel has an "inboard" side that faces the interior of the vehicle and an "outboard" side that faces away from the vehicle. **FIGURE 1** shows an outboard perspective view of a wheel **20** as in the prior art. The wheel **20** has a central hub **22** with an outboard face **24**. The wheel **20** also has a sidewall **26** that extends horizontally away (i.e., in the outboard direction) from the central hub **22**, and an outboard lip **28** that extends radially outwardly from the outer edge of the sidewall **26**. As used herein, the term "radially outwardly" refers to substantially circular or cylindrical surfaces that extend from an inner point, line, or circle to an outer circle.

[0034] Referring to **FIGURE 2**, on the inboard side of the wheel **20** is an inboard lip **30** that is similar in shape and size to the outboard lip **28**. In a typical wheel of the prior art, each lip **28, 30** is about 3/4 inch long from the base of the lip to the peak of the lip, and about 1/4 inch in thickness from the outboard side of the lip to the inboard side of the lip.

[0035] The portion of the wheel **20** extending between the inboard lip **30** and the outboard lip **28** is known as the wheel barrel **32**. The barrel **32** is substantially cylindrical in shape and its central axis lies on the center of the face **24** of the wheel **20**. In a typical 17-inch wheel, the distance along the wall **38** of the barrel **32** between the inboard lip **30** and the outboard lip **28** is about 8 inches. The barrel **32** must be sufficiently rigid to resist the substantial forces that act upon the wheel **20**, especially during extreme acceleration, braking, and turning. As a result, the majority of the mass of the wheel **20** is generally located in the barrel **32**, and the majority of the cost of the alloy metal used to make the wheel is spent on the material for the barrel **32**.

[0036] There is a significant difference in barrel 32 masses among wheels of different sizes. An approximation for the volume of the alloy metal required to make the barrel 32 is calculated as follows:

$$0.25 \pi t (d_{out}^2 - d_{in}^2)$$

[0037] where t is the barrel depth or distance between the inboard and outboard lips 30, 28; d_{in} is the inner diameter of the barrel 32; and d_{out} is the outer diameter of the barrel 32. The foregoing formula approximates the volume of the barrel 32 by presuming that the wall of the barrel 32 has a uniform diameter across its entire surface, even though it varies somewhat (due primarily to the sloping portions 34), but the calculation is sufficiently close for purposes of this description.

[0038] The thickness of the wall of the barrel 32 is typically about 5/16 inch. As an example, a 17-inch wheel has an inner barrel diameter (d_{in}) of about 17 inches, an outer barrel diameter (d_{out}) of about 17 5/8 inches (i.e., the inner diameter plus the wall thickness on both sides), and a barrel depth (t) of about 8 inches. Using the foregoing equation, the resulting volume of the alloy metal for a 17-inch wheel is calculated to be about 136 cubic inches. In contrast, a 22-inch wheel has an inner barrel diameter of about 22 inches, an outer barrel diameter of about 22 5/8 inches, and a barrel depth of about 10 inches. The resulting volume of the alloy metal is therefore about 220 cubic inches. Thus, a 22-inch wheel requires over 60% more alloy metal for the wall of the wheel barrel 32 than a 17-inch wheel, even though the inner barrel diameter is less than about 30% larger in a 22-inch wheel than a 17-inch wheel. This difference in material requirements is the primary reason why large-diameter wheels are much more expensive to manufacture than standard-sized wheels.

[0039] Referring to FIGURES 3-5, the tire 40 includes an outboard tire wall 42, an inboard tire wall 44, a tread 46, an outboard bead 48, an inboard bead 50, and a wheel void 52. The tire beads 48, 50 are essentially indented rings formed on the inner radial edges of the respective inboard and outboard tire walls 42, 44. The wheel 20 is mounted within the wheel void 52 of the tire 40.

[0040] During the tire mounting process, the outboard bead 48 of the tire 40 is forced behind the outboard lip 28 of the wheel 20, and the inboard bead 50 is forced behind

the inboard lip 30. The width of the beads 48, 50 is intended to generally correspond to the height of the lips 28, 30. When a mounted tire is filled with air, the interior air pressure forces the beads 48, 50 firmly against the interior sides of the lips 28, 30, forming an air-tight seal. Because the lips 28, 30 and beads 48, 50 have generally corresponding sizes, the tire walls 42, 44 usually do not, under normal conditions and stationary loads, need to contort or stretch to pass around the lips 28, 30.

[0041] **FIGURE 6** is an outboard perspective view of an embodiment of a wheel 60 of the present invention. The wheel 60 has an outboard face 64 and an inboard face (not shown). The outboard face 64 is comprised of two concentric regions: a central hub 62 and an extended outer flange 66. As used herein, terms relating to circles and cylinders, such as "circular," "cylindrical," "diameter," "radius," and "concentric," are not intended to be limited to perfectly round structures. Rather, generally circular shapes, including those with large radial protrusions or indentations are encompassed by these terms.

[0042] The central hub 62 and the outer flange 66 may be integral with each other. The structural integrity may reduce the risk that the component parts become damaged and separated, and it may provide a greater degree of continuity in appearance between the structures. The central hub 62 and the outer flange 66 are still considered to be integral with each other if additional structures (such as, for example, a lug nut cover) are attached to all or a portion of the central hub 62.

[0043] The region between the outboard face 64 and the inboard face is the wheel barrel 70. The wheel barrel 70 is approximately cylindrical in shape and its central axis lies approximately on the center of the face 64 of the wheel 60. An inboard lip 68 extends radially outwardly along the outer edge of the inboard face.

[0044] The central hub 62 extends radially from the center of the outboard face 64 to approximately the same outer diameter as the wheel barrel 70 (which is attached to the inboard side of the outboard face 64). The outer flange 66, in turn, extends from the outer diameter of the central hub 62 to the full outer diameter of the wheel face 64. The outer flange 66 has an outboard face 72 and an inboard face 74 (see **FIGURE 7**). In the embodiment shown in **FIGURE 6**, the boundary between the central hub 62 and outer flange 66 is essentially seamless. The seamless boundary is preferred because it enhances the

desired simulation of a larger-diameter wheel. However, wheels with readily discernible boundaries between the central hub 62 and outer flange 66 may still provide the desired appearance and are encompassed by the present invention.

[0045] In the illustrated example, the diameter of the central hub 62 is approximately 17 inches, and the radial width across the flange face 72 is approximately 2-1/2 inches. Thus, the diameter of the outboard face 64 of the wheel 60 is approximately 22 inches. Numerous other possible size combinations will be apparent to those of skill in the art after reading this disclosure. For example, central hubs 62 having diameters between 13 inches and 22 inches could be combined with outer flanges 66 with widths of 1 inch, 1 1/2 inch, 2 inches, 2 1/2 inches, 3 inches, 3 1/2 inches, or 4 inches to produce overall wheel faces 64 of between 15 inches and 30 inches. Many other sizes within and beyond these ranges and examples are encompassed by the present invention.

[0046] As shown in FIGURE 6, the wheel 60 includes an integral aesthetic design on its outboard face 62. The design preferably extends from the central hub 62 into and across at least a portion of the outer flange 66. The design on the front face 72 of the outer flange 66 preferably includes a pattern of surface variations comprising a plurality of at least one of either indentations 76, protrusions 78, or slits 80 that are aesthetically consistent with and blend into the design of the central hub 62. As used herein, the term "slits" encompasses grooves formed on a surface whether or not such grooves pass through the surface. In the illustrated embodiment, the integral design creates the appearance that the spokes formed on the central hub 62 extend into the outer flange 66, making it more difficult to perceive upon casual inspection where the central hub 62 ends and the outer flange 66 begins. Indeed, the consistency and blending of the designs on the central hub 62 and outer flange 66 make it unlikely that the casual observer of a mounted wheel 60 would notice that the outer flange 66 extends beyond the wheel barrel 70.

[0047] In the illustrated example, the outer flange 66 has an upper portion 67 and a lower portion 69. The thickness of the upper portion 67 of the outer flange 66 is about 1/4 inch, although the indentations and protrusions on the outboard surface of the outer flange 66 may produce variations in the thickness of the outer flange 66 in certain regions across its face. The thickness of the upper portion 67 of the outer flange 66 is preferably

between about 1/8 inch to 1/4 inch, and the outboard and inboard surfaces of the upper portion 67 are preferably generally parallel. In the illustrated embodiment, the lower portion 69 of the outer flange 66 is thicker than the upper portion 67. The inboard face of the lower portion 69 preferably has a curved upper edge and a straight lower edge. In the example shown, the thickness of the lower portion 69 ranges from about 1/4 inch along its upper edge to about 1/2 inch along its lower edge. The thickness of the outer flange 66 for a given wheel is determined by a variety of factors relating to aesthetics and structural integrity. Many other possible shapes and thicknesses for the outer flange 66 will be apparent to those of skill in the art after reading this disclosure and are encompassed by the present invention.

[0048] As shown in **FIGURE 7**, the radial extension of the inboard lip 68 is preferably less than the radial extension of the outer flange 66. In the illustrated embodiment, the height of the inboard lip 68 is about 3/4 inch long from its peak to its base (at the outer radius on the inboard side of the wheel barrel 70), and about 1/4 inch in thickness from its outboard side to its inboard side. Thus, the inboard lip 68 is preferably comparable in size to the inboard and outboard lips 30, 28 of typical prior art wheels. The height of the inboard lip is preferably between about 1/2 inch and 3/4 inch. The inboard lip 68 is preferably smaller than the outer flange 66 to facilitate mounting a tire on the wheel 60 by permitting the leading edge of the tire to be slid over the smaller inboard side of the wheel 60 and then merely abutted against the interior side of the extended flange 66. It would be more difficult to slide the leading edge of the tire over the extended outer flange 66 on the outboard side of the wheel 60. Moreover, the smaller inboard lip 68 requires less alloy metal material than would an inboard lip comparable in size to the outer flange 66. The inboard lip 68 may also be comparable in size and/or shape with the outer flange 66 so as to produce a more balanced wheel 60.

[0049] Additional embodiments of the wheel of the present invention are shown in **FIGURES 7A-7D**. In the embodiment of **FIGURE 7A**, the outboard face 64 of the wheel 60 is removably attached to the remainder of the wheel 60. The wheel 60 preferably includes an outboard lip 71 that is comparable in size and shape to the inboard lip 68. The removable outboard face 64 includes an outer flange 66 that extends radially beyond the outer

diameter of the outboard lip 71. The inboard face 74 of the outer flange 66 preferably includes a notch 73 that extends in the inboard direction.

[0050] The notch 73 preferably abuts against the outboard lip 71, and helps to properly align the outboard face 64 with the outboard lip 71 during installation (e.g., as a stock component or as an after-market product). The notch 73 also helps to bear the weight load of the vehicle between the tire and the wheel barrel 70, especially upon decompression of the tire on which the wheel 60 is mounted. Without a notch 73 or an equivalent structure, the weight of the vehicle would be borne substantially by the bolts (described below) or other means which connect the outboard face 64 to the remainder of the wheel 60.

[0051] The outboard face 64 of the embodiment shown in FIGURE 7A, like the outboard face 64 shown in FIGURE 6, preferably includes an integral aesthetic design that extends into and across at least a portion of the outer flange 66. The design on the outboard face 64 of the outer flange 66 preferably includes a pattern of surface variations comprising a plurality of at least one of either indentations, protrusions, or slits that are aesthetically consistent with and blend into the design on the central hub 62 of the outboard face 64.

[0052] The outboard face 64 is preferably attached to the remainder of the wheel 60 by bolts 75 passing through the outboard face and into the central and/or peripheral portions of the central hub 64. Those of skill in the art will appreciate after reading this disclosure that alternative or additional means may also be used to attach the outboard face 64 to the central hub 62 and are encompassed by the present invention.

[0053] For example, the outboard face 64 could also be attached to the remainder of the wheel 60 using the lug studs and lug nuts (not shown) that attach the wheel 60 to the vehicle. In such an arrangement, the lug studs would preferably be longer than standard studs so that they would extend from the vehicle, through the central hub 62 of the wheel 60, and through lug holes in the central portion of the outboard face 64. The lug nuts would then be passed over the lug studs until the lug nuts abut securely against the outboard side of the outboard face 64. Alternatively, a first set of lug nuts may be used to secure the underlying wheel 60 to the vehicle in the conventional manner, and then the outboard face 64 may be mounted against the wheel 60 with the extended portion of the lug bolts passing through corresponding holes in the central part of the outboard face 64. A second set of lug nuts may

then be used to secure the outboard face 64 to the wheel 60 by passing such nuts over the extended portions of the lug bolts and against the outboard face 64. The outboard face 64 may also be secured to the wheel 60 by passing screws 79 through the central portion of the outboard face 64 and into the wheel 60 between the lug nuts (see FIGURE 8A). The means for connecting the outboard face 64 to the wheel 60, whether in the form of bolts, lug nuts, screws, or some other equivalent connector, may be covered by additional structures such as plates or caps to achieve a desired aesthetic or functional effect.

[0054] The embodiment of FIGURE 7A generally provides the following advantages (depending upon the particular way it is implemented): (1) allowing a user to remove the outboard face 64 and replace it with an alternative outboard face with a different design (or a standard hubcap); (2) during tire installation, maintenance, and/or replacement, the extended flange 66 on the outboard face 64 is not an obstruction because the outboard face 64 can be quickly and easily removed; (3) if the outboard face 64 is damaged, it may generally be replaced at a lower cost than replacing the entire wheel 60; and (4) the vehicle on which the wheel 60 is mounted may generally be used even when the outboard face 64 is removed. These advantages are not necessarily achieved in all embodiments of FIGURE 7A or in other embodiments of the present invention.

[0055] In the embodiment of FIGURE 7B, the outer flange 66 is removably attached to the remainder of the wheel 60. The outer flange 66 in this embodiment is preferably a ring with an inner diameter smaller than the outer diameter of the outboard lip 71 and with an outer diameter larger than the outer diameter of the inboard lip 71. Accordingly, the outer flange, when aligned with the periphery of the central hub 64, preferably overlaps a portion of the central hub 62 and extends radially outwardly beyond the outboard lip 71.

[0056] Bolts 75 are preferably passed through the outer flange 66 in the region of overlap with the central hub 64 to thereby removably secure the outer flange 66 thereto. Those of skill in the art will appreciate after reading this disclosure that other means for attaching the outer flange 66 to the central hub 62 may also be used and are encompassed by the present invention.

[0057] As in the embodiments of FIGURES 7 and 7A, the outboard face of the central hub 64 of FIGURE 7B includes an aesthetic design, and the outboard face 72 of the

outer flange 66 also includes an aesthetic design. Preferably, the respective designs of the central hub 62 and outer flange 66 are consistent and blend with each other to create the impression that the outer flange 66 is a unitary part of the wheel 60. The embodiment of **FIGURE 7B** preferably provides each of the advantages described in connection with the embodiment of **FIGURE 7A**. The foregoing advantages may be more pronounced in the embodiment of **FIGURE 7B** because it is generally more easily detachable and less expensive to manufacture.

[0058] The embodiment of **FIGURE 7C** is very similar to the embodiment of **FIGURE 7A**, but the outboard face 64 includes the outboard lip 71. The bolts 75 are preferably longer in the illustrated embodiment (as compared with the embodiment of **FIGURE 7A**) so as to extend from the outboard face 64 a sufficient distance into the outboard portion of the wheel barrel 70. By combining the outboard face 64 and the outboard lip 71 into a unitary structure, it is generally possible to more easily install or remove a tire on the wheel, especially when tire-installation equipment is not readily available. The tire bead would not need to be bent or stretched around the outboard lip 71 of the wheel 60 because the outboard lip 71 may be removed entirely before sliding the tire on the wheel 60. Such an arrangement makes it more convenient to replace a punctured or blown-out tire on the road. Indeed, it would not even be necessary for vehicles to include a heavy spare tire-wheel combination. Instead, vehicles equipped with the embodiment of **FIGURE 7C** (and other embodiments shown herein) could merely carry an extra tire without the extra wheel. Many vehicle emergency kits come standard with small portable compressors for filling up tires which could be used to fully inflate a spare tire mounted on a wheel with a detachable bead.

[0059] The embodiment of **FIGURE 7C** also preferably includes an aesthetic design on the outboard face of the central hub 64 and on the outer flange 66. As with the other embodiments described herein, the respective designs on the central hub 64 and outer flange 66 are preferably consistent with and blend into each other.

[0060] In the embodiment of **FIGURE 7D**, the inboard side of the wheel includes a detachable inboard flange 77. The inboard flange 77 is preferably connected to the inboard side of the wheel using bolts 79. As previously explained, other attachments means may also

be used. The inboard flange 77 makes the wheel 60 more balanced by including structures of approximately the same weight and radial position on the opposite side of the wheel 60 from the outboard flange 66. The precise balancing of wheels and tires is often a challenge for those designing and maintaining vehicles because imbalances may potentially cause road noise or misalignment problems. Moreover, when a tire is punctured during travel or removed for maintenance or replacement, the vehicle may tip in the direction of the deflated tire and rest upon the outermost radial portions of the wheel on which the tire was mounted. In the embodiment of **FIGURE 7D**, the load carried by the outboard flange 66 is effectively reduced by half because it is shared by the inboard flange 77.

[0061] The width of the inboard flange 77 (i.e., the difference between its outer diameter and its inner diameter) in the illustrated embodiment is approximately 2 1/2 inches. The width of the inboard flange 77 may be varied depending upon the intended usage of the wheel 60, and such widths may include 1 inch, 1 1/2 inches, 2 inches, 2 1/2 inches, 3 inches, 3 1/2 inches, or 4 inches. Many other widths within and beyond these ranges and examples are encompassed by the present invention.

[0062] The inboard flange is preferably detachable, especially when used with a wheel having a unitary outer flange 66 and central hub 62 (as shown in **FIGURE 7D**) to facilitate removal, when necessary, of the tire from the wheel 60. The inboard flange 77 may also be used on the embodiments shown in **FIGURES 7A** and **7B**. The inboard flange may also be integral with the inboard lip 28, especially if used on the embodiments of **FIGURES 7A** and **7B**, wherein the tire may be removed by passing it over the outboard side of the wheel 60. The inboard flange 77 may also be integral with a removable inboard wheel face plate which may include the inboard lip (e.g., a mirror image of the embodiments shown in **FIGURE 7A** and **7C**).

[0063] The inboard flange 77 preferably does not include a design on its face because it is not normally open to view when mounted on the vehicle, and a design would add unnecessary cost to the product. The inboard flange 77 could alternatively be produced with a design on its face to produce a more precise balance between the inboard and outboard sides of the wheel or for other considerations.

[0064] The various embodiments of the wheel **60** may be mounted within a typical prior art tire such as the tire **40** illustrated in **FIGURE 3**. During the tire mounting process, the outboard bead **48** of the tire **40** is positioned behind the outer flange **66**, and the inboard bead **50** is positioned behind the inboard lip **68**. When the mounted tire is filled with air, the interior air pressure forces the beads **48**, **50** firmly against the interior sides of the outer flange **66** and the inboard lip **68**.

[0065] **FIGURE 8** is an outboard front view of the wheel **60** with a typical prior art tire **40** mounted thereon. Although the diameters of the barrels **32**, **70** of the wheels **20**, **60** shown in **FIGURES 4** and **8** are the same, and the tires **40** on which the wheels are mounted are the same, the mounted wheels **20**, **60** have a remarkably different outward appearance. The wheel **60** of **FIGURE 8** gives the appearance of a significantly larger diameter wheel mounted on a low-profile tire. Upon casual inspection, it is unlikely that an observer would perceive that the barrel **70** of the wheel **60** actually has a much smaller diameter and that the outer flange **66** extends across a substantial portion of the outboard tire wall **42**. Indeed, the diameter of the wheel **60** may even be made to appear to be larger than any wheel readily available to consumers in the mass-production wheel market.

[0066] The front view of the additional embodiments of **FIGURES 7A** and **7C** are shown in **FIGURE 8A**, and the front view of the additional embodiment of **FIGURE 7B** is shown in **FIGURE 8B**. If means are used to cover the bolts and/or screws (or equivalent connectors), then these embodiments would look even more like the embodiment shown in **FIGURE 8**.

[0067] Referring to **FIGURE 9**, the interface between the inboard lip **68** and the inboard tire wall **44** is similar to that of standard wheels and tires of the prior art. The inboard bead **50** is shaped to correspond to the size and shape of the inboard lip **68**. The inboard tire wall **44** usually will not bend or contort to stretch around the inboard lip **68** under stationary loads and normal operating conditions.

[0068] The outboard bead **48** of the tire **40** interfaces with the lower portion **69** of the outer flange **66**. The outboard tire wall **42** is pushed in the inboard direction by the outer flange **66**, causing the tire wall **42** to bend inwardly around the outer flange **66**. Thus, the tire **40**, when mounted on the wheel **60** with the outer flange **66**, has a somewhat concave

radially inward outboard surface, whereas the tire 40, when mounted on the wheel 20 with a typical outboard lip 28, has a more convex radially inward outboard surface (see FIGURE 5) when pressurized under a standard vehicle load.

[0069] The use of a standard tire 40 on the wheel 60 is feasible, but has potential disadvantages. First, as previously explained, the inner radial portion of the outboard tire wall 42 must usually bend around the outer flange 66, forming a concave radially inward outboard surface. The tire 40 is not specifically designed to be mounted on such a wheel 60 and may be subject to unintended contortion forces along the outboard tire wall 42, particularly near the radially outward edge of the outer flange 66, which could strain or cause excessive wear on the tire 40. Second, the outboard tire wall 42 often has words on its face, including the brand/model of the tire and the tire specifications (such as the tire volume and recommended tire pressure). The outer flange 66 may, depending upon its size and the relative positioning of the words, cover all or a portion of these words on the outboard tire wall 42. Third, the simulation of a larger-diameter wheel with a low-profile tire in a perspective view may be less effective when the wheel 60 does not appear to interface tightly with the tire 40 on which it is mounted.

[0070] Referring to FIGURES 10-11, an embodiment of the tire 90 of the present invention includes an outboard tire wall 92, an inboard tire wall 96, and a tread 98. The outboard tire wall 92 preferably includes an outboard bead 100, a wheel protector 102, and a ledge 108. As used herein, the term "ledge" may include horizontal, curved, slanted, or sloping surfaces. The inboard tire wall 96 preferably includes an inboard bead 104. The opening in the center of the tire 90 is the wheel void 106. The tire beads 100, 104 are comprised essentially of indented rings formed on the inner radial edges of the respective inboard and outboard tire walls 92, 96. The wheel 60 is mounted within the wheel void 106 of the tire 90.

[0071] The wheel protector 102 on the outboard tire wall 92 extends in the outboard direction beyond the outboard wheel face 64. Preferably, the wheel protector 102 extends at least about 1/16 inch, and more preferably between about 1/16 inch and about 1/4 inch beyond the wheel face 64. When the vehicle on which the tire 90 is mounted comes in contact with a large stationary object (such as a curb), the flexible wheel protector 102 on

the outboard tire wall 92 touches the object instead of the wheel face 64. The wheel face 64 is thereby protected from scratching and bending. The width of the ledge 108 is preferably at least about 1/8 inch, and more preferably between about 1/8 inch and about 1/4 inch. Those of skill in the art will appreciate after reading this disclosure that many other widths for the ledge and wheel protector within and beyond these ranges are possible and are encompassed by the present invention.

[0072] In the illustrated embodiment, the radial location of the ledge 108 (i.e., the distance between the inner diameter d_i of the tire and the diameter d_L of the ledge 108) is about the same as or displaced a slight distance in the outwardly radial direction from the outer diameter of the 2-1/2-inch-wide outer flange 66 of the wheel 60. As previously explained, those of skill in the art will appreciate after reading this disclosure that the outer flange 66 may have many other widths, including 1 inch, 1-1/2 inches, 2 inches, 2-1/2 inches, 3 inches, 3-1/2 inches, or 4 inches. Thus, the diameter d_L would also have corresponding sizes of about 1 inch, 1-1/2 inches, 2 inches, 2-1/2 inches, 3 inches, 3-1/2 inches, or 4 inches to approximately match the size of the outer flange 66. The outer diameter d_p of the wheel protector 102 is somewhat larger than the diameter d_L of the ledge 108. The region between the inner diameter d_i of the tire wall 92 and the diameter of d_L of the ledge 108 is the flange seat 109. The width W_{fs} of the flange seat 109 is preferably at least about one-quarter of the width of the outboard tire wall 92 (as measured along the tire wall 92 from the inner diameter d_i to the outer tire diameter d_t where the tread 98 begins). More preferably, the width W_{fs} of the flange seat 108 is at least about one-third, and most preferably at least about one-half, of the width of the outboard tire wall 92. Many other sizes within and beyond these ranges and examples are encompassed by the present invention. If the flange seat 109 and outer flange 66 do not extend radially far enough, the desired simulation is less effective. If they extend too far, the vehicle on which the wheel is mounted would undesirably appear to be riding on its wheels with little or no tire visible.

[0073] In the embodiment of FIGURE 11, the inboard bead 104 is intended to correspond to the height of the inboard lip 68, and is similar in shape and size to the inboard bead 50 of a typical tire of the prior art (see FIGURE 5). Any words written on the outboard tire wall 92 are preferably positioned above the flange seat 109 so that such words are fully

visible after the wheel 60 has been mounted within the tire 90 and the outer flange 66 covers up substantially all of the flange seat 109.

[0074] In the embodiment of FIGURE 11A the tire 90 includes flange seats 109 on the inboard and outboard sides. The tire 90 is therefore more symmetric and balanced. Advantageously, during manufacturing and installation of the tire 90 in FIGURE 11A, it is unnecessary to be concerned with the inboard or outboard orientation of the tire 90. In the embodiment of FIGURE 11B, the tire of FIGURE 11A has been mounted on the wheel of FIGURE 7D with a detachable inboard flange.

[0075] The flange seat 109 is preferably contoured to generally match the interior faces of the flanges 66, 77. The flange seat 109 is also preferably constructed to be substantially more rigid than the remainder of the outboard tire wall 92, the tread 98, and/or the inboard tire wall 96. The rigidity of the flange seat 109 (on the outboard and/or inboard tire walls) is intended to deflect or transfer at least a portion of the flexing of the tire radially outwardly to the peripheral areas of the tire. In this way, the radially inward portion of the tire, which may be near or even touching the flanges 66, 77 of the wheel 60, will be less likely to press forcefully against the flanges 66, 77 possibly causing them to bend or to produce undue wear on the tire walls. The shielding of the flange 66, 77 by the rigidity of the flange seat 109 is especially advantageous in extreme driving conditions, such as in tight turns, under heavy loads, or when a tire passes into a depression in the road at high speeds.

[0076] Those of skill in the art will appreciate after reading this disclosure that the rigidity of the flange seat 109 may be increased by any number of methods known in the art such as, for example, including or modifying the characteristics of imbedded radial belts, heating and/or compressing the rubber material, or otherwise changing the density or composition of the rubber material of the tire wall in this region.

[0077] The flange seat 109 allows the outer flange 66 to be seated within the tire wall 92 in a manner that more closely simulates a large-diameter wheel mounted within a low profile tire. Even in a perspective view, it would be difficult for a casual observer to detect that the barrel 70 of the wheel 60 is not commensurate in size with the outer diameter of the outboard face 64 of the wheel 60, and that the tire 90 is actually much wider than it appears from the inner radial edge of the tire wall 92 to the tread 98.

[0078] In the illustrated embodiment, there is a relatively small gap 111 between the flange seat 109 and the outer flange 66. The gap 111 permits the flange seat 109 to flex and bend a small amount under normal driving conditions. If there were a substantial gap between the outer flange 66 and the outboard tire wall 42, the effectiveness of the simulation of a large-diameter wheel would be greatly diminished because the outer flange 66 may appear to be separated from the rest of the wheel, and the underlying tire wall 42 may be visible behind the outer flange 66. The flange seat 109 could also be constructed such that there is no gap between the flange seat 109 and the outer flange to achieve a tighter fit.

[0079] The lengths of each of the outboard and inboard tire walls 92, 96 are each preferably in the range of about 3 1/2 inches to 5 1/2 inches. Moreover, the distance between the tread 98 and the inner diameter of the outboard tire wall 92 is preferably about the same as the distance between the tread 98 and the inner diameter of the inboard tire wall 96. If either of the tire walls 92, 96 were substantially longer than the other, the tire might be subject to unbalanced stresses or wear, and perhaps require a specialized fitting for the wheel on which the tire is mounted. The lengths of the inboard and outboard tire walls 92, 96 could be different, especially if the tire 90 were designed to be mounted on a modified wheel wherein the inboard and outboard diameters of the barrel 70 were not the same.

[0080] FIGURE 12 is a side view of another embodiment of a wheel 110 of the present invention with the tire 90 of FIGURE 10 mounted thereon. The wheel 110 is similar to the wheel 60 of FIGURES 6, 7, 9, and 11, but the barrel 112 is divided into an outboard portion 116 and an inboard portion 118 along a vertical interface 114. In the wheel industry, a wheel with such a divided barrel is commonly referred to as a "two-piece" wheel. As shown in FIGURE 13, the outboard portion may be further divided into an outboard face 119 and a middle portion 117. The wheel 110 is referred to in the wheel industry as a "three-piece" wheel. The various portions 116, 119, 117 of the wheel 110 may be detached from the inboard portion 118 of the wheel 110 by removing securing bolts (not shown). The embodiments of FIGURES 12 and 13 could also be used with the flanges, wheel face, and/or tires of FIGURES 7A-D, 8A-8B, and 11A-B.

[0081] In general, two- and three-piece wheels are more costly than one-piece wheels and are targeted at consumers who drive more expensive vehicles. Many high-end

vehicles come stock from the factory with two- and three-piece wheels. The inboard portion 118 of such wheels usually has a specialized size and shape to fit a particular type of vehicle axle or to accommodate specially designed components in the braking, steering, or suspension systems. It would not be cost-effective for most after-market wheel manufacturers to make different types of one-piece wheels for each of the different types of vehicles that require specialized wheel parts. Instead, the vehicles come with two- or three-piece wheels having a specialized inboard portion 118, but an interchangeable front face 116 and/or middle portion 117. In this way, the consumer can obtain an after-market wheel with a stylish appearance, but the wheel manufacturer does not need to undertake the expense of building and marketing different one-piece wheels for the many different varieties of specialized wheel sizes.

[0082] The individual costs of manufacturing two- and three-piece wheels may be higher, but the overall volume of such wheel sales in the industry is much lower than the sales volume for one-piece wheels. For this reason, one-piece wheels are generally made with expensive, high-volume casting equipment, whereas two- and three-piece wheels are machined from blocks of alloy metal. It is generally less expensive to re-tool the machining process to manufacture a larger wheel or a specialty wheel than it would be to re-tool the high-volume casting equipment. Thus, it is contemplated that the present invention may be especially suited for the production of machined two- and three-piece wheels sizes that may not yet even be available in one-piece molded sizes.

[0083] It is also contemplated that the various embodiments of the present invention may be especially suited for use with small vehicles and/or stock wheels for vehicles. Vehicle manufacturers are constantly searching for products that enhance the performance and/or aesthetics of their vehicles without adding significantly to the overall cost. This principle is particularly important in connection with less expensive cars. The present invention encompasses a wide range of enhanced wheel sizes that provide the appearance of an expensive upgrade for a relatively small amount of additional cost.

[0084] While the foregoing description sets forth various examples and details relating to preferred embodiments, it should be appreciated that the description is illustrative only and should not be construed as limiting the invention. Thus, the scope of this

disclosure is not to be limited by the illustrations or the foregoing descriptions thereof, but rather solely by the appended claims.

WHAT IS CLAIMED IS:

1. A wheel adapted to be mounted within a tire and adapted to be attached to a vehicle, the wheel comprising:

a central hub having an inboard side and an outboard side;

an inboard lip formed on the inboard side of the hub and extending radially outwardly;

an outer flange integrally formed on the outboard side of the hub and extending radially outwardly, the outer flange having an outer diameter greater than an outer diameter of the inboard lip so as to give an appearance of a larger-diameter wheel than would otherwise exist if the outer flange had the same diameter as the inboard lip; and

a plurality of at least one of either protrusions, indentations, or slits formed on the outboard side of the wheel and extending across at least a portion of the outer flange to enhance said appearance of a larger-diameter wheel.

2. The wheel of Claim 1, wherein the outer diameter of the outer flange is at least about 3/4 inch greater than the outer diameter of the inboard lip.

3. The wheel of Claim 1, wherein the outer flange is adapted to abut against the outer wall of the tire when mounted thereon after the tire is pressurized.

4. The wheel of Claim 1, wherein the central hub comprises a plurality of spokes and the integral design on the outer flange gives the appearance that the spokes extend across at least a portion of the outer flange.

5. A wheel, comprising:

a central hub having an inboard side and an outboard side;

an outer flange removably attached to the outboard side of the hub and extending radially outwardly, the outer flange having an inner diameter and an outer diameter, wherein the difference between the inner and outer diameters is at least about 1 inch; and

a plurality of at least one of either protrusions, indentations, or slits formed on the outboard face of the wheel and extending across at least a portion of the outer

flange, whereby the wheel is adapted to give an appearance of a larger-diameter wheel when mounted within a tire.

6. The wheel of Claim 5, wherein the difference between the inner and outer diameters of the outer flange is at least about 1-1/2 inches.

7. The wheel of Claim 5, wherein the outer flange is integral with an outboard face removably attached to the outboard side of the hub.

8. The wheel of Claim 5, wherein the inboard side of the central hub comprises an inboard lip extending radially outwardly, and the outer flange is at least about twice as wide as the height of the inboard lip.

9. The wheel of Claim 5, further comprising an inboard flange attached to the inboard side of the hub and extending radially outwardly, the inboard flange having an inner diameter and an outer diameter, wherein the difference between the inner and outer diameters of the inboard flange is at least about 1 inch.

10. The wheel of Claim 9, wherein the difference between the inner and outer diameters of the inboard flange is at least about 1-1/2 inches.

11. The wheel of Claim 9, wherein the difference between the inner and outer diameters of the inboard flange is approximately equal to the difference between the inner and outer diameters of the outer flange on the outboard face.

12. The wheel of Claim 9, wherein the inboard flange is removably attached to the inboard side of the hub.

13. The wheel of Claim 5, wherein the central hub comprises a plurality of spokes and the outer flange gives the appearance that the spokes extend across at least a portion of the outer flange.

14. A tire, comprising:

an inboard tire wall having an inboard bead;

an outboard tire wall having a wheel protector and a flange seat;

the outboard tire having an inner diameter, an outer diameter, and a width therebetween, and the inboard tire wall having an inner diameter, an outer diameter, and a width therebetween, the widths of the outboard and inboard tire walls being approximately the same;

the flange seat having an inner diameter, a ledge, and a width therebetween, and the inboard bead having an inner diameter, an outer diameter, and a width therebetween, the width of the flange seat being greater than the width of the inboard bead and the flange seat being more rigid than the remainder of the outboard tire wall;

wherein the flange seat is adapted to interface with an extended outer flange of a wheel when mounted thereon to thereby simulate the appearance of a low-profile tire on a large-diameter wheel.

15. The tire of Claim 14, wherein the ledge has in inboard edge, an outboard edge, and a width therebetween, the width of the ledge being at least about 1/8 inch.

16. The tire of Claim 14, wherein the width of the flange seat is at least about one-third of the width of the outboard tire wall.

17. A tire for enhancing a simulated appearance of a large-diameter wheel mounted within a low-profile tire, the tire comprising:

An outboard tire wall, an inboard tire wall, and a tread, the outboard tire wall having an inner diameter, an outer diameter, and a width therebetween, the width of the outboard tire wall being at least about 3-1/2 inches;

a flange seat formed on the outboard tire wall, the flange seat having an inner diameter, a ledge, and a width therebetween, wherein the width of the flange seat is at least about one-quarter as large as the width of the outboard tire wall; and

wherein the distance between the tread and the inner diameter of the outboard tire wall is about the same as the distance between the tread and the inner diameter of the inboard tire wall.

18. A wheel and tire adapted to be mounted within a tire and adapted to be attached to a vehicle, the wheel comprising:

(a) a wheel comprising:

(i) a central hub adapted to be attached to a vehicle, and the central hub having an inboard side, an outboard side, and a central axis;

- (ii) an inboard lip formed on the inboard side of the hub and extending radially outwardly;
- (iii) an outer flange integrally formed on the outboard side of the hub and extending radially outwardly, the outer flange having an inner diameter and an outer diameter, the outer diameter being greater than an outer diameter of the inboard lip, so as to give an appearance of a larger-diameter wheel than would otherwise exist if the outer flange had the same diameter as the inboard lip, and the outer flange having an inboard side, and an outboard side; , an upper portion, and a lower portion, the inboard side of the lower portion of the outer flange having a substantially convex surface, and the inboard side of the upper portion of the outer flange having a substantially flat surface; and
- (iv) a design pattern on the central hub that extends comprising a plurality of at least one of either protrusions, indentations, or slits formed on the outboard side of the central hub and extending across at least a portion of the outer flange of the wheel, the distance between the central axis of the hub to the furthest radial extent of the design pattern being greater than the distance between the central axis of the hub and the outer diameter of the inboard lip; to enhance said appearance of a larger-diameter wheel.

- (b) a tire comprising:
 - (i) an inboard tire wall having an inboard bead;
 - (ii) an outboard tire wall having a flange seat, the flange seat having an inner diameter, an outboard bead, and a ledge;

wherein the tire is mounted on the wheel such that the inboard side of the outer flange substantially overlaps, and is in close proximity with, the flange seat, the outer radial edge of the outer flange is juxtaposed in substantially facing relationship with the tire ledge, the inboard lip interfaces with the bead of the tire, the area of interface between the outer flange of the wheel and the flange seat on the outboard tire wall is substantially greater than the area of interface between the inboard lip and the bead on the inboard tire wall, and at least a portion of the outboard tire wall extends at least as

far in the outboard direction as the outboard face of the outer flange, so as to give an appearance of a

larger-diameter wheel mounted within a lower-profile tire.

19. The wheel and tire of Claim 18, wherein the outer diameter of the outer flange is at least about 3/4 inch greater than the outer diameter of the inboard lip.

20. The wheel and tire of Claim 18, wherein the outer flange is adapted to abut against the outer wall of the tire with substantially no gap therebetween when mounted thereon after the tire is pressurized.

21. The wheel and tire of Claim 18, wherein the central hub comprises a plurality of spokes and the pattern on the outer flange gives the appearance that the spokes extend across at least a portion of the outer flange.

22. The wheel and tire of Claim 18, wherein the difference between the inner and outer diameters of the outer flange is at least about 2 inches.

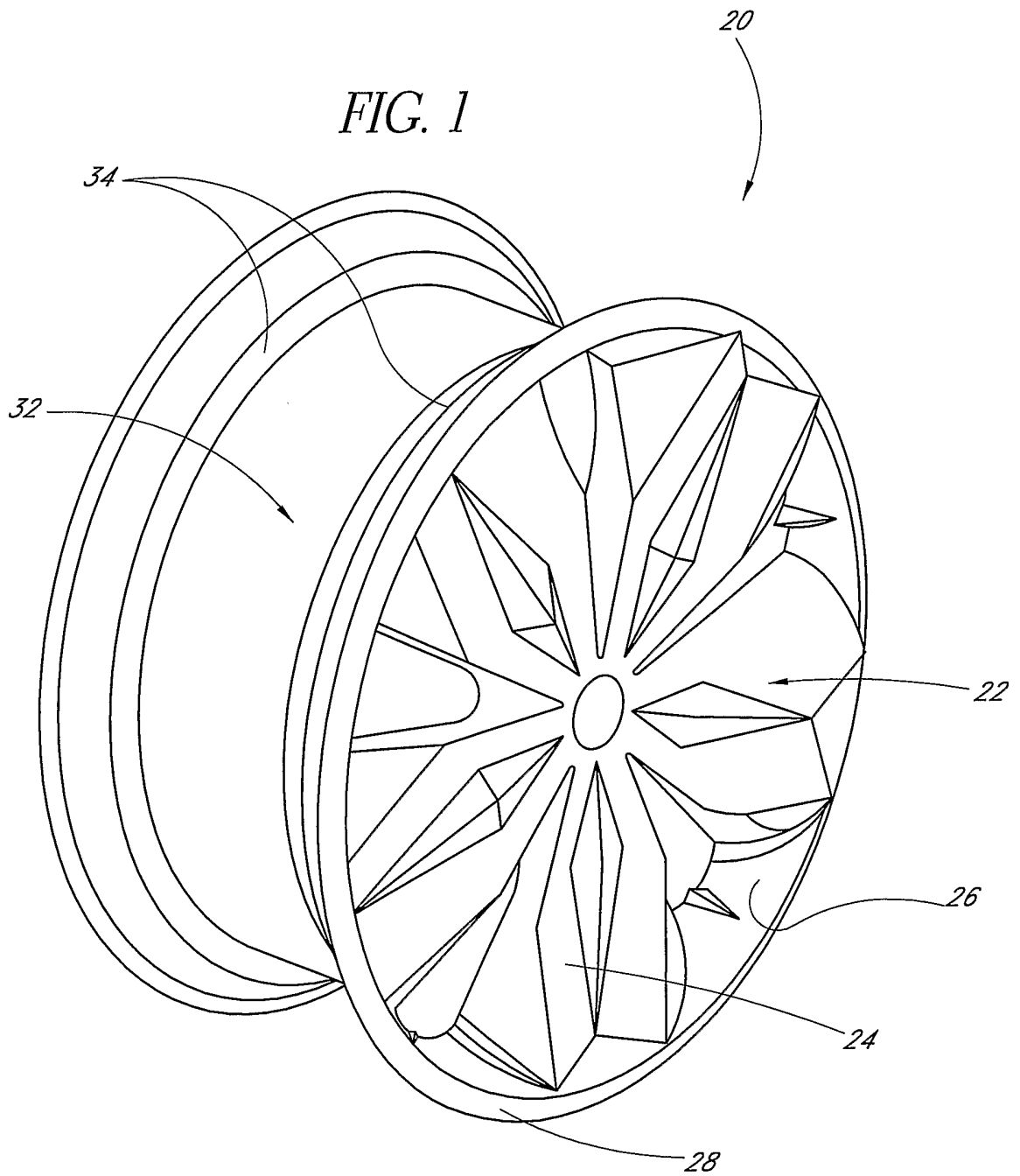

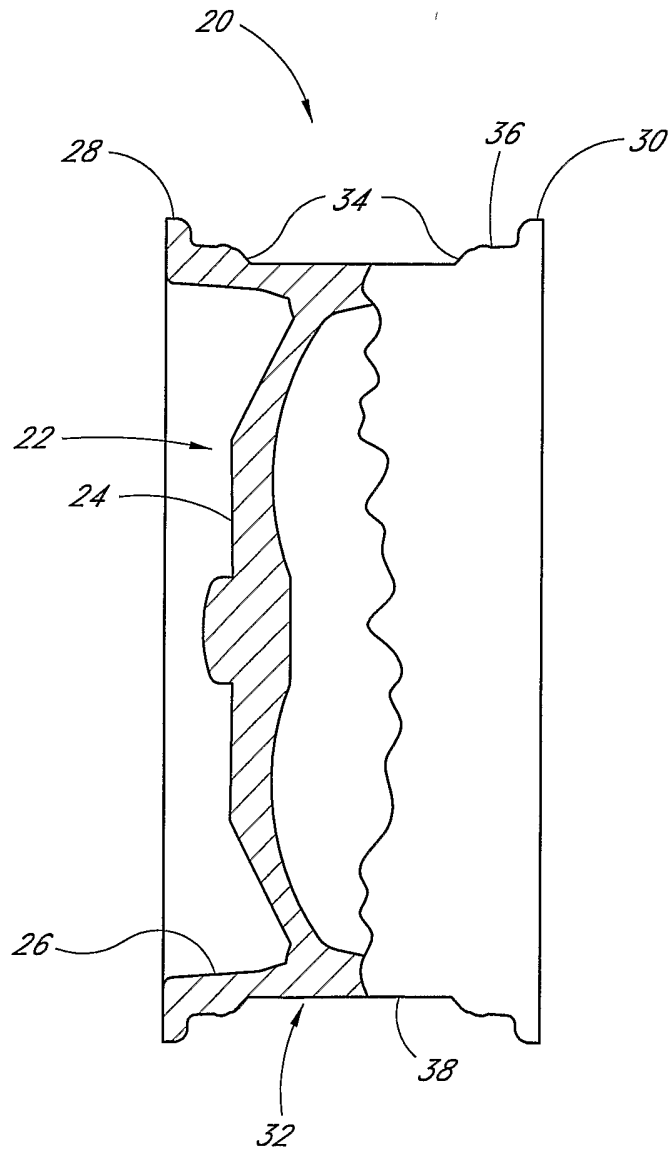

FIG. 2

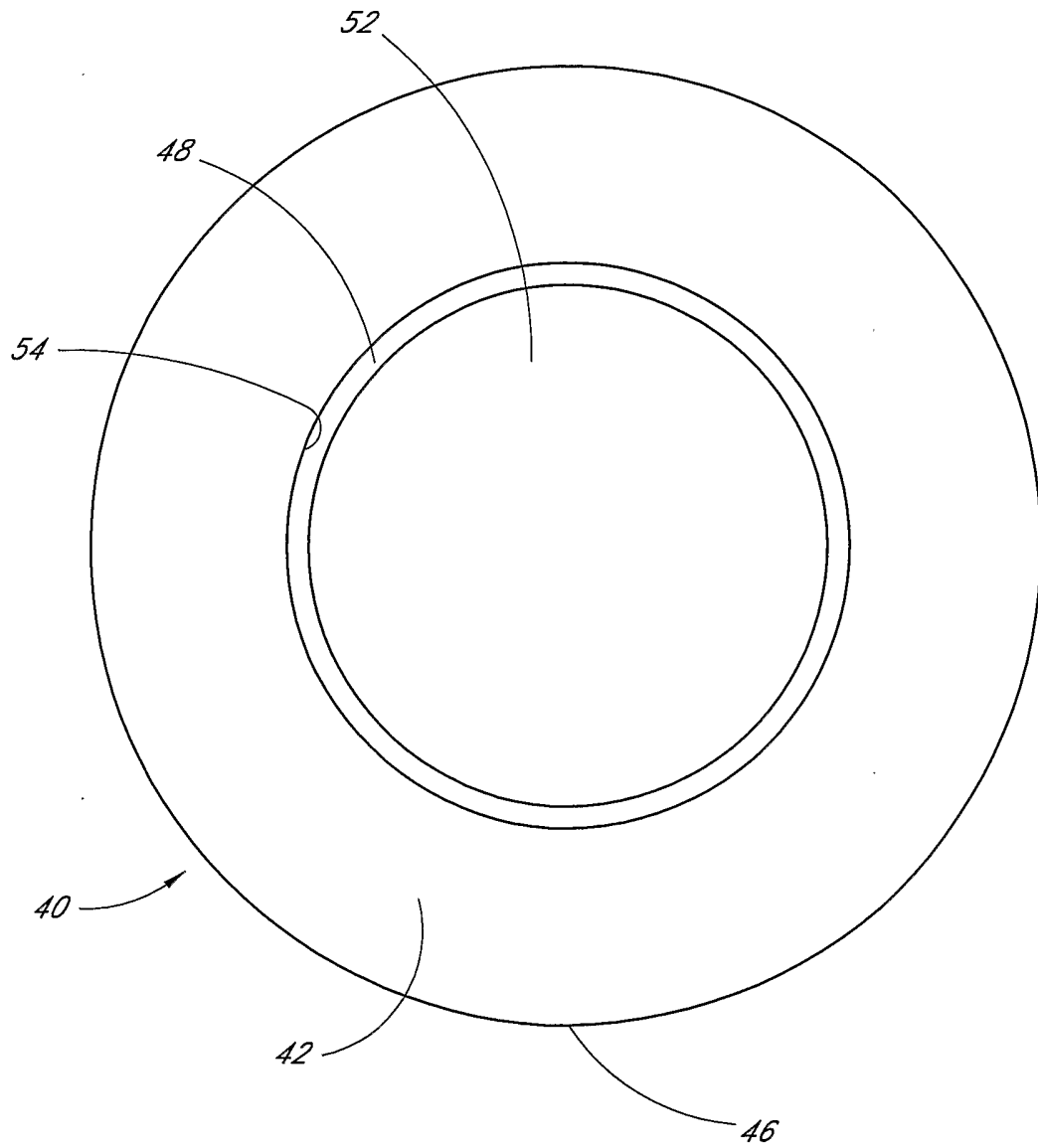

FIG. 3

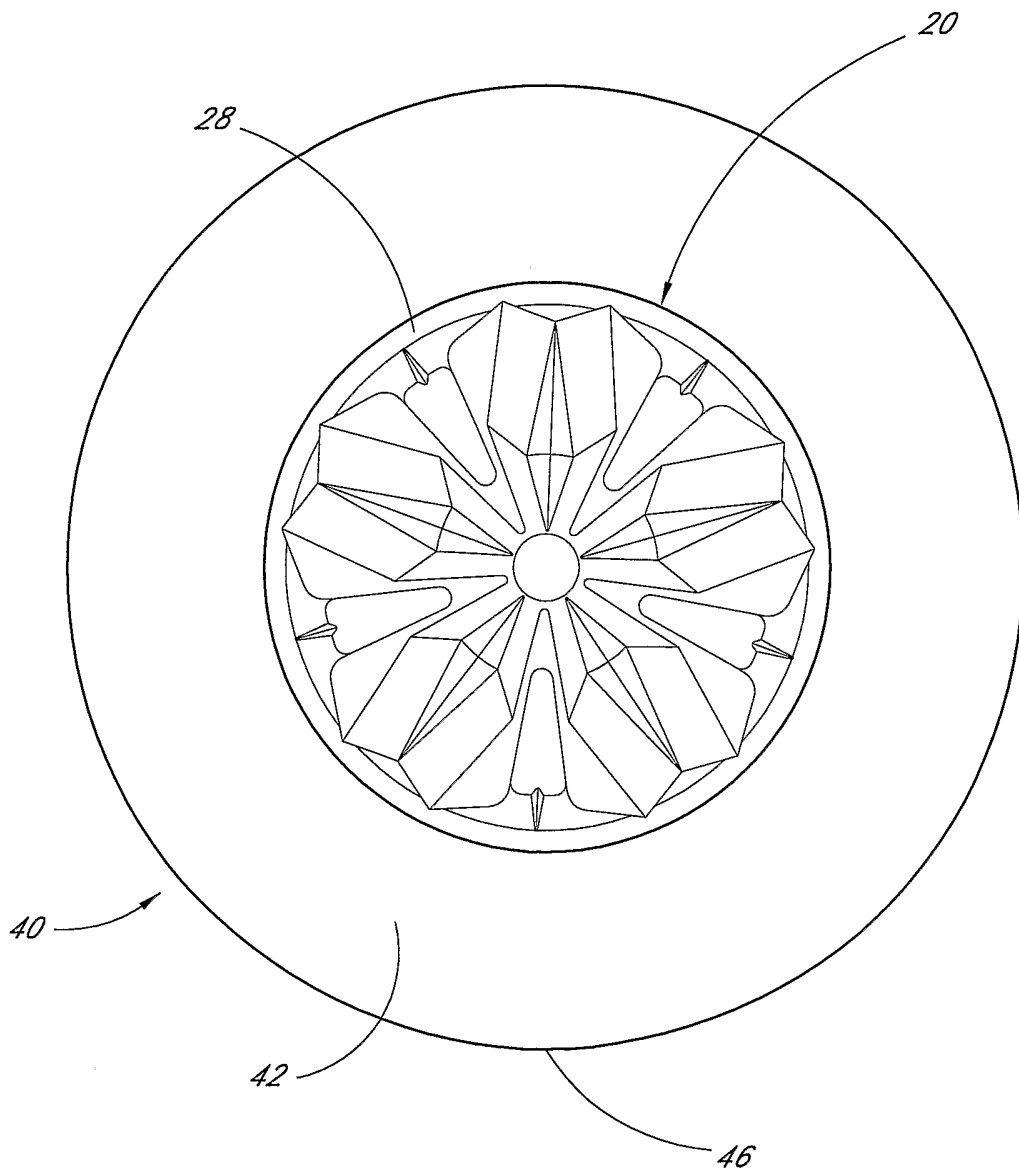

FIG. 4

5/21

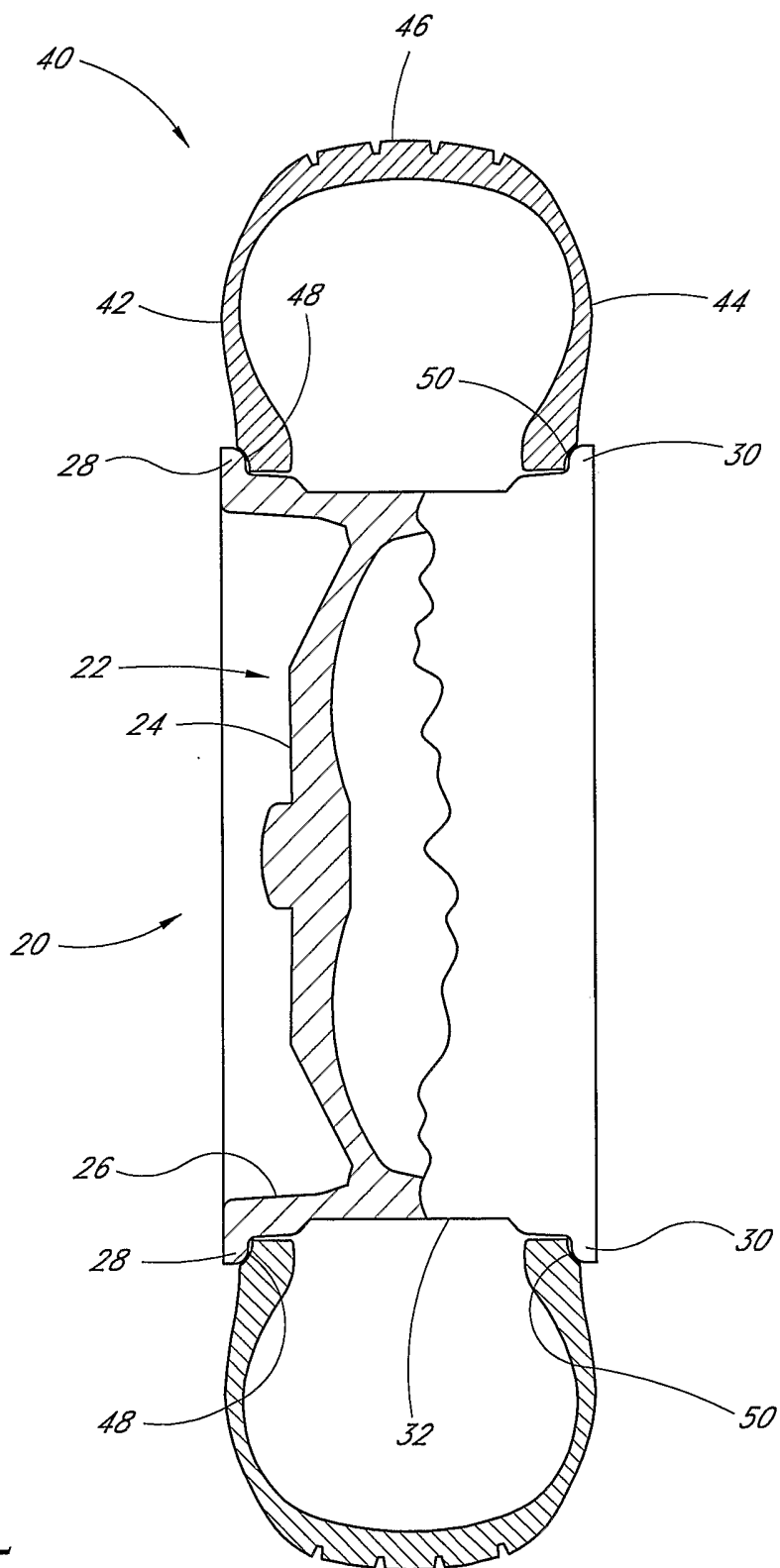
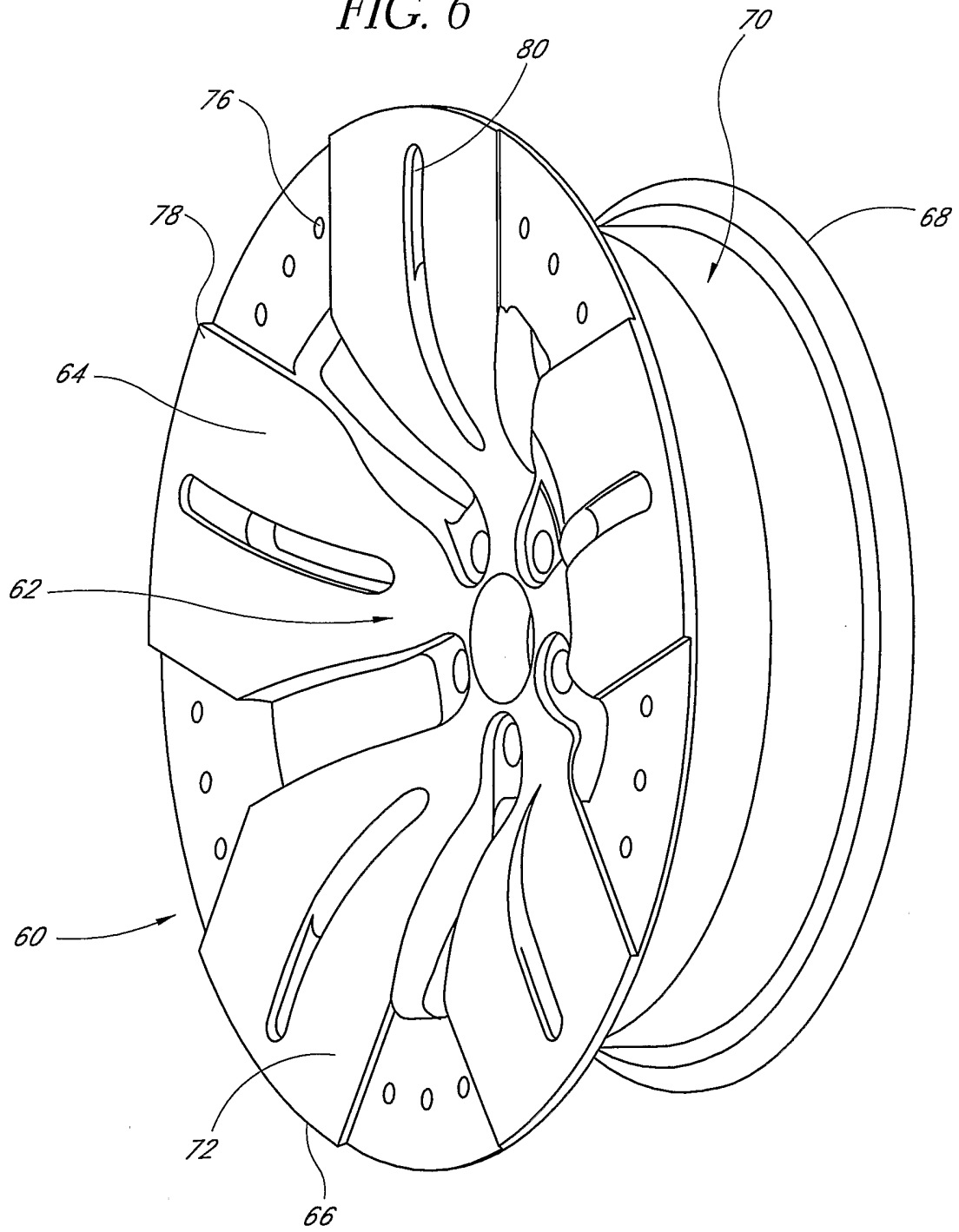

FIG. 5

FIG. 6



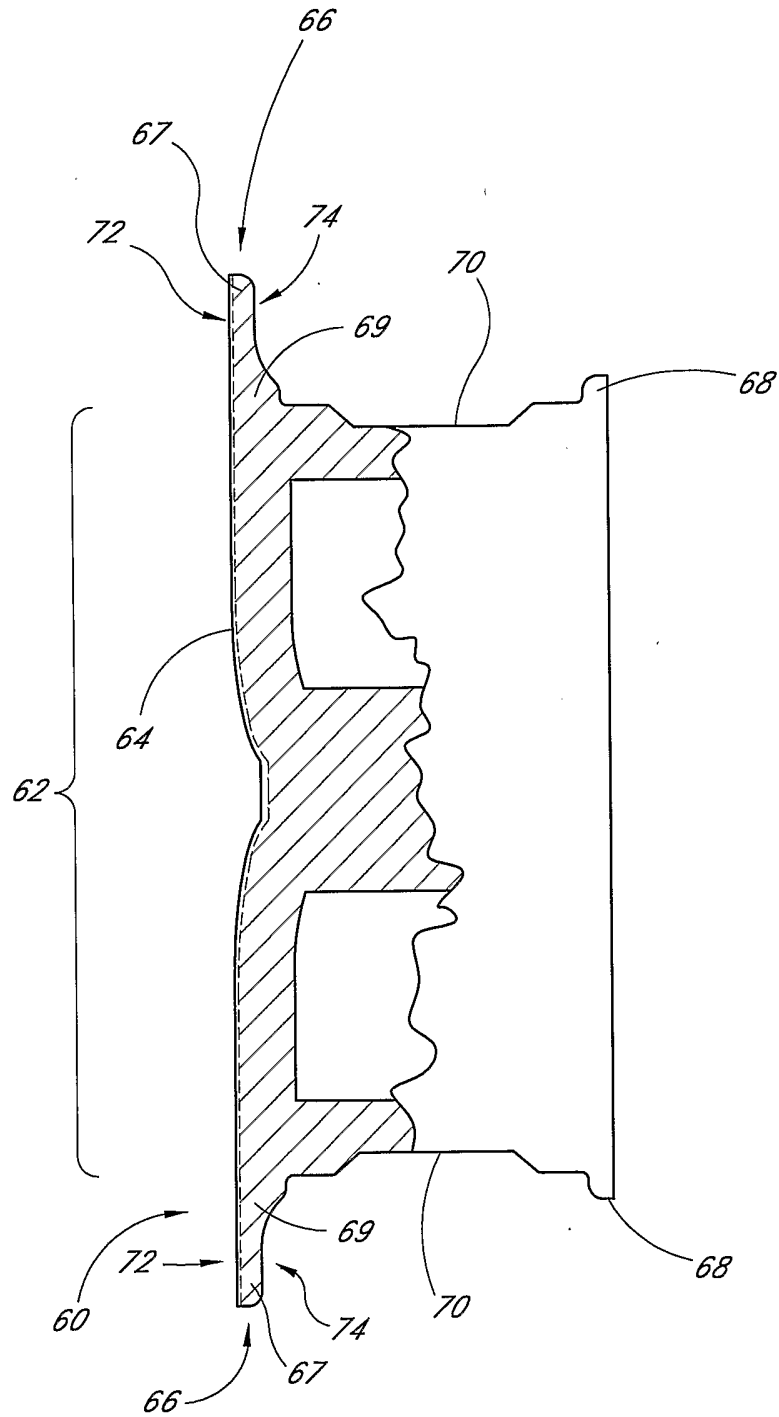

FIG. 7

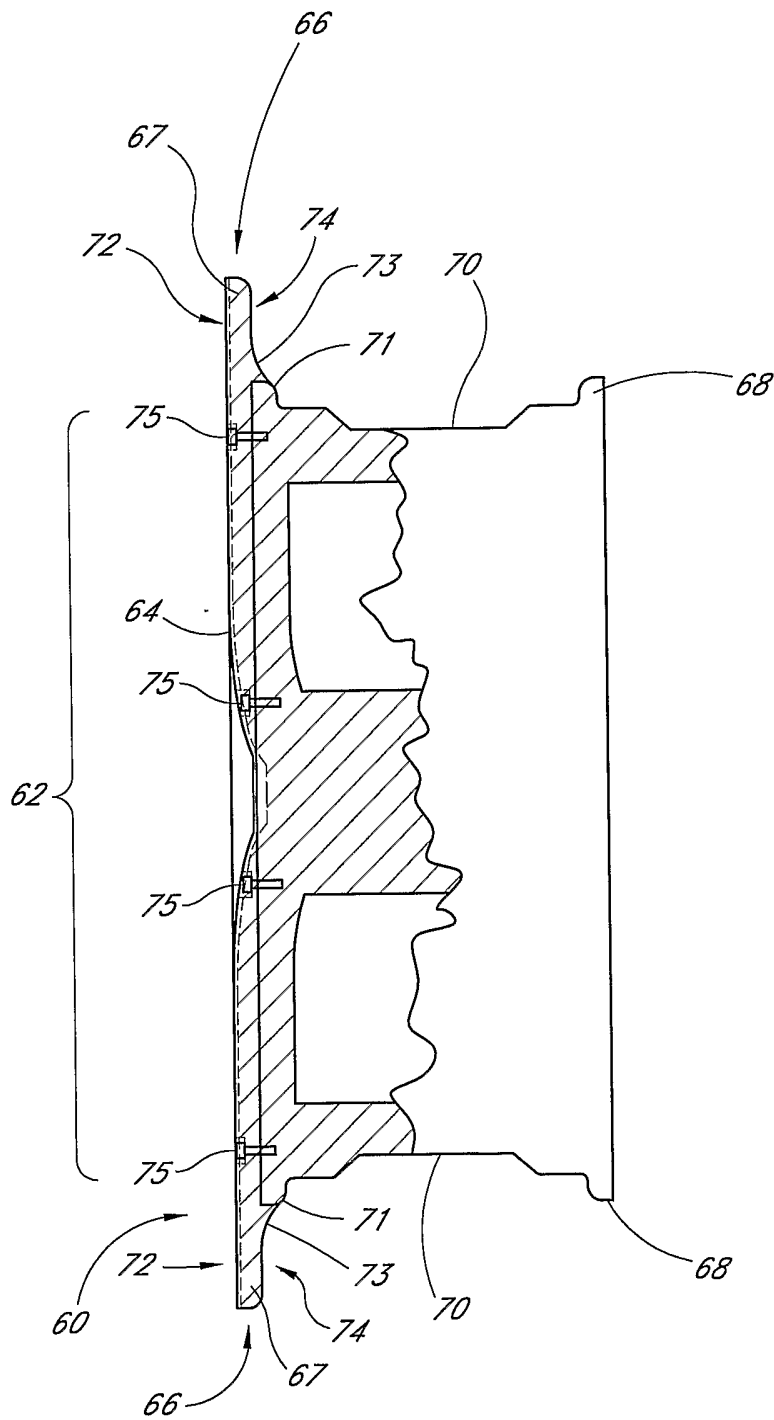

FIG. 7A

9/21

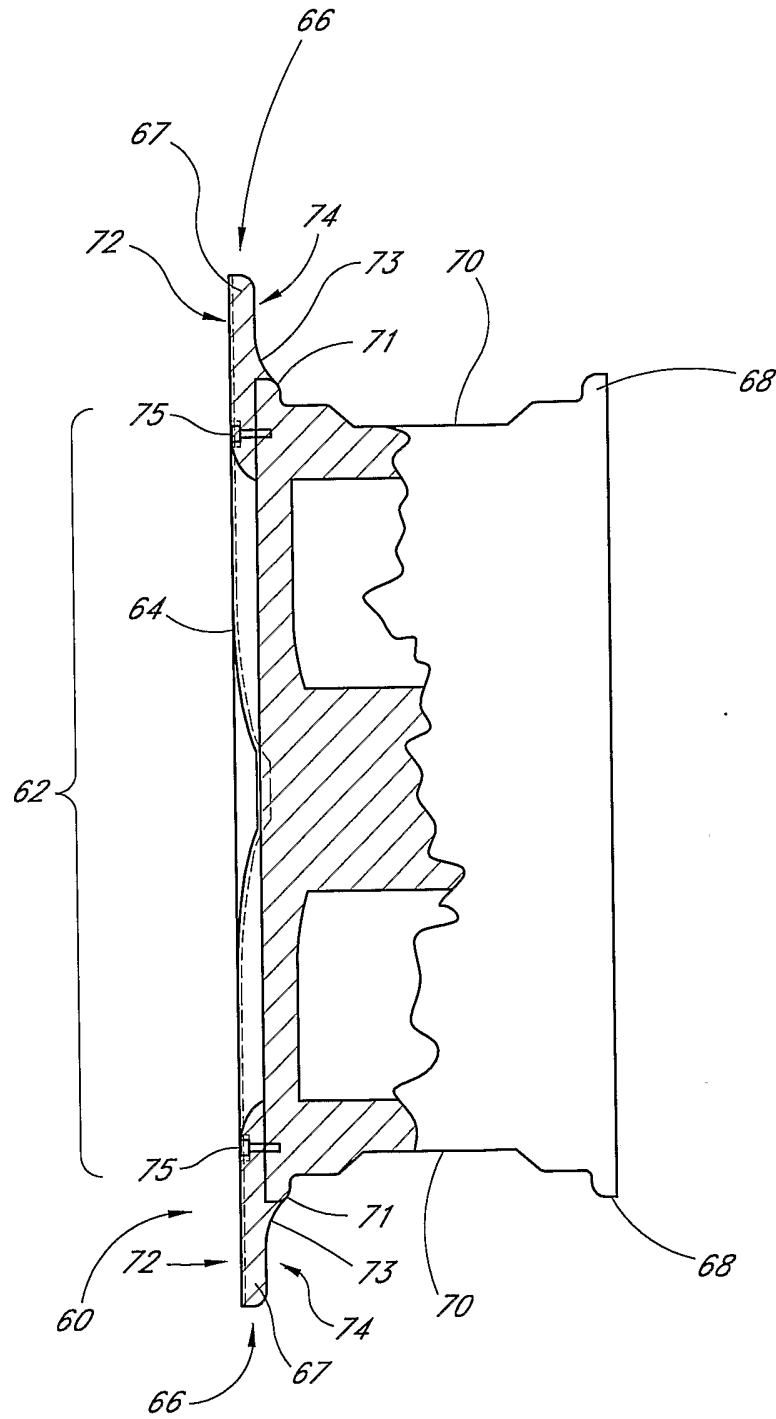

FIG. 7B

10/21

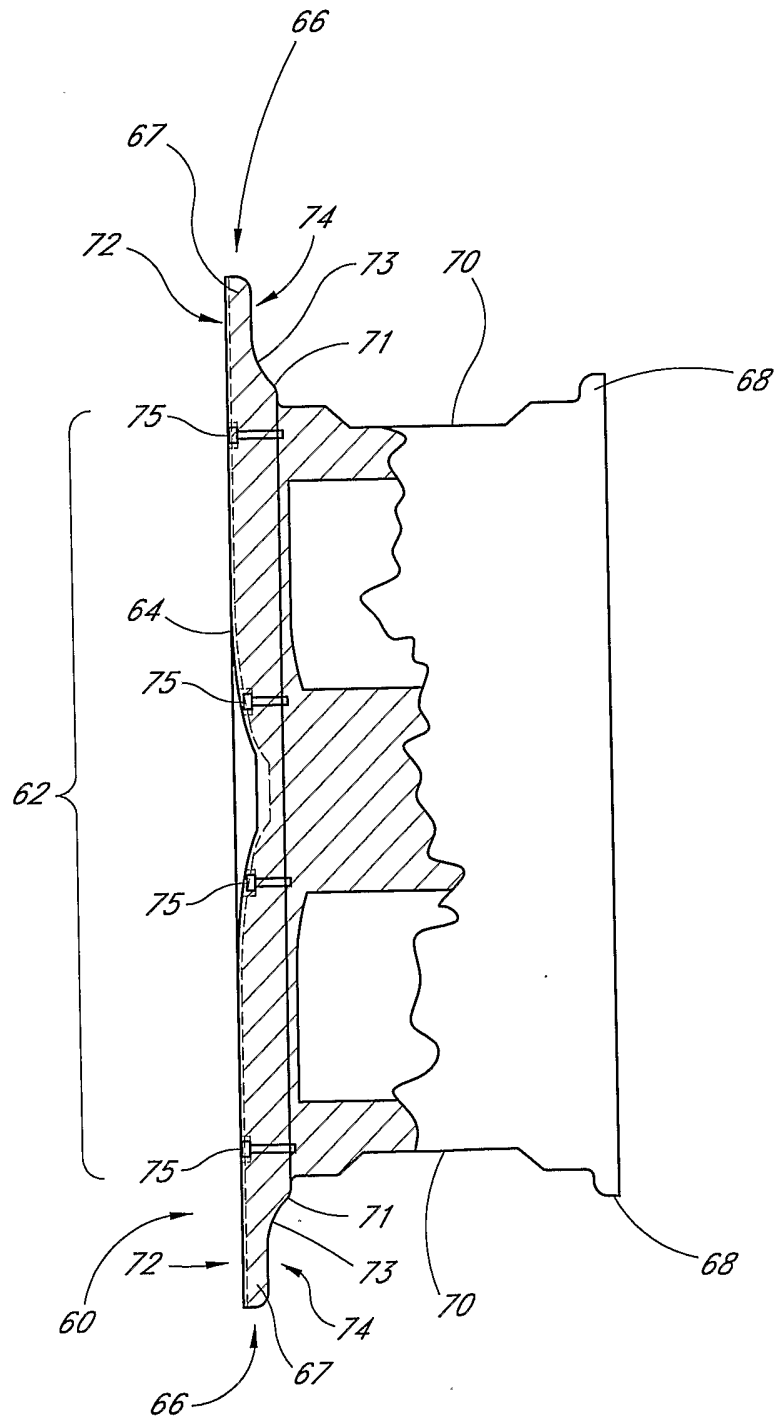

FIG. 7C

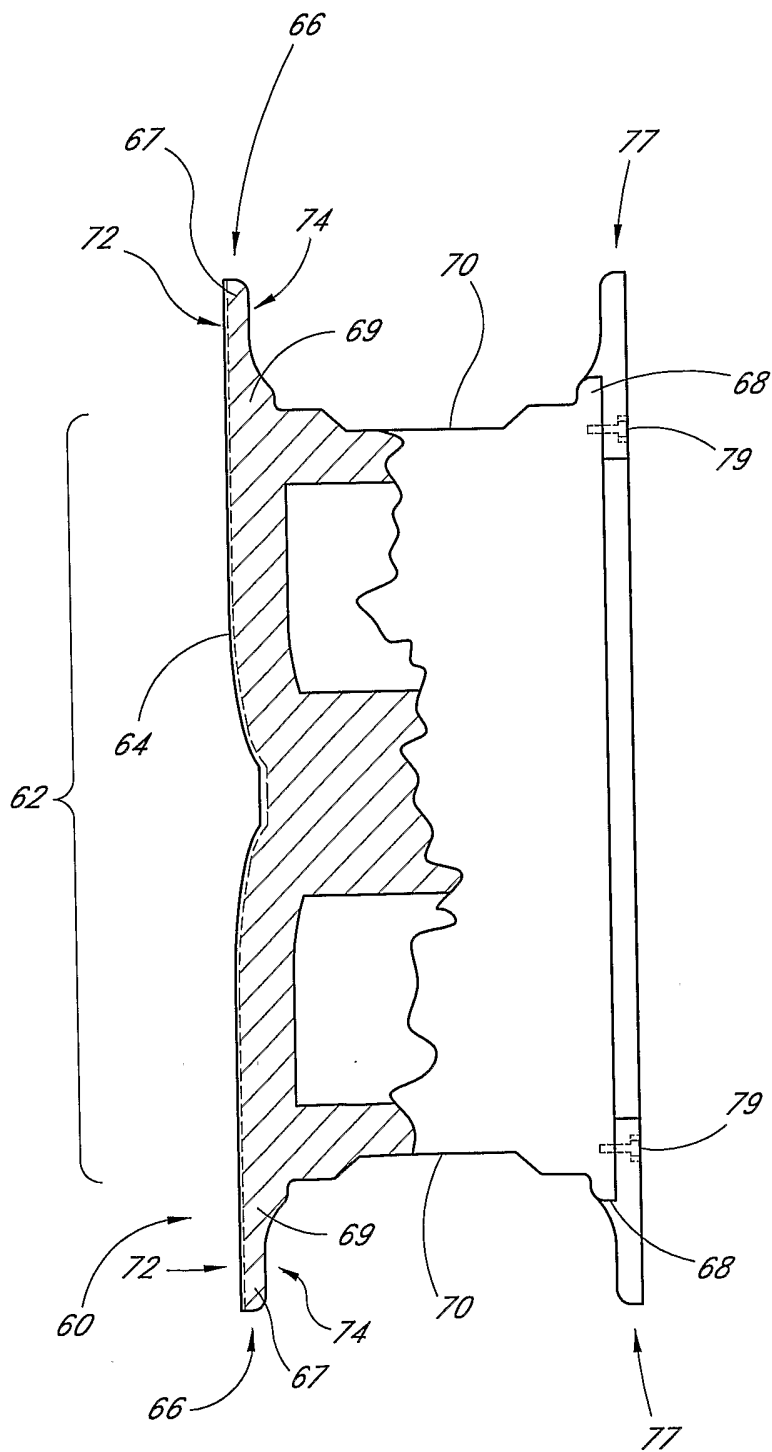

FIG. 7D

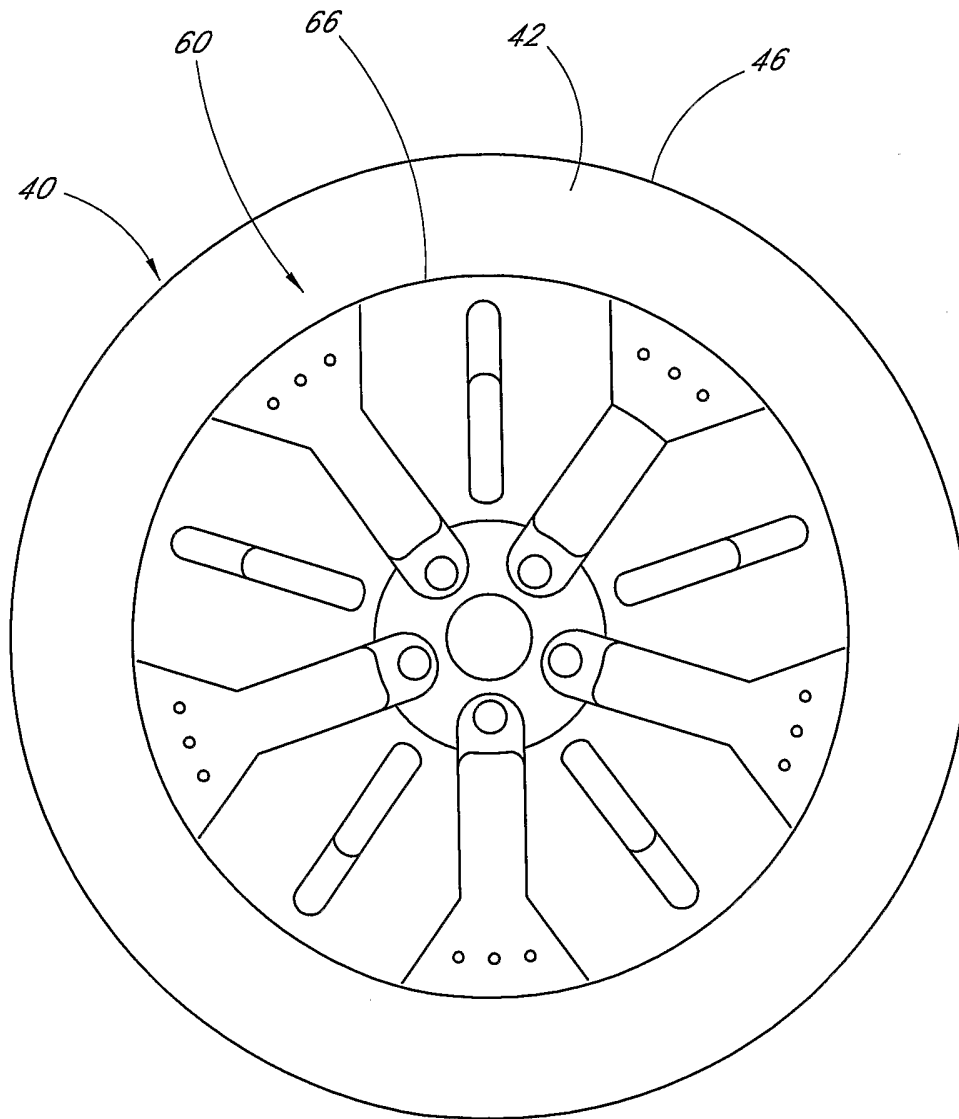

FIG. 8

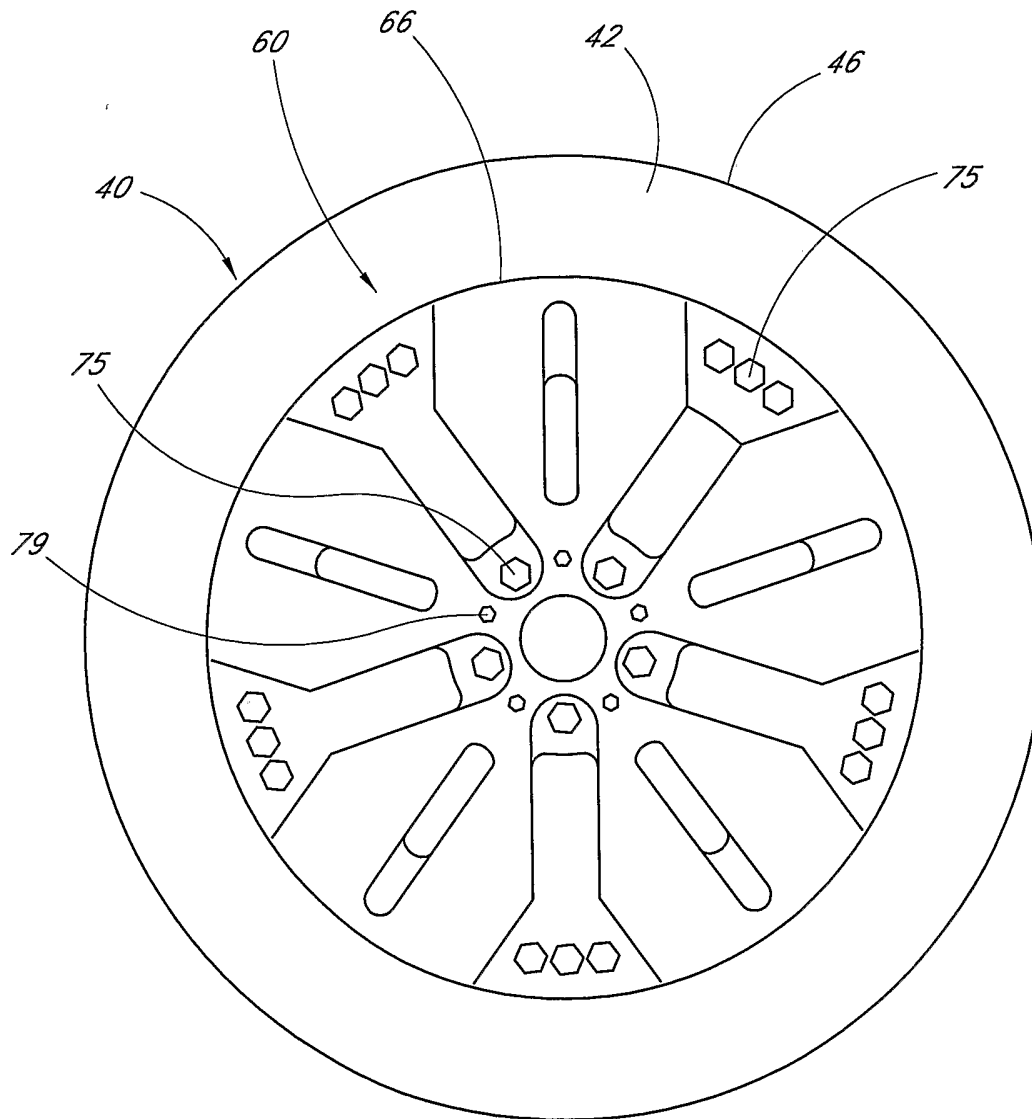

FIG. 8A

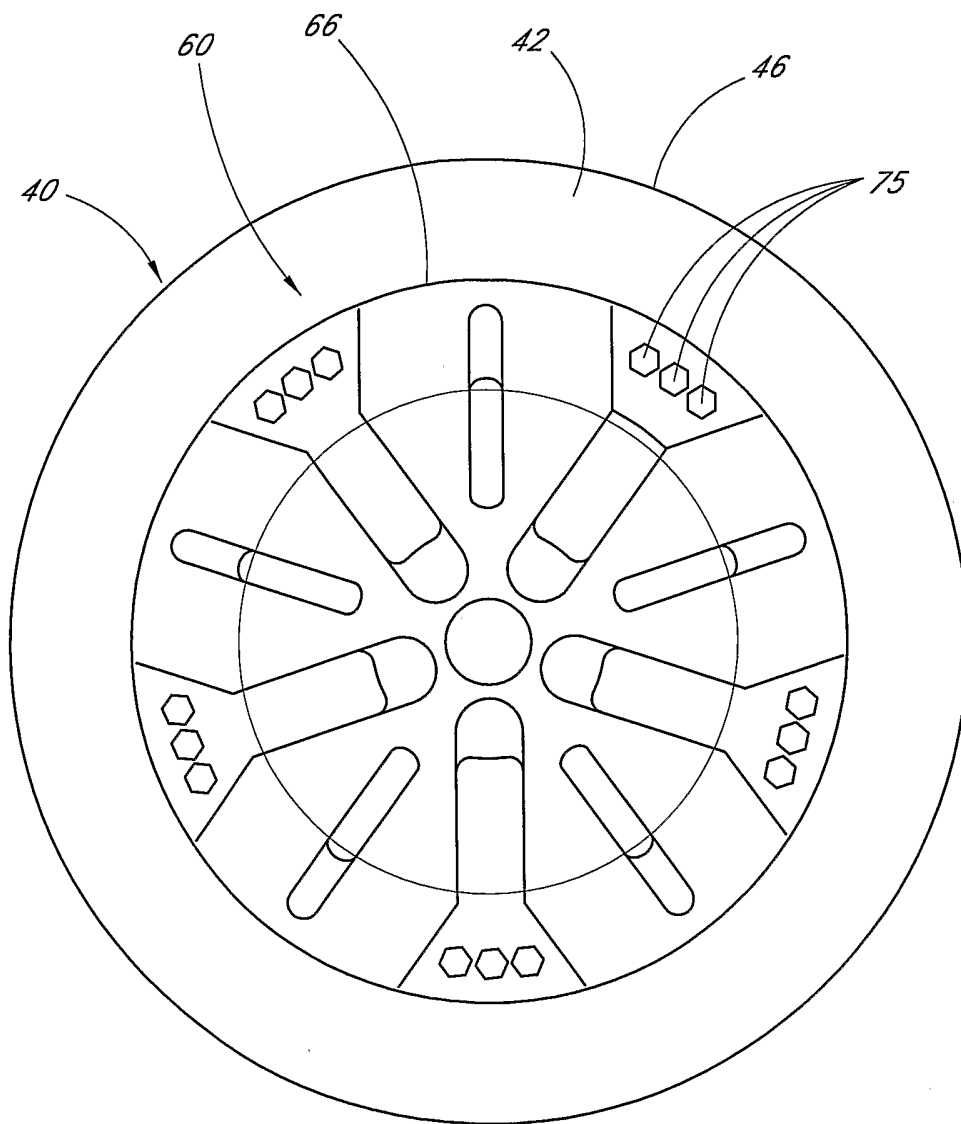

FIG. 8B

15/21

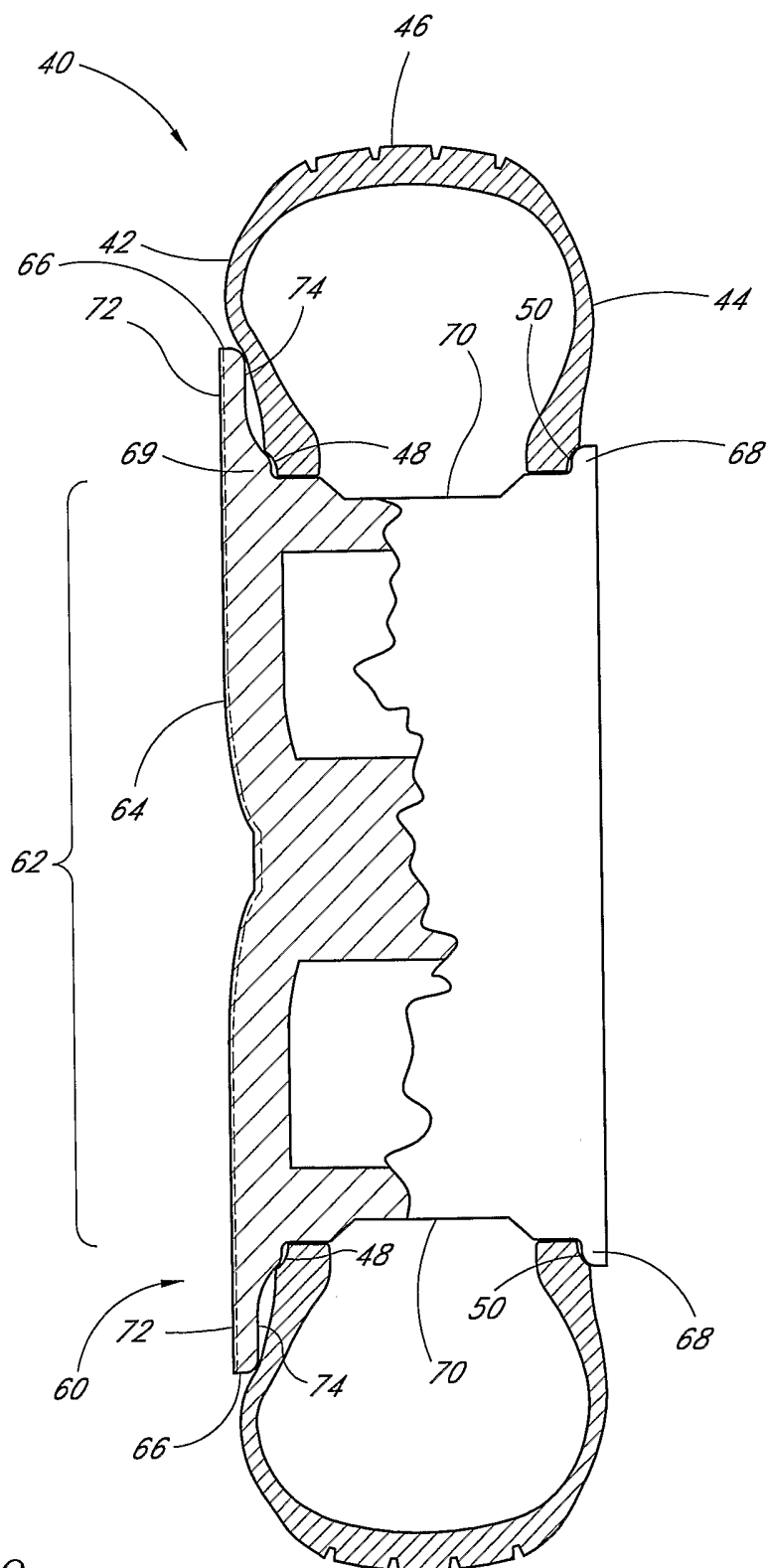
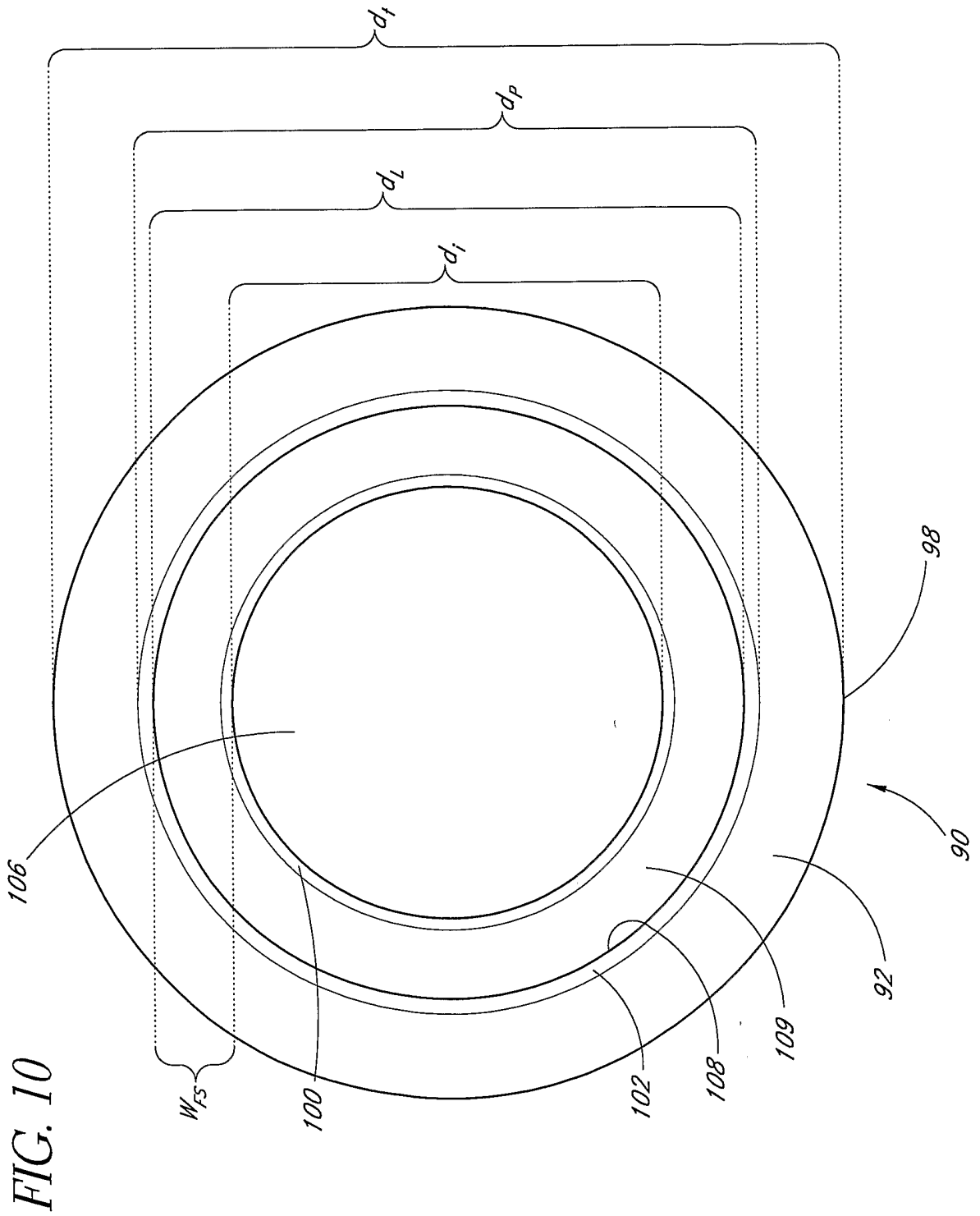

FIG. 9



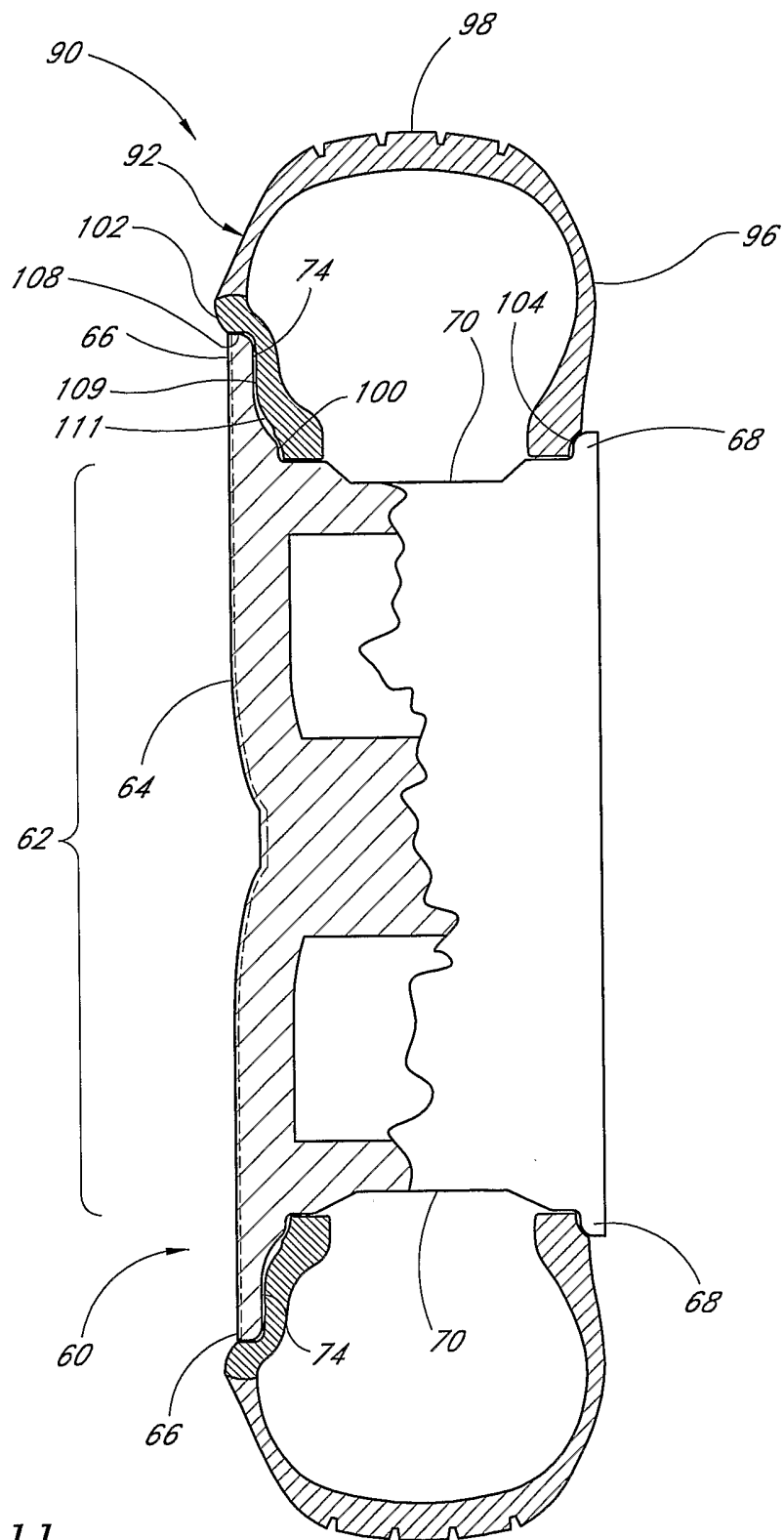

FIG. 11

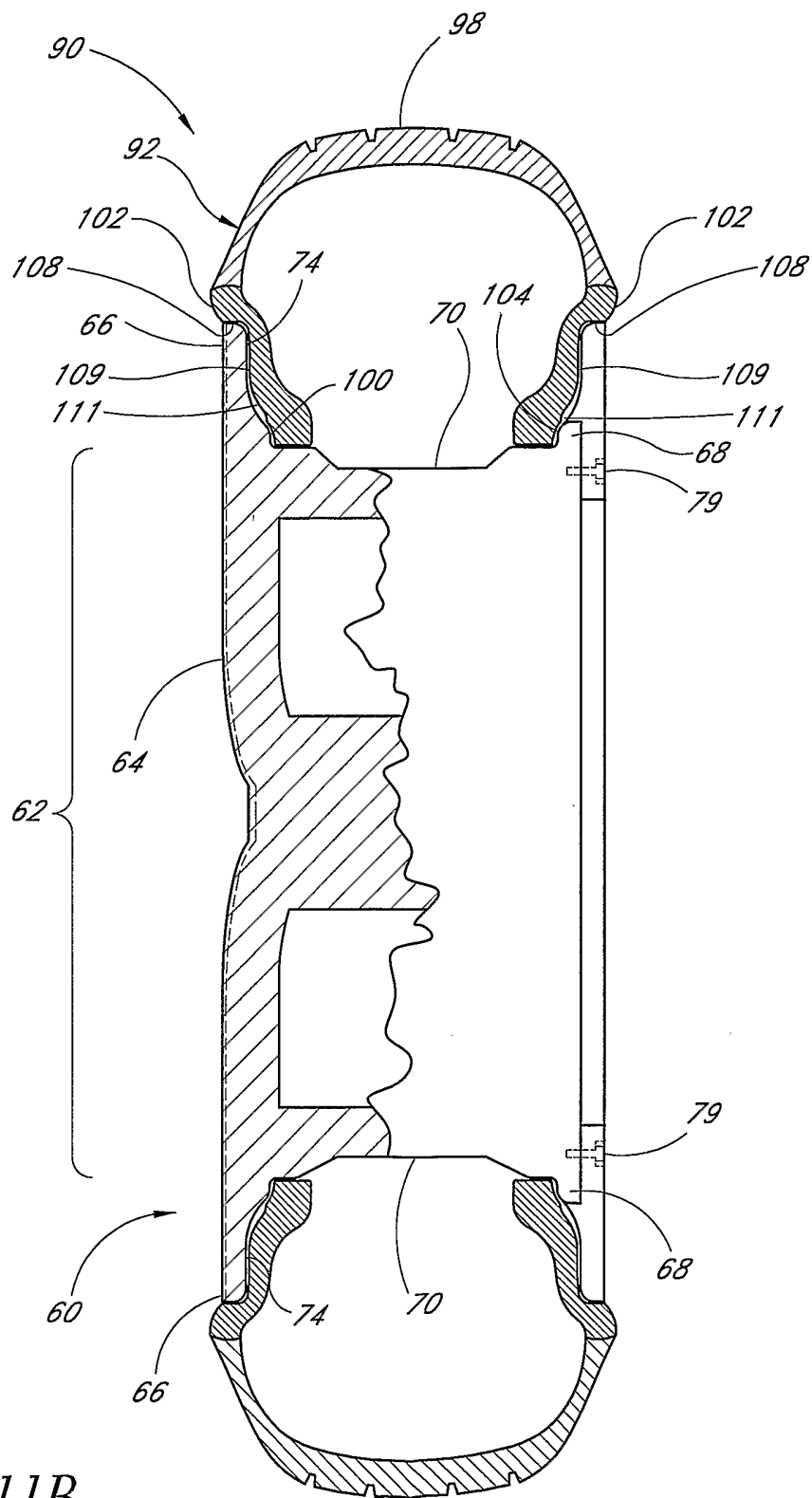

FIG. 11B

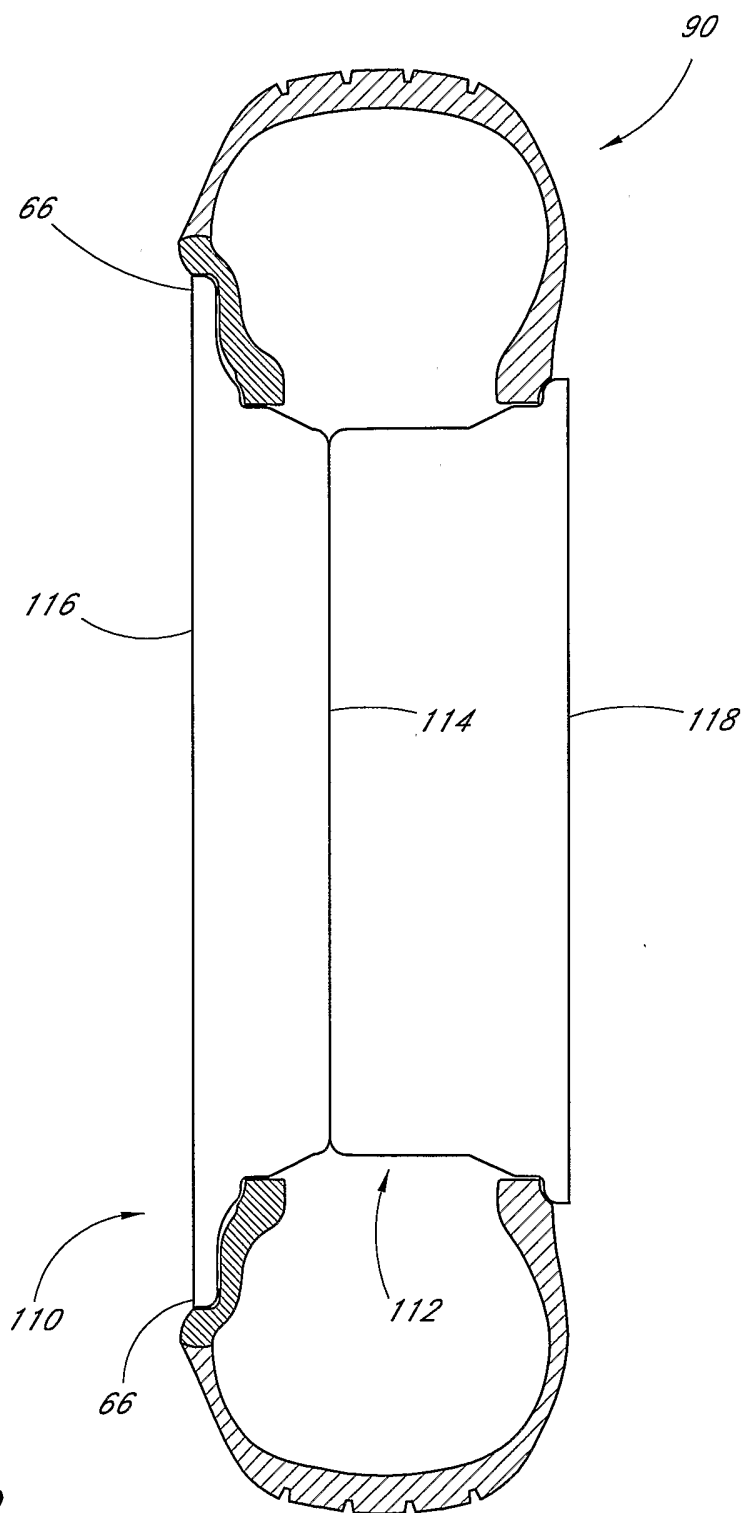

FIG. 12

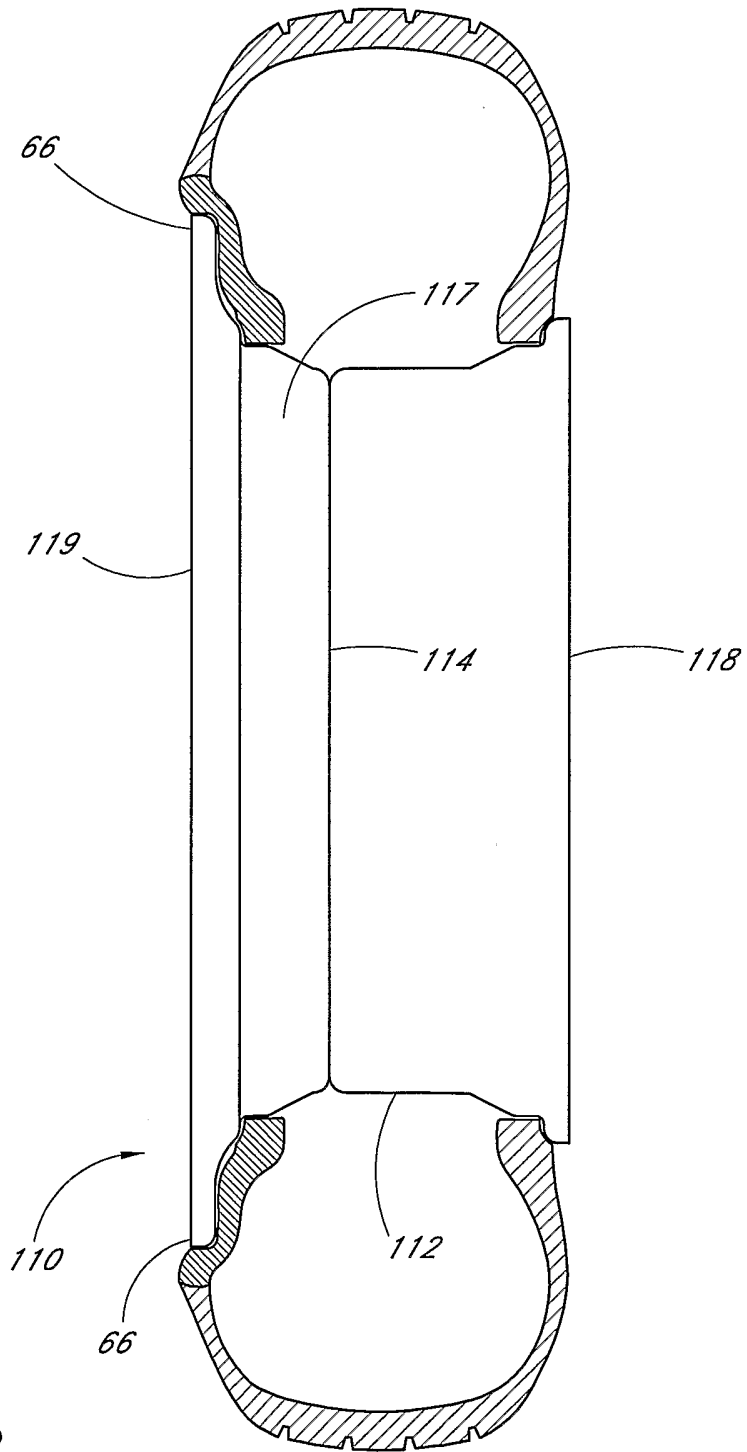

FIG. 13