

(No Model.)

J. T. CROWTHER.  
DUMPING CAR.

No. 244,795.

Patented July 26, 1881.

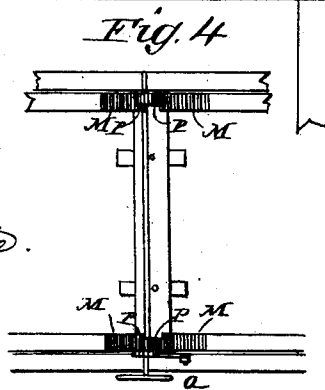
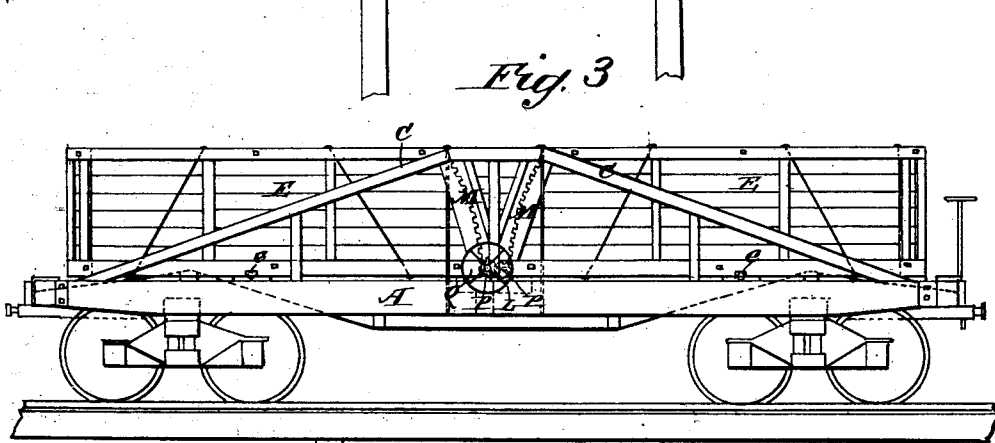
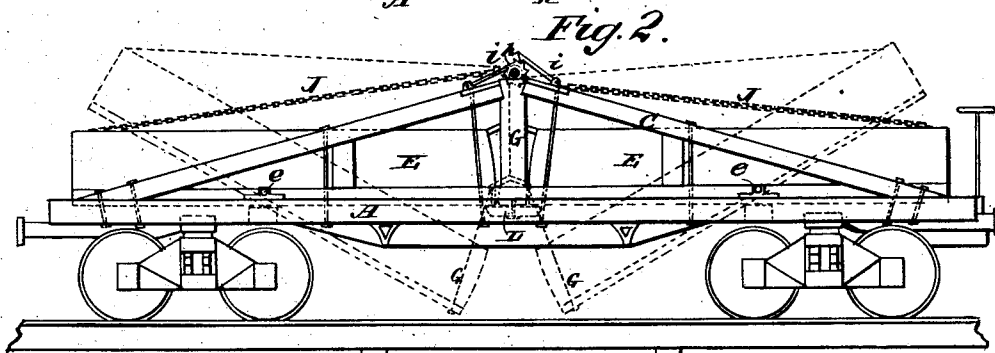
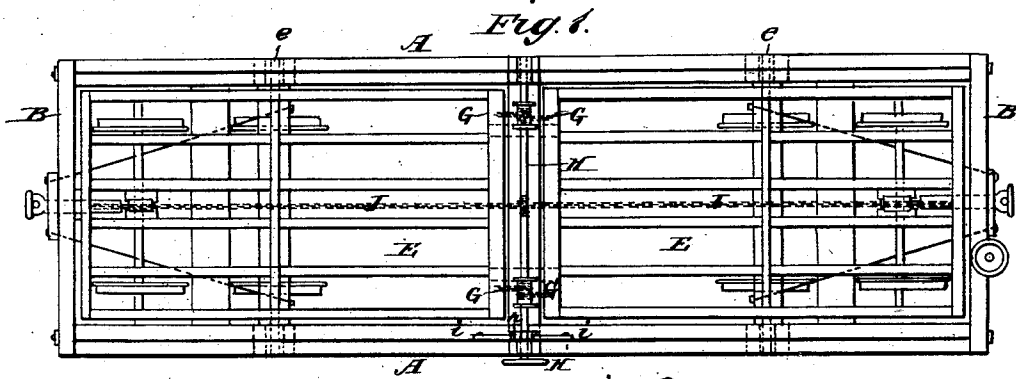

WITNESSES:

*Francis McArdle.*  
*C. Sedgwick*

INVENTOR:

*J. T. Crowther*  
BY *Mum & Co.*

ATTORNEYS.

# UNITED STATES PATENT OFFICE.

JOHN T. CROWTHER, OF CARBONDALE, ILLINOIS.

## DUMPING-CAR.

SPECIFICATION forming part of Letters Patent No. 244,795, dated July 26, 1881.

Application filed April 26, 1881. (No model.)

To all whom it may concern:

Be it known that I, JOHN T. CROWTHER, of Carbondale, in the county of Jackson and State of Illinois, have invented a new and useful Improvement in Dumping-Cars, of which the following is a specification.

My invention relates to a car which is more particularly intended to run upon rails, and it may be used in building railways, or for carrying ore or coal at mines, or for loading or unloading grain, and for various other purposes.

The invention consists in combining racks and pinions with the sections of a dumping-car, as hereinafter described.

In the accompanying drawings, Figure 1 is a top view of a car constructed according to my invention when made in one form. Fig. 2 is a side view of the same. Fig. 3 is a side view of another form of the invention, and Fig. 4 a detail view of a portion of the same.

The car is supported by a frame-work consisting of side rails, A, end pieces, B, and diagonal side braces, C, which frame-work rests upon trucks D, like an ordinary car.

The car is made in two sections, E E, with their inner ends open and adjacent to each other. Each section is pivoted between the side rails, A, by a shaft, *e*, so as to oscillate in a vertical plane. The shaft *e* is located at a point beyond the longitudinal center of the section, so that the portion of the section between the pivot and the inner end is heavier than the portion between the pivot and the outer end.

To the inner end of each section, when made in the form shown in Fig. 1, is attached the lower end of a chain, G, the upper end of which is attached to a windlass, H, journaled in two

posts at the sides of the car, midway of its length. The windlass is provided with a ratchet, *h*, and pawls *i*.

To the outer ends of the sections are attached chains J, having their inner ends attached to the windlass.

When the sections are raised to a level with each other they are held in place by buttons L on the under side of the frame, together with the chains and the windlass and its ratchet and pawls.

When the load is to be deposited, the buttons are turned free of the sections, and the pawls are raised free of the ratchet, so as to allow the windlass to turn, whereupon the weight of the inner ends of the sections cause them to drop to the positions shown in dotted lines, so as to deposit the load beneath the center of the car, after which the sections are raised to the proper level by means of the windlass and chains, and secured by the buttons, as above described.

When the car is made in the form shown in Figs. 3 and 4, instead of the windlass and chains, I employ racks M on the inner ends of the sections engaging with pinions P, worked by a hand-wheel, Q, on a shaft journaled in the frame-work.

Having thus fully described my invention, I claim as new and desire to secure by Letters Patent—

The combination, with the sections E E, of the racks M and pinions P, substantially as and for the purpose herein described.

JOHN T. CROWTHER.

Witnesses:

EDWIN HEWITT,  
GEO. G. STOCK.