

(19)
(12)

(KR)
(A)

(51) 。 Int. Cl.7
G01B 11/06

(11)
(43)

2003-0054157
2003 07 02

(21) 10-2001-0084276
(22) 2001 12 24

(71) () 2 275 LG

(72) 383-5305

(74)
:

(54)

1 ; 1 1 , 1 ; 1 가
1 1 ; 가 2 2 ; 1 2 2
1 ; 2 ; 가 2 2 ; 1 2
2 ; 1 1 ; 1 2 ; 1 2
가 . ,

2

1 ,
2 ,
3 2 ,
4 5 .

(19) 가 2 (10) (21), (31), (34) (31) (32) , (17), 1 가

, , .

, 1 2 ; 1 가 1 ; 1
1 2 ; 1 2
1 2 가 2 ; 1 ;
1 가 2 1 ; 2 ; 가 2
1 ; 1 2 ; 1 1 ; 1 2
; ; 1 2 ; 1 2

, 1 2 .
, 1 2 1 2

2 , 3 2

(11) , (13)가 (11) (11) (13)
(10) (17)가 가 (13) (17) (11) (19)
(17) 가 2 (21) , 1 (13)
2 (21) (11) (13) (10) (10)
가

(41) 2 (17) 2 (21) , (21) , 1 (41) , 1
(41) (41) 1 (41) 가 (41) 2 (43) , 1
(45) , 2 (43) (49) (47) , (47)

, 1 (41) 2 (43)

) , (11) (11) (13) (10) (13) (17)
, 2 (21) (41) 2 (43) 1 (41)가 (17)가 , (13) (21)
5) 1 (41) 2 (43) , (47) , (47) (4)

1

2

1

2

1

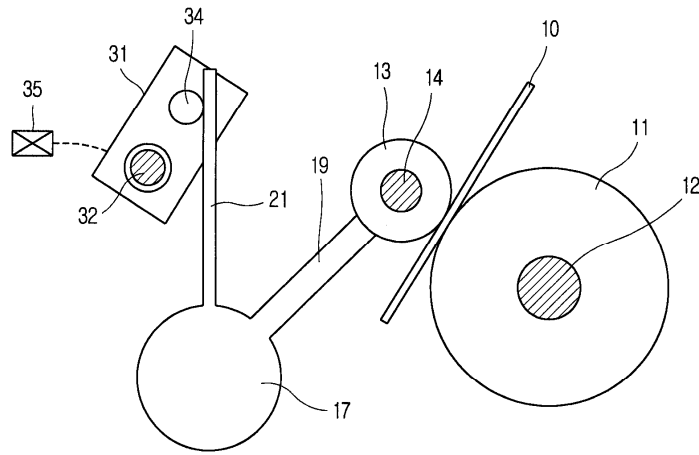

2

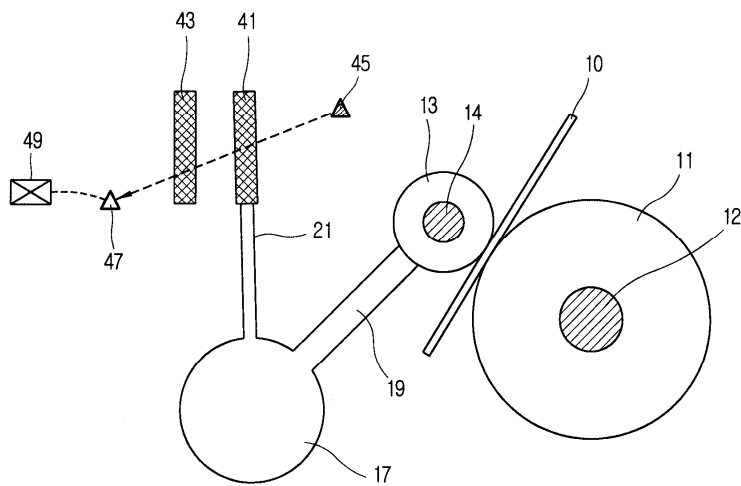

3

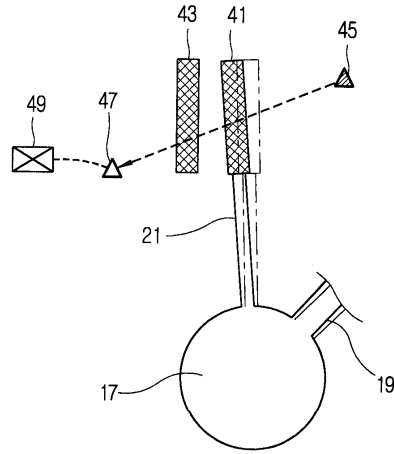

4

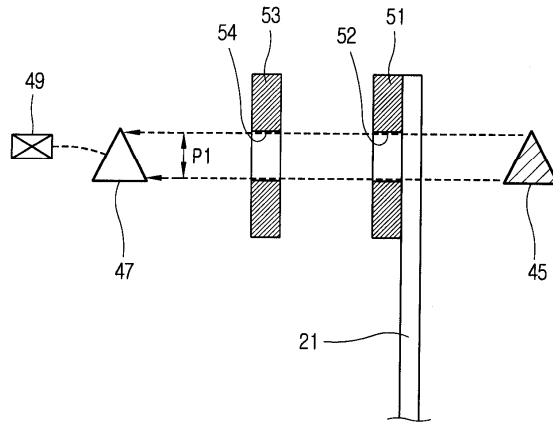

5

