



- (51) International Patent Classification:
F16J 9/26 (2006.01)
- (21) International Application Number:
PCT/US2012/064033
- (22) International Filing Date:
8 November 2012 (08.11.2012)
- (25) Filing Language: English
- (26) Publication Language: English
- (30) Priority Data:
61/557,589 9 November 2011 (09.11.2011) US
- (71) Applicant: **FEDERAL-MOGUL CORPORATION**
[US/US]; 26555 Northwestern Highway, Southfield, MI
48033 (US).
- (72) Inventors: **TOTH, James**; 1030 Wing Drive, Ann Arbor,
MI 48103 (US). **MARSH, Mitchell, T.**; 9991 Kaiser
Road, Saline, MI 48176 (US).
- (74) Agents: **STEARNS, Robert, L.** et al.; Dickinson Wright
PLLC, 2600 W. Big Beaver Road, Suite 300, Troy, MI
48084-3312 (US).

- (81) Designated States (unless otherwise indicated, for every kind of national protection available): AE, AG, AL, AM, AO, AT, AU, AZ, BA, BB, BG, BH, BN, BR, BW, BY, BZ, CA, CH, CL, CN, CO, CR, CU, CZ, DE, DK, DM, DO, DZ, EC, EE, EG, ES, FI, GB, GD, GE, GH, GM, GT, HN, HR, HU, ID, IL, IN, IS, JP, KE, KG, KM, KN, KP, KR, KZ, LA, LC, LK, LR, LS, LT, LU, LY, MA, MD, ME, MG, MK, MN, MW, MX, MY, MZ, NA, NG, NI, NO, NZ, OM, PA, PE, PG, PH, PL, PT, QA, RO, RS, RU, RW, SC, SD, SE, SG, SK, SL, SM, ST, SV, SY, TH, TJ, TM, TN, TR, TT, TZ, UA, UG, US, UZ, VC, VN, ZA, ZM, ZW.
- (84) Designated States (unless otherwise indicated, for every kind of regional protection available): ARIPO (BW, GH, GM, KE, LR, LS, MW, MZ, NA, RW, SD, SL, SZ, TZ, UG, ZM, ZW), Eurasian (AM, AZ, BY, KG, KZ, RU, TJ, TM), European (AL, AT, BE, BG, CH, CY, CZ, DE, DK, EE, ES, FI, FR, GB, GR, HR, HU, IE, IS, IT, LT, LU, LV, MC, MK, MT, NL, NO, PL, PT, RO, RS, SE, SI, SK, SM, TR), OAPI (BF, BJ, CF, CG, CI, CM, GA, GN, GQ, GW, ML, MR, NE, SN, TD, TG).

Published:

— with international search report (Art. 21(3))

(54) Title: PISTON RING WITH A WEAR-RESISTANT COBALT COATING

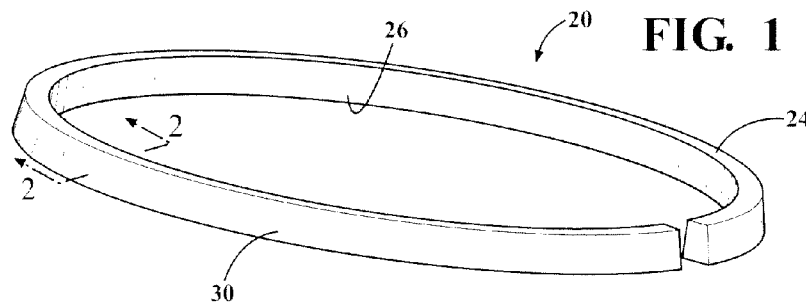

(57) Abstract: A piston ring (20) is provided having a bottom surface (22), a top surface (24), an inner diameter surface (26) and at least one running surface (28). A wear protection coating (30) substantially entirely of cobalt is applied to the at least one running surface to protect the base material of the piston ring. Specifically, during operation of an engine, the more durable cobalt wear resistant coating, not the base material which may be steel or cast iron, is in sliding contact with a cylinder wall. The cobalt coating may be applied through, for example, electrodeposition or plasma spraying.



PISTON RING WITH A WEAR-RESISTANT COBALT COATING

CROSS-REFERENCE TO RELATED APPLICATION

[0001] This patent application claims the benefit of U.S. Provisional Patent Application Serial No. 61/557,589, entitled "Piston Ring with a Wear-Resistant Cobalt Coating", filed on November 9, 2011, the entire disclosure of the application being considered part of the disclosure of this application and hereby incorporated by reference.

BACKGROUND OF THE INVENTION

1. Field of the Invention

[0002] The invention relates to piston rings, and more precisely, to piston rings for internal combustion engines and methods of forming the same.

2. Related Art

[0003] Recent development of internal combustion engines has resulted in increased compression pressures within the combustion chamber of engines and increased engine speeds. As a consequence, the piston rings on the pistons of such engines are rubbed more forcefully against the cylinder walls of the engine, which could result in excessive wear occurring on the exterior of an unprotected piston ring thereby leading to a weaker seal between the piston and the cylinder wall.

[0004] Piston rings for internal combustion engines are typically formed of cast iron or steel materials. One process for reinforcing a cast iron or steel ring is to apply a layer of pure chromium around at least the outer diameter surface of the piston ring. This is advantageous because the chromium directly engages the cylinder wall and protects the cast iron or steel from rubbing or sliding contact with the cylinder wall. Another known process is to apply a layer of less than 70 wt. % cobalt and the remainder of chromium onto the outer diameter surface of piston rings. In such coatings, the chromium provides the primary wear protection, and the cobalt acts as a binder for the chromium.

SUMMARY OF THE INVENTION

[0005] According to one aspect of the invention, a piston ring is provided including a bottom surface, a top surface, an inner diameter surface and at least one running surface. A wear protection coating substantially entirely of cobalt applied to the at least one running surface. The more durable cobalt wear protection surface protects the base material

of the piston ring from sliding contact with a cylinder wall during operation of the engine, thereby improving the life of the piston ring. Additionally, the cobalt wear protection coating has been shown to substantially reduce the amount of oil that is able to flow pass the piston ring as compared to uncoated piston rings or piston rings with other types of coatings. As such, the piston ring constructed according to this aspect of the invention provides improved performance as compared to other known piston rings.

[0006] Another aspect of the present invention is a method of making a piston ring. The method includes the step of preparing a piston ring having a bottom surface, a top surface, an inner diameter surface and at least one running surface. The method proceeds with the step of applying a coating substantially entirely of cobalt onto the at least one running surface of the piston ring. The cobalt wear protection coating may be applied, for example, through electrodeposition or through plasma spraying. Either of these processes is not costly, and therefore, the improved performance of the cobalt wear protection coating is gained cost effectively.

BRIEF DESCRIPTION OF THE DRAWINGS

[0007] These and other features and advantages of the present invention will be readily appreciated, as the same becomes better understood by reference to the following detailed description when considered in connection with the accompanying drawings wherein:

[0008] Figure 1 is a perspective view of a first exemplary piston ring;

[0009] Figure 2 is a cross-sectional view of the first exemplary piston ring taken along line 2-2 of Figure 1;

[0010] Figure 3 is a cross-sectional view of a second exemplary piston ring;

[0011] Figures 4 a-d are enlarged cross-sectional views of the second exemplary piston ring taken along the top side, left side, right side and bottom side respectively; and

[0012] Figures 5 is an enlarged cross-sectional view of a test sample taken of the coating on the second exemplary piston ring.

DETAILED DESCRIPTION OF THE ENABLING EMBODIMENTS

[0013] Referring to the Figures, wherein like numerals indicate corresponding parts throughout the several views, a first exemplary embodiment of a piston ring **20** constructed according to an aspect of the present invention is generally shown in Figure 1.

As shown, the exemplary piston ring **20** has a bottom surface **22**, a top surface **24**, an inner diameter surface **26** and an outer diameter surface (hereinafter referred to as a “running surface **28**”). The base material of the piston ring **20** is preferably steel or cast iron but any other suitable material may be employed, and the piston ring **20** is preferably shaped through machining but may be shaped through any suitable process. As with conventional piston rings, when properly installed on a piston (not shown) within a cylinder bore (not shown) of an internal combustion engine (not shown), the inner diameter surface **26** of the piston ring **20** seals against a groove in the piston, and the running **28** slidably contacts an inner surface of the cylinder wall, thus providing a gas-tight seal between the piston and the cylinder wall. The exemplary piston ring **20** is a compression ring with a taper faced shape, i.e. the outer diameter surface **28** is tapered. However, it should be appreciated that the piston ring **20** could be a scraper ring, an oil control ring or any desirable type of piston ring and could have a range of different shapes.

[0014] The first exemplary piston ring **20** additionally includes a wear protection coating **30** that is substantially entirely of cobalt and is disposed along substantially only along the running surface **28** for protecting the base material of the piston ring **20** during operation of the engine. The cobalt coating **30** is disposed along the entire circumference of the piston ring **20** to protect the base material of the piston ring **20** from the cylinder wall. As such, the life of the piston ring **20** is increased because it is the more durable cobalt coating **30** which is in rubbing or sliding contact with the cylinder wall during operation of the engine rather than the base material of the piston ring **20**. Testing of the first exemplary embodiment of the piston ring **20** in an engine has resulted in an unexpectedly low oil consumption rate of less than 0.02 ounces of oil per hour, which is substantially lower than comparable uncoated piston rings or piston rings with other coatings.

[0015] Because the cobalt coating **30** is disposed substantially only along the running face **28**, the material costs of the cobalt coating **30** are minimized. Additionally, only locating the cobalt coating **30** along the running surface **28** may allow for certain manufacturing advantages because it may be applied to many piston rings **20** simultaneously by stacking the piston rings **20** on top of one another and electroplating or spraying their running faces **28** all at once.

[0016] The cobalt coating **30** is preferably substantially of pure cobalt and preferably has a generally uniform thickness of between eight and twelve microns (8-12 μm) and is most preferably approximately 10 microns (10 μm). Testing data of engines with cobalt coated piston rings **20** with a 10 μm thick coating **30** have yielded extremely low wear

and oil consumption rates. However, it should be appreciated that the cobalt coating **30** could have any desirable thickness.

[0017] A second exemplary piston ring **120** constructed according to this aspect of the present invention is generally shown in Figures 3-8 with the same reference numerals, offset by a factor of 100, being used to identify similar features as discussed above. The second exemplary embodiment of the piston ring **120** is distinguished from the first exemplary embodiment discussed above by the cobalt coating **130** being applied to the bottom, top and inner diameter surfaces **122, 124, 126** in addition to the running surface **128**.

[0018] After the first exemplary piston ring is shaped, to give the base material has a predetermined microstructure. After the heat treating process is completed, the piston ring **20** is coated with a wear protection coating **30** that is substantially entirely of cobalt along substantially only its running surface **28**.

[0019] Another aspect of the present invention provides for a method of making a piston ring **20**, such as the first exemplary embodiment discussed above. The method starts with the step of preparing a piston ring **20** having a bottom surface **22**, a top surface **24**, an inner diameter surface **26** and at least one running surface **28**. The piston ring **20** could be, for example, a compression ring, a scraper ring or an oil control ring, could have any desirable shape and could be shaped through any suitable shaping process.

[0020] The method continues with the step of applying a wear protection coating **30** substantially entirely of cobalt onto the at least one running surface **28** of the piston ring **20**. The method may additionally including the step of applying the coating **30** onto one or more of the bottom, top and inner diameter surfaces **22, 24, 26** in addition to the running surface **28**. In one embodiment, the applying step is further defined as electrodepositing the coating **30** onto the piston ring **20**. During the electroplating process, the base material of the piston ring **20** is negatively charged and submerged in a positively charged cobalt electrolyte which causes a bond to form between the cobalt and the base material. This electrodepositing process has been found to provide a coating **30** with a sufficiently uniform thickness across the area to be coated. According to another embodiment, the applying step is further defined as plasma spraying the coating **30** onto the piston ring **20**.

[0021] Obviously, many modifications and variations of the present invention are possible in light of the above teachings and may be practiced otherwise than as specifically described while within the scope of the appended claims.

CLAIMS

What is claimed is:

1. A piston ring, comprising:
a bottom surface, a top surface, an inner diameter surface and at least one running surface; and
a wear protection coating substantially entirely of cobalt applied to said at least one running surface.
2. The piston ring as set forth in claim 1 wherein said wear protection coating is applied to substantially only said at least one running surface.
3. The piston ring as set forth in claim 1 wherein said wear protection surface is applied to at least one of said bottom, top and inner diameter surfaces in addition to said running surface.
4. The piston ring as set forth in claim 3 wherein said wear protection surface is applied to all of said bottom, top, inner diameter and running surfaces.
5. The piston ring as set forth in claim 1 wherein said wear protection coating is pure cobalt.
6. The piston ring as set forth in claim 1 wherein said wear protection coating has a thickness of between 8 and 12 microns.
7. The piston ring as set forth in claim 6 wherein said wear protection coating has a thickness of approximately 10 microns.
8. A method of making a piston ring, comprising the steps of:
preparing a piston ring having a bottom surface, a top surface, an inner diameter surface and at least one running surface; and
applying a wear protection coating substantially entirely of cobalt onto the at least one running surface of the piston ring.

9 The method as set forth in claim 8 wherein said step of applying a coating is further defined as electrodepositing a coating substantially entirely of cobalt onto the at least one running surface of the piston ring.

10. The method as set forth in claim 8 further including the step of applying the coating onto at least one of the bottom, top and inner diameter surfaces in addition to the at least one running surface.

11. The method as set forth in claim 10 further including the step of applying the coating onto all of the bottom, top, inner diameter and running surfaces.

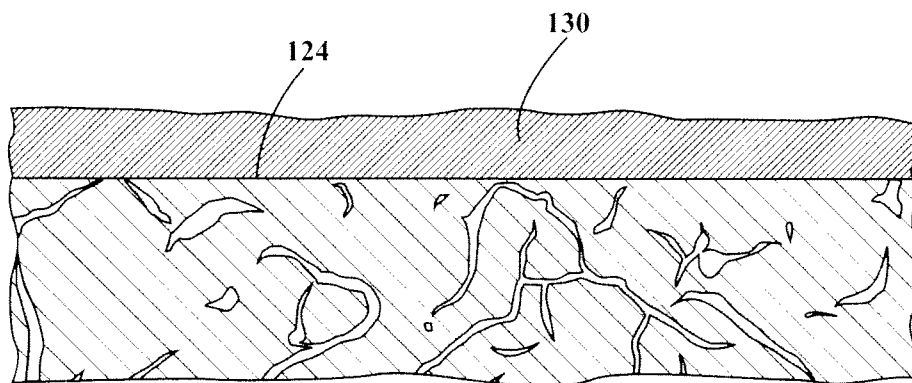
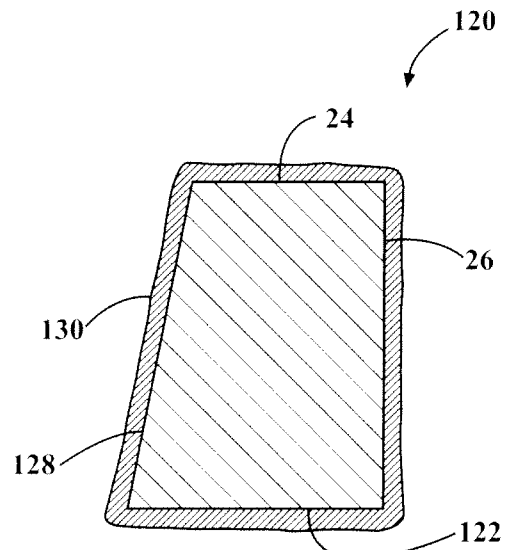
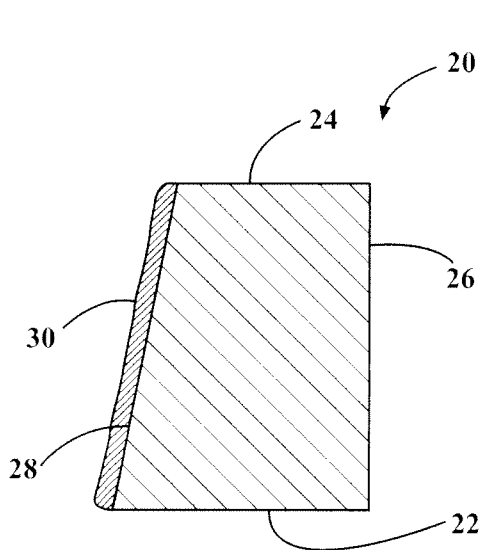
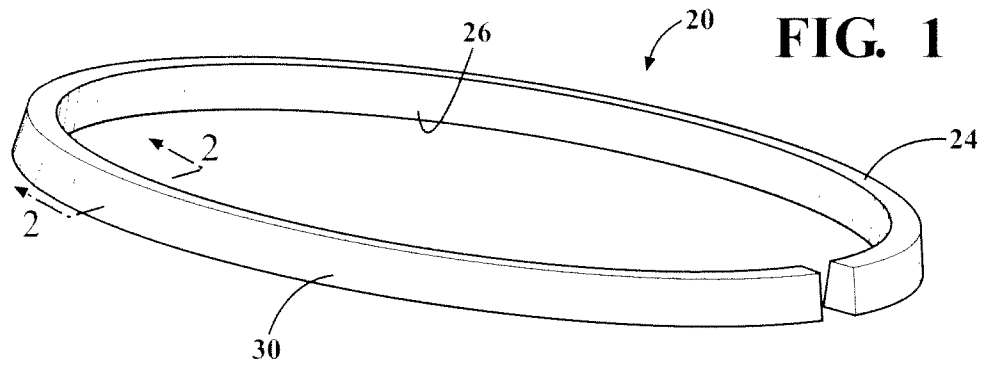

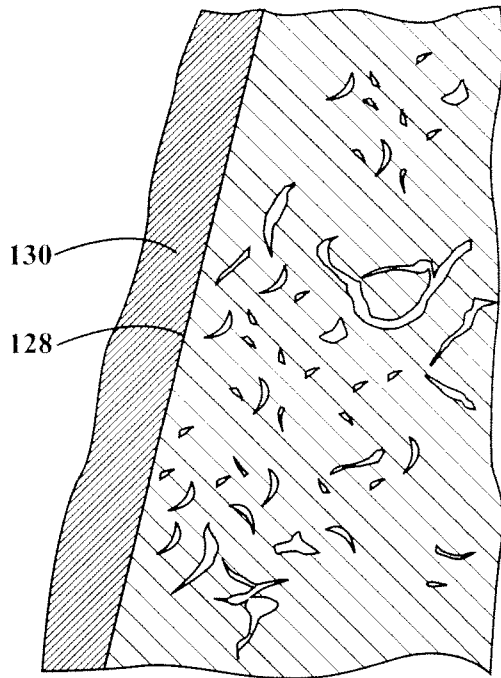

FIG. 4B

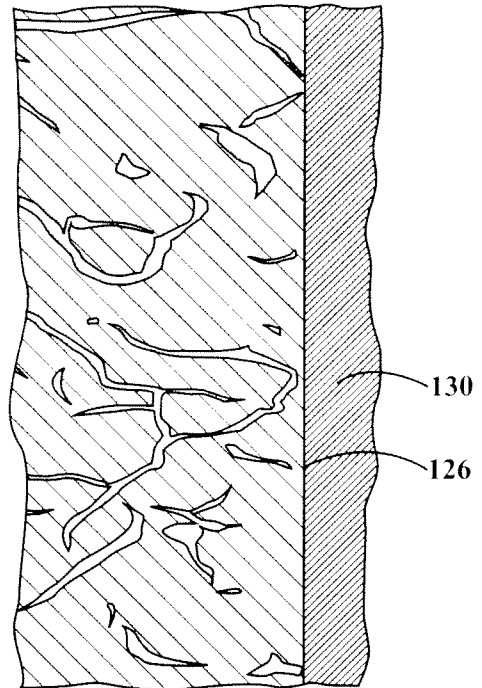

FIG. 4C

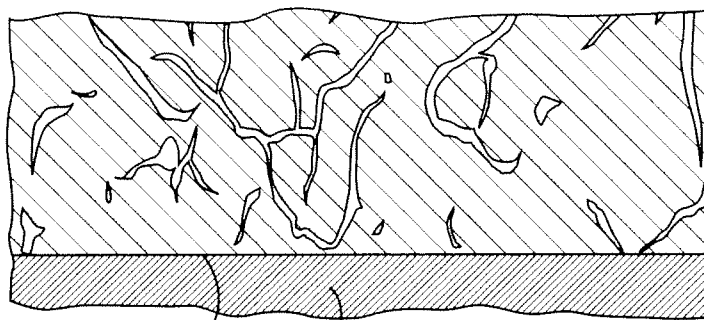

FIG. 4D

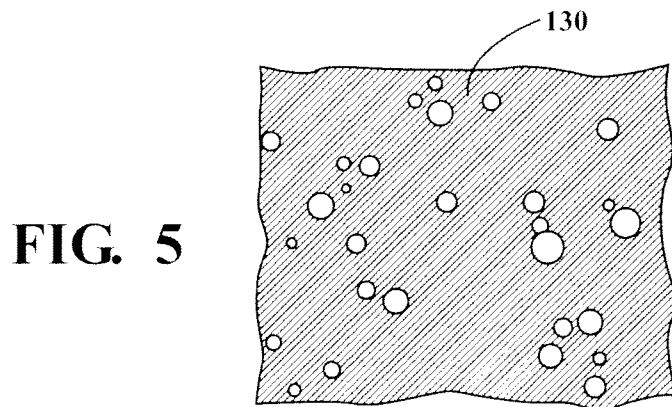

FIG. 5

INTERNATIONAL SEARCH REPORT

International application No
PCT/US2012/064033

A. CLASSIFICATION OF SUBJECT MATTER
INV. F16J9/26
ADD.

According to International Patent Classification (IPC) or to both national classification and IPC

B. FIELDS SEARCHED
Minimum documentation searched (classification system followed by classification symbols)
F16J

Documentation searched other than minimum documentation to the extent that such documents are included in the fields searched

Electronic data base consulted during the international search (name of data base and, where practicable, search terms used)
EPO-Internal, WPI Data

C. DOCUMENTS CONSIDERED TO BE RELEVANT

| Category* | Citation of document, with indication, where appropriate, of the relevant passages | Relevant to claim No. |
|-----------|---|-----------------------|
| X | US 2009/174150 A1 (SMITH THOMAS [US] ET AL) 9 July 2009 (2009-07-09) | 1-4,6-11 |
| A | paragraph [0032]; figure 1 | 5 |
| X | DE 34 44 456 C1 (MAN B & W DIESEL GMBH) 19 December 1985 (1985-12-19) | 1-4,6-11 |
| A | claim 1 | 5 |
| X | DE 38 02 920 C1 (GOETZE) 3 May 1989 (1989-05-03) | 1-3,8-10 |
| A | column 1, line 43 - line 49 | 5 |
| A | GB 2 193 786 A (HONDA MOTOR CO LTD HONDA MOTOR CO LTD [JP]) 17 February 1988 (1988-02-17) | 1-11 |
| | the whole document | |

Further documents are listed in the continuation of Box C.

See patent family annex.

* Special categories of cited documents :

- "A" document defining the general state of the art which is not considered to be of particular relevance
- "E" earlier application or patent but published on or after the international filing date
- "L" document which may throw doubts on priority claim(s) or which is cited to establish the publication date of another citation or other special reason (as specified)
- "O" document referring to an oral disclosure, use, exhibition or other means
- "P" document published prior to the international filing date but later than the priority date claimed

- "T" later document published after the international filing date or priority date and not in conflict with the application but cited to understand the principle or theory underlying the invention
- "X" document of particular relevance; the claimed invention cannot be considered novel or cannot be considered to involve an inventive step when the document is taken alone
- "Y" document of particular relevance; the claimed invention cannot be considered to involve an inventive step when the document is combined with one or more other such documents, such combination being obvious to a person skilled in the art
- "&" document member of the same patent family

Date of the actual completion of the international search

23 January 2013

Date of mailing of the international search report

13/02/2013

Name and mailing address of the ISA/

European Patent Office, P.B. 5818 Patentlaan 2
NL - 2280 HV Rijswijk
Tel. (+31-70) 340-2040,
Fax: (+31-70) 340-3016

Authorized officer

Revilla, Xavier

INTERNATIONAL SEARCH REPORT

Information on patent family members

International application No

PCT/US2012/064033

| Patent document cited in search report | Publication date | Patent family member(s) | Publication date | |
|--|------------------|-------------------------|------------------|------------|
| US 2009174150 | A1 | 09-07-2009 | CN 101910687 A | 08-12-2010 |
| | | | EP 2240711 A1 | 20-10-2010 |
| | | | JP 2011509386 A | 24-03-2011 |
| | | | KR 20100105842 A | 30-09-2010 |
| | | | US 2009174150 A1 | 09-07-2009 |
| | | | WO 2009088741 A1 | 16-07-2009 |
| ----- | | | | |
| DE 3444456 | C1 | 19-12-1985 | NONE | |
| ----- | | | | |
| DE 3802920 | C1 | 03-05-1989 | DE 3802920 C1 | 03-05-1989 |
| | | | EP 0326658 A1 | 09-08-1989 |
| | | | JP 1222040 A | 05-09-1989 |
| ----- | | | | |
| GB 2193786 | A | 17-02-1988 | CA 1328385 C | 12-04-1994 |
| | | | DE 3725495 A1 | 04-02-1988 |
| | | | FR 2602272 A1 | 05-02-1988 |
| | | | GB 2193786 A | 17-02-1988 |
| | | | US 4817578 A | 04-04-1989 |
| ----- | | | | |