

(No Model.)

2 Sheets—Sheet 1.

E. R. JOHNSON.
 GRAMOPHONE AND ACTUATING DEVICE THEREFOR.
 No. 601,198. Patented Mar. 22, 1898.

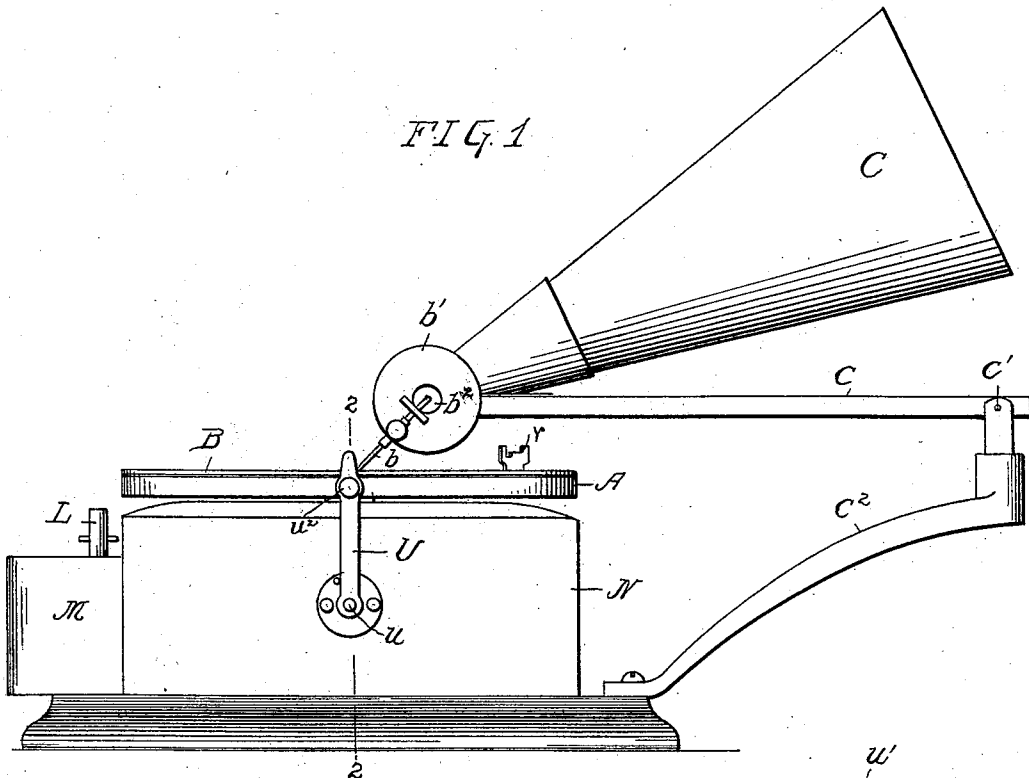

FIG. 2

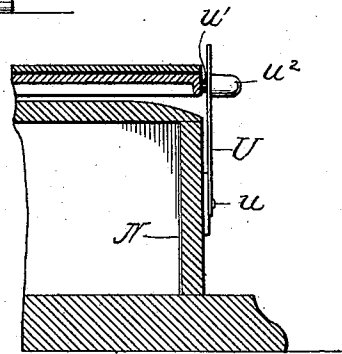
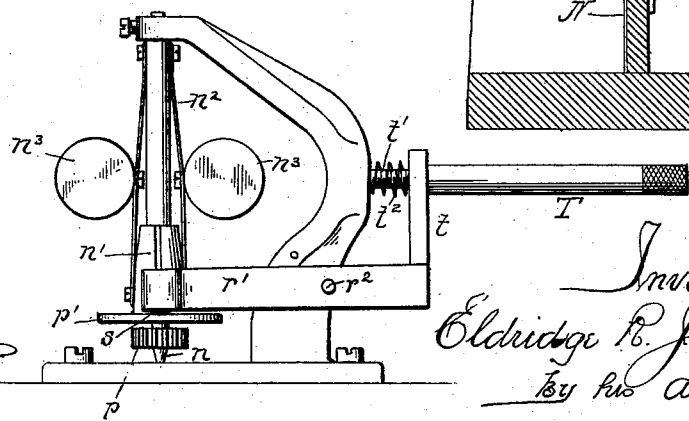

FIG. 5



Witnesses:
Wm. C. Carter
Burr Peoples

Inventor:
Eldridge B. Johnson
 by his Attorney,
1 Stone Street.

E. R. JOHNSON.

GRAMOPHONE AND ACTUATING DEVICE THEREFOR.

No. 601,198.

Patented Mar. 22, 1898.

FIG. 3

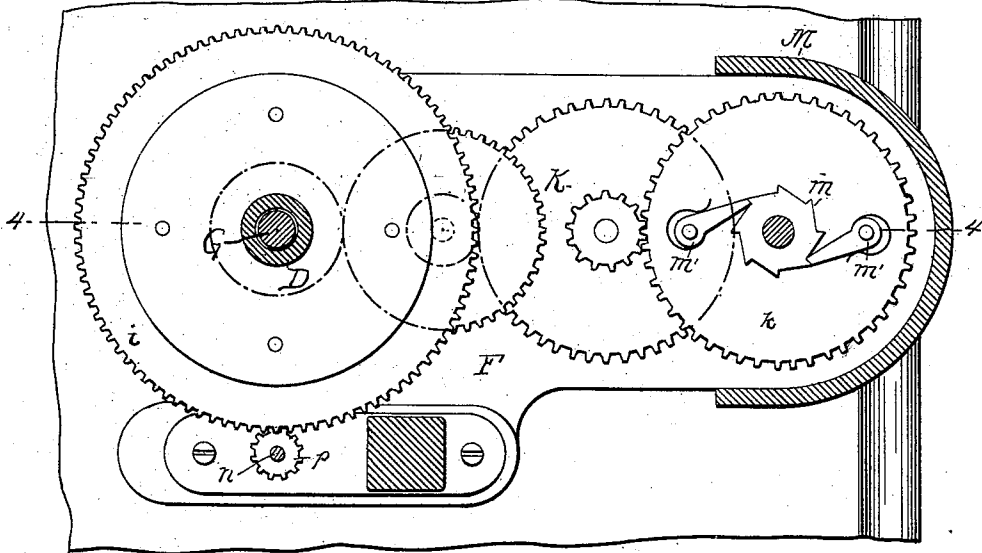
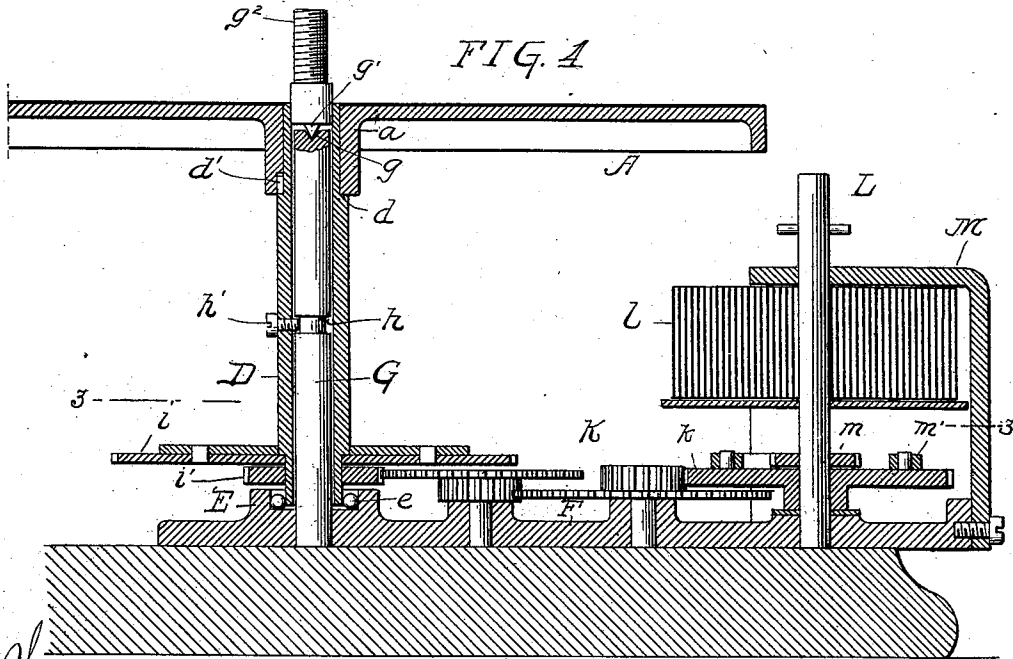

FIG. 1



Witnesses:
John E. Parker
Bliss Hooper

Inventor:
Eldridge R. Johnson
 by his Attorney,
James Pettit

UNITED STATES PATENT OFFICE.

ELDRIDGE R. JOHNSON, OF CAMDEN, NEW JERSEY.

GRAMOPHONE AND ACTUATING DEVICE THEREFOR.

SPECIFICATION forming part of Letters Patent No. 601,198, dated March 22, 1898.

Application filed August 19, 1897. Serial No. 648,751. (No model.)

To all whom it may concern:

Be it known that I, ELDRIDGE R. JOHNSON, a citizen of the United States, and a resident of Camden, State of New Jersey, have invented certain new and useful Improvements in Gramophones and Actuating Devices Therefor, of which the following is a full, clear, and exact description, reference being had to the accompanying drawings, forming part of this specification.

My invention relates to certain improvements in gramophones and sound recording and reproducing machines of like nature in which a record disk or cylinder is propelled by power, and has for its principal object to provide an improved form of mechanism for effecting the rotation of the disk under the reproducing-stylus.

My invention further comprises certain improvements in the mechanism for supporting and rotating the record-disk and for adjusting and regulating the rotations of the latter, as more fully set forth hereinafter.

In the accompanying drawings, Figure 1 is an elevation of a gramophone arranged and constructed in accordance with my invention. Fig. 2 is a sectional elevation of a portion of the same on the line 2 2, Fig. 1. Fig. 3 is a sectional plan view of a portion of the driving mechanism on the line 3 3, Fig. 4. Fig. 4 is a sectional elevation of the same on the line 4 4, Fig. 3; and Fig. 5 is an elevation of the governor for regulating the speed of rotation of the table, on which the record-disk is supported.

Referring to the drawings, A represents a circular table or platform, on which is placed a record-disk B, in which has been formed a continuous record-groove by a needle or stylus and a diaphragm vibrated by sound-waves in the usual manner. The table and disk are rotated under a stylus *b*, secured to a casing *b'* and connected at one end to a suitable diaphragm *b²*, from which leads a trumpet or earpiece C. This mechanism is carried by an arm *c*, pivoted at *c'* to a support *c²* and so arranged that it may be free to travel during the rotation of the disk.

The table A has a central hub *a*, which rests upon a shoulder *d*, formed near the upper end of a sleeve D, and is keyed to said sleeve by a pin *d'*. The lower end of the sleeve is of

somewhat smaller diameter and preferably rests within a cup E, in which are placed a number of balls *e*, acting to keep the sleeve in a central position. It is clear, however, that the sleeve can be maintained in a central position by other means—such, for instance, as by the use of an ordinary metal bushing or collar adjusted around the lower end of the post and within the sleeve.

From the base F of the operating mechanism extends a vertical post G, having in its upper end a conical depression or recess *g* for the reception of a conical pin *g'*, secured or formed integral with a threaded post *g²*, keyed or otherwise secured to the sleeve D and arranged to rotate with the sleeve during the operation of the machine. The post G is provided about midway of its length with an annular groove *h*, into which extends a set-screw *h'*, carried by the sleeve D and adapted to prevent any excessive vertical movement of the sleeve.

To the sleeve D are secured a gear-wheel *i* and a pinion *i'*, which latter is driven by a train of gearing K from a gear-wheel *k*, carried by a winding-post L, to which latter is secured one end of a spiral spring *l*. The opposite end of the spring *l* is secured to a semicircular casing M, arranged at one side of the box or casing N, and the connection between the winding-post and the gear-wheel *k* is through a ratchet-wheel *m*, carried by the post, and pawls *m'*, carried by the gear-wheel and arranged to make contact with the teeth of the ratchet-wheel *m*.

The casing M serves to keep the spiral spring within a comparatively small space without materially interfering with the winding of its coils, and at the same time forms a bearing or support for the upper end of the winding-post L.

At one side of the train of gearing is arranged a governor, constructed in the manner shown in Fig. 5 and comprising a vertical shaft *n*, having upper and lower bearings and provided with a sleeve *n'*, to which are secured the lower ends of springs *n²*, carrying weights or balls *n³*. The shaft *n* is provided with a pinion *p*, arranged to intermesh with the gear-wheel *i*, and immediately above the pinion is a disk *p'*, secured to or formed integral with the sleeve *n'*, and so arranged

that as the speed of rotation increases the disk will be vertically raised and make contact with an arm or arms r' , pivoted at r^2 to the governor-standard, so that an excessive speed of rotation will be checked by the frictional contact between the upper face of the disk and rubber bearing-blocks s , carried by the arms r' . To the outer ends of the bars r' is secured an arm t , having an opening for the passage of a rod T, threaded at t' and screwing into a threaded opening in the governor-standard, so that by turning the rod T the arms r' may be moved to a greater or less distance from the disk p' and the rotations of the governor be checked at any desired point. To oppose the adjustment of the arms r' , a coiled spring t^2 is placed around the threaded end t' of the rod T at a point between the governor-standard and the arm t .

At one side of the box or casing N is secured an arm U, pivoted at its lower end to a plate u , and at its upper end being provided with a small block u' , of rubber or similar material, adapted to make contact with the periphery of the supporting-table A. The arm U has an operating handle or knob u^2 , by which it may be moved into contact with the edge of the disk when it is desired to check the speed of the latter.

At one side of the casing N is secured a rest or stop v for the reception and support of the diaphragm-case b' when the latter is moved on its supporting-lever c during the removal of a new record-disk or at times when the machine is out of operation.

Having thus described my invention, what I claim, and desire to secure by Letters Patent, is—

1. The combination of the rotatable table, a driving-sleeve for said table, mechanism for rotating said sleeve, a stationary supporting-post within said sleeve and a step-supporting pin between the table and the top of said post.

2. The combination of the rotatable table, a driving-sleeve therefor, means for supporting said sleeve, a roller-bearing acting to maintain the sleeve in a central position, and means for rotating said sleeve.

3. The combination of the rotatable table, a driving-sleeve operatively connected thereto, a supporting-post, means for centrally supporting said sleeve on said post, and mechanism for rotating said sleeve, substantially as specified.

4. The combination of the supporting-post having a recessed upper end, a rotatable table, a driving-sleeve operatively connected thereto, a conical pin carried by the sleeve

and adapted to fit within the recessed end of the post, and a ball-bearing adapted to keep the lower end of the sleeve in a central position, substantially as specified.

5. The combination of the rotatable table, a driving-spring, gearing operatively connecting the spring and table, a winding-post carrying said spring, and a casing surrounding said spring and forming a bearing for said post.

6. The combination of the rotatable table, a driving-sleeve therefor, means for supporting said sleeve, a roller-bearing acting to maintain the sleeve in a central position, a driving-gear secured to said sleeve at or near the lower end thereof, and mechanism for rotating said driving-gear.

7. In a motor the combination of a driving-sleeve, a supporting-post extending partly within the sleeve and having a bearing-surface for contact therewith, means for maintaining the sleeve in a central position, a driving-gear secured to said sleeve at or near the lower end thereof, and means for rotating said driving-gear.

8. The combination of the rotatable table, a clockwork mechanism for rotating the same, a governing device for regulating the speed of such mechanism, a frame carrying said governing device, said frame being adjustable as a whole, toward and from the clockwork mechanism.

9. The combination of the rotatable table, a motor for driving the same, a governing device, an adjustable frame carrying the same, gears on the motor and on the governor, said governor-frame being adjustable toward and from the motor mechanism to regulate the degree of intermesh of gears, substantially as specified.

10. The combination of the rotatable table, a motor for driving the same, a frame adjustable as a whole toward and from the motor mechanism, and a governor having its central or main shaft supported at opposite ends in bearings in said frame.

11. The combination of the rotatable table, a motor for driving the same, a governor having centrifugally-operated arms, a friction-disk movable by said arms, and a regulating-lever having arms or fingers adapted to make contact with said disk, and means for adjusting said arms, substantially as specified.

In witness whereof I have hereunto set my hand this 18th day of August, A. D. 1897.

ELDRIDGE R. JOHNSON.

Witnesses:

W. S. FURST,
JNO. E. PARKER.