

Feb. 7, 1933.

C. F. DILKS

1,896,073

ACOUSTIC DIAPHRAGM

Filed Oct. 7, 1930

2 Sheets-Sheet 1

Fig. 1.

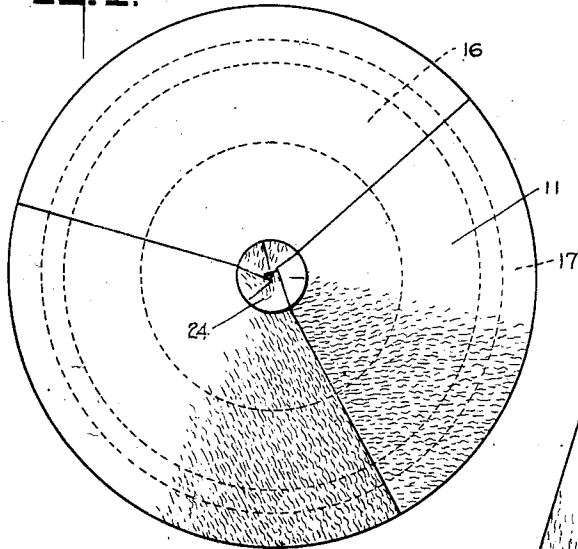

Fig. 3.

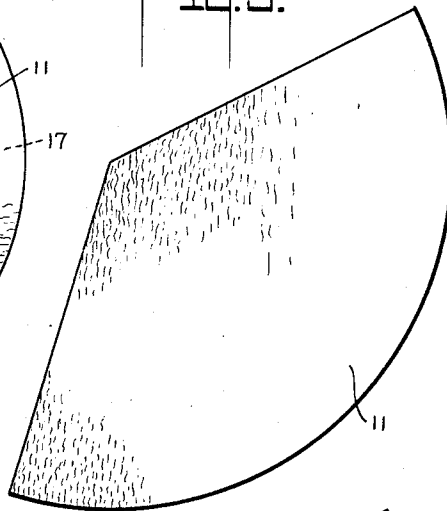

Fig. 2.

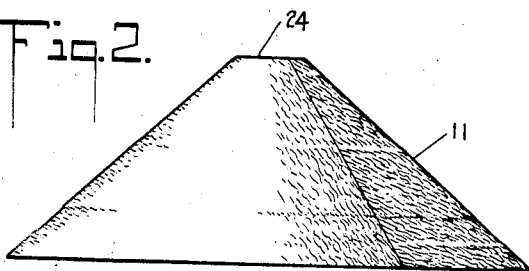

Fig. 4.

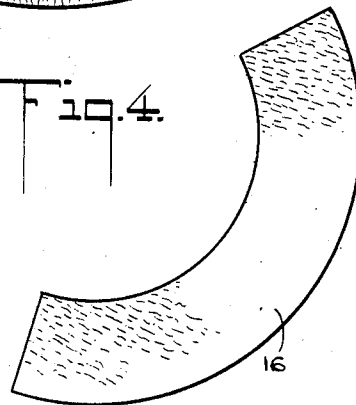
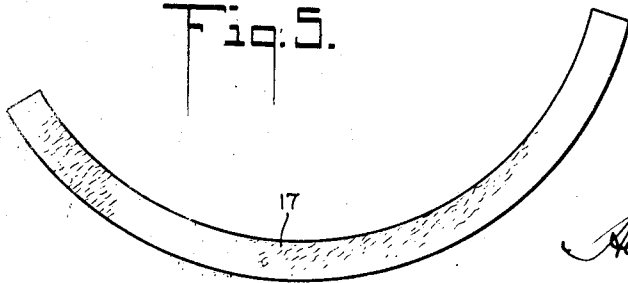

Fig. 5.



INVENTOR,
Charles F. Dilks
BY
Henry J. Lucke
ATTORNEY

Feb. 7, 1933.

C. F. DILKS

1,896,073

ACOUSTIC DIAPHRAGM

Filed Oct. 7, 1930

2 Sheets-Sheet 2

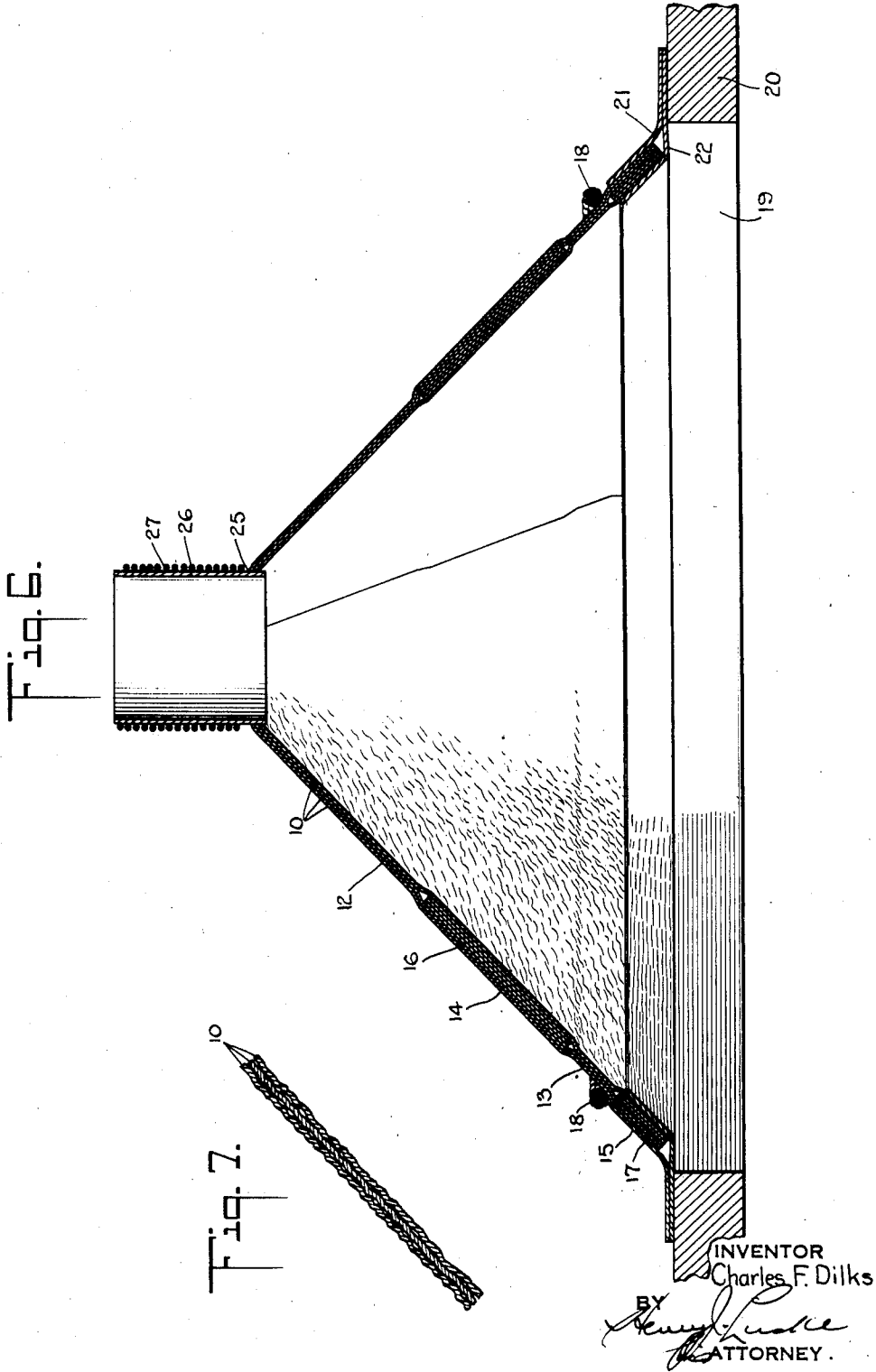

UNITED STATES PATENT OFFICE

CHARLES F. DILKS, OF LONG ISLAND CITY, NEW YORK

ACOUSTIC DIAPHRAGM

Application filed October 7, 1930. Serial No. 486,989.

My invention relates to acoustic diaphragms of the general class including cone or other diaphragms of relatively large area, employed in radio, public address sound reproducers, and the like.

Principal objects and advantages of the invention are:

To provide a diaphragm which gives exceptionally faithful sound and tone reproduction with capability of large volume or sound intensity in proportion to its area when the input energy is adjusted for such large volume, without undesirable tone distortions including those of the character usually called "blasting", and effect equally faithful reproduction in lower ranges of volume; to so construct or arrange the diaphragm that different of its portions or zones respond most readily to different ranges of sound frequencies or frequency; and also to in effect damp or reduce the relative intensity of frequencies of certain ranges, such for example, as those corresponding to the undesired or discordant sixth harmonic.

A further object is to realize these and other objects or advantages in a diaphragm composed of inexpensive material which is at the same time of a character which has a low inherent resonance but is readily responsive to applied vibrations and produces high acoustic pressure in proportion to input energy.

To realize the stated and other purposes and advantages, diaphragms embodying the invention consist, as briefly described, of a plurality of laminæ or sheets, or at least certain zones or areas include a plurality of laminæ, such layers or laminations consisting preferably of material of a generally fibrous character such as, in a preferred example, paper of relatively soft composition or texture and of irregular or crepe-like formation, having relatively rough or "crinkly" surfaces. A good example of a preferred material available for this purpose is paper of the character used for paper towels. In order to provide sufficient structural strength and stiffness throughout, the diaphragm preferably includes throughout its

area at least two or more layers of the sheet material, and these layers or laminæ are secured together by a suitable adhesive of which tapioca paste is mentioned as a preferred ingredient, for reasons stated hereafter; and certain annular areas or zones of the diaphragms are of increased thickness, stiffness and/or weight by inclusion therein of one or more additional layers or laminæ of the same material, these zones being located preferably, one at or about the periphery of the diaphragm and another in an intermediate position between the apex and the periphery but relatively near the latter, to include and relatively damp intermediate audio-frequencies and the undesired sixth harmonic.

The stated thickness variation also provides for faithful reproduction of tones of different frequency ranges with proper relative intensities. Thus, in one preferred embodiment of my invention, I provide a relatively wide zone extending outward from the apex, of minimum thickness, which has a natural vibration frequency corresponding to the high audio-frequencies; the intermediate thickened zone has a natural frequency corresponding to intermediate audio-frequencies, and the peripheral thickened zone responds naturally to the lower frequencies without rattling, blasting, or "hollow" tone effects.

As otherwise stated, the diaphragm, which is thrown into loop or segment and node formations corresponding to vibratory movements of a musical string, and extending in all directions, axially as well as circumferentially of the diaphragm, has its thickness in different zones so proportioned that each zone favors or tends to increase the amplitude of the loops or segments corresponding to a certain frequency range and the intermediate thickened zone includes the nodal points corresponding to the undesired sixth harmonic with resulting substantial suppression of that harmonic and elimination of discordant effects produced by it.

The tone quality is further improved in some cases by applying and securing by adhesive a controlling or damping ring in the

nature of a heavy cord, located relatively near the periphery of the cone or adjacent the inward edge of the peripheral thickened zone. The central portion or apex of the cone
 5 may be shaped or conformed in various ways for connection to driving elements of different character, as sufficiently explained below.

Desirably the periphery of the diaphragm or cone is connected to and yieldably supported on an apertured sound board or other
 10 suitable support by annular strips of suitable flexible material, such as leather.

The various paper pieces composing the diaphragm may be shaped in various ways to conveniently provide the multiple layers
 15 and to build up the relatively thickened zones, as also sufficiently explained in detail below.

The characteristics and advantages of the invention are further sufficiently explained in connection with the following detail description of the accompanying drawings, which show representative embodiments. After
 20 considering these examples, skilled persons will understand that many variations may be made without departing from the principles disclosed, and I contemplate the employment of any and all structures that are properly within the scope of the appended claims.

Fig. 1 is an elevation, either front or rear, depending on its position in use, of a diaphragm embodying the invention in one
 30 form.

Fig. 2 is a side elevation.

Fig. 3 is a plan of one form of a paper sheet employed in building up the main diaphragm
 35 structure.

Figs. 4 and 5 show other forms of paper pieces used in the thickened zones.

Fig. 6 is an axial section of Figs. 1 or 2,
 40 enlarged.

Fig. 7 is a sectional detail of a portion of the diaphragm wall, showing particularly in somewhat exaggerated manner for the
 45 sake of clearance, the rough or crepe-like paper preferably employed as the cone body material.

While I have here illustrated only diaphragms of conical forms and such forms are preferred in some cases, the presented principles of construction or arrangement may
 50 also be applied to flat diaphragms.

As above stated the preferred material for this purpose is paper of relatively soft and
 55 rough texture, such as paper toweling, and in order to provide sufficient mechanical strength and stability the diaphragm wall at all points preferably includes a plurality, or as shown, three layers, 10, of this material.

It is impracticable to show the rough or crepe-like character of the material in Fig. 6, but Fig. 7 shows a small portion of one thin part of the diaphragm wall, with the
 60 crinkly or crepe-like surface formations of the layers somewhat exaggerated for explan-

atory purposes. The various layers or laminae are secured together by any suitable cement, but preferably I employ a cement in which tapioca is a principal ingredient, because this material contracts in drying, thus
 70 practically putting the entire diaphragm under a normal tension, increasing its mechanical strength and resistance to injury and at the same time imparting a desired resilience and responsiveness to the impressed vibrations.
 75

In some cases each layer or lamination 10 may be a single sheet properly cut with the edges lapped or abutting and with the edge joints or seams of the different layers in interspaced relation; or, as shown in Fig. 3,
 80 each lamination may consist of a plurality of segments 11 with their edges abutting or overlapping and these segment joints or seams in the different layers may be in interspaced relation.
 85

The entire diaphragm comprises a plurality of zones of different thickness. In the particular example given there are four of these circular zones of which the inner or
 90 upper zone 12 and the outer intermediate zone 13 are of the minimum thickness consisting of the three layers or laminae above referred to, while the intermediate zone 14 and the peripheral zone 15 are of increased
 95 thickness, each consisting, as shown, of six layers or laminae produced in the case of zone 14 by cementing together and between certain of the main layers 10, strips or segments 16, Fig. 4; and in the case of the zone 15 the thickening is obtained by the use of narrower strips or segments 17, Fig. 5.
 100

While the width of these thickened zones and their location with respect to the diaphragm as a whole may be varied substantially, Fig. 6 shows preferred approximate relative dimensions and locations of the thickened zones, the peripheral zone 15 being of moderate width and located directly at the open margin of the cone, while zone 14 is wider and located relatively near but spaced from the peripheral zone, so that the upper thin portion 10 is of a width approximately one-half the surface width of the cone; stiffened zone 14 is wider, approximately one-third of the entire face width, and zones 13 and 15 are narrower than the others.
 110
 115

In some cases vibrations of the outer thin zone 13 are additionally damped by a cord 18 encircling the diaphragm near the inner edge of the outer thickened zone 15, and cemented in position as by the tapioca paste or equivalent above referred to.
 120

The diaphragm may be supported in any suitable way, but preferably in some cases it is supported at the opening 19 of a front plate or board 20 forming a part of the reproducing apparatus as a whole or of its cabinet, by annular leather strips 21 and 22,
 125
 130

of which portions are cemented to the outer zone of the diaphragm at opposite sides thereof, and the other portions are cemented or otherwise secured together and to the front board or baffle board 20, thus providing a definite but flexible support for the periphery of the diaphragm, without impairment of freedom and accuracy of its vibrations.

The form of the center, or apex, of the diaphragm may vary. Thus, in Figs. 1 and 2 the central portion 24 may be flattened and suitable fittings may be secured to it for the connection of a driving pin of any suitable audio amplifier, as well understood in the art; or as shown in Fig. 6, the central portion may be cut away, leaving an aperture 25 in which one end of a sleeve 26 is inserted and secured by cementing. This sleeve may have an actuating coil, usually called a voice coil, of an audio-amplifier of the dynamic type, wound directly on it.

In operation, the inward thin zone 10 of large area being located nearest the apex of the cone, and of relatively small diameter, has a natural vibration frequency corresponding approximately to the audio-vibrations of the higher frequency ranges and these "high" notes are relatively emphasized by the thinness of the diaphragm; the intermediate thickened zone 14 is of dimensions which make it naturally responsive to vibrations of intermediate frequencies but the thickened structure of this zone also has a substantial damping effect preventing excessive relative "loudness" of sounds in this range and also tends to practically suppress the unwanted sixth harmonic. The marginal thickened zone 15 is of dimensions to respond naturally to the lowest notes in the audible register and also by reason of its thickness sufficiently damps these notes so that rattling or blasting are prevented and faithful reproduction is obtained.

The diaphragm as a whole therefore provides exceptionally faithful tone reproduction with large volume or acoustic pressure in proportion to energy applied to it by the driving pin or the like, and it has been demonstrated in practice that the diaphragm gives improved and satisfactory reproduction of the entire audible range including very high and very low notes which are ordinarily "cut off" by diaphragms or other acoustic reproducers heretofore employed.

Preferably, the mass of the diaphragm in general, and of the constituent parts individually, is selected as low as possible, consistent with the desired relative rigidity of structure, the quality of reproduction and permanence of performance, whereby more faithful reproduction of the desirable high frequencies is attained. Also, the voice coil, see 27, Fig. 6, is formed of lowest mass, and the metallic wire may be of aluminum or suitable alloy thereof, and likewise the mass

of its spool is reduced to a minimum, to facilitate the reproduction of the desired high frequencies, in combination with the structure of the diaphragm proper.

Whereas, I have illustrated my invention by specific embodiments thereof, it will be understood that many changes and modifications may be made without departing from the spirit of the invention.

I claim:

1. An acoustic diaphragm composed of a plurality of layers of soft, rough paper, secured together by cement.

2. An acoustic diaphragm composed of a plurality of layers of soft, rough paper, secured together by contractile cement.

3. An acoustic diaphragm composed of a plurality of layers of soft, rough paper, secured together by tapioca cement.

4. An acoustic diaphragm composed of a plurality of layers of crepe-like material connected by cement and having a plurality of annular zones of greater thicknesses, toward the periphery.

5. An acoustic diaphragm composed of a plurality of layers of fibrous material connected by cement and having a plurality of annular zones of different thicknesses, the thickened zones including additional laminae of the same material.

6. An acoustic diaphragm composed of a plurality of layers of fibrous material connected by cement and having a plurality of annular zones of different thicknesses, and a cord-like damping element cemented to the diaphragm relatively near its periphery.

7. An acoustic diaphragm composed of a plurality of layers of fibrous material connected by cement and having a plurality of annular zones of different thicknesses, and a cord-like damping element cemented to the diaphragm relatively near its periphery and adjacent the inner edge of an outer thickened zone.

8. An acoustic diaphragm of fibrous material of moderate average thickness and including thickened annular zones, one located at the periphery and the other located at an intermediate position, of substantial width and spaced from the peripheral thickened zone.

9. An acoustic diaphragm of fibrous material of moderate average thickness and including thickened annular zones, one located at the periphery and the other located at an intermediate position, of substantial width and spaced from the peripheral thickened zone and also in a location, relative to the axial dimension of the diaphragm, which is relatively near the outer peripheral zone and away from the apex of the diaphragm, leaving a relatively wide zone of minimum thickness extending from the apex to said intermediate thickened zone.

10. An acoustic diaphragm composed of a

plurality of layers of soft, rough paper, secured together by cement, peripheral strips of flexible material secured to the periphery of the diaphragm and projecting laterally for connection to a sound board or other support about an opening thereof.

11. An acoustic diaphragm of fibrous material of moderate average thickness and including thickened annular zones, one located at the periphery and the other located at an intermediate position, of substantial width and spaced from the peripheral thickened zone, peripheral strips of flexible material secured to the periphery of the diaphragm and projecting laterally for connection to a sound board or other support about an opening thereof.

12. An acoustic diaphragm composed of a plurality of layers of soft crepelike paper secured together by contractile cement.

In testimony whereof I have signed this specification this 4th day of October 1930.

CHARLES F. DILKS.

25

30

35

40

45

50

55

60