

(19) World Intellectual Property Organization
International Bureau



(43) International Publication Date
11 May 2006 (11.05.2006)

PCT

(10) International Publication Number
WO 2006/050023 A2

(51) International Patent Classification: Not classified

(74) Agent: MCKENNA, Richard, J.; FOLEY & LARDNER LLP, 777 East Wisconsin Avenue, Milwaukee, Wisconsin 53202 (US).

(21) International Application Number:
PCT/US2005/038762

(81) Designated States (unless otherwise indicated, for every kind of national protection available): AE, AG, AL, AM, AT, AU, AZ, BA, BB, BG, BR, BW, BY, BZ, CA, CH, CN, CO, CR, CU, CZ, DE, DK, DM, DZ, EC, EE, EG, ES, FI, GB, GD, GE, GH, GM, HR, HU, ID, IL, IN, IS, JP, KE, KG, KM, KP, KR, KZ, LC, LK, LR, LS, LT, LU, LV, LY, MA, MD, MG, MK, MN, MW, MX, MZ, NA, NG, NI, NO, NZ, OM, PG, PH, PL, PT, RO, RU, SC, SD, SE, SG, SK, SL, SM, SY, TJ, TM, TN, TR, TT, TZ, UA, UG, US, UZ, VC, VN, YU, ZA, ZM, ZW.

(22) International Filing Date: 26 October 2005 (26.10.2005)

(25) Filing Language: English

(26) Publication Language: English

(30) Priority Data:
10/978,722 29 October 2004 (29.10.2004) US
10/978,970 29 October 2004 (29.10.2004) US

(71) Applicant (for all designated States except US):
MEDTRONIC, INC. [US/US]; 710 Medtronic Parkway NE, Minneapolis, Minnesota 55432 (US).

(84) Designated States (unless otherwise indicated, for every kind of regional protection available): ARIPO (BW, GH, GM, KE, LS, MW, MZ, NA, SD, SL, SZ, TZ, UG, ZM, ZW), Eurasian (AM, AZ, BY, KG, KZ, MD, RU, TJ, TM), European (AT, BE, BG, CH, CY, CZ, DE, DK, EE, ES, FI, FR, GB, GR, HU, IE, IS, IT, LT, LU, LV, MC, NL, PL, PT, RO, SE, SI, SK, TR), OAPI (BF, BJ, CF, CG, CI, CM, GA, GN, GQ, GW, ML, MR, NE, SN, TD, TG).

(72) Inventors; and

(75) Inventors/Applicants (for US only): **HOWARD, William, G.** [US/US]; 2550 North Fisk Street, Roseville, MN 55113 (US). **SCHMIDT, Craig, L.** [US/US]; 831 Hidden Meadow Trail, Eagan, Minnesota 55311 (US). **SCOTT, Erik, R.** [US/US]; 7781 Shenandoah Lane N., Maple Grove, Minnesota 55311 (US).

Declarations under Rule 4.17:

— as to applicant's entitlement to apply for and be granted a patent (Rule 4.17(ii))

[Continued on next page]

(54) Title: LITHIUM-ION BATTERY AND MEDICAL DEVICE

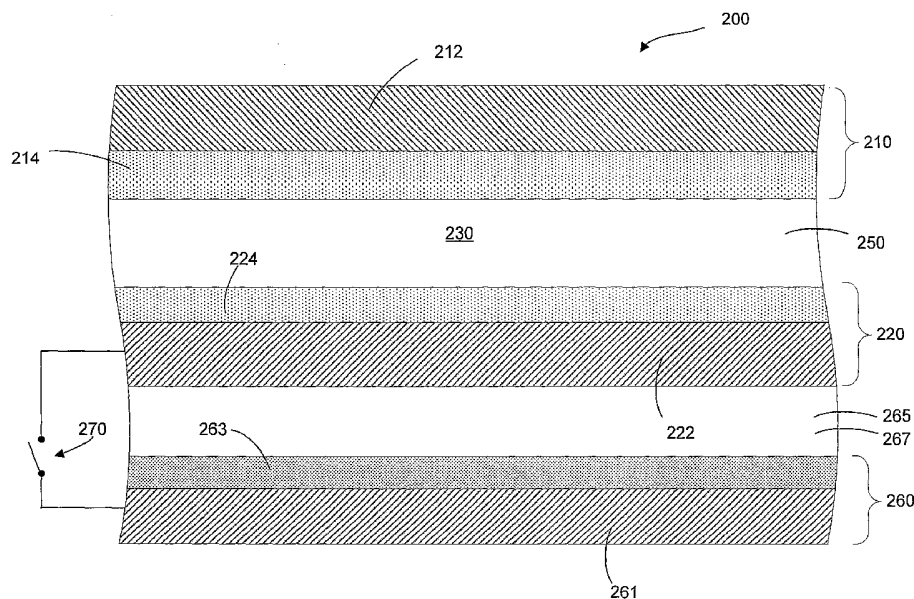

(57) Abstract: A battery includes a positive electrode having a current collector and a first active material and a negative electrode having a current collector and a second active material. The battery also includes an auxiliary electrode having a current collector and a third active material. The auxiliary electrode is configured for selective electrical connection to one of the positive electrode and the negative electrode. The first active material, second active material, and third active material are configured to allow doping and undoping of lithium ions. The third active material exhibits charging and discharging capacity below a corrosion potential of the current collector of the negative electrode and above a decomposition potential of the first active material.

WO 2006/050023 A2



— *as to the applicant's entitlement to claim the priority of the earlier application (Rule 4.17(iii))*

Published:

— *without international search report and to be republished upon receipt of that report*

For two-letter codes and other abbreviations, refer to the "Guidance Notes on Codes and Abbreviations" appearing at the beginning of each regular issue of the PCT Gazette.

LITHIUM-ION BATTERY AND MEDICAL DEVICE

BACKGROUND

[0001] The present invention relates generally to the field of lithium batteries. Specifically, the present invention relates to lithium-ion batteries that are relatively tolerant to over-discharge conditions.

[0002] Lithium-ion batteries include a positive current collector (e.g., aluminum such as an aluminum foil) having an active material provided thereon (e.g., LiCoO_2) and a negative current collector (e.g., copper such as a copper foil) having an active material (e.g., a carbonaceous material such as graphite) provided thereon. Together the positive current collector and the active material provided thereon are referred to as a positive electrode, while the negative current collector and the active material provided thereon are referred to as a negative electrode.

[0003] FIGURE 1 shows a schematic representation of a portion of a lithium-ion battery 10 such as that described above. The battery 10 includes a positive electrode 20 that includes a positive current collector 22 and a positive active material 24, a negative electrode 30 that includes a negative current collector 32 and a negative active material 34, an electrolyte material 40, and a separator (e.g., a polymeric microporous separator, not shown) provided intermediate or between the positive electrode 20 and the negative electrode 30. The electrodes 20, 30 may be provided as relatively flat or planar plates or may be wrapped or wound in a spiral or other configuration (e.g., an oval configuration). The electrode may also be provided in a folded configuration.

[0004] During charging and discharging of the battery 10, lithium ions move between the positive electrode 20 and the negative electrode 30. For example, when the battery 10 is discharged, lithium ions flow from the negative electrode 30 to the positive electrode 20. In contrast, when the battery 10 is charged, lithium ions flow from the positive electrode 20 to the negative electrode 30.

[0005] FIGURE 2 is a graph 100 illustrating the theoretical charging and discharging behavior for a conventional lithium-ion battery. Curve 110 represents the electrode potential versus a lithium reference electrode for a positive electrode that includes an aluminum current collector having a LiCoO_2 active material provided thereon, while curve 120 represents the electrode potential versus a lithium reference electrode for a negative electrode that includes a copper current collector having a carbonaceous active material provided thereon. The difference between curves 110 and 120 is representative of the overall cell voltage.

[0006] As shown in FIGURE 2, upon initial charging to full capacity, the potential of the positive electrode, as shown by curve 110, increases from approximately 3.0 volts to a point above the corrosion potential of copper used to form the negative electrode (designated by dashed line 122). The potential of the negative electrode decreases from approximately 3.0 volts to a point below the decomposition potential of the LiCoO_2 active material provided on the aluminum current collector (designated by dashed line 112). Upon initial charging, the battery experiences an irreversible loss of capacity due to the formation of a passive layer on the negative current collector, which may be referred to as a solid-electrolyte interface ("SEI"). The irreversible loss of capacity is shown as a ledge or shelf 124 in curve 120.

[0007] One difficulty with conventional lithium-ion batteries is that when such a battery is discharged to a point near zero volts, it may exhibit a loss of deliverable capacity and corrosion of the negative electrode current collector (copper) and possibly of the battery case, depending on the material used and the polarity of the case. As shown in FIGURE 2, after initial charging of the battery, a subsequent discharge of the battery in which the voltage of the battery approaches zero volts (i.e., zero percent capacity) results in a negative electrode potential that follows a path designated by dashed line 126. As shown in FIGURE 2, the negative electrode potential levels off or plateaus at the copper corrosion potential of the negative current collector (approximately 3.5 volts for copper and designated by dashed line 122 in FIGURE 2).

[0008] The point at which the curves 110 and 120 cross is sometimes referred to as the zero voltage crossing potential, and corresponds to a cell voltage that is equal to zero (i.e., the difference between the two curves equals zero at this point). Because of the degradation

of the copper current collector which occurs at the copper corrosion potential, the copper material used for the negative current collector corrodes before the cell reaches a zero voltage condition, resulting in a battery that exhibits a dramatic loss of deliverable capacity.

[0009] While FIGURE 2 shows the theoretical charging and discharging behavior of a battery that may experience corrosion of the negative current collector when the battery approaches a zero voltage configuration, it should be noted that there may also be cases in which the active material on the positive current collector may degrade in near-zero-voltage conditions. In such cases, the theoretical potential of the positive electrode versus a lithium reference electrode would decrease to the decomposition potential of the positive active material (shown as line 112 in FIGURE 2), at which point the positive active material would decompose, resulting in potentially decreased protection against future over-discharge conditions.

[0010] Because damage to the lithium-ion battery may occur in the event of a low voltage condition, conventional lithium-ion batteries may include protection circuitry and/or may be utilized in devices that include protection circuitry which substantially reduces the current drain from the battery (e.g., by disconnecting the battery).

[0011] The medical device industry produces a wide variety of electronic and mechanical devices for treating patient medical conditions. Depending upon the medical condition, medical devices can be surgically implanted or connected externally to the patient receiving treatment. Clinicians use medical devices alone or in combination with drug therapies and surgery to treat patient medical conditions. For some medical conditions, medical devices provide the best, and sometimes the only, therapy to restore an individual to a more healthful condition and a fuller life.

[0012] It may be desirable to provide a source of battery power for such medical devices, including implantable medical devices. In such cases, it may be advantageous to provide a battery that may be recharged. It may also be advantageous to provide a battery that may be discharged to a near zero voltage condition without substantial risk that the battery may be damaged (e.g., without corroding one of the electrodes or the battery case, decomposing the positive active material, etc.) such that the performance of the battery is degraded in subsequent charging and discharging operations.

[0013] It would be advantageous to provide a battery (e.g., a lithium-ion battery) that may be discharged to near zero volts without producing a subsequent decrease in the amount of deliverable capacity or producing a corroded negative electrode or battery case. It would also be advantageous to provide a battery that compensates for the irreversible loss of capacity resulting from initial charging of the battery to allow the battery to be used in near zero voltage conditions without significant degradation to battery performance. It would also be advantageous to provide a medical device (e.g., an implantable medical device) that utilizes a battery that includes any one or more of these or other advantageous features.

SUMMARY

[0014] An exemplary embodiment relates to a battery includes a positive electrode having a current collector and a first active material and a negative electrode having a current collector and a second active material. The battery also includes an auxiliary electrode having a current collector and a third active material. The auxiliary electrode is configured for selective electrical connection to one of the positive electrode and the negative electrode. The first active material, second active material, and third active material are configured to allow doping and undoping of lithium ions. The third active material exhibits charging and discharging capacity below a corrosion potential of the current collector of the negative electrode and above a decomposition potential of the first active material.

[0015] Another exemplary embodiment relates to a lithium-ion battery that includes a first electrode including a first current collector and a first active material provided on the first current collector. The lithium-ion battery also includes a second electrode including a second current collector and a second active material provided on the second current collector. The lithium-ion battery further includes a third electrode including a third current collector and a third active material provided on the third current collector. The third electrode is configured for selective electrical coupling to and decoupling from the second electrode:

[0016] Another exemplary embodiment relates to lithium-ion battery having a positive electrode including a positive current collector and an active material provided on at least one side of the positive current collector. The lithium-ion battery also includes a negative electrode having a negative current collector and a primary active material provided on at

least one side of the negative current collector. The lithium-ion battery also includes an auxiliary electrode having a current collector and an auxiliary active material provided on at least one side of the current collector of the auxiliary electrode. The auxiliary electrode configured to be selectively coupled to the negative electrode when a predetermined condition is present.

BRIEF DESCRIPTION OF THE DRAWINGS

[0017] FIGURE 1 is a schematic cross-sectional view of a conventional lithium-ion battery.

[0018] FIGURE 2 is a graph illustrating the theoretical charging and discharging behavior for a conventional lithium-ion battery such as that shown schematically in FIGURE 1.

[0019] FIGURE 3 is a schematic view of a portion of a lithium-ion battery having an auxiliary negative electrode according to an exemplary embodiment.

[0020] FIGURE 4 is a schematic view of the lithium-ion battery shown in FIGURE 3 according to one exemplary embodiment.

[0021] FIGURE 5 is a schematic view of the lithium-ion battery shown in FIGURE 3 according to another exemplary embodiment.

[0022] FIGURE 6 is a schematic cross-sectional view of a portion of the lithium-ion battery shown in FIGURE 3 according to one exemplary embodiment.

[0023] FIGURE 7 is a schematic cross-sectional view of a portion of the lithium-ion battery shown in FIGURE 3 according to another exemplary embodiment.

[0024] FIGURE 8 is a graph illustrating the theoretical charging and discharging behavior for a lithium-ion battery such as that shown in FIGURE 3.

[0025] FIGURE 9 is a schematic view of a portion of a lithium-ion battery having an auxiliary positive electrode according to an exemplary embodiment.

[0026] FIGURE 10 is a schematic view of the lithium-ion battery shown in FIGURE 9 according to one exemplary embodiment.

[0027] FIGURE 11 is a schematic view of the lithium-ion battery shown in FIGURE 9 according to another exemplary embodiment.

[0028] FIGURE 12 is a schematic cross-sectional view of a portion of the lithium-ion battery shown in FIGURE 9 according to one exemplary embodiment.

[0029] FIGURE 13 is a schematic cross-sectional view of a portion of the lithium-ion battery shown in FIGURE 9 according to another exemplary embodiment.

[0030] FIGURE 14 is a schematic view of a system in the form of an implantable medical device implanted within a body or torso of a patient.

[0031] FIGURE 15 is schematic view of another system in the form of an implantable medical device.

DETAILED DESCRIPTION OF EXEMPLARY EMBODIMENTS

[0032] With reference to FIGURE 3, a schematic view of a portion of a lithium-ion battery 200 having a case 202 is shown according to an exemplary embodiment. According to an exemplary embodiment, the battery 200 has a rating of between approximately 10 and 1000 milliampere hours (mAh). According to another exemplary embodiment, the battery has a rating of between approximately 100 and 400 mAh. According to another exemplary embodiment, the battery is an approximately 300 mAh battery. According to another exemplary embodiment, the battery is an approximately 75 mAh battery.

[0033] The battery 200 includes at least one positive electrode 210, at least one negative electrode 220, and an auxiliary electrode 260 that may be selectively electrically connected or coupled to the negative electrode 220 (e.g., by a switch 270, and according to another exemplary embodiment, according to a diode or other device). The auxiliary electrode 260, while being shown in the headspace of the battery 200, may be provided in other locations as may be desired. Also, it should be noted that one of the positive electrode 210 and negative electrode 220 may be coupled to the case 202 (e.g., as opposed to being electrically isolated from the case) according to other exemplary embodiments. The electrodes may be provided as flat or planar components of the battery 200, may be wound in a spiral or other configuration, or may be provided in a folded configuration. For example, the electrodes may be wrapped around a relatively rectangular mandrel such that they form an oval wound

coil for insertion into a relatively prismatic battery case. According to other exemplary embodiments, the battery may be provided as a button cell battery, a thin film solid state battery, or as another lithium-ion battery configuration.

[0034] The battery case may be made of stainless steel or another metal. According to an exemplary embodiment, the battery case may be made of titanium, aluminum, or alloys thereof. According to another exemplary embodiment, the battery case may be made of a plastic material or a plastic-foil laminate material (e.g., an aluminum foil provided intermediate a polyolefin layer and a polyester layer).

[0035] According to an exemplary embodiment, the negative electrode is coupled to a stainless steel case by a member or tab comprising nickel or a nickel alloy. An aluminum or aluminum alloy member or tab may be coupled or attached to the positive electrode. The nickel and aluminum tabs may serve as terminals for the battery according to an exemplary embodiment.

[0036] The dimensions of the battery 200 may differ according to a variety of exemplary embodiments. For example, according to one exemplary embodiment in which the electrodes are wound such that they may be provided in a relatively prismatic battery case, the battery has dimensions of between approximately 30-40 mm by between approximately 20-30 mm by between approximately 5-7 mm. According to another exemplary embodiment, the dimensions of the battery are approximately 20 mm by 20 mm by 3 mm. According to another exemplary embodiment, a battery may be provided in the form of a button cell type battery having a diameter of approximately 30 mm and a thickness of approximately 3 mm. It will be appreciated by those of skill in the art that such dimensions and configurations as are described herein are illustrative only, and that batteries in a wide variety of sizes, shapes, and configurations may be produced in accordance with the novel concepts described herein.

[0037] According to an exemplary embodiment, the negative electrode 220 and the auxiliary electrode 260 are provided within the battery such that they are electrically isolated from one another. For example, an insulative material (e.g., a porous polymeric material (e.g., polypropylene, polyethylene, etc.), a glass, or a ceramic material) may be provided between the negative electrode 220 and the auxiliary electrode 260.

[0038] The auxiliary electrode 260 may be selectively electrically connected or coupled to the negative electrode 220 by way of a connection provided external to the battery. The selective electrical connection and disconnection between the auxiliary electrode 260 and the negative electrode 220 may be accomplished in any of a variety of ways. For example, FIGURE 4 illustrates a configuration in which the auxiliary electrode 260 and negative electrode 220 are connected by way of a diode 262 (or a plurality of diodes according to another embodiment) placed between the auxiliary electrode 260 and the negative electrode 220. According to this exemplary embodiment, the diode or series of diodes may be configured such that an electrical connection between the auxiliary electrode 260 and negative electrode 220 occurs only when the potential difference between the negative electrode 220 and the auxiliary electrode 260 exceeds a predetermined threshold value (e.g., approximately 0.3 volts according to an exemplary embodiment and between approximately 0.1 and 0.5 volts according to another exemplary embodiment). The auxiliary electrode 260 and the negative electrode 220 may be disconnected (i.e., electrically isolated) whenever the potential difference between the negative electrode and the auxiliary electrode falls below the predetermined value. According to an exemplary embodiment, the diode 262 is a 0.3 volt diode. According to other exemplary embodiments, the diode 262 or series of diodes have a voltage of between approximately 0.2 and 0.7 volts. According to an exemplary embodiment, the potential difference at which the connection and disconnection of the auxiliary electrode 260 and the negative electrode 220 occurs is selected such that the potential of the auxiliary electrode material always remains above its reductive decomposition potential.

[0039] FIGURE 5 illustrates a configuration for the battery 200 according to another exemplary embodiment. A control circuit 264 (which may be implemented in hardware, software, or firmware, for example) receives input signals from a voltmeter 266 which measures the voltage between the positive electrode 210 and the negative electrode 220. When the voltage difference between the positive electrode 210 and the negative electrode 220 falls below a predetermined threshold (e.g., 1.8 volts), the control circuit instructs a switch 270 to close, thereby electrically connecting the auxiliary electrode 260 to the negative electrode 220. The switch 270 may be instructed to open (thus electrically disconnecting the negative electrode 220 and the auxiliary electrode 260) when the voltage difference between the positive electrode 210 and the negative electrode 220 exceeds the predetermined threshold.

[0040] While FIGURES 4 and 5 illustrate two embodiments in which the auxiliary electrode 260 would be electrically connected to the negative electrode 220, it should be understood by those of skill in the art that any of a variety of other mechanisms may be utilized in order to electrically connect the auxiliary electrode to the negative electrode when a predetermined condition has been satisfied. As such, the embodiment shown in FIGURES 4 and 5 should not be understood to be limiting to the scope of the invention as described in the appended claims.

[0041] FIGURE 6 is a schematic cross-sectional view of a portion of the battery 200 shown in FIGURE 3. The battery 200 includes a positive electrode 210, a negative electrode 220, and an auxiliary electrode 260. The auxiliary electrode 260 may be selectively electrically coupled or connected to the negative electrode 220 by virtue of a switch 270 or other means. It should be understood that switch 270 may be a mechanism such as, but not limited to, those devices such as in the embodiments shown in FIGURES 4 and 5.

[0042] An electrolyte 230 is provided intermediate or between the positive and negative electrodes to provide a medium through which lithium ions may travel. According to an exemplary embodiment, the electrolyte may be a liquid (e.g., a lithium salt dissolved in one or more non-aqueous solvents). According to another exemplary embodiment, the electrolyte may be a lithium salt dissolved in a polymeric material such as poly(ethylene oxide) or silicone. According to another exemplary embodiment, the electrolyte may be an ionic liquid such as N-methyl-N-alkylpyrrolidinium bis(trifluoromethanesulfonyl)imide salts. According to another exemplary embodiment, the electrolyte may be a solid state electrolyte such as a lithium-ion conducting glass such as lithium phosphorous oxynitride (LiPON).

[0043] Various other electrolytes may be used according to other exemplary embodiments. For example, according to an exemplary embodiment, the electrolyte may be a 1:1 mixture of ethylene carbonate to diethylene carbonate (EC:DEC) in a 1.0 M salt of LiPF_6 . According to another exemplary embodiment, the electrolyte may include a polypropylene carbonate solvent and a lithium bis-oxalatoborate salt (sometimes referred to as LiBOB). According to other exemplary embodiments, the electrolyte may comprise one or more of a PVDF copolymer, a PVDF-polyimide material, and organosilicon polymer, a

thermal polymerization gel, a radiation cured acrylate, a particulate with polymer gel, an inorganic gel polymer electrolyte, an inorganic gel-polymer electrolyte, a PVDF gel, polyethylene oxide (PEO), a glass ceramic electrolyte, phosphate glasses, lithium conducting glasses, lithium conducting ceramics, and an inorganic ionic liquid gel, among others.

[0044] A separator 250 is provided intermediate or between the positive electrode 210 and the negative electrode 220. According to an exemplary embodiment, the separator 250 is a polymeric material such as a polypropylene/polyethylene or another polyolefin multilayer laminate that includes micropores formed therein to allow electrolyte and lithium ions to flow from one side of the separator to the other. The thickness of the separator 250 is between approximately 10 micrometers (μm) and 50 μm according to an exemplary embodiment. According to a particular exemplary embodiment, the thickness of the separator is approximately 25 μm and the average pore size of the separator is between approximately 0.02 μm and 0.1 μm .

[0045] The auxiliary electrode 260 is electrically isolated from the negative electrode 220 internal to the battery, and is electrically connected to the negative electrode 220 only by virtue of the external connection means (shown, e.g., as switch 270). An insulative material 265 such as a porous polypropylene or polyethylene separator, a glass (e.g., Cabal-12 glass), or a ceramic material (e.g., alumina) may be provided intermediate or between the negative electrode 220 and the auxiliary electrode 260 according to exemplary embodiment (an electrolyte 267 similar to that described above as electrolyte 230 may also be provided intermediate or between the auxiliary electrode 260 and the negative electrode 220).

[0046] The positive electrode 210 includes a current collector 212 made of a conductive material such as a metal. According to an exemplary embodiment, the current collector 212 comprises aluminum or an aluminum alloy. According to an exemplary embodiment, the thickness of the current collector 212 is between approximately 5 μm and 75 μm . According to a particular exemplary embodiment, the thickness of the current collector 212 is approximately 20 μm . It should also be noted that while the positive current collector 212 has been illustrated and described as being a thin foil material, the positive current collector may have any of a variety of other configurations according to various exemplary

embodiments. For example, the positive current collector may be a grid such as a mesh grid, an expanded metal grid, a photochemically etched grid, or the like.

[0047] The current collector 212 has a layer of active material 214 provided thereon (e.g., coated on the current collector). While FIGURE 3 shows that the active material 214 is provided on only one side of the current collector 212, it should be understood that a layer of active material similar or identical to that shown as active material 214 may be provided or coated on both sides of the current collector 212.

[0048] According to an exemplary embodiment, the active material 214 is a material or compound that includes lithium. The lithium included in the active material 214 may be doped and undoped during discharging and charging of the battery, respectively. According to an exemplary embodiment, the active material 214 is lithium cobalt oxide (LiCoO₂). According to another exemplary embodiment, the positive active material is of the form LiCo_xNi_(1-x)O₂, with x being between approximately 0.05 and 0.8. According to another exemplary embodiment, the primary active material is of the form LiM_xCo_yNi_(1-x-y)O₂, where M is aluminum or titanium, x is between approximately 0.05 and 0.3 and y is between approximately 0.1 and 0.3. According to another exemplary embodiment, the positive active material is LiCo_xMn_yNi_zO₂ or LiNi_xCo_yAl_zO₂. According to other exemplary embodiments, the primary active material may include LiMn₂O₄.

[0049] According to various other exemplary embodiments, the primary active material may include a material such as a material of the form Li_{1-x}MO₂ where M is a metal (e.g., LiCoO₂, LiNiO₂, and LiMnO₂), a material of the form Li_{1-w}(M'_xM''_y)O₂ where M' and M'' are different metals (e.g., Li(Ni_xMn_y)O₂, Li(Ni_{1/2}Mn_{1/2})O₂, Li(Cr_xMn_{1-x})O₂, Li(Al_xMn_{1-x})O₂, Li(Co_xM_{1-x})O₂, Li(Co_xNi_{1-x})O₂, and Li(Co_xFe_{1-x})O₂), a material of the form Li_{1-w}(Mn_xNi_yCo_z)O₂ (e.g., LiCo_xMn_yNi_(1-x-y)O₂, Li(Mn_{1/3}Ni_{1/3}Co_{1/3})O₂, Li(Mn_{1/3}Ni_{1/3}Co_{1/3}Mg_x)O₂, Li(Mn_{0.4}Ni_{0.4}Co_{0.2})O₂, and Li(Mn_{0.1}Ni_{0.1}Co_{0.8})O₂), a material of the form Li_{1-w}(Mn_xNi_xCo_{1-2x})O₂, a material of the form Li_{1-w}(Mn_xNi_yCo_zAl_w)O₂, a material of the form Li_{1-w}(Ni_xCo_yAl_z)O₂ (e.g., Li(Ni_{0.8}Co_{0.15}Al_{0.05})O₂), a material of the form Li_{1-w}(Ni_xCo_yM_z)O₂ where M is a metal, a material of the form Li_{1-w}(Ni_xMn_yM_z)O₂ where M is a metal, a material of the form Li(Ni_{x-y}Mn_yCr_{2-x})O₄, LiMn₂O₄, a material of the form LiM'_xM''_yO₄ where M' and M'' are different metals (e.g., LiMn_{2-y-z}Ni_y, Li_zO₄, LiMn_{1.5}Ni_{0.5}O₄, LiNiCuO₄, LiMn_{1-x}Al_xO₄, LiNi_{0.5}Ti_{0.5}O₄, and Li_{1.05}Al_{0.1}Mn_{1.85}O_{4-z}F_z), Li₂MnO₃, a material

of the form $\text{Li}_x\text{V}_y\text{O}_z$ (e.g., LiV_3O_8 , LiV_2O_5 , and $\text{LiV}_6\text{O}_{13}$), a material of the form LiMPO_4 where M is a metal or $\text{LiM}_x\text{M}'_{1-x}\text{PO}_4$ where M' and M'' are different metals (e.g., LiFePO_4 , $\text{LiFe}_x\text{M}_{1-x}\text{PO}_4$, LiVOPO_4 , and $\text{Li}_3\text{V}_2(\text{PO}_4)_3$, LiMPO_{4x} where M is a metal such as iron or vanadium and x is a halogen such as fluorine, and combinations thereof.

[0050] A binder material may also be utilized in conjunction with the active material 214. For example, according to an exemplary embodiment, the active material may include a conductive additive such as carbon black and a binder such as polyvinylidene fluoride (PVDF) or an elastomeric polymer.

[0051] According to an exemplary embodiment, the thickness of the active material 214 is between approximately 0.1 μm and 3 mm. According to a particular exemplary embodiment, the thickness of the active material 214 is between approximately 25 μm and 300 μm . According to a particular exemplary embodiment, the thickness of the layer of active material 214 is approximately 75 μm .

[0052] The negative current collector 222 included as part of the negative electrode 220 is made of a conductive material such as a metal. According to an exemplary embodiment, the current collector 222 is copper or a copper alloy. According to another exemplary embodiment, the current collector 222 is titanium or a titanium alloy. According to another exemplary embodiment, the current collector 222 is nickel or a nickel alloy. According to another exemplary embodiment in which the negative active material 224 is not carbon, the current collector 222 is aluminum or an aluminum alloy. It should also be noted that while the negative current collector 222 has been illustrated and described as being a thin foil material, the positive current collector may have any of a variety of other configurations according to various exemplary embodiments. For example, the positive current collector may be a grid such as a mesh grid, an expanded metal grid, a photochemically etched grid, or the like.

[0053] According to an exemplary embodiment, the thickness of the current collector 222 is between approximately 100 nm and 100 μm . According to a particular exemplary embodiment, the thickness of the current collector 222 is between approximately 5 μm and 25 μm . According to a particular exemplary embodiment, the thickness of the current collector is approximately 10 μm .

[0054] The negative current collector 222 has a layer of active material 224 provided thereon. While FIGURE 3 shows that the active material 224 is provided on only one side of the current collector 222, it should be understood that a layer of active material similar or identical to that shown may be provided or coated on both sides of the current collector 222. According to an exemplary embodiment, the active material 224 may include a conductive additive such as carbon black and a binder such as polyvinylidene fluoride (PVDF) or an elastomeric polymer.

[0055] According to an exemplary embodiment the active material 224 is a carbonaceous material (e.g., carbon such as graphite). According to another exemplary embodiment, the active material 224 is a lithium titanate material such as $\text{Li}_4\text{Ti}_5\text{O}_{12}$. One advantage of using a lithium titanate material in place of a carbonaceous material is that it is believed that the use of a lithium titanate material allows for charging and discharging of the battery at higher rates than is capable using carbonaceous materials.

[0056] Other lithium titanate materials which may be suitable for use as the active material 224 may include one or more of include the following lithium titanate spinel materials: $\text{H}_x\text{Li}_{y-x}\text{TiO}_x\text{O}_4$, $\text{H}_x\text{Li}_{y-x}\text{TiO}_x\text{O}_4$, $\text{Li}_4\text{M}_x\text{Ti}_{5-x}\text{O}_{12}$, $\text{Li}_x\text{Ti}_y\text{O}_4$, $\text{Li}_x\text{Ti}_y\text{O}_4$, $\text{Li}_4[\text{Ti}_{1.67}\text{Li}_{0.33-y}\text{M}_y]\text{O}_4$, Li_2TiO_3 , $\text{Li}_4\text{Ti}_{4.75}\text{V}_{0.25}\text{O}_{12}$, $\text{Li}_4\text{Ti}_{4.75}\text{Fe}_{0.25}\text{O}_{11.88}$, and $\text{Li}_4\text{Ti}_{4.5}\text{Mn}_{0.5}\text{O}_{12}$, and $\text{LiM}'\text{M}''\text{XO}_4$ (where M' is a transition metal, M'' is an optional three valent non-transition metal, and X is zirconium, titanium, or a combination of these two, and where M' is nickel, cobalt, iron, manganese, vanadium, copper, chromium, molybdenum, niobium, or combinations thereof). Note that such lithium titanate spinel materials may be used in any state of lithiation (e.g., $\text{Li}_{4+x}\text{Ti}_5\text{O}_{12}$, where $0 \leq x \leq 3$).

[0057] One advantage of using a lithium titanate material instead of a carbonaceous material is that it is believed that the use of a lithium titanate material allows for charging and discharging of the battery at higher rates than is capable using carbonaceous materials. According to other exemplary embodiments, the negative active material 224 may be carbon, Li_xAl , Li_xSn , Li_xSi , Li_xSnO , metal nanoparticle composites (e.g., including Li_xAl , Li_xSn , Li_xSi , or Li_xSnO), or carbon-coated lithium titanate. Lithium titanate materials are also believed to offer superior cycle life because they are so called "zero-strain" materials. Zero strain materials have crystal lattices which do not experience shrinkage or contraction

with lithium doping/de-doping, making them free from strain-related degradation mechanisms.

[0058] Another advantageous feature of using a lithium titanate material is that it is believed that when used in a negative electrode of a lithium-ion battery, such materials will cycle lithium at a potential plateau of about 1.5 V versus a lithium reference electrode. This is substantially higher than graphitic carbon, which is traditionally used in lithium ion batteries, and cycles lithium down to about 0.1 V in the fully charged state. As a result, the battery using lithium titanate is believed to be less likely to result in plating of lithium (which occurs at 0 V versus a lithium reference) while being charged. Lithium plating is a well-known phenomenon that can lead to loss in performance of lithium ion batteries. Being free from the risk lithium plating, cells with lithium titanate negative electrodes may also be charged at rates that exceed those with carbon negative electrodes. For example, a common upper limit for the rate of charge in lithium ion batteries is about 1C (meaning that the battery can be fully charged from the discharged state in one hour). Conversely, it has been reported in literature that lithium titanate may be charged at rates up to 10C (i.e., attaining full charge in 1/10 hour, or six minutes). Being able to recharge a battery more quickly substantially increases the functionality of devices that employ such a battery. A further advantage of the higher potential of the lithium titanate material is that it avoids decomposition of organic solvents (such as propylene carbonate) commonly used in lithium ion batteries. In so doing, it may reduce negative consequences such as formation of gas, cell swelling, reduction of reversible battery capacity, and buildup of resistive films which reduce battery power.

[0059] According to various exemplary embodiments, the thickness of the active material 224 is between approximately 0.1 μm and 3 mm. According to other exemplary embodiments, the thickness of the layer of active material 224 may be between approximately 25 μm and 300 μm . According to a particular exemplary embodiment, the thickness of the active material 224 is approximately 75 μm .

[0060] The auxiliary electrode 260 includes a current collector 261 that is made of a conductive material such as a metal. According to an exemplary embodiment, the current collector 261 is titanium or a titanium alloy. According to another exemplary embodiment, the current collector 261 may be aluminum or an aluminum alloy. According to other

exemplary embodiments, the current collector 261 may be nickel, stainless steel, or another suitable metal material. It should also be noted that while the current collector 261 has been illustrated and described as being a thin foil material, the current collector may have any of a variety of configurations according to various exemplary embodiments. For example, the current collector may be a grid such as a mesh grid, and an expanded metal grid, a photochemically etched grid, or the like.

[0061] According to an exemplary embodiment, the thickness of the current collector 261 is between approximately 10 and 40 μm . According to another exemplary embodiment, the thickness of the current collector is between approximately 10 μm and 20 μm . According to a particular exemplary embodiment, the thickness of the current collector 261 is approximately 10 μm .

[0062] The current collector 261 has a layer of active material 263 provided thereon. While FIGURE 6 shows that the active material 263 is provided on only one side of the current collector 262, it should be understood that a layer of active material similar or identical to that shown may be provided or coated on both sides of the current collector 261.

[0063] The active material 263 is a material that is selected to have relatively significant charge and discharge capacity below the corrosion potential of the material used for the negative current collector 222 provided as part of the negative electrode 220 and above the decomposition potential of the active material 214 provided on the positive current collector 212. The active material 263 is also selected to be stable over its full potential-composition range in the electrolyte. For example, according to an exemplary embodiment in which the negative current collector 222 comprises copper, for which the corrosion potential is approximately 3.5 volts, the active material 263 includes significant charge and discharge capacity below 3.5 volts.

[0064] According to an exemplary embodiment in which the auxiliary electrode 260 is to be coupled to the negative electrode 220, the active material 263 must comprise lithium or be lithiated using a source of lithium (e.g., a lithium powder or a lithium patch, etc.) in electrical contact with the auxiliary electrode. According to an exemplary embodiment in which the active material 263 includes lithium, the active material is LiMn_2O_4 . According to various other exemplary embodiments, the active material may be selected from the following materials and combinations thereof: V_2O_5 , V_6O_{13} , LiMn_2O_4 (spinel), $\text{LiM}_x\text{Mn}_{2-x}$.

x)O₄ (spinel) where M is metal (including Li) and x is between approximately 0.05 and 0.4, Li₅Ti₄O₁₂, Li _{x} VO₂ (where x is between approximately 0 and 1), V₃O₈, MoO₃, TiS₂, WO₂, MoO₂, and RuO₂, as well as their partially or fully lithiated counterparts.

[0065] Any lithium included in the active material 263 of the auxiliary electrode 260 has significant charge/discharge capacity that lies below the corrosion potential of the negative current collector 222 and/or any battery components to which it is electrically connected (e.g., the case) and above the decomposition potential of the positive electrode active material 214. The active material 263 contains electrochemically active lithium in the as-constructed state. The lithium becomes significantly doped at a potential below the corrosion potential for the negative current collector 222. In so doing, this material lowers the final potential of the positive electrode in the discharge state, so that the zero voltage crossing potential remains below the corrosion potential of the negative current collector and the battery case. The active material 263 may be capable of releasing the lithium when the battery is charged.

[0066] It should be noted that while a variety of materials have been described above as being useful for active material 263, a variety of additional materials may be utilized in addition to or in place of such materials. For example, the active material 263 may comprise an oxide material such as one or more of Li _{x} MoO₃ ($0 < x \leq 2$), Li _{x} MoO₂ ($0 < x \leq 1$), Li _{x} Mo₂O₄ ($0 < x \leq 2$), Li _{x} MnO₂ ($0 < x \leq 1$), Li _{x} Mn₂O₄ ($0 < x \leq 2$), Li _{x} V₂O₅ ($0 < x \leq 2.5$), Li _{x} V₃O₈ ($0 < x \leq 3.5$), Li _{x} V₆O₁₃ ($0 < x \leq 6$ for Li _{x} VO_{2.19} and $0 < x \leq 3.6$ for Li _{x} VO_{2.17}), Li _{x} VO₂ ($0 < x \leq 1$), Li _{x} WO₃ ($0 < x \leq 1$), Li _{x} WO₂ ($0 < x \leq 1$), Li _{x} TiO₂ (anatase) ($0 < x \leq 1$), Li _{x} Ti₂O₄ ($0 < x \leq 2$), Li _{x} RuO₂ ($0 < x \leq 1$), Li _{x} Fe₂O₃ ($0 < x \leq 2$), Li _{x} Fe₃O₄ ($0 < x \leq 2$), Li _{x} Cr₂O ($0 < x \leq 3$), Li _{x} Cr ($0 < x \leq 3.8$), and Li _{x} Ni _{y} Co_{1- y} O₂ ($0 < x \leq 1$, $0.90 < y \leq 1.00$).

[0067] According to another exemplary embodiment, the active material 263 may comprise a sulfide material such as one or more of Li _{x} V₂S₅ ($0 < x \leq 4.8$), Li _{x} TaS₂ ($0 < x \leq 1$), Li _{x} FeS ($0 < x \leq 1$), Li _{x} FeS₂ ($0 < x \leq 1$), Li _{x} NbS₃ ($0 < x \leq 2.4$), Li _{x} MoS₃ ($0 < x \leq 3$), Li _{x} MoS₂ ($0 < x \leq 1$), Li _{x} TiS₂ ($0 < x \leq 1$), Li _{x} ZrS₂ ($0 < x \leq 1$), Li _{x} Fe_{0.25}V_{0.75}S₂ ($0 < x \leq 1$), Li _{x} Cr_{0.75}V_{0.25}S₂ ($0 < x \leq 0.65$), and Li _{x} Cr_{0.5}V_{0.5}S₂ ($0 < x \leq 1$).

[0068] According to another exemplary embodiment, the active material 263 may comprise a selenide material such as one or more of Li _{x} NbSe₃ ($0 < x \leq 3$), Li _{x} VSe₂ ($0 < x \leq$

1), or various other materials such as, for example, Li_xNiPS_3 ($0 < x \leq 1.5$) and Li_xFePS_3 ($0 < x \leq 1.5$).

[0069] According to an exemplary embodiment in which the active material 263 does not include lithium in the as-constructed state (e.g., the active material 263 is V_6O_{13}), a mechanism must be provided to lithiate the active material 263. According to an exemplary embodiment, a mass or quantity of lithium (e.g., a lithium "patch") may be provided, as will be discussed in greater detail below.

[0070] FIGURE 7 shows a battery 200 according to another exemplary embodiment in which a mass or quantity of lithium 240 (e.g., a lithium patch) is provided in electrical contact with current collector 261 of the auxiliary electrode 260 to lithiate active material 263. Such a configuration corresponds to a situation in which the active material 263 is provided without including electrochemically active lithium (e.g., the active material 263 does not include lithium as it is coated on the negative current collector). One such exemplary embodiment involves the use of V_2O_5 for the active material 263. In contrast, FIGURE 6 shows a configuration in which the active material 263 is provided as a lithiated material (e.g., LiMn_2O_4). In such an embodiment, a mass or quantity of lithium in contact with the current collector 261 of the auxiliary electrode 260 is not necessary.

[0071] The electrochemically active lithium may be provided in other locations in the negative electrode 220 and/or may have a different size or shape than that shown schematically in FIGURE 7. For example, the electrochemically active lithium may be provided as a disc or as a rectangular piece of material coupled to the negative current collector. While the electrochemically active lithium is shown as being provided on a single side of the current collector 261 in FIGURE 7 (e.g., as a lithium patch), separate lithium patches may be provided on opposite sides of the current collector 261. Further, multiple lithium patches may be provided on one or more of the sides of the current collector 261. In another example, the lithium may be provided elsewhere within the battery and connected (e.g., by a wire) to the current collector 261.

[0072] According to another exemplary embodiment, the electrochemically active or cyclable lithium may be added as finely divided or powdered lithium. Such powdered lithium includes a passive coating (e.g., a thin layer or film of lithium carbonate) provided thereon to reduce the reactivity of the powdered lithium with air and moisture. Such

material may be mixed with the negative electrode active material prior to application of the negative electrode active material to fabrication of the cells or may be added as another separate active material layer. According to an exemplary embodiment, the finely divided or powdered lithium has a diameter of between approximately 1 μm and 100 μm , and according to a particular embodiment, between approximately 5 μm and 30 μm .

[0073] According to an exemplary embodiment in which a lithium patch 240 is utilized, the size of the lithium patch 240 is sufficient to fully lithiate the auxiliary electrode active material 263. According to an exemplary embodiment, the size of the lithium patch is between approximately 1.4 cm x 1.4 cm x 0.11 cm, which corresponds to approximately 0.013 grams (e.g., approximately 50 mAh). The specific size of the lithium patch may vary according to other exemplary embodiments (e.g., approximately 5% of the capacity of either the negative or positive electrode).

[0074] FIGURE 8 is a graph 300 illustrating the theoretical charging and discharging behavior for a lithium-ion battery constructed in accordance with an exemplary embodiment such as that shown and described with regard to FIGURES 3-7. Curve 310 represents the electrode potential versus a lithium reference electrode for a positive electrode (e.g., positive electrode 210) that includes an aluminum current collector having a LiCoO_2 primary active material provided thereon.

[0075] Curve 320 represents the electrode potential versus a lithium reference electrode for a negative electrode that includes a copper current collector having an active material (i.e., an active material 224 including, for example, a carbonaceous material such as carbon), a non-lithiated active material provided on an auxiliary electrode, and a lithium patch provided on the auxiliary electrode. The difference between curves 310 and 320 is representative of the overall cell voltage of the battery.

[0076] The active material provided on the auxiliary electrode is selected to provide significant charging/discharging capacity below the corrosion potential (shown as dashed line 322) of the negative current collector and above the decomposition potential (shown as dashed line 312) of the LiCoO_2 positive electrode active material, in addition to its ability to remain stable over its full potential-composition range in the electrolyte. According to an exemplary embodiment, the secondary active material is V_6O_{13} . According to various other exemplary embodiments, the secondary active material may be selected from the following

materials and combinations thereof: V_2O_5 , V_6O_{13} , V_3O_8 , MoO_3 , TiS_2 , WO_2 , MoO_2 , and RuO_2 .

[0077] It should be noted that the theoretical charging and discharge behavior for the negative electrode is believed to be qualitatively similar to that shown in FIGURE 8 for a copper current collector having a $Li_4Ti_5O_{12}$ primary active material provided thereon (as opposed to a carbon active material), with the relatively flat portion of the curve 320 being shifted upward to a level of approximately 1.57 volts (in contrast to the approximately 0.1 volts for the carbon active material).

[0078] As shown in FIGURE 8, when the battery is first constructed and electrolyte is provided within the battery, the potentials of the positive and negative electrodes begin at the point shown as dashed line 313. Upon initial charging to full capacity, the potential of the positive electrode, as shown by curve 310, increases from approximately 3.0 volts (shown as point 311) to a point above the corrosion potential of copper used to form the negative current collector (designated by dashed line 322). When the battery is subsequently discharged toward a zero voltage condition, the positive electrode potential will continue along a portion 314 of curve 310 to a point below approximately 3.0 volts (as shown by the dashed portion of curve 310 in FIGURE 8).

[0079] The potential of the negative electrode decreases from a point below approximately 2.0 volts on initial charging to a point below the decomposition potential of the $LiCoO_2$ active material provided on the positive current collector (designated by dashed line 312 and below the decomposition potential of the secondary or auxiliary active material (designated by dashed line 332)). According to an exemplary embodiment, the corrosion potential of copper is approximately 3.5 volts, while the decomposition potential of the $LiCoO_2$ active material provided on the positive current collector is approximately 1.6 volts. According to another exemplary embodiment, the decomposition potential of the $LiCoO_2$ active material is approximately 1.35 volts.

[0080] The irreversible loss of capacity of the battery is shown as a ledge or shelf 324 in curve 320. Upon discharging the battery to a point approaching zero volts, the negative electrode potential follows a path designated by a dashed portion 326 of the curve 320. As the potential of the negative electrode moves above the decomposition potential of the auxiliary active material (designated as dash line 332), the auxiliary electrode is electrically

connected to the negative electrode, remaining in electrical contact through complete discharging of the battery cell. Upon recharging the battery, the auxiliary electrode will be electrically disconnected from the negative electrode when the potential of the negative electrode moves below the decomposition potential of the auxiliary active material.

[0081] Because the active material on the negative current collector is chosen to have significant charging/discharging capacity below the corrosion potential of the negative current collector and above the decomposition potential of the LiCoO_2 primary active material, the zero voltage crossing potential (shown as point 330) is below the corrosion potential of the negative current collector and above the decomposition potential of the LiCoO_2 primary active material, thus avoiding corrosion of the negative current collector (and potentially of the battery case or any other battery component in electrical contact or communication with the negative electrode) and any associated loss of battery charging capacity. One advantageous feature of such an arrangement is that the battery may be repeatedly cycled (i.e., charged and discharged) to near-zero-voltage conditions without significant decline in battery performance.

[0082] It is intended that a lithium-ion battery such as that described herein may be fully discharged while the materials for both electrodes, including their corresponding current collectors, are stable (e.g., corrosion of the current collectors and/or the decomposition of active material may be avoided, etc.). One potential advantageous feature of such an arrangement is that the occurrence of reduced device functionality (i.e., the need to recharge more frequently) and corrosion of the current collectors and battery case (with the incumbent possibility of leaking potentially corrosive and toxic battery contents) may be reduced or avoided.

[0083] While the auxiliary electrode 260 has been described with respect to being selectively electrically connected or coupled to the negative electrode 220, according to another exemplary embodiment, an auxiliary electrode may be provided such that it may be selectively electrically connected or coupled to a positive electrode. FIGURES 9-13 show various views of a battery 600 having a case 602 including a positive electrode 610, a negative electrode 620, and an auxiliary electrode 660 selectively electrically coupled or connected to the positive electrode (e.g., by a switch 670, and according to another exemplary embodiment, according to a diode or other device). Also, it should be noted that

one of the positive electrode 610 and negative electrode 620 may be coupled to the case 602 (e.g., as opposed to being electrically isolated from the case) according to other exemplary embodiments. The auxiliary electrode 660, while being shown in the headspace of the battery 600, may be provided in other locations as may be desired. The various components shown in FIGURES 9-13 include reference numerals similar to those shown in FIGURES 3-7, with the reference numerals in FIGURES 9-13 being 400 away from the reference numerals shown in FIGURES 2-7 (e.g., negative electrode 220 shown in FIGURE 4 corresponds to negative electrode 620 shown in FIGURE 10).

[0084] FIGURES 10-11 show exemplary schematic views of configurations for exemplary embodiments in which an auxiliary electrode 660 is selectively electrically coupled to a positive electrode 610. Such configurations are similar to those shown in FIGURES 4-5, with FIGURE 10 representing the use of a diode 662 and FIGURE 11 representing the use of a control circuit 664 which operates to close a switch 670 to electrically connect the auxiliary electrode 660 to the positive electrode 610. As shown in FIGURES 12-13, a switch 670 is provided which electrically connects the positive electrode 610 to the auxiliary electrode 660 external to the battery 600. The auxiliary electrode 660 is electrically isolated (using a separator 665) from both the positive electrode 610 and the negative electrode 620, and an electrolyte 667 may be provided. It should be noted that while FIGURES 12 and 13 show the auxiliary electrode as being adjacent to the negative electrode, the auxiliary electrode may be provided adjacent the positive electrode according to another exemplary embodiment. The various materials used for the components of the battery 600 may be identical to those described with respect to the battery 200.

[0085] The active material 663 provided on the current collector 661 of the auxiliary electrode 660 may be formed from a material similar to those described above, with the provision that such materials must be provided in their oxidized (i.e., de-lithiated) form. That is to say, the auxiliary electrode does not include an active material that utilizes lithium according to an exemplary embodiment in which the auxiliary electrode is configured for selective coupling and decoupling from the positive electrode. Further, it should be noted that according to an exemplary embodiment in which the auxiliary electrode is configured for selective coupling and decoupling from the positive electrode, the active material provided on the negative current collector must include lithium or be provided with a source of lithium (e.g., powdered lithium, a lithium patch, etc.) sufficient to compensate at

minimum for the loss of lithium due to the formation of an SEI during initial charging (see, e.g., FIGURES 12, in which a powdered lithium material is provided, and FIGURE 13, in which a lithium patch is provided on the negative electrode).

[0086] It may be advantageous to provide a battery such as that shown as battery 600 in FIGURES 9-13 for a variety of reasons. For example, the active material 663 provided on the current collector 661 of the auxiliary electrode 660 may prevent the positive electrode from being pulled below its decomposition potential in a fully discharged cell (e.g., it may prevent decomposition of the active material 614 provided on the current collector 612 of the positive electrode 610). This may protect the positive electrode in situations where, for example, the negative electrode (e.g., a carbon electrode) is pre-lithiated using the lithium patch in order to protect its potential from being pulled above the corrosion potential of the negative current collector 622 of the negative electrode 620. It may also be advantageous to provide a battery having an arrangement such as that shown in FIGURES 9-13 in the event that the active material applied to the auxiliary electrode is not stable (i.e., becomes oxidized) at the maximum potential of the positive electrode in a fully charged cell. In contrast, in situations in which the secondary active material is stable (i.e., does not become oxidized at the maximum potential of the positive electrode in a fully charged cell), it could be directly added to the positive electrode material.

[0087] Various advantageous features may be obtained by utilizing batteries such as those shown and described herein. For example, use of such batteries may eliminate the need to utilize circuitry to disconnect batteries approaching near-zero voltage conditions. By not utilizing circuitry for this function, volume and cost reductions may be obtained.

[0088] According to an exemplary embodiment, lithium-ion batteries such as those described above may be used in conjunction with medical devices such as medical devices that may be implanted in the human body (referred to as “implantable medical devices” or “IMD’s”).

[0089] FIGURE 14 illustrates a schematic view of a system 400 (e.g., an implantable medical device) implanted within a body or torso 432 of a patient 430. The system 400 includes a device 410 in the form of an implantable medical device that for purposes of illustration is shown as a defibrillator configured to provide a therapeutic high voltage (e.g., 700 volt) treatment for the patient 430.

[0090] The device 410 includes a container or housing 414 that is hermetically sealed and biologically inert according to an exemplary embodiment. The container may be made of a conductive material. One or more leads 416 electrically connect the device 410 and to the patient's heart 420 via a vein 422. Electrodes 417 are provided to sense cardiac activity and/or provide an electrical potential to the heart 420. At least a portion of the leads 416 (e.g., an end portion of the leads shown as exposed electrodes 417) may be provided adjacent or in contact with one or more of a ventricle and an atrium of the heart 420.

[0091] The device 410 includes a battery 440 provided therein to provide power for the device 410. According to another exemplary embodiment, the battery 440 may be provided external to the device or external to the patient 430 (e.g., to allow for removal and replacement and/or charging of the battery). The size and capacity of the battery 440 may be chosen based on a number of factors, including the amount of charge required for a given patient's physical or medical characteristics, the size or configuration of the device, and any of a variety of other factors. According to an exemplary embodiment, the battery is a 500 mAh battery. According to another exemplary embodiment, the battery is a 300 mAh battery. According to various other exemplary embodiments, the battery may have a capacity of between approximately 10 and 1000 mAh.

[0092] According to other exemplary embodiments, more than one battery may be provided to power the device 410. In such exemplary embodiments, the batteries may have the same capacity or one or more of the batteries may have a higher or lower capacity than the other battery or batteries. For example, according to an exemplary embodiment, one of the batteries may have a capacity of approximately 500 mAh while another of the batteries may have a capacity of approximately 75 mAh.

[0093] One or more capacitors (shown as capacitor bank 450) are provided in the device to store energy provided by the battery 440. For example, the system 410 may be configured such that when the device 410 determines that a therapeutic high-voltage treatment is required to establish a normal sinus rhythm for the heart 420, the capacitors in the capacitor bank 450 are charged to a predetermined charge level by the battery 440. Charge stored in the capacitors may then be discharged via the leads 416 to the heart 420. According to another exemplary embodiment, the capacitors may be charged prior to

determination that a stimulating charge is required by the heart such that the capacitors may be discharged as needed.

[0094] According to another exemplary embodiment shown in FIGURE 8, an implantable neurological stimulation device 500 (an implantable neuro stimulator or INS) may include a battery 502 such as those described above with respect to the various exemplary embodiments. Examples of other neuro stimulation products and related components are shown and described in a brochure titled "Implantable Neurostimulation Systems" available from Medtronic, Inc.

[0095] An INS generates one or more electrical stimulation signals that are used to influence the human nervous system or organs. Electrical contacts carried on the distal end of a lead are placed at the desired stimulation site such as the spine or brain and the proximal end of the lead is connected to the INS. The INS is then surgically implanted into an individual such as into a subcutaneous pocket in the abdomen, pectoral region, or upper buttocks area. A clinician programs the INS with a therapy using a programmer. The therapy configures parameters of the stimulation signal for the specific patient's therapy. An INS can be used to treat conditions such as pain, incontinence, movement disorders such as epilepsy and Parkinson's disease, and sleep apnea. Additional therapies appear promising to treat a variety of physiological, psychological, and emotional conditions. Before an INS is implanted to deliver a therapy, an external screener that replicates some or all of the INS functions is typically connected to the patient to evaluate the efficacy of the proposed therapy.

[0096] The INS 500 includes a lead extension 522 and a stimulation lead 524. The stimulation lead 524 is one or more insulated electrical conductors with a connector 532 on the proximal end and electrical contacts (not shown) on the distal end. Some stimulation leads are designed to be inserted into a patient percutaneously, such as the Model 3487A Pisces-Quad[®] lead available from Medtronic, Inc. of Minneapolis Minn., and stimulation some leads are designed to be surgically implanted, such as the Model 3998 Specify[®] lead also available from Medtronic.

[0097] Although the lead connector 532 can be connected directly to the INS 500 (e.g., at a point 536), typically the lead connector 532 is connected to a lead extension 522. The

lead extension 522, such as a Model 7495 available from Medtronic, is then connected to the INS 500.

[0098] Implantation of an INS 520 typically begins with implantation of at least one stimulation lead 524, usually while the patient is under a local anesthetic. The stimulation lead 524 can either be percutaneously or surgically implanted. Once the stimulation lead 524 has been implanted and positioned, the stimulation lead's 524 distal end is typically anchored into position to minimize movement of the stimulation lead 524 after implantation. The stimulation lead's 524 proximal end can be configured to connect to a lead extension 522.

[0099] The INS 500 is programmed with a therapy and the therapy is often modified to optimize the therapy for the patient (i.e., the INS may be programmed with a plurality of programs or therapies such that an appropriate therapy may be administered in a given situation). In the event that the battery 502 requires recharging, an external lead (not shown) may be used to electrically couple the battery to a charging device or apparatus.

[0100] A physician programmer and a patient programmer (not shown) may also be provided to allow a physician or a patient to control the administration of various therapies. A physician programmer, also known as a console programmer, uses telemetry to communicate with the implanted INS 500, so a clinician can program and manage a patient's therapy stored in the INS 500, troubleshoot the patient's INS 500 system, and/or collect data. An example of a physician programmer is a Model 7432 Console Programmer available from Medtronic. A patient programmer also uses telemetry to communicate with the INS 500, so the patient can manage some aspects of her therapy as defined by the clinician. An example of a patient programmer is a Model 7434 Itrel[®] 3 EZ Patient Programmer available from Medtronic.

[0101] While the medical devices described herein (e.g., systems 400 and 500) are shown and described as a defibrillator and a neurological stimulation device, it should be appreciated that other types of implantable medical devices may be utilized according to other exemplary embodiments, such as pacemakers, cardiac contractility modulators, cardioverters, drug administering devices, diagnostic recorders, cochlear implants, and the like for alleviating the adverse effects of various health ailments. According to still other

embodiments, non-implantable medical devices or other types of devices may utilize batteries as are shown and described in this disclosure.

[0102] It is also contemplated that the medical devices described herein may be charged or recharged when the medical device is implanted within a patient. That is, according to an exemplary embodiment, there is no need to disconnect or remove the medical device from the patient in order to charge or recharge the medical device. For example, transcutaneous energy transfer (TET) may be used, in which magnetic induction is used to deliver energy from outside the body to the implanted battery, without the need to make direct physical contact to the implanted battery, and without the need for any portion of the implant to protrude from the patient's skin. According to an exemplary embodiment, a connector may be provided external to the patient's body that may be electrically coupled to a charging device in order to charge or recharge the battery. According to other exemplary embodiments, medical devices may be provided that may require removal or detachment from the patient in order to charge or recharge the battery.

[0103] It should be understood that while the present disclosure describes the use of lithium-ion batteries with a variety of medical devices, such batteries may be used in a variety of other applications, including computers (e.g., laptop computers), phones (e.g., cellular, mobile, or cordless phones), automobiles, and any other device or application for which it may be advantageous to provide power in the form of a lithium-ion battery.

[0104] It is also important to note that the construction and arrangement of the lithium-ion battery as shown and described with respect to the various exemplary embodiments is illustrative only. Although only a few embodiments of the present inventions have been described in detail in this disclosure, those skilled in the art who review this disclosure will readily appreciate that many modifications are possible (e.g., variations in sizes, dimensions, structures, shapes and proportions of the various elements, values of parameters, mounting arrangements, use of materials, colors, orientations, etc.) without materially departing from the novel teachings and advantages of the subject matter recited in the claims. Accordingly, all such modifications are intended to be included within the scope of the present invention as defined in the appended claims. Other substitutions, modifications, changes and omissions may be made in the design, operating conditions and

arrangement of the preferred and other exemplary embodiments without departing from the scope of the present invention as expressed in the appended claims.

WHAT IS CLAIMED IS:

- 1 1. A battery comprising:
2 a positive electrode comprising a current collector and a first active material;
3 a negative electrode comprising a current collector and a second active
4 material; and
5 an auxiliary electrode comprising a current collector and a third active
6 material, the auxiliary electrode configured for selective electrical connection to one of the
7 positive electrode and the negative electrode;
8 wherein the first active material, second active material, and third active
9 material are configured to allow doping and undoping of lithium ions; and
10 wherein the third active material exhibits charging and discharging capacity
11 below a corrosion potential of the current collector of the negative electrode and above a
12 decomposition potential of the first active material.
- 1 2. The battery as claimed in Claim 1, wherein the auxiliary electrode is
2 provided such that it is electrically isolated from the positive electrode and the negative
3 electrode within the battery.
- 1 3. The battery as claimed in Claim 1 or 2, wherein the auxiliary electrode is
2 configured to be selectively electrically connected to and disconnected from one of the
3 positive electrode and the negative electrode using a mechanism provided external to the
4 battery.
- 1 4. The battery as claimed in Claim 1 or 2, wherein the auxiliary electrode is
2 configured to be selectively electrically connected to and disconnected from one of the
3 positive electrode and the negative electrode using a diode.
- 1 5. The battery as claimed in Claim 4, wherein the battery is configured to
2 electrically connect the auxiliary electrode when the difference in potential between the
3 auxiliary electrode and one of the positive electrode and the negative electrode exceeds a
4 predetermined value.

1 6. The battery as claimed in Claim 1 or 2, wherein the auxiliary electrode is
2 configured to be selectively electrically connected to and disconnected from one of the
3 positive electrode and the negative electrode using a switch.

1 7. The battery as claimed in Claim 6, wherein the switch is configured to
2 selectively electrically connect the auxiliary electrode when the difference in voltage
3 between the positive electrode and the negative electrode falls below a predetermined value.

1 8. The battery as claimed in Claim 1 or 2, wherein the auxiliary electrode is
2 configured for selective electrical coupling to the negative electrode.

1 9. The battery as claimed in Claim 8, further comprising a source of lithium in
2 electrical contact with the auxiliary electrode.

1 10. The battery as claimed in Claim 8, wherein the third active material
2 comprises electrochemically active lithium.

1 11. The battery as claimed in Claim 10, wherein the third active material
2 comprises a material selected from the group consisting of LiMn_2O_4 , Li_xVO_2 , $\text{LiM}_x\text{Mn}_{(2-x)}\text{O}_4$
3 (where M is a metal), and combinations thereof.

1 12. The battery as claimed in Claim 1 or 2, wherein the auxiliary electrode is
2 configured for selective electrical connection to the positive electrode.

1 13. The battery as claimed in Claim 12, wherein the third active material does
2 not include electrochemically active lithium.

1 14. The battery as claimed in Claim 13, wherein second active material
2 comprises a lithium titanate material.

1 15. The battery as claimed in Claim 13, further comprising a source of lithium in
2 electrical contact with the negative electrode.

1 16. The battery as claimed in Claim 9 or 15, wherein the source of lithium
2 comprises at least one of a lithium patch and powdered lithium.

1 17. The battery as claimed in Claim 13, wherein the third active material
2 comprises a material selected from the group consisting of V_2O_5 , V_6O_{13} , V_3O_8 , MoO_3 , TiS_2 ,
3 WO_2 , MoO_2 , RuO_2 , and combinations thereof.

1 18. The battery as claimed in Claim 1 or 2, wherein the first active material
2 comprises a material selected from the group consisting of $LiCoO_2$, a material having the
3 form $LiCo_xNi_{(1-x)}O_2$, a material having the form $LiCo_xMn_yNi_zO_2$, and a material having the
4 form $LiNi_xCo_yAl_zO_2$.

1 19. The battery as claimed in any of the preceding Claims, wherein the battery
2 has a capacity between approximately 10 mAh and 1000 mAh.

1 20. The battery as claimed in Claim 1 or 2, wherein the first active material
2 comprises lithium.

1 21. The battery as claimed in Claim 1 or 2, wherein first active material
2 comprises a lithium titanate material.

1 22. The battery as claimed in Claim 1 or 2, wherein the current collector of the
2 negative electrode comprises copper or titanium.

1 23. The battery as claimed in any one of the preceding claims provided in a
2 medical device.

1 24. The battery as claimed in Claim 23, wherein at least a portion of the medical
2 device is configured for implantation into a body of a patient.

1 25. The battery as claimed in Claim 23 and 24, wherein the medical device is
2 selected from the group consisting of a cardiac defibrillator, a cardiac pacemaker, a cardiac
3 contractility modulator, a cardioverter, a drug administration device, a cochlear implant, a
4 hearing aid, a sensor, a telemetry device, and a diagnostic recorder.

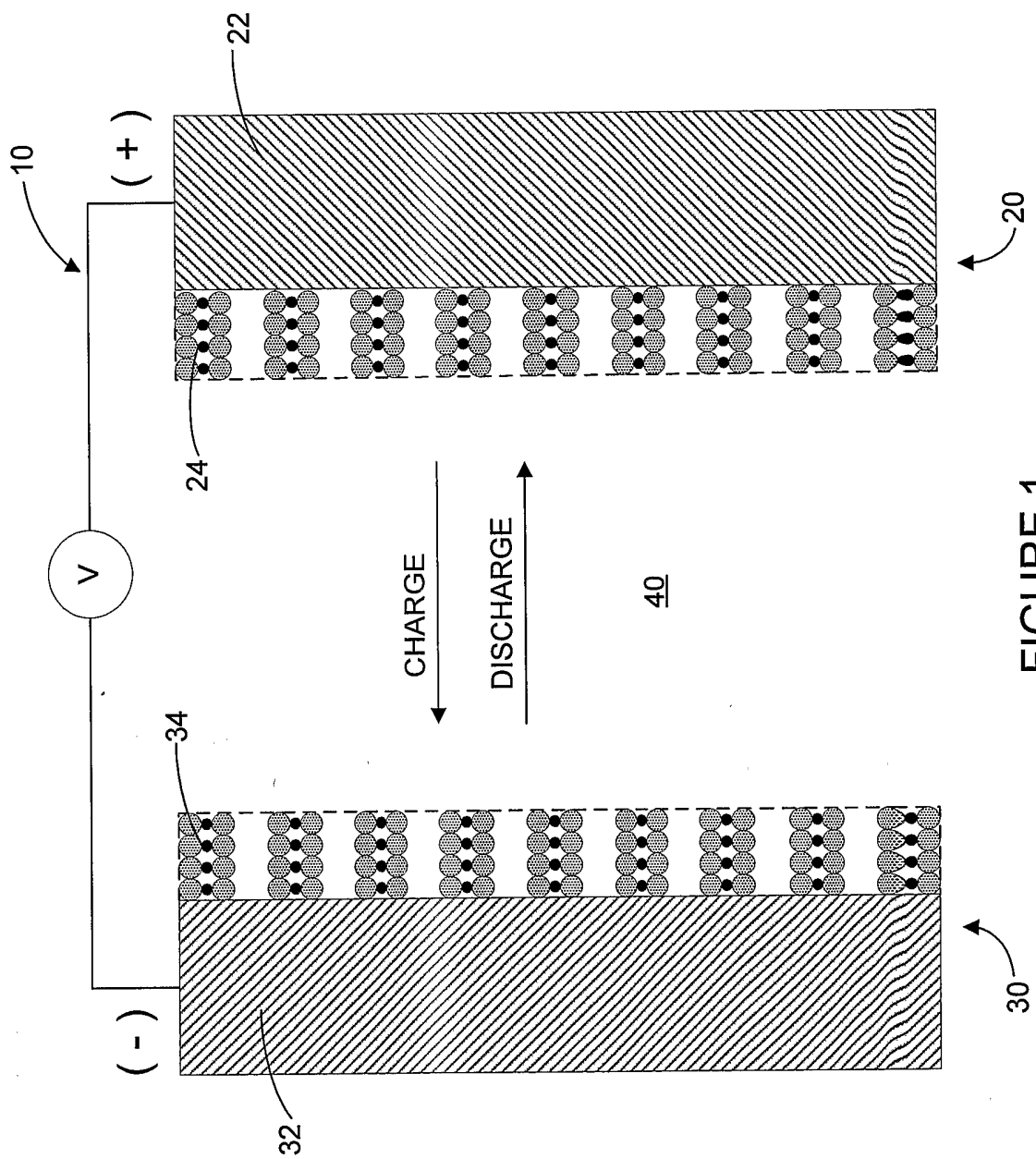

FIGURE 1

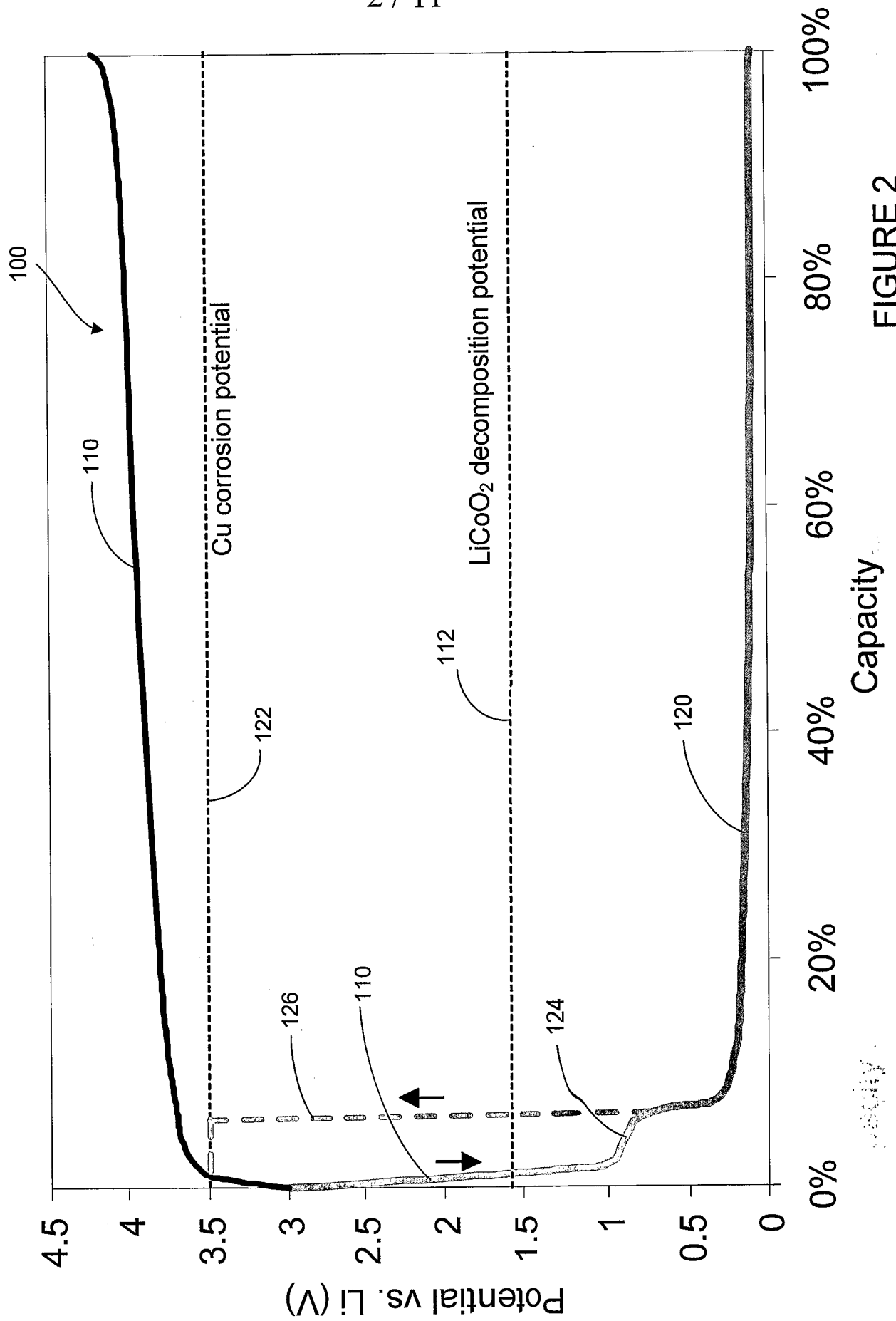

FIGURE 2

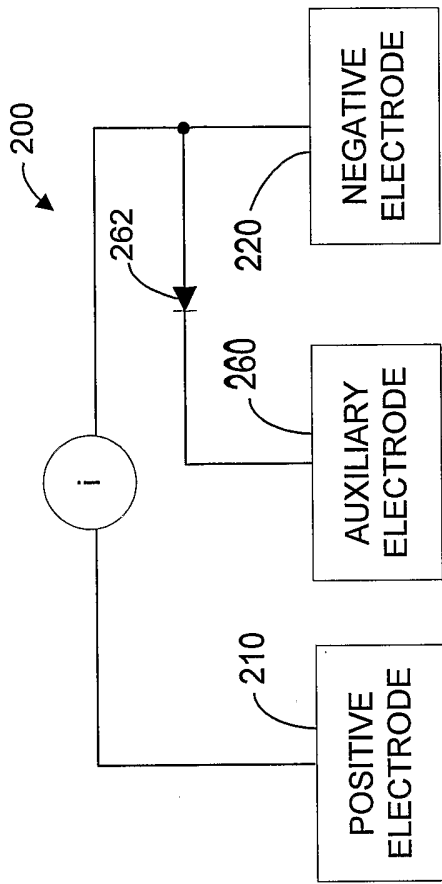

FIGURE 4

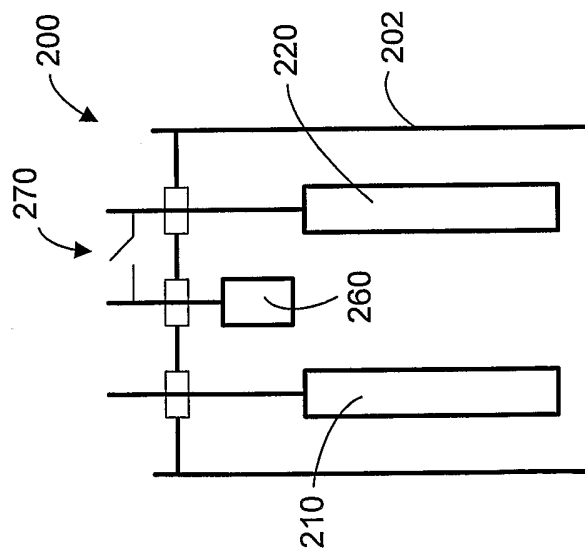

FIGURE 3

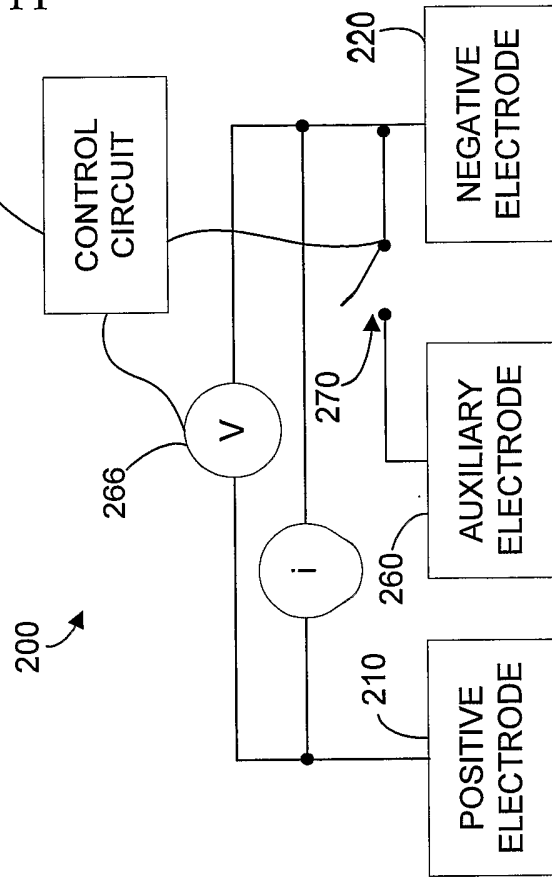

FIGURE 5

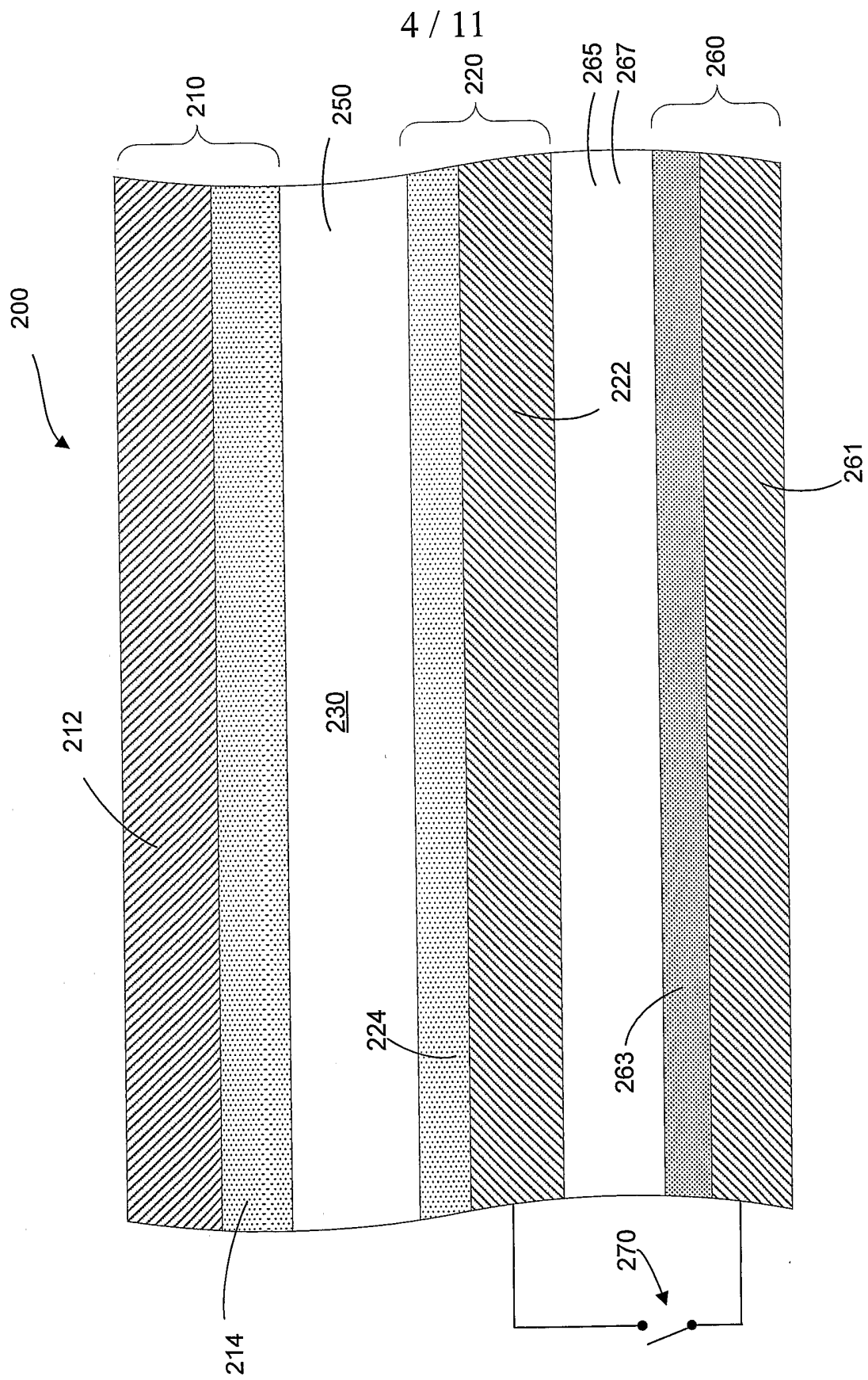

FIGURE 6

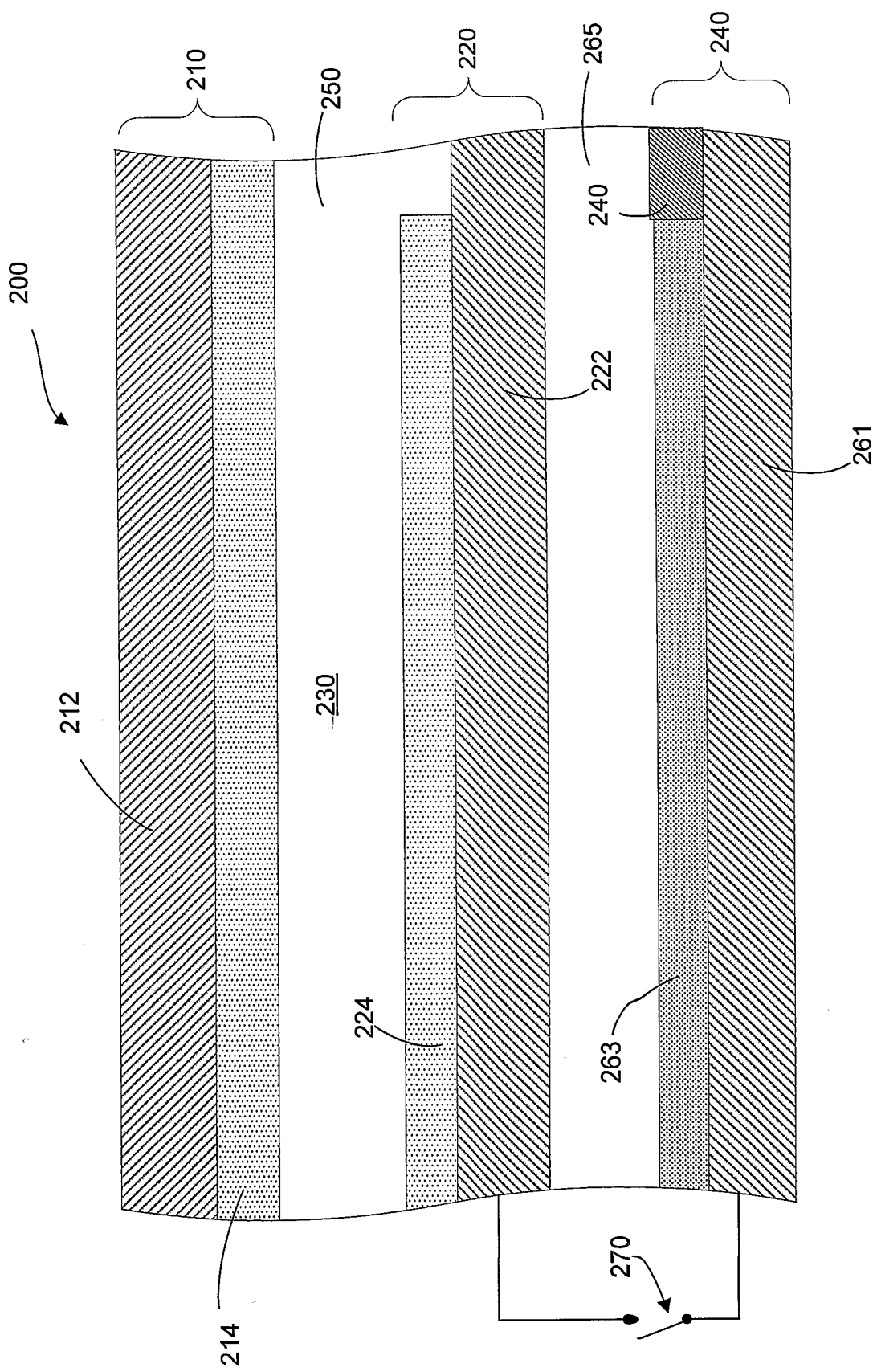

FIGURE 7

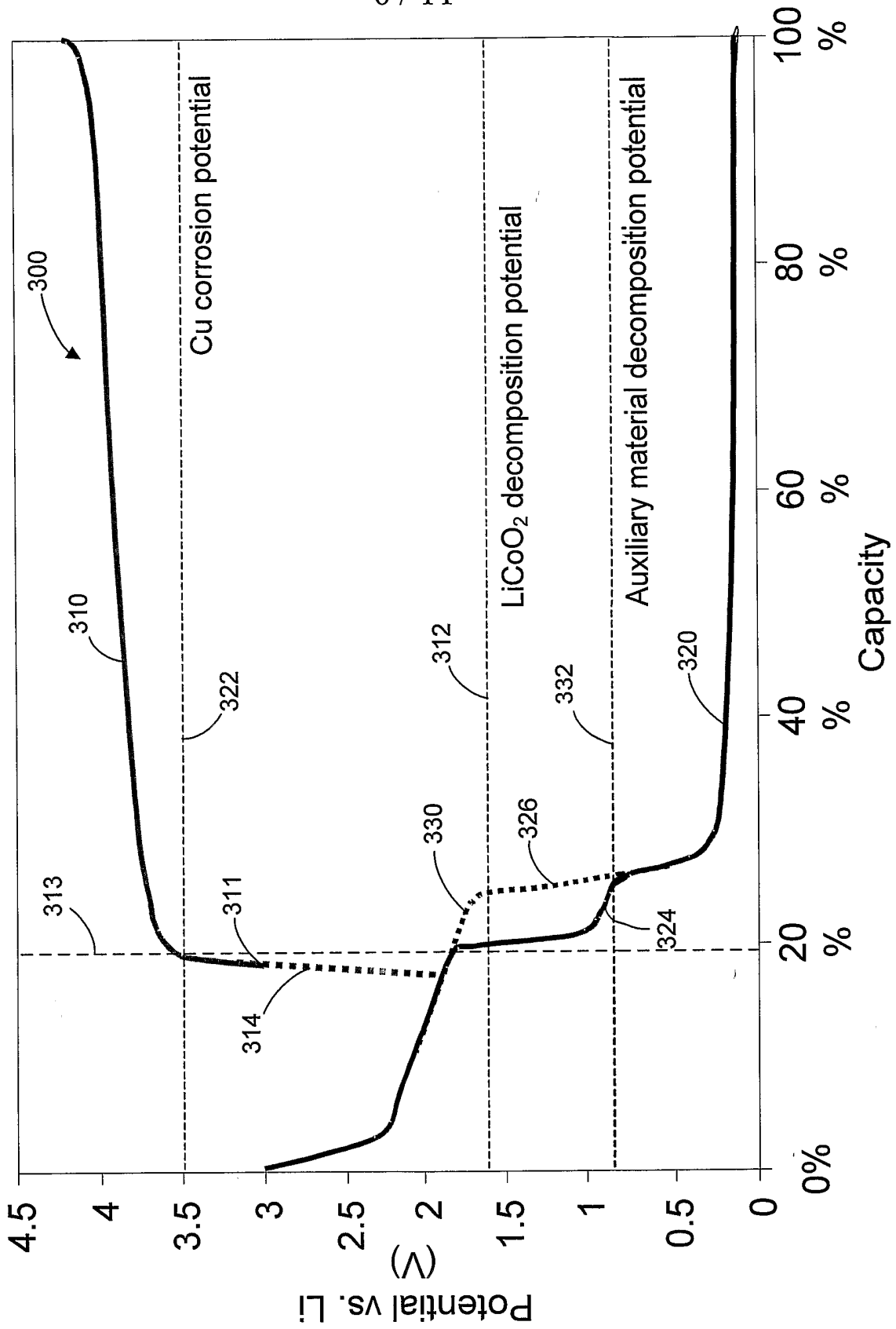

FIGURE 8

FIG 8

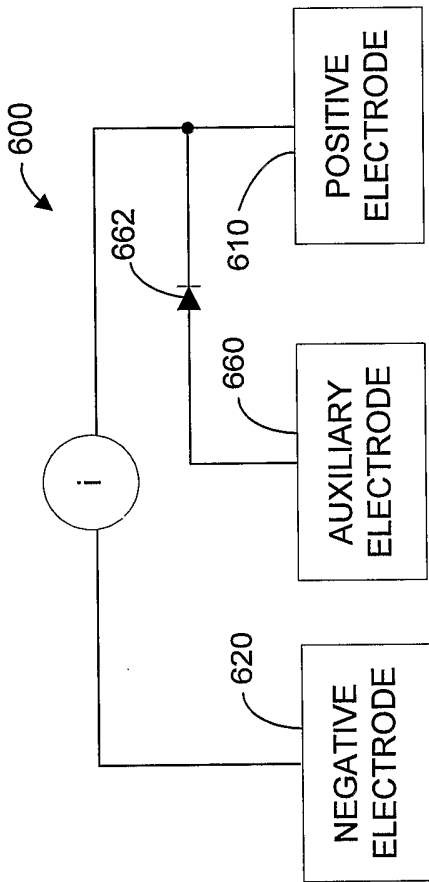

FIGURE 10

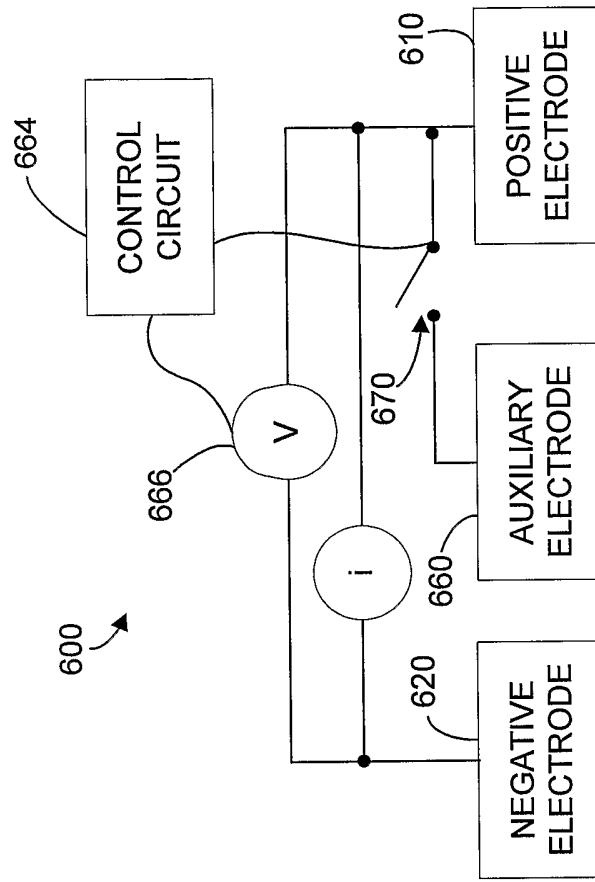

FIGURE 11

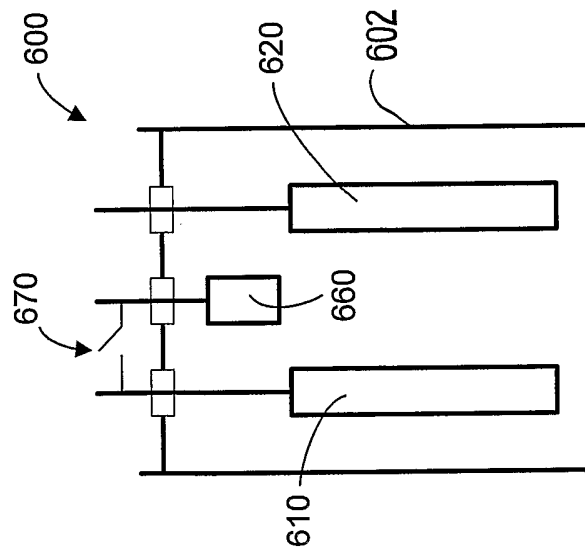

FIGURE 9

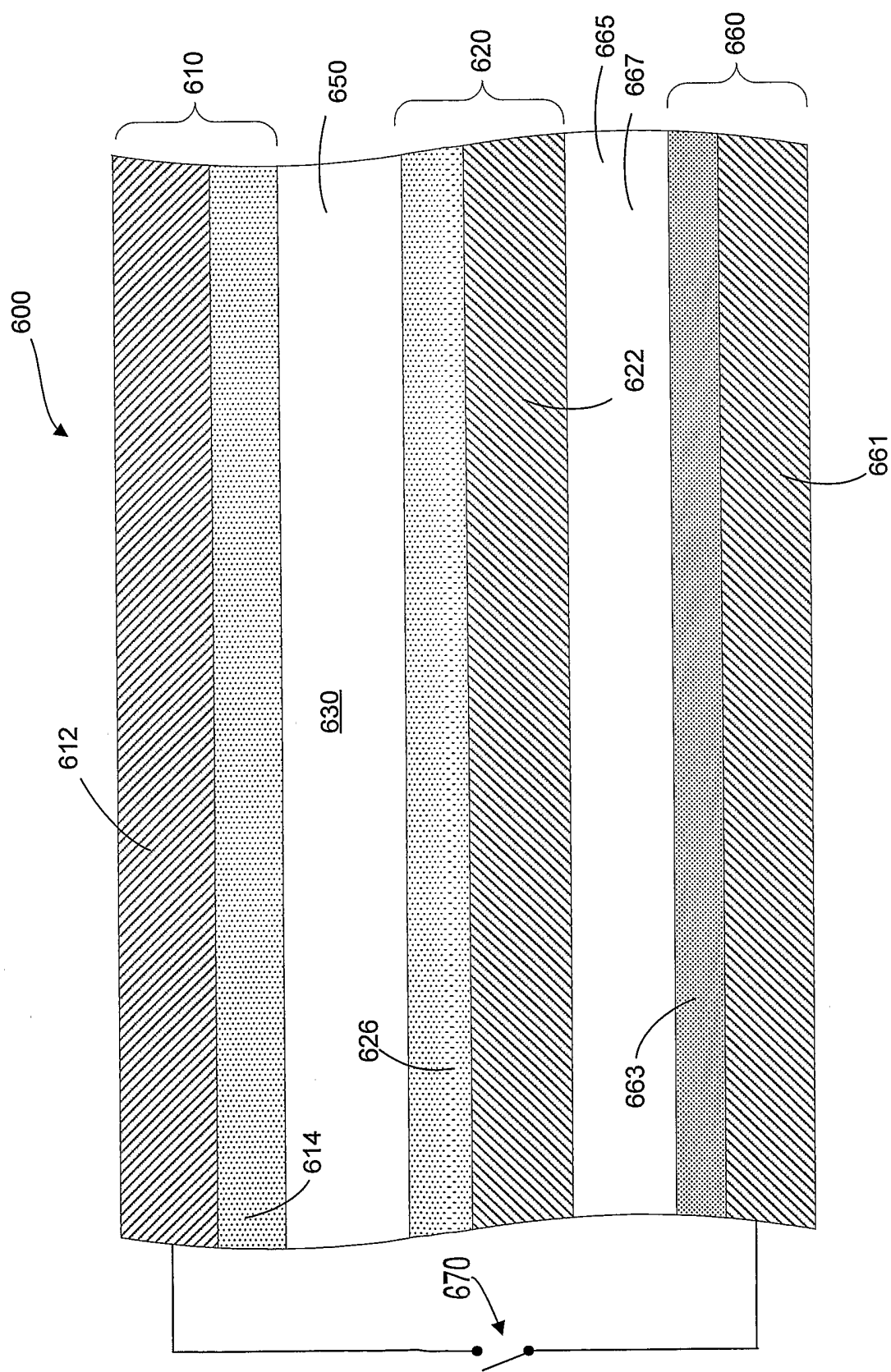

FIGURE 12

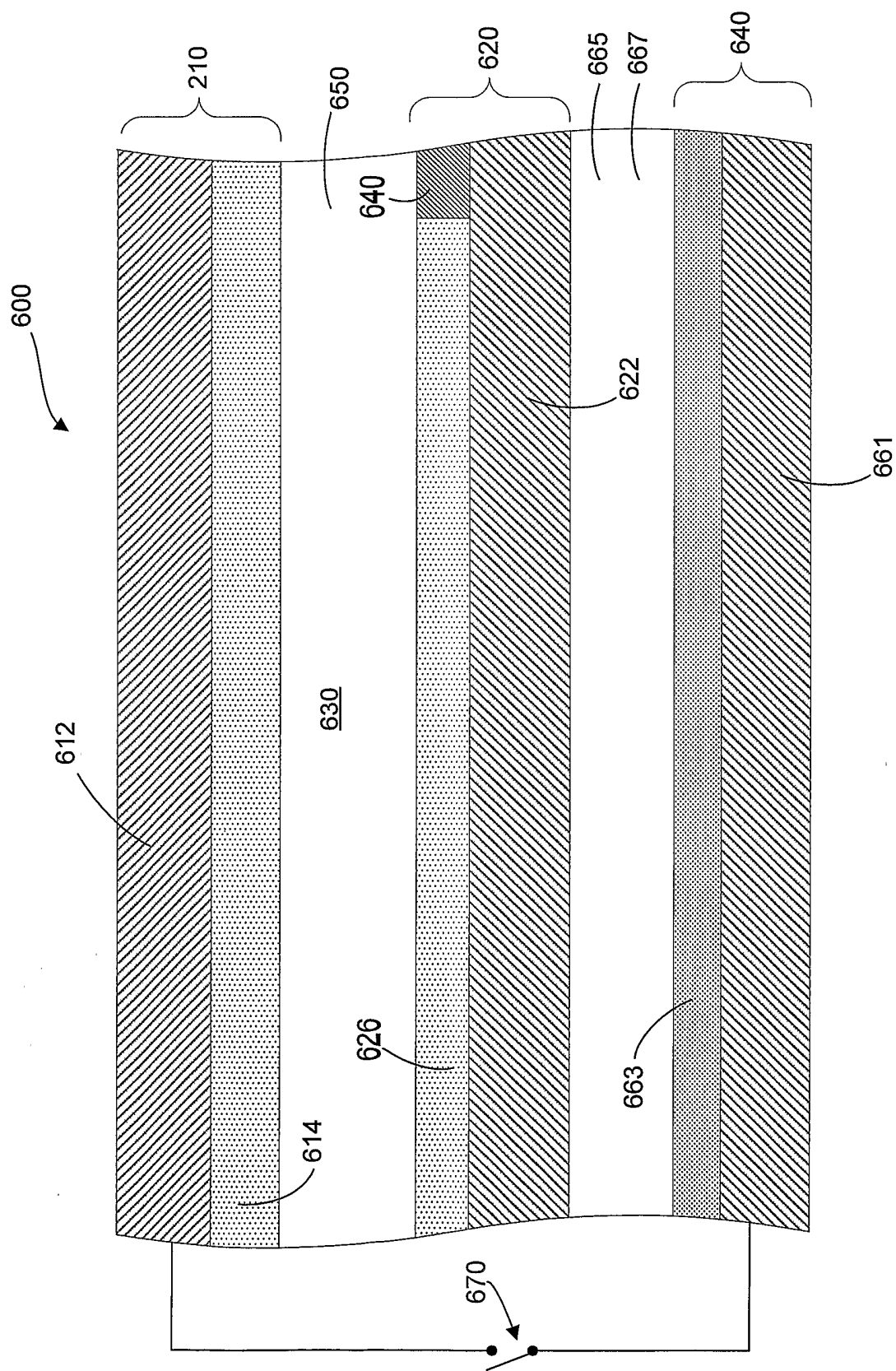

FIGURE 13

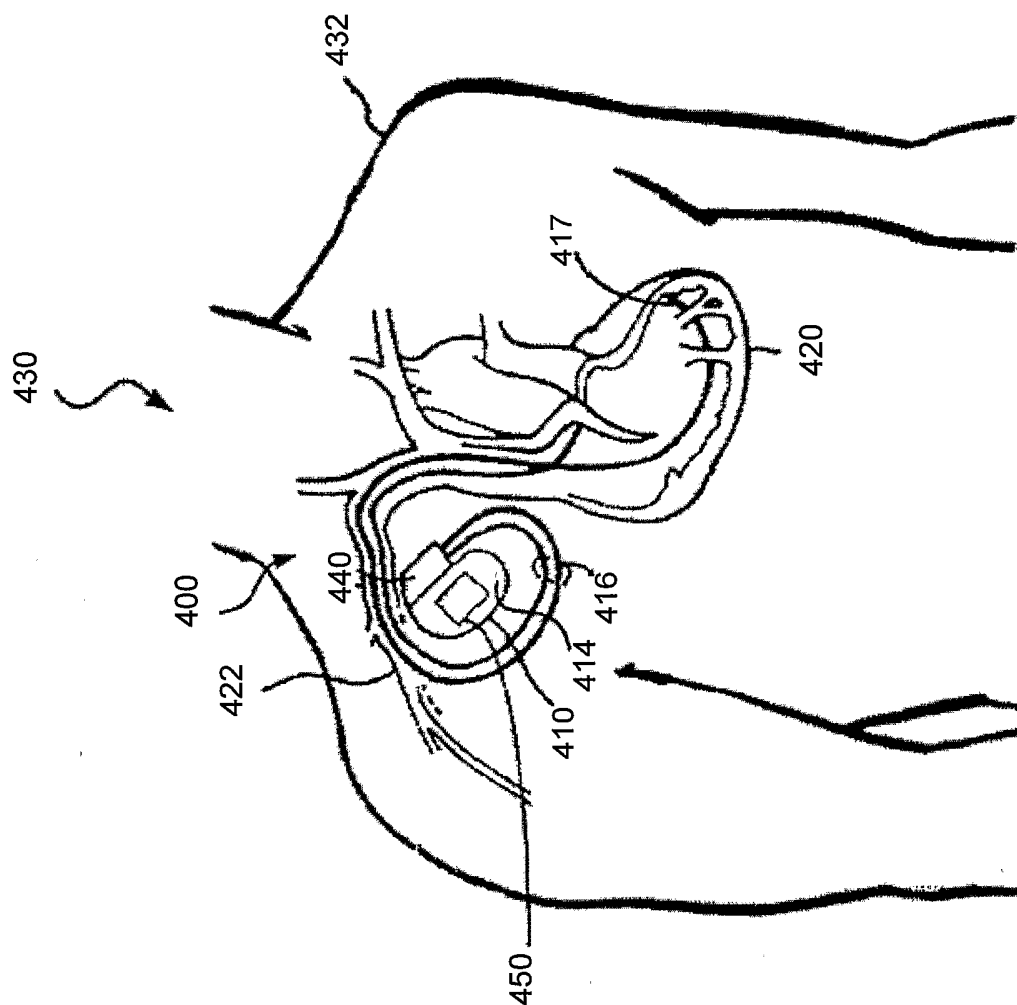

FIGURE 14

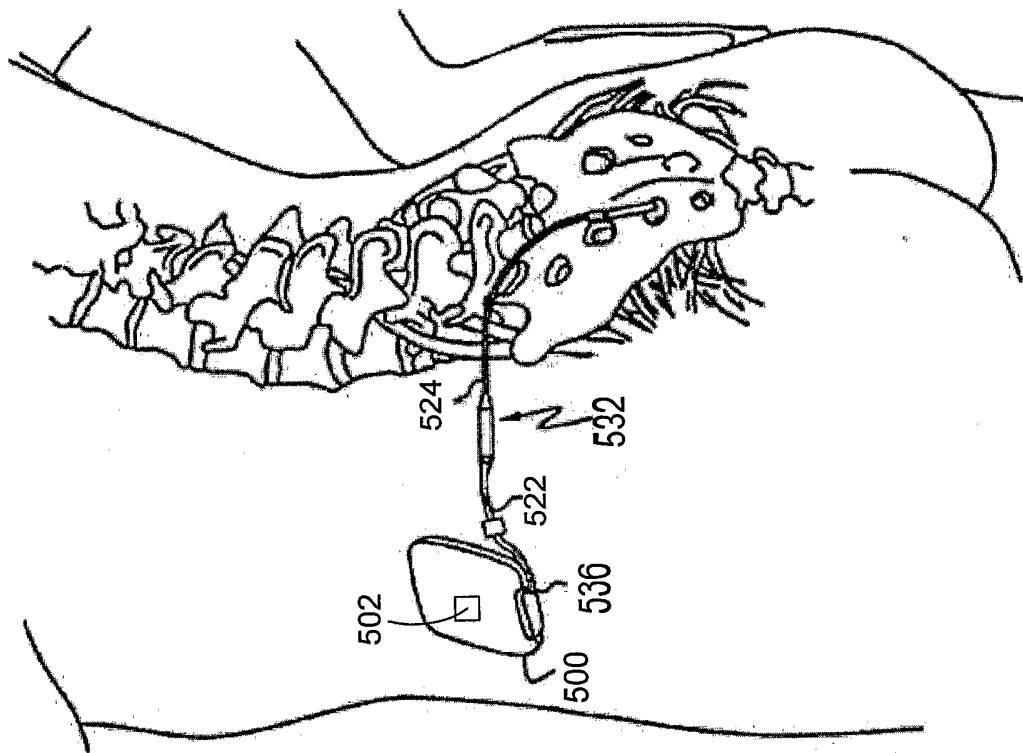

FIGURE 15