

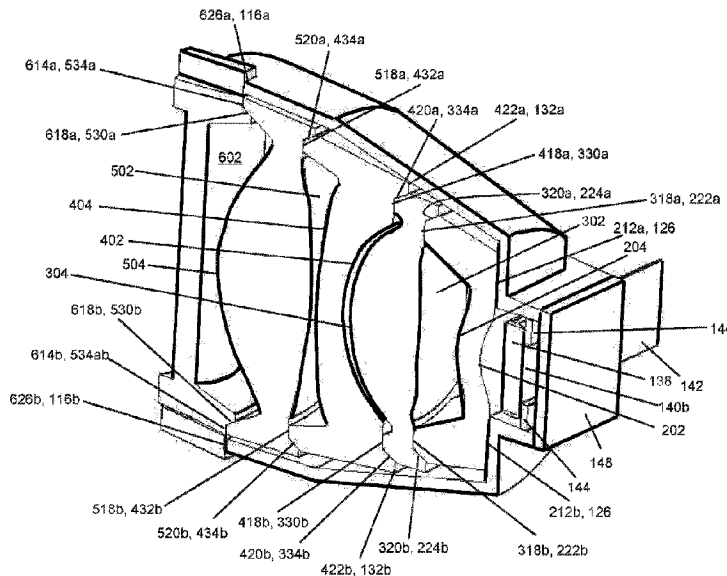

(86) Date de dépôt PCT/PCT Filing Date: 2020/12/06  
 (87) Date publication PCT/PCT Publication Date: 2021/06/17  
 (45) Date de délivrance/Issue Date: 2023/02/14  
 (85) Entrée phase nationale/National Entry: 2022/03/22  
 (86) N° demande PCT/PCT Application No.: IL 2020/051259  
 (87) N° publication PCT/PCT Publication No.: 2021/117033  
 (30) Priorité/Priority: 2019/12/08 (US62/945,165)

(51) Cl.Int./Int.Cl. *G02B 27/01* (2006.01),  
*G02B 27/00* (2006.01), *G02B 6/10* (2006.01),  
*H04N 9/12* (2006.01)  
 (72) Inventeurs/Inventors:  
 GREENSTEIN, KOBI, IL;  
 EISENFELD, TSION, IL;  
 GOLDSTEIN, NETANEL, IL  
 (73) Propriétaire/Owner:  
 LUMUS LTD., IL  
 (74) Agent: INTEGRAL IP

(54) Titre : SYSTEME OPTIQUE AVEC PROJECTEUR D'IMAGE COMPACT  
 (54) Title: OPTICAL SYSTEMS WITH COMPACT IMAGE PROJECTOR



(57) **Abrégé/Abstract:**

An optical system has a hollow mechanical body having first and second ends. An optical assembly has a plurality of optical components arranged in a stack configuration. Each of the optical components has a set of engagement configurations. For each pair of adjacent optical components in the stack configuration, at least some of the engagement configurations of a first optical component in the pair engage with at least some of the engagement configurations of a second optical component in the pair. Some of the engagement configurations of the optical component at a first end of the stack configuration engage with corresponding engagement configurations of the hollow mechanical body at the first end of the hollow mechanical body to position the other optical components of the stack configuration within the hollow mechanical body. An emissive display device is deployed at the second end of the hollow mechanical body.

(12) INTERNATIONAL APPLICATION PUBLISHED UNDER THE PATENT COOPERATION TREATY (PCT)

(19) World Intellectual Property Organization  
International Bureau

(43) International Publication Date  
17 June 2021 (17.06.2021)



(10) International Publication Number  
**WO 2021/117033 A1**

(51) International Patent Classification:

G02B 27/01 (2006.01) H04N 9/12 (2006.01)  
G02B 27/00 (2006.01) G02B 6/10 (2006.01)

(21) International Application Number:

PCT/IL2020/051259

(22) International Filing Date:

06 December 2020 (06.12.2020)

(25) Filing Language:

English

(26) Publication Language:

English

(30) Priority Data:

62/945,165 08 December 2019 (08.12.2019) US

(71) Applicant: LUMUS LTD. [IL/IL]; 8 Pinhas Sapir Street, 7403631 Ness Ziona (IL).

(72) Inventors: GREENSTEIN, Kobi; 8 Pinhas Sapir Street, 7403631 Ness Ziona (IL). EISENFELD, Tsion; Harav Norok Street 10/32, 7835515 Ashkelon (IL). GOLDSTEIN, Netanel; 8 Pinhas Sapir Street, 7403631 Ness Ziona (IL).

(74) Agent: FRIEDMAN, Mark; 7 Jabotinsky St., Moshe Aviv Tower, 54th Floor, 5252007 Ramat Gan (IL).

(81) Designated States (unless otherwise indicated, for every kind of national protection available): AE, AG, AL, AM, AO, AT, AU, AZ, BA, BB, BG, BH, BN, BR, BW, BY, BZ, CA, CH, CL, CN, CO, CR, CU, CZ, DE, DJ, DK, DM, DO, DZ, EC, EE, EG, ES, FI, GB, GD, GE, GH, GM, GT, HN, HR, HU, ID, IL, IN, IR, IS, IT, JO, JP, KE, KG, KH, KN, KP, KR, KW, KZ, LA, LC, LK, LR, LS, LU, LY, MA, MD, ME, MG, MK, MN, MW, MX, MY, MZ, NA, NG, NI, NO, NZ, OM, PA, PE, PG, PH, PL, PT, QA, RO, RS, RU, RW,

(54) Title: OPTICAL SYSTEMS WITH COMPACT IMAGE PROJECTOR

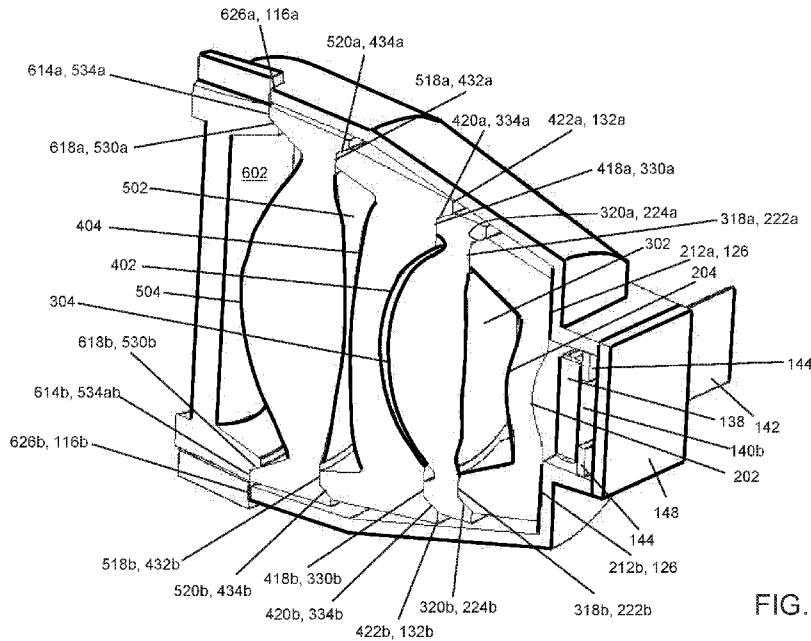

FIG. 15

(57) Abstract: An optical system has a hollow mechanical body having first and second ends. An optical assembly has a plurality of optical components arranged in a stack configuration. Each of the optical components has a set of engagement configurations. For each pair of adjacent optical components in the stack configuration, at least some of the engagement configurations of a first optical component in the pair engage with at least some of the engagement configurations of a second optical component in the pair. Some of the engagement configurations of the optical component at a first end of the stack configuration engage with corresponding engagement configurations of the hollow mechanical body at the first end of the hollow mechanical body to position the other optical components of the stack configuration within the hollow mechanical body. An emissive display device is deployed at the second end of the hollow mechanical body.



WO 2021/117033 A1

**WO 2021/117033 A1** 

SA, SC, SD, SE, SG, SK, SL, ST, SV, SY, TH, TJ, TM, TN,  
TR, TT, TZ, UA, UG, US, UZ, VC, VN, WS, ZA, ZM, ZW.

- (84) Designated States** (*unless otherwise indicated, for every kind of regional protection available*): ARIPO (BW, GH, GM, KE, LR, LS, MW, MZ, NA, RW, SD, SL, ST, SZ, TZ, UG, ZM, ZW), Eurasian (AM, AZ, BY, KG, KZ, RU, TJ, TM), European (AL, AT, BE, BG, CH, CY, CZ, DE, DK, EE, ES, FI, FR, GB, GR, HR, HU, IE, IS, IT, LT, LU, LV, MC, MK, MT, NL, NO, PL, PT, RO, RS, SE, SI, SK, SM, TR), OAPI (BF, BJ, CF, CG, CI, CM, GA, GN, GQ, GW, KM, ML, MR, NE, SN, TD, TG).

**Declarations under Rule 4.17:**

- *of inventorship (Rule 4.17(iv))*

**Published:**

- *with international search report (Art. 21(3))*
- *before the expiration of the time limit for amending the claims and to be republished in the event of receipt of amendments (Rule 48.2(h))*

## Optical Systems with Compact Image Projector

5

This application claims priority from US Provisional Patent Application No. 62/945,165 filed December 8, 2019

### TECHNICAL FIELD

The present invention relates to optical system and devices having image projectors and aperture expanding optical waveguides.

10

### BACKGROUND OF THE INVENTION

Optical arrangements for near eye display (NED), head mounted display (HMD) and head up display (HUD) require large aperture to cover the area where the observer's eye is located (commonly referred to as the eye motion box – or EMB). In order to implement a compact device, the image that is to be projected into the observer's eye is generated by a small optical image generator (projector) having a small aperture that is multiplied to generate a large aperture.

15

An approach to aperture multiplication in one dimension has been developed based on a parallel-faced slab of transparent material within which the image propagates by internal reflection. Part of the image wavefront is coupled out of the slab, either by use of obliquely angled partial reflectors or by use of a diffractive optical element on one surface of the slab. Such a slab is referred herein as a light-guide optical element (LOE), light-guide substrate, light-transmitting substrate, or waveguide. The principles of such aperture multiplication are illustrated schematically in FIG. 1, which shows a light-guide optical element **10** having a pair of parallel major external surfaces (faces) **12a**, **12b** for guiding light by internal reflection (preferably total internal reflection). An image projector **11** (represented schematically as a rectangle) generates a projected image **14**, as represented here schematically by a beam of illumination **14** including sample rays **14a** and **14b** which span the beam. The projected image **14** is coupled into the light-guide optical element **10** by an optical coupling-in configuration **16**, as illustrated here schematically by a prism **16** (referred to interchangeably as a “wedge”), so as to generate reflected rays **18** which are trapped by internal reflection within the substrate, generating also rays **20**. Here, the wedge **16** includes three major surfaces **17a**, **17b** and **17c**,

20

25

30

where the surface **17c** is located next to (or is common with) a slant edge **15** of the LOE **10** (where the edge **15** is at an oblique angle  $\alpha_{\text{edge}}$  to the faces **12a**, **12b**). The image **14** enters the wedge **16** through the surface **17a**, and is then coupled into the LOE **10** via the surfaces **17c** and **15**.

5           The coupled-in image propagates along the substrate **10** by repeated internal reflection from the faces **12a**, **12b**, impinging on an optical coupling-out configuration **22**, as illustrated here schematically by a sequence of partially reflecting surfaces **22** at an oblique angle ( $\alpha_{\text{sur}}$ ) to the parallel faces **12a**, **12b**, where part of the image intensity is reflected so as to be coupled out of the substrate as rays **24a** and **24b** toward the pupil **25** of eye **26** of an observer that is located  
10 in the EMB **28** at a an eye relief (ER) distance **30** from the surface **12b**. In order to minimize unwanted reflections which might give rise to ghost images, the partially reflecting surfaces **22** are preferably coated so as to have low reflectance for a first range of incident angles, while having the desired partial reflectivity for a second range of incident angles, where a ray with a small inclination to the normal to a partially reflective surface **22** (represented here as angle  $\beta_{\text{ref}}$ )  
15 is split in order to generate a reflected ray for coupling out, while a high inclination (to the normal) ray is transmitted with negligible reflection.

The projected image **14** is a collimated image, i.e., where each pixel is represented by a beam of parallel rays at a corresponding angle, equivalent to light from a scene far from the observer (the collimated image is referred to as being “collimated to infinity”). The image is  
20 represented here simplistically by rays corresponding to a single point in the image, typically a centroid of the image, but in fact includes a range of angles to each side of this central beam, which are coupled in to the substrate with a corresponding range of angles, and similarly coupled out at corresponding angles, thereby creating a field of view corresponding to parts of the image arriving in different directions to the eye **26** of the observer.

25           Several previously contemplated optical architectures employ image projectors that utilize microdisplays implemented as reflective-display devices or transmissive-display devices that emit polarized light in response to polarized illumination (such as liquid crystal on silicon – LCoS, and liquid crystal displays – LCD) in combination with a wedge coupling-in configuration. These optical architectures enable filling of the LOE with light waves from the  
30 image projector covering a large field of view (FOV), as the angle between the image projector and the LOE is generally determined by the wedge and can be designed to enable filling of the LOE (in FIG. 1 this angle is the angle between the surface **12a**, **12b** and the normal to the surface **17a**). However, image projectors that employ reflective-display devices (e.g., LCoS) or transmissive-display devices (e.g., LCD) require illumination components for illuminating the

display device with polarized illumination in order to generate the polarized image light waves, and optical components for directing the polarized illumination to the display device and for outputting the polarized image illumination (and in certain cases depolarizing the polarized image illumination) for injection into the LOE. The illumination components include, for example, one or more LEDs, laser-diodes, beam combiners, optical fibers, and the like. The optical components include, for example, one or more polarization selective beamsplitters, polarizers, collimating optics coupled to polarization selective beamsplitters. These illumination components and optical components typically have a relatively high manufacturing cost, and also result in a heavier and bulkier image projector and overall optical system, which may be undesirable in situations in which the optical system is deployed as part of a near eye display (NED) device or head mounted display (HMD) device, in particular when the optical system is implemented in an eye-glasses form factor. In addition, use of wedge-type optical coupling-in configurations together with image projectors that utilize emissive-display devices may introduce ghost images and/or chromatic aberrations, thereby reducing the quality of the image that is coupled out of the LOE.

#### SUMMARY OF THE INVENTION

The present invention is an optical system having a light-guide optical element and a compact image projector, and a method for constructing the compact image projector. Certain preferred embodiments according to one aspect of the present invention provide a compact and lightweight image projector by utilizing an emissive-display device together with optical components arranged in a stack within a hollow mechanical body (i.e., a housing). The optical components are preferably manufactured in plastic, glass or polymer material by utilizing specially designed molds and using, for example, casting, injection molding techniques, or any other relevant molding process. The molds used to manufacture the optical components define engagement configurations of the optical components which promote a mechanical interlocking engagement between adjacent optical components of the stack. Other embodiments according to another aspect of the present invention provide optical coupling-in configurations that reduce the ghost images in the image that is output by the optical system. In yet another aspect of the present invention, ghost images that may arise from components of image projector are reduced by modifying the sidewalls of the optical components (and/or the mechanical body that houses/retains the optical components) of the image projector. Further embodiments according to yet another aspect of the present invention provide an image projector that includes an optical component that compensates for effects of chromatic aberration introduced by the light-guide optical element and/or the optical coupling-in configuration.

According to the teachings of an embodiment of the present invention, there is provided an optical system. The optical system comprises: a hollow mechanical body including first and second ends; an optical assembly including a plurality of optical components arranged in a stack configuration, each of the optical components including a set of engagement configurations, and  
5 for each pair of adjacent optical components in the stack configuration at least some of the engagement configurations of a first optical component in the pair are configured to engage with at least some of the engagement configurations of a second optical component in the pair, and some of the engagement configurations of the optical component at a first end of the stack configuration are configured to engage with corresponding engagement configurations of the  
10 hollow mechanical body at the first end of the hollow mechanical body so as to position the other optical components of the stack configuration within the hollow mechanical body; and an emissive display device deployed at the second end of the hollow mechanical body.

Optionally, the engagement configurations of the optical component at the first end of the stack configuration includes at least a pair of outwardly projecting flanges, and the engagement  
15 configurations at the first end of the hollow mechanical body includes a pair of channels configured to receive the projecting flanges.

Optionally, the hollow mechanical body further includes an inner sidewall configuration, and at least one of the optical components includes at least one rotation limiting configuration, and the rotation limiting configuration and the inner sidewall configuration cooperate to limit an  
20 amount of rotation of the optical assembly about one or more rotational axes.

Optionally, the second end of the hollow mechanical body includes: a receiving portion for receiving the emissive display device, and an outwardly projecting sidewall configuration.

Optionally, the optical system further comprises: a cover member deployed at the outwardly projecting sidewall configuration of the second end of the hollow mechanical body.

25 Optionally, the hollow mechanical body is tapered from the first end to the second end.

Optionally, the one of the optical components has a substantially wedge-shaped cross-section.

Optionally, the plurality of optical components includes a set of lenses.

Optionally, the set of lenses includes exactly four lenses.

30 Optionally, the set of lenses includes fewer than four lenses.

Optionally, the set of lenses includes more than four lenses.

Optionally, the emissive display device includes an organic light emitting diode display.

Optionally, the emissive display device includes micro light emitting diode display.

Optionally, the optical component at the first end of the stack configuration is adhesively attached to the first end of the hollow mechanical body.

Optionally, the engagement configuration of the optical component at the first end of the stack configuration maintains the other optical components within the hollow mechanical body  
5 without the use of adhesive applied to any of the other optical components.

Optionally, the other optical components are coaxially positioned within the hollow mechanical body.

Optionally, at least one of the optical components of the optical assembly is constructed from a plastic material.

10 Optionally, all of the optical components of the optical assembly are constructed from a plastic material.

Optionally, the hollow mechanical body is constructed from a plastic material.

Optionally, the emissive display device is configured to generate light corresponding to an image, and the optical assembly is configured to receive light from the emissive display  
15 device and output image light for coupling into a light-transmitting substrate.

Optionally, the optical system further comprises: a light-guide substrate having at least two major surfaces parallel to each other and a light-wave input aperture optically coupled to the first of the optical components via an optical coupling-in configuration.

Optionally, the first of the optical components has a prism-shaped cross-section and is  
20 configured to modify image light from the emissive display device prior to the image light reaching the optical coupling-in configuration so as to at least partially compensate for chromatic aberration.

Optionally, the hollow mechanical body further includes an inner sidewall configuration that is configured to reduce reflections of light transmitted by the optical components from  
25 interior portions of the hollow mechanical body.

There is also provided according to an embodiment of the teachings of the present invention an optical system. The optical system comprises: a hollow mechanical body including first and second ends; an optical assembly including a base optical element and a plurality of lens optical elements arranged in a stack configuration with the base optical element at a first end of  
30 the stack configuration and the lens optical elements deployed within the hollow mechanical body, each of the optical elements of the optical assembly including a set of engagement configurations, and for each pair of adjacent optical elements in the stack configuration at least some of the engagement configurations of a first optical element in the pair are configured to engage with at least some of the engagement configurations of a second optical element in the

pair, and some of the engagement configurations of the base optical element are configured to engage with corresponding engagement configurations at the first end of the hollow mechanical body so as to position the lens optical elements within the hollow mechanical body; and an emissive display device deployed at the second end of the hollow mechanical body configured to  
5 generate light corresponding to an image for propagating through the optical assembly.

Optionally, the optical system further comprises: a light-guide substrate having at least two major surfaces parallel to each other and an optical coupling region, and the base optical element is optically coupled to the optical coupling region and to an optical coupling-in configuration configured for coupling image light from the optical assembly into the light-guide  
10 substrate.

Optionally, the base optical element has a prism-shaped cross-section and is configured to modify image light from the emissive display device prior to the image light reaching the optical coupling-in configuration so as to at least partially compensate for chromatic aberration.

There is also provided according to an embodiment of the teachings of the present  
15 invention a method for constructing an optical system. The method comprises: obtaining a hollow mechanical body that includes a first end and a second end, the first end having a set of engagement configurations; molding a plurality of optical components using a corresponding plurality of molds that define a shape of the optical components, each shape including a set of engagement configurations; deploying the optical components in a stack configuration with at  
20 least a portion of the stack configuration within the hollow mechanical body, and for each pair of adjacent optical components in the stack configuration at least some of the engagement configurations of a first optical component in the pair engage with at least some of the engagement configurations of a second optical component in the pair, and some of the engagement configurations of the optical component at a first end of the stack configuration  
25 engage with the engagement configurations at the first end of the hollow mechanical body so as to maintain the portion of the stack within the hollow mechanical body; and deploying an emissive display device at the second end of the hollow mechanical body.

Optionally, the molding includes casting or injecting a plastic material into the molds.

Optionally, obtaining the hollow mechanical body includes: obtaining a mold defining a  
30 shape the hollow mechanical body, and casting or injecting a material into the mold defining the shape the hollow mechanical body.

Optionally, the method further comprises: applying adhesive between the optical component at the first end of the stack configuration and at least one portion of the first end.

Optionally, the hollow mechanical body is tapered from the first end to the second end.

Optionally, the second end of the hollow mechanical body includes a receiving portion for receiving the emissive display device, and an outwardly projecting sidewall configuration, the method further comprising: deploying a cover member at the outwardly projecting sidewall configuration of the second end of the hollow mechanical body.

5           Optionally, the optical component at the first end of the stack configuration and the cover member cooperate to seal the hollow mechanical body so as to substantially prevent environmental debris from contacting the optical components deployed within the hollow mechanical body.

10           Optionally, the method further comprises: adhesively attaching a mounting adapter to the emissive display device; and adhesively attaching the mounting adapter to a portion of the second end of the hollow mechanical body.

Optionally, the method further comprises: aligning the emissive display device with the optical components prior to adhesive attachment of the mounting adapter to the portion of the second end of the hollow mechanical body.

15           Optionally, the molds have parting lines that produce sidewall geometries of the respective optical components that reduce reflections of light, transmitted by the optical components, from interior portions of the hollow mechanical body.

20           Optionally, the hollow mechanical body further includes an inner sidewall configuration that is configured to reduce reflections of light, transmitted by the optical components, from interior portions of the hollow mechanical body.

25           There is also provided according to an embodiment of the teachings of the present invention an optical system. The optical system comprises: an image projector for producing light-waves corresponding to an image, the image projector including: an emissive display device configured to generate light corresponding to the image, and an optical assembly configured to receive light from the emissive display device and output image light; a light-transmitting substrate having a plurality of surfaces including two parallel major external surfaces and an edge non-parallel to the major external surfaces, the light-transmitting substrate configured to guide light by internal reflection between the major external surfaces; and a plate including a first and a second major external surface and a pair of edges, the first major external surface of the plate overlying the edge of the light-transmitting substrate, the second major external surface of the plate including an optical coupling-in configuration associated with the image projector and configured to couple image light from the image projector into the light-transmitting substrate, and at least one of the edges of the plate including an absorber to

30

substantially prevent light originating from the image projector from reflecting from the at least one of the edges of the plate.

Optionally, the second surface of the plate is a reflective surface that forms the optical coupling-in configuration.

5           Optionally, the reflective surface is formed by applying a reflective coating to the second surface of the plate.

Optionally, the reflective surface is formed by applying a dielectric coating to the second surface of the plate.

10           Optionally, the reflective surface is formed by applying a metallic coating to the second surface of the plate.

Optionally, the light that is substantially prevented from reflecting from the edges of the plate includes light that is reflected by the optical coupling-in configuration.

15           Optionally, the optical system further comprises: an optical coupling-out configuration associated with the light-transmitting substrate configured to couple out a proportion of the light guided between the major external surfaces of the light-transmitting substrate.

Optionally, the optical coupling-out configuration includes a plurality of partially reflective surfaces deployed within the light-transmitting substrate obliquely to the major external surfaces of the light-transmitting substrate.

20           Optionally, the optical coupling-out configuration includes a diffractive element associated with one of the major external surfaces of the light-transmitting substrate.

25           There is also provided according to an embodiment of the teachings of the present invention an optical system. The optical system comprises: an image projector for producing light-waves corresponding to an image, the image projector including: an emissive display device configured to generate light corresponding to the image, and an optical assembly configured to receive light from the emissive display device and output image light; a light-transmitting substrate having a plurality of surfaces including two parallel major external surfaces and an edge non-parallel to the major external surfaces, the light-transmitting substrate configured to guide light by internal reflection between the major external surfaces; and an optical coupling-in configuration associated with the image projector and configured to couple  
30           image light from the image projector into the light-transmitting substrate, the optical coupling-in configuration including: a reflective surface deployed at the edge of the light-transmitting substrate, and an angular selective reflective surface deployed within the light-transmitting substrate obliquely to the major external surfaces of the light-transmitting substrate, the angular selective reflective surface configured to: transmit light that is incident to the angular selective

reflective surface at a first range of incident angles such that the transmitted light is guided by internal reflection between the major external surfaces of the light-transmitting substrate, and reflect light that is incident to the angular selective reflective surface at a second range of incident angles.

5           Optionally, the angular selective reflective surface is parallel to the reflective surface.

          Optionally, the reflective surface is formed by applying a reflective coating to the edge of the light-transmitting substrate.

          Optionally, the angular selective reflective surface is formed by applying a dielectric coating to a surface within the light-transmitting substrate.

10          Optionally, the optical system further comprises: an optical coupling-out configuration associated with the light-transmitting substrate configured to couple out a proportion of the light guided between the major external surfaces of the light-transmitting substrate.

          Optionally, the optical coupling-out configuration includes a plurality of mutually parallel partially reflective surfaces deployed within the light-transmitting substrate obliquely to  
15 the major external surfaces of the light-transmitting substrate.

          Optionally, the angular selective reflective surface is non-parallel to the partially reflective surfaces.

          Optionally, the optical coupling-out configuration includes a diffractive element associated with one of the major external surfaces of the light-transmitting substrate.

20          There is also provided according to an embodiment of the teachings of the present invention an optical system. The optical system comprises: an image projector for producing light-waves corresponding to an image, the image projector including: an emissive display device configured to generate light corresponding to the image, and an optical assembly configured to receive light from the emissive display device and output image light, the optical  
25 assembly including a base optical element and a plurality of lens optical elements arranged in a stack configuration; a light-transmitting substrate having a plurality of surfaces including at least a pair of major external surfaces configured to guide light by internal reflection between the major external surfaces; and an optical coupling-in configuration associated with the base optical element and a coupling-in region of the light-transmitting substrate, and configured to couple  
30 image light from the image projector into the light-transmitting substrate, the base optical element has a prism-shaped cross-section and is configured to modify the image light prior to the image light reaching the optical coupling-in configuration so as to at least partially compensate for chromatic aberration.

Optionally, the plurality of surfaces of the light-transmitting substrate further includes an edge non-parallel to the major external surfaces, the optical system further comprising a plate including a first and a second major external surface and a pair of edges, the first major external surface of the plate overlying the edge of the light-transmitting substrate, the optical coupling-in configuration including a reflective surface deployed at the second major external surface of the plate, and at least one of the edges of the plate including an absorber to substantially prevent light, originating from the image projector, from reflecting from the at least one of the edges of the plate.

Optionally, the plurality of surfaces of the light-transmitting substrate further includes an edge non-parallel to the major external surfaces, and the optical coupling-in configuration includes: a reflective surface deployed at the edge of the light-transmitting substrate, and an angular selective reflective surface deployed within the light-transmitting substrate obliquely to the major external surfaces of the light-transmitting substrate, the angular selective reflective surface configured to: transmit light that is incident to the angular selective reflective surface at a first range of incident angles such that the transmitted light is guided by internal reflection between the major external surfaces of the light-transmitting substrate, and reflect light that is incident to the angular selective reflective surface at a second range of incident angles.

Optionally, the optical system further comprises: an optical coupling-out configuration associated with the light-transmitting substrate configured to couple out a proportion of the light guided between the major external surfaces of the light-transmitting substrate.

Optionally, the optical coupling-out configuration includes a plurality of partially reflective surfaces deployed within the light-transmitting substrate obliquely to the major external surfaces of the light-transmitting substrate.

Optionally, the optical coupling-out configuration includes a diffractive element associated with one of the major external surfaces of the light-transmitting substrate.

There is also provided according to an embodiment of the teachings of the present invention an optical system. The optical system comprises: an image projector for producing light-waves corresponding to an image, the image projector including: an emissive display device configured to generate light corresponding to the image, and an optical assembly configured to receive light from the emissive display device and output image light, the optical assembly including a plurality of optical components arranged in a stack configuration and having a mechanical interlocking engagement between each pair of adjacent optical components of the optical assembly; a light-transmitting substrate having a plurality of surfaces including two parallel major external surfaces and an edge non-parallel to the major external surfaces, the light-

transmitting substrate configured to guide light by internal reflection between the major external surfaces; and an optical coupling-in configuration associated with the image projector and configured to couple image light from the image projector into the light-transmitting substrate.

5 Optionally, the optical system further comprises: an optical coupling-out configuration associated with the light-transmitting substrate configured to couple out a proportion of the light guided between the major external surfaces of the light-transmitting substrate.

Optionally, the optical coupling-out configuration includes a plurality of partially reflective surfaces deployed within the light-transmitting substrate obliquely to the major external surfaces of the light-transmitting substrate.

10 Optionally, the optical coupling-out configuration includes a diffractive element associated with one of the major external surfaces of the light-transmitting substrate.

The term “light-transmitting substrate” as used herein in the description and claims refers to any light-transmitting body, preferably light-transmitting solid bodies, formed from transparent material, which are referred to interchangeably herein as “light-guide optical elements”, “light-guides” or “optical waveguide”.

15 Unless otherwise defined herein, all technical and/or scientific terms used herein have the same meaning as commonly understood by one of ordinary skill in the art to which the invention pertains. Although methods and materials similar or equivalent to those described herein may be used in the practice or testing of embodiments of the invention, exemplary methods and/or materials are described below. In case of conflict, the patent specification, including definitions, will control. In addition, the materials, methods, and examples are illustrative only and are not intended to be necessarily limiting.

#### BRIEF DESCRIPTION OF THE DRAWINGS

25 Some embodiments of the present invention are herein described, by way of example only, with reference to the accompanying drawings. With specific reference to the drawings in detail, it is stressed that the particulars shown are by way of example and for purposes of illustrative discussion of embodiments of the invention. In this regard, the description taken with the drawings makes apparent to those skilled in the art how embodiments of the invention may be practiced.

30 Attention is now directed to the drawings, where like reference numerals or characters indicate corresponding or like components. In the drawings:

FIG. 1 is a schematic side view, described above, of a prior art light-guide optical element employing partially-reflective surfaces, for use in a near-eye display;

FIG. 2 is a schematic side view of an optical system having an image projector that generates image light that is coupled into a light-guide optical element by an optical coupling-in configuration, according to an embodiment of the present invention;

5 FIGS. 3 and 4 are isometric views illustrating an image projector, constructed and operative according to an embodiment of the present invention;

FIG. 5 and 6 are isometric views corresponding to FIGS. 3 and 4, respectively, showing a hollow mechanical body of the image projector as transparent to illustrate an optical assembly of the image projector deployed within the hollow mechanical body;

10 FIGS. 7 and 8 are isometric exploded views corresponding to FIGS. 3 and 4, respectively, illustrating the components of the image projector;

FIG. 9 is a first side view of the optical assembly of the image projector of FIG. 3 showing the engagement between of the components of the optical assembly;

FIG. 10 is an exploded view corresponding to FIG. 9, showing the components of the optical assembly;

15 FIG. 11 is a second side view corresponding to FIG. 9;

FIG. 12 is an exploded view corresponding to FIG. 11, showing the components of the optical assembly;

FIG. 13 is a top view of the assembled optical assembly of the image projector;

20 FIG. 14 is a top view corresponding to FIG. 5, showing the assembled optical assembly deployed within the hollow mechanical body;

FIGS. 15 and 16 are central-vertical-plane and central-horizontal-plane cross-sectional views, respectively, taken through the image projector of FIG. 3;

25 FIG. 17 is a top view of the image projector of FIGS. 3 and 4, optically coupled to a light-guide optical element and an optical coupling-in configuration implemented as a plate, according to an embodiment of the present invention;

FIG. 18 is a bottom view corresponding to FIG. 17;

30 FIG. 19 is a cross-sectional view of a microdisplay device that emits image light and the optical power applying portions of the optical components of the optical assembly, and schematically showing the traversal of light from the microdisplay device through the optical components of the optical assembly;

FIGS. 20 and 21 are isometric views illustrating a first lens of the optical assembly according to a non-limiting implementation of the image projector, taken from a front side and a back side of the first lens, respectively;

FIGS. 22 and 23 are isometric views illustrating a second lens of the optical assembly according to a non-limiting implementation of the image projector, taken from a front side and a back side of the second lens, respectively;

5 FIGS. 24 and 25 are isometric views illustrating a third lens of the optical assembly according to a non-limiting implementation of the image projector, taken from a front side and a back side of the third lens, respectively;

FIGS. 26 and 27 are isometric views illustrating a fourth lens of the optical assembly according to a non-limiting implementation of the image projector, taken from a front side and a back side of the fourth lens, respectively;

10 FIGS. 28 and 29 are isometric views illustrating a base optical component of the optical assembly according to a non-limiting implementation of the image projector, taken from a front side and a back side of the base optical component, respectively;

FIGS. 30 and 31 are isometric views illustrating the hollow mechanical body for retaining the optical assembly according to a non-limiting implementation of the image projector, taken from in front of and behind the hollow mechanical body, respectively;

15 FIG. 32 is a plan view corresponding to FIG. 31, taken from a wide end of the hollow mechanical body;

FIG. 33 is a schematic side view of an optical system having an image projector that generates image light that is coupled into a light-guide optical element by an optical coupling-in configuration, implemented as a plate having a reflective surface, for reducing ghost images, according to an embodiment of the present invention;

FIG. 34 is an enlarged view of a portion of FIG. 33, showing some image light rays being reflected from the reflective surface of the plate so as to be coupled into the light-guide optical element, and some image light rays being absorbed by an edge of the plate;

25 FIG. 35 is a schematic side view of an optical system having an image projector that generates image light that is coupled into a light-guide optical element by an optical coupling-in configuration, implemented as a reflective surface and partially reflective surface, for reducing ghost images, according to an embodiment of the present invention; and

FIG. 36 is an enlarged view of a portion of FIG. 35, showing some image light rays being transmitted by the partially reflective surface so as to be coupled into the light-guide optical element, and some image light rays being reflected by the partially reflective surface so as to be coupled out of the light-guide optical element.

DESCRIPTION OF THE PREFERRED EMBODIMENTS

The present invention is an optical system having a light-guide optical element and a compact image projector, and a method for constructing the compact image projector.

5 The principles and operation of the optical systems and the method according to present invention may be better understood with reference to the drawings accompanying the description.

10 Before explaining at least one embodiment of the invention in detail, it is to be understood that the invention is not necessarily limited in its application to the details of construction and the arrangement of the components and/or methods set forth in the following description and/or illustrated in the drawings and/or the examples. The invention is capable of other embodiments or of being practiced or carried out in various ways. Initially, throughout this document, references are made to directions such as, for example, top and bottom, upper and lower, front and back, and the like. These directional references are exemplary only to illustrate the invention and embodiments thereof.

15 Referring now to the drawings, FIG. 2 illustrates an optical system, generally designated **40**, constructed and operative according to embodiments of the present invention. Generally speaking, the optical system **40** includes an LOE **50**, an optical coupling-in configuration **42** associated with a coupling-in region of the LOE **50**, and an image projecting optical arrangement (referred to hereinafter as an image projector) **100** associated with the optical coupling-in  
20 configuration **42** and the LOE **50**. Before describing the structure and operation of the optical system **40** and its various components and subcomponents in more detail, it is first noted that the present invention encompasses a number of different aspects believed to be of innovative significance each in its own right. One aspect of the present invention relates to the structure of the components of the image projector **100** and to the construction (manufacturing) of the image  
25 projector **100**. Another aspect of the present invention relates to the design of the optical components of the image projector **100** (and in certain embodiments, the design of a hollow mechanical body that maintains the optical components) to reduce the presence of ghost images and/or stray light rays. Another aspect of the present invention relates to the use of the image projector **100** with reflective-type optical coupling-in configurations that reduce the presence of  
30 ghost images and/or stray light rays. Another aspect of the present invention relates to particular components of the image projector that, when used in combination with reflective-type optical coupling-in configurations, compensate for effects of chromatic aberration introduced by the LOE **50** and/or the optical coupling-in configuration. In certain embodiments according to one or more aspects of the present invention, the image projector **100** may also be associated with a

portion of the LOE **50**. The various aspects of the present invention presented herein are of independent utility, and there is believed to be particular synergy when certain aspects of the present invention are used in combination with each other.

Turning now to the structural details of the LOE **50** illustrated in FIG. 2, it is noted that the  
5 LOE **50** is generally similar to the LOE **10** of FIG. 1. The LOE **50** is formed from transparent material (i.e., the LOE is a light-transmitting substrate) and has a pair of planar parallel faces (referred to interchangeably as “major external surfaces”) **52a**, **52b** for guiding light by internal reflection (preferably total internal reflection). The LOE **50** is deployed with one of the parallel faces **52b** in facing relation to the eye **68**, where the eye **68** is located in the EMB **71** at an ER **73**  
10 from the face **52b**. An image **54** (represented here schematically by a beam of illumination **54** including sample rays **54a** and **54b** which span the beam) propagates along the substrate by repeated internal reflection from the faces **52a**, **52b**, impinging on an optical coupling-out configuration associated with the LOE **50**, implemented as a sequence of parallel partially reflecting surfaces **62** deployed within the LOE **50** at an oblique angle to the parallel faces **52a**,  
15 **52b**, where part of the image intensity is reflected so as to be coupled out of the LOE **50** (substrate) as rays **64a** and **64b** toward the pupil **66** of the eye **68**. It is noted that the partially reflective surfaces **62** are merely illustrative of one non-limiting optical coupling-out configuration suitable for use with the LOE **50**, and other optical coupling configurations can be used to couple image light out of the LOE **50**. The optical coupling-out configuration may be any optical coupling  
20 arrangement which deflects part of the image propagating within the LOE **50** by internal reflection to an angle such that the deflected part of the image exits the LOE **50**. Other examples of such suitable optical coupling arrangements include, but are not limited to, one or more diffractive optical elements deployed on either of the faces **52a**, **52b**.

The image **54** is generated by the image projector **100**, and is injected (coupled) into the  
25 LOE **50** by the optical coupling-in configuration **42**. In contrast to the image projector **11** of FIG. 1 which typically employs a reflective-display device (e.g. LCoS) or a transmissive-display device (e.g., LCD) for generating image light, the image projector **100** of the present invention employs an emissive-display device that generates the image light that is to be coupled into the LOE **50**. In preferred embodiments, the coupling-in optical configuration **42** utilizes a reflective surface for  
30 coupling the image light waves into the LOE **50**. In FIG. 2, the reflective surface may be implemented as a reflective coating applied to the slant edge (surface) **56** of the LOE **50** that is oblique to the major surfaces **52a**, **52b**. As will be discussed in further detail, certain embodiments of according to an aspect of the present invention utilize a reflective-type coupling-in optical configuration with the image projector **100** in order to reduce ghost images, thereby

improving the quality of the image that is coupled out of the LOE **50**. Nevertheless, the image projector **100** of the present invention may be deployed together with a wedge-type of coupling-in optical configuration, such as the wedge **16** of FIG. 1.

Turning now collectively to FIGS. 3 – 32, there are shown various views of the image projector **100** (also in and of itself an optical system) and its corresponding components, according to embodiments of certain aspects of the present invention. Generally speaking, the image projector **100** includes a hollow mechanical body **102** (also referred to as a “barrel” due to its general barrel-like shape), an optical assembly **160** deployed within the barrel **102**, a microdisplay device **136**, and a cover member **146**. FIGS. 3 and 4 are different isometric views that illustrate the assembled image projector **100**, and FIGS. 5, 6 and 14 are various views that illustrate the assembled image projector **100** with the barrel **102** shown as transparent to more clearly illustrate the deployment of the optical assembly **160** within the barrel **102**.

With particular reference to FIGS. 7, 8 and 30 – 32, the barrel **102** has opposing open ends **104**, **106**, with the opening of one of the ends **104** being generally larger than the opening at the other of the ends **106**. These ends **104**, **106** may be referred to interchangeably as a wide end **104** and narrow end **106**. The barrel **102** includes several surfaces, including a pair of curved external surfaces **108a**, **108b** (referred to respectively as upper and lower external surfaces) and a pair of opposing planar (or nearly planar) external surfaces **110a**, **110b**. In certain non-limiting implementations, the surfaces **110a**, **110b** are parallel to each other. In other non-limiting implementations, the surfaces **110a**, **110b** are not parallel to each other and taper out gradually when moving from the narrow end **106** to the wide end **104**. A fifth surface **118** is formed at the narrow end **106**, and forms part of a receiving portion **120** that is configured to receive the microdisplay device **136**. In certain preferred but non-limiting implementations, the barrel **102** is constructed from a material that is not transparent to light waves emitted by the microdisplay device **136**.

The microdisplay device **136** is an emissive-display device that includes an emissive-display **138**, which may be implemented, for example, as an organic light emitting diode (OLED) display device, a microLED display device, or any other self-emitting microdisplay device that can generate image light without using an external light source, such as a back light or front light. Although not shown in the drawings, the microdisplay device **136** may include a polarizer as part of the emissive-display **138** in order to produce polarized image light waves. In certain embodiments, an electronic interfacing element **142** is electrically connected at one end thereof to, and extends laterally from, the emissive-display **138**. The electronic interfacing element **142** includes, or can be used to provide an electronic interface to, an electrical

connector, implemented, for example, as a cable or wire-bundle (e.g., ribbon cable), or any other type of connector that is capable of providing an electronic and/or data connection between electronic components, so as to provide electrical connection between the emissive-display **138** and one or more electronic elements, including, but not limited to power supplying devices, display driver electronics, one or more computerized storage (e.g., memory, such as a volatile or non-volatile memory), and/or one or more computerized processor implemented, for example, as a microprocessor, microcontroller, field-programmable gate array (FPGA), digital signal processor (DSP), application-specific integrated circuit (ASIC), field-programmable logic array (FPLA), and the like.

10 The external surfaces **108a**, **108b** are generally sloped or curved such that the barrel **102** is tapered from the wide end **104** to the narrow end **106** along the surfaces **108a**, **108b**. In addition, the surfaces **110a**, **110b** also generally taper from the wide end **104** to the narrow end **106** due to the difference in the size of the openings at the ends **104**, **106**. Portions of the interior (i.e., inner) sidewalls of the barrel **102** form an inner sidewall configuration **128** that includes several regions, including two upper regions **130a**, **132a** on the interior portions of the barrel **102** opposite the upper external surface **108a**, and two lower regions **130b**, **132b** on the interior portions of the barrel **102** opposite the lower external surface **108b**. The slope (curvature) of the regions **132a**, **132b** is larger than the slope (curvature) of the regions **130a**, **130b**, corresponding to the increased degree of tapering of the barrel **102** at the regions **132a**, **132b**. The barrel **102** further includes inner sidewalls **134a**, **134b** that are opposite the external surfaces **110a**, **110b**.

Turning now to FIGS. 7 – 12, the optical assembly **160** includes a plurality of optical components (also referred to as optical elements), including a set of lens optical elements (i.e., lenses) **200**, **300**, **400**, **500**, and a base optical element **600** (referred to interchangeably as the “base”). Although four lenses are illustrated here, other configurations of the image projector **100** are possible which utilize fewer than four lenses or more than four lenses. As will be discussed, the lenses **200**, **300**, **400**, **500** cooperate to perform various optical functions, including reduction of chromatic and/or spherical aberration, image size reduction, collimation, and the like.

As illustrated in FIGS. 5, 6, 9, 10, and 13 – 16, the optical components **200**, **300**, **400**, **500**, **600** of the optical assembly **160** are arranged in a stack configuration. The stack configuration is deployed such that the optical components **200**, **300**, **400**, **500** are positioned within the hollow portion (i.e., the inside) of the barrel **102**, as illustrated in FIGS. 5, 6 and 14 – 16, with the lens **200** positioned at one end of the stack configuration at or near the narrow end **106** of the barrel **102**, and with the base **600** positioned at the other end of the stack configuration

at or near the wide end **104** of the barrel **102**. A portion of the base **600** is also deployed within the hollow portion of the barrel **102**.

As will be discussed in greater detail below, each of the optical components **200**, **300**, **400**, **500**, **600** of the optical assembly **160** has a set of engagement configurations formed from an arrangement of one or more surfaces, grooves, beveled grooves, edges, beveled edges, segments of surfaces, or other similar such types of mechanical structures. In the present embodiments, some of the optical components have a set of two engagement configurations, while other of the optical components have a set of four engagements configurations. In particular, the optical component **200** at one end of the stack configuration has a pair of engagement configurations deployed on a back side of the optical component. The optical component **600** at the other end of the stack configuration has a first pair of engagement configurations deployed on a front side of the optical component and a second pair of engagement configurations projecting upward and downward from respective upper and lower surfaces of the optical component. The remaining optical components in the stack configuration (i.e., the optical components **300**, **400**, **500** positioned between the optical components **200**, **600** at the two ends of the stack configuration) each have a first pair of engagement configurations deployed on a front side of the optical component and a second pair of engagement configurations deployed on a back side of the optical component. For each pair of adjacent optical components in the stack configuration, at least some of the engagement configurations of each of the optical components in the pair are correspondingly configured so as to engage with each other. In other words, at least some of the engagement configurations of a first optical component in the pair are configured to engage with at least some of the engagement configurations of a second optical component in the pair, and the at least some of the engagement configurations of the second first optical component in the pair are configured to engage with the at least some of the engagement configurations of the first optical component in the pair. These engagement configurations of pairs of adjacent optical components are correspondingly configured, and engage with each other so as to promote an interlocking engagement between the adjacent optical components. The interlocking engagement between adjacent optical components is a mechanical engagement, meaning that no adhesive is used between the optical components to interconnect the optical components of the optical assembly **160**.

The base optical element **600** is formed from a material that is transparent to light waves emitted by the microdisplay device **136** (i.e., the base **600** is light-transmitting). The base **600** performs both optical and mechanical functions, in particular, some of the engagement

configurations of the base **600** are further configured to engage with the adjacent optical component (e.g., optical component **500**) in the stack configuration, while the remaining engagement configurations of the base **600** are configured to engage with corresponding engagement configurations of the barrel **102** located at the wide end **104**. The engagement  
5 between the base **600** and the barrel **102** enables the base **600** to maintain the lenses **200**, **300**, **400**, **500** within the barrel **102**. The optical functions performed by the base **600** will be described in detail in subsequent sections of the present disclosure.

The structure and the general optical functions of the optical components of the optical assembly **160** will now be described in more detail, with initial reference to FIGS. 7 – 12 and 20  
10 – 29. In general, each one of the lenses **200**, **300**, **400**, **500** is formed as a single unitary member that is comprised of two portions: a lensing portion (in the form of a pair of optical surfaces and the optical region between (i.e., bounded by) the optical surfaces) that applies optical power to incoming light, and one or more attachment portions (having engagement configurations) for interconnecting and attaching the lenses together and with the base **600**. The base **600** is also  
15 formed as a single unitary member that is comprised of two portions: an optical power applying portion (in the form of a pair of optical surfaces and the optical region between (i.e., bounded by) the optical surfaces) that changes the traversal angle of incoming light (slightly differently for each wavelength), and attachment portions (having engagement configurations) for engaging with the lens **500** and the barrel **102**, and for attaching the optical assembly **160** to the LOE **50**  
20 and/or optical coupling-in configuration **42**.

As will be discussed, for each optical component of the optical assembly **160**, the optical surfaces of that optical component are on opposing sides of the optical component, referred to as a front side and back side. Within the context of this document, the front side of an optical component of the optical assembly **160** generally refers to the side of the optical component that  
25 is closest to the narrow end **106** of the barrel **102** (and by equivalence, closest to the microdisplay device **136**, farthest from the wide end **104** of the barrel **102**, and farthest from the major surface **52b** of the LOE **50**). Also within the context of this document, the back side (also referred to as a “rear side”) of an optical component of the optical assembly **160** generally refers to the side of the optical component that is closest to the wide end **104** of the barrel **102** (and by  
30 equivalence, closest to the major surface **52b** of the LOE **50**, farthest from the narrow end **106** of the barrel **102**, and farthest from the microdisplay device **136**).

With continued reference to FIGS. 7 – 12 and 20 – 29, and with particular reference to FIGS. 20 and 21, the lens **200** includes two generally opposing optical surfaces **202**, **204** on the front side and the back side of the lens **200**, respectively. In this non-limiting example

implementation, the surface **202** is a concave surface and the surface **204** is a convex surface, and the surface profiles of both of the surfaces **202**, **204** are aspheric. Other surface profiles are contemplated herein, including, for example, spheric. The surface profiles of the lenses may depend on various factors, including, for example, the particular application of the image projector, the number of lenses in the optical assembly, and the material from which the lenses are manufactured. The surface **202** is concave with respect to a generally planar surface **210** on a front side of the lens **200**. The surface **210** includes upper and lower surface portions **212a**, **212b**. The surfaces **202**, **204**, together with portions of a pair of side surfaces **206**, **208**, generally define the lensing portion of the lens **200** that applies optical power to incoming light from the microdisplay device **136**. When deployed as part of the image projector **100**, the surface **202** is in facing relation with the microdisplay device **136**. The lens **200** is generally configured as a field lens, which performs various optical functions, including functions for reducing the size of the image generated by the microdisplay device **136** and/or counteracting the effects of field curvature aberration.

The lens **200** has a pair of legs **214a**, **214b** (or “branches”) which extend toward the back side of the lens **200** and outward from opposing peripheral portions of the lens **200**. In the non-limiting orientation of the optical assembly **160** shown in the drawings, the legs **214a**, **214b** extend from the respective upper and lower peripheral portions of the lens **200** (and therefore may be referred to within this context as “upper leg” **214a** and “lower leg” **214b**). The legs **214a**, **214b** generally flare outward from the center of the lens **200** along the vertical axis in the orientation of FIGS. 20 and 21, so as to generally correspond to the curvature or slope of the regions **132a**, **132b** of the inner sidewall configuration **128** of the barrel **102**, as can be seen in the cross-sectional view illustrated in FIG. 15. The legs **214a**, **214b** are generally flap-type structures, having major curved surfaces **216a**, **216b**, that extend tangentially outward from the top and bottom peripheral portions of the lens **200**. The side surfaces **206**, **208** generally flare outward from the center of the lens **200**, along the horizontal axis in the orientation of FIGS. 20 and 21, such that the surfaces **216a**, **216b** form isosceles trapezoid shapes in the top (and bottom) view of the lens **200**, as illustrated in FIGS. 13 and 14.

The legs **214a**, **214b** terminate at corresponding terminating regions **218a**, **218b** at upper and lower portions on the back side of the lens **200**. Parts of the terminating regions **218a**, **218b** form respective upper and lower engagement configurations **226a**, **226b** of the lens **200**. The terminating regions **218a**, **218b** include corresponding beveled edges **220a**, **220b**. The beveled edge **220a** is formed from a pair of (preferably coplanar) surfaces **222a**, **224a**, and the beveled edge **220b** is formed from a pair of surfaces **222b**, **224b**. It is noted that the surface **224a** also

forms an edge with the major upper curved surface **216a** of the leg **214a**, and the surface **224b** also forms an edge with the major lower curved surface **216b** of the leg **214b**. The beveled edges **220a**, **220b** (and the surfaces **222a**, **224a** and **222b**, **224b** from which they are formed) form the engagement configurations **226a**, **226b** of the lens **200**, and are configured to engage with  
5 corresponding engagement configurations of the lens **300**. The curved surfaces **216a**, **216b** have an arcuate profile (i.e., have an arc shape) in at least one dimension, in particular in the dimension spanning between the surfaces **206**, **208**. The beveled edges **220a**, **220b** also have an arcuate profile in the same dimension as the arcuate profile of the surfaces **216a**, **216b**. It follows that the surfaces **222a**, **224a** and **222b**, **224b** (that respectively form the beveled edges **220a** and  
10 **220b**) also have arcuate profiles in the same dimension as the arcuate profiles of the beveled edges **220a**, **220b**.

When inserted in the barrel **102**, the lens **200** is deployed such that the coplanar upper and lower surface portions **212a**, **212b** contact (or are in proximate contact with) an inner sidewall (surface) **126** of the barrel **102** that is generally opposite the external surface **118**.

15 The lens **200** further includes a pair of side edges, designated **131** and **133**. The edge **131** is formed from the intersection of the surfaces **206**, **210**, and the edge **133** is formed from the intersection of the surfaces **208**, **210**. The edges **131**, **133** are terminated at opposing ends by the surfaces **216a**, **216b** to form respective terminating corner regions. In certain embodiments, the edges **131**, **133** (and/or the terminating corner regions) can be used to restrict or limit rotation of  
20 the lens **200** (and the other lenses of the optical assembly **160**) within the barrel **102**.

With continued reference to FIGS. 7 – 12 and 20 – 29, and with particular reference to FIGS. 22 and 23, the lens **300** includes two generally opposing optical surfaces **302**, **304** on the front side and the back side of the lens **300**, respectively. The lens **300** is deployed with the surface **302** in facing relation to the surface **204** of the lens **200**. The surfaces **302**, **304**, together  
25 with a pair of side surfaces **306**, **308**, generally define the lensing portion of the lens **300** that applies optical power to incoming light. In this non-limiting example implementation, the lens **300** is a biconvex lens and the surface profiles of both of the surfaces **302**, **304** are aspheric. As can be seen, however, the degree of curvature of the surface **304** is significantly greater than that of the surface **302**. As will be discussed, the lens **300** operates together with the lens **400** to act  
30 like an achromatic doublet that reduces the effects of chromatic aberration.

The lens **300** has a pair of legs **310a**, **310b** (or “branches”) that extend outward from opposing peripheral portions of the lens **300**. In the non-limiting orientation of the optical assembly **160** shown in the drawings, the legs **310a**, **310b** extend from the respective upper and lower peripheral portions of the lens **300** (and therefore may be referred to within this context as

“upper leg” **310a** and “lower leg” **310b**). The legs **310a** and **310b** are generally flap-type structures, having major curved surfaces **312a**, **312b**, that extend tangentially outward from the top and bottom peripheral portions of the lens **300**. The side surfaces **306**, **308** generally flare outward from the center of the lens **300** along the horizontal axis in the orientation of FIGS. 22 and 23, such that the surfaces **312a**, **312b** form isosceles trapezoid shapes in the top (and bottom) view of the lens **300**, as illustrated in FIGS. 13 and 14.

The leg **310a** generally extends in two opposing directions (one toward the lens **200** and the other toward the lens **400**) and terminates at two terminating regions **314a**, **324a**. Similarly, the leg **310b** generally extends in two opposing directions (one toward the lens **200** and the other toward the lens **400**) and terminates at two terminating regions **314b**, **324b**. The terminating regions **314a**, **314b** are formed on the respective upper and lower portions of the front side of the lens **300**, and the terminating regions **324a**, **324b** are formed on the respective upper and lower portions of the back side of the lens **300**.

Parts of the terminating regions **314a**, **314b** form respective upper and lower first engagement configurations **336a**, **336b** of the lens **300** that are configured to engage with the corresponding engagement configurations **226a**, **226b** of the lens **200**. The terminating regions **314a**, **314b** include corresponding beveled grooves **316a**, **316b**. The beveled groove **316a** is formed from a pair of surfaces **318a**, **320a** formed on the front side of the lens **300**, and the beveled groove **316b** is formed from a pair of surfaces **318b**, **320b**. The surfaces **318a**, **318b** are preferably coplanar surfaces. The beveled grooves **316a**, **316b** have an arcuate profile (i.e., have an arc shape) in at least one dimension, in particular in the dimension spanning between the surfaces **306**, **308**. It follows that the surfaces **318a**, **320a** and **318b**, **320b** (that respectively form the beveled grooves **316a** and **316b**) also have arcuate profiles in the same dimension as the arcuate profiles of the beveled grooves **316a**, **316b**.

The beveled grooves **316a**, **316b** (and the surfaces **318a**, **320a**, **318b**, **320b** from which they are formed) form the upper and lower first engagement configurations **336a**, **336b** of the lens **300**, and are configured to engage with corresponding engagement configurations **226a**, **226b** of the lens **200**. In particular, the arcuate profile of the beveled groove **316a** matches the arcuate profile of the beveled edge **220a**, and the beveled edge **220a** is configured to fit in the beveled groove **316a**, such that portions of the surfaces **222a** and **224a** contact portions of the surfaces **318a** and **320a**, respectively. Likewise, the arcuate profile of the beveled groove **316b** matches the arcuate profile of the beveled edge **220b**, and the beveled edge **220b** is configured to fit in the beveled groove **316b**, such that portions of the surfaces **222b** and **224b** contact portions of the surfaces **318b** and **320b**, respectively. Within the context of this document, portions of two

surfaces are said to be in contact if those portions sit flush against each other. Such contact between two surfaces may also be considered as two surfaces abutting each other. The regions at which such surfaces contact each other are referred to herein as interface regions.

It is noted that in this non-limiting example configuration, each of the terminating regions **314a, 314b** includes two pairs of edges, designated **322a, 332a** and **322b, 332b**. The edge **322a** is formed from the intersection of the surfaces **328a, 306**, and the edge **332a** is formed from the intersection of the surfaces **328a, 308**. The surface **328a** is a generally planar surface having an arcuate profile that shares edges with both the surfaces **320a** and **312a**. Similarly, edge **322b** is formed from the intersection of the surfaces **328b, 306**, and the edge **332b** is formed from the intersection of the surfaces **328b, 308**. The surface **328b** is a generally planar surface (coplanar with the surface **328a**) having an arcuate profile that shares edges with both the surfaces **320b** and **312b**.

The edges **322a, 332a** are terminated at an upper end by the surface **312a** to form respective terminating corner regions. Similarly, the edges **322b, 332b** are terminated at a lower end by the surface **312b** to form respective terminating corner regions. In certain embodiments, the edges **322a, 332a, 322b, 332b** (and/or the terminating corner regions) can be used to restrict or limit rotation of the lens **300** (and the other lenses of the optical assembly **160**) within the barrel **102**.

Parts of the terminating regions **324a, 324b** form respective upper and lower second engagement configurations **338a, 338b** of the lens **300** that are configured to engage with corresponding engagement configurations of the lens **400**. The terminating regions **324a, 324b** include corresponding beveled edges **326a, 326b**. The beveled edge **326a** is formed from a pair of surfaces **330a, 334a**, and the beveled edge **326b** is formed from a pair of surfaces **330b, 334b**. The surfaces **330a, 330b** are preferably coplanar surfaces, and are formed on the back side of the lens **300**. The beveled edges **326a, 326b** (and the surfaces **330a, 334a, 330b, 334b** from which they are formed) form the upper and lower second engagement configurations **338a, 338b** of the lens **300**, and are configured to engage with corresponding engagement configurations of the lens **400**. The beveled edges **326a, 326b** have an arcuate profile (i.e., have an arc shape) in at least one dimension, in particular in the dimension spanning between the surfaces **306, 308**. It follows that the surfaces **330a, 334a** and **330b, 334b** (that respectively form the beveled edges **326a** and **326b**) also have arcuate profiles in the same dimension as the arcuate profiles of the beveled edges **326a, 326b**. It is noted that in this non-limiting example configuration, the surface **334a** also forms an edge (a beveled edge) with the major upper surface of the leg **310a**, and the surface **334b** also forms an edge (a beveled edge) with the major lower surface of the leg **310b**.

With continued reference to FIGS. 7 – 12 and 20 – 29, and with particular reference to FIGS. 24 and 25, the lens **400** includes two generally opposing optical surfaces **402**, **404** on the front side and the back side of the lens **400**, respectively. The lens **400** is deployed with the surface **402** in facing relation to the surface **304** of the lens **300**. The surfaces **402**, **404**, together with a pair of side surfaces **406**, **408**, generally define the lensing portion of the lens **400** that applies optical power to incoming light. In this non-limiting example implementation, the lens **400** is concave-convex (i.e., the surface **402** is concave, and the surface **404** is convex), and the surface profiles of the surfaces **402** and **404** are aspheric and spheric, respectively. As mentioned, in the present example the lens **400** operates together with the lens **300** to act like an achromatic doublet that reduces the effects of chromatic aberration. Preferably, the surfaces **304**, **402**, while not being identical inverted versions of each other, are generally correspondingly configured such that the surface **304** generally fits within the concavity created by the surface **402**.

The lens **400** has a pair of legs **410a**, **410b** (or “branches”) that extend outward from opposing peripheral portions of the lens **400**. In the non-limiting orientation of the optical assembly **160** shown in the drawings, the legs **410a**, **410b** extend from the respective upper and lower peripheral portions of the lens **400** (and therefore may be referred to within this context as “upper leg” **410a** and “lower leg” **410b**). The legs **410a**, **410b** are generally flap-type structures, having major curved surfaces **412a**, **412b**, that extend tangentially outward from the top and bottom peripheral portions of the lens **400**. The curved surfaces **412a**, **412b** have an arcuate profile (i.e., have an arc shape) in at least one dimension, in particular in the dimension spanning between the surfaces **406**, **408**. The side surfaces **406**, **408** generally flare outward from the center of the lens **400** along the horizontal axis in the orientation of FIGS. 24 and 25, such that the surfaces **412a**, **412b** form isosceles trapezoid shapes in the top (and bottom) view of the lens **400**, as illustrated in FIGS. 13 and 14.

The leg **410a** generally extends in two opposing directions (one toward the lens **300** and the other toward the lens **500**) and terminates at two terminating regions **414a**, **428a**. Similarly, the leg **410b** generally extends in two opposing directions (one toward the lens **300** and the other toward the lens **500**) and terminates at two terminating regions **414b**, **428b**. In the present non-limiting example configuration of the image projector **100**, the legs **410a**, **410b** extend further in the direction toward the lens **500** than in the direction toward the lens **300**. The terminating regions **414a**, **414b** are formed on the respective upper and lower portions of the front side of the lens **400**, and the terminating regions **428a**, **428b** are formed on the respective upper and lower portions of the back side of the lens **400**.

Parts of the terminating regions **414a**, **414b** form respective upper and lower first engagement configurations **436a**, **436b** of the lens **400** that are configured to engage with corresponding engagement configurations **338a**, **338b** of the lens **300**. The terminating regions **414a**, **414b** include corresponding beveled grooves **416a**, **416b**. The beveled groove **416a** is  
 5 formed from a pair of surfaces **418a**, **420a**, and the beveled groove **416b** is formed from a pair of surfaces **418b**, **420b**. The surfaces **418a**, **418b** are preferably coplanar surfaces, and are formed on the front side of the lens **400**. The beveled grooves **416a**, **416b** have an arcuate profile (i.e., have an arc shape) in at least one dimension, in particular in the dimension spanning between the surfaces **406**, **408**. It follows that the surfaces **418a**, **420a** and **418b**, **420b** (that respectively form  
 10 the beveled grooves **416a** and **416b**) also have arcuate profiles in the same dimension as the arcuate profiles of the beveled grooves **416a**, **416b**.

The beveled grooves **416a**, **416b** (and the surfaces **418a**, **420a**, **418b**, **420b** from which they are formed) form the first engagement configurations **436a**, **436b** of the lens **400**, and are configured to engage with corresponding engagement configurations **338a**, **338b** of the lens **300**.  
 15 In particular, the arcuate profile of the beveled groove **416a** matches the arcuate profile of the beveled edge **326a**, and the beveled edge **326a** is configured to fit in the beveled groove **416a**, such that portions of the surfaces **330a** and **334a** contact portions of the surfaces **418a** and **420a**, respectively. Likewise, the arcuate profile of the beveled groove **416b** matches the arcuate profile of the beveled edge **326b**, and the beveled edge **326b** is configured to fit in the beveled  
 20 groove **416b**, such that portions of the surfaces **330b** and **334b** contact portions of the surfaces **418b** and **420b**, respectively.

It is noted that in this non-limiting example configuration, each of the terminating regions **414a**, **414b** includes two pairs of edges, designated **422a**, **424a** and **422b**, **424b**. The edge **422a** is formed from the intersection of the surfaces **426a**, **406**, and the edge **424a** is formed from the intersection of the surfaces **426a**, **408**. The surface **426a** is another surface of the terminating region **414a** that forms an edge (beveled edge) with the surface **420a**. Similarly, the edge **422b** is formed from the intersection of the surfaces **426b**, **406**, the edge **424b** is formed from the intersection of the surfaces **426b**, **408**. The surface **426b** is another surface of the terminating region **414b** that forms an edge (beveled edge) with the surface **420b**. The surfaces **426a**, **426b**  
 25 are preferably coplanar surfaces, and are formed on the front side of the lens **400**.  
 30

The edges **422a**, **424a** are terminated at an upper end by the surface **412a** to form respective terminating corner regions. Similarly, the edges **422b**, **424b** are terminated at a lower end by the surface **412b** to form respective terminating corner regions. In certain embodiments, the edges **422a**, **424a**, **422b**, **424b** (and/or the terminating corner regions) can be used to restrict

or limit rotation of the lens **400** (and the other lenses of the optical assembly **160**) within the barrel **102**.

Parts of the terminating regions **428a**, **428b** form respective upper and lower second engagement configurations **438a**, **438b** of the lens **400** that are configured to engage with  
 5 corresponding engagement configurations of the lens **500**. The terminating regions **428a**, **428b** include corresponding beveled edges **430a**, **430b**. The beveled edges **430a**, **430b** are formed from respective pairs of surfaces **432a**, **434a** and **432b**, **434b**. The surfaces **432a**, **432b** are preferably coplanar surfaces, and are formed on the back side of the lens **400**. The beveled edges **430a**,  
 10 **430b** (and the surfaces **432a**, **434a**, **432b**, **434b** from which they are formed) form the upper and lower second engagement configurations **438a**, **438b** of the lens **400**, and are configured to engage with corresponding engagement configurations of the lens **500**. The beveled edges **430a**,  
 15 **430b** have an arcuate profile (i.e., have an arc shape) in at least one dimension, in particular in the dimension spanning between the surfaces **406**, **408**. It follows that the surfaces **432a**, **434a** and **432b**, **434b** (that respectively form the beveled edges **430a** and **430b**) also have arcuate profiles in the same dimension as the arcuate profiles of the beveled edges **430a**, **430b**.

With continued reference to FIGS. 7 – 12 and 20 – 29, and with particular reference to FIGS. 26 and 27, the lens **500** includes two generally opposing optical surfaces **502**, **504** on the front side and the back side of the lens **500**, respectively. The lens **500** is deployed with the surface **502** in facing relation to the surface **404** of the lens **400**. The surfaces **502**, **504**, together  
 20 with a pair of side surfaces **506**, **508**, generally define the lensing portion of the lens **500** that applies optical power to incoming light. In this non-limiting example implementation, the lens **500** is biconvex and the surface profiles of the surfaces **502** and **504** are aspheric and spheric, respectively. The lens **200** is generally configured as a collimating lens, and performs the primary collimating function of the optical assembly **160** by collimating the image light  
 25 produced by the microdisplay device **136**.

The lens **500** has a pair of legs **510a**, **510b** (or “branches”) which extend outward from opposing peripheral portions of the lens **500**. In the non-limiting orientation of the optical assembly **160** shown in the drawings, the legs **510a**, **510b** extend from the respective upper and lower peripheral portions of the lens **500** (and therefore may be referred to within this context as  
 30 “upper leg” **510a** and “lower leg” **510b**). The legs **510a**, **510b** are generally flap-type structures, having major curved surfaces **512a**, **512b**, that extend tangentially outward from the top and bottom peripheral portions of the lens **500**. The curved surfaces **512a**, **512b** have an arcuate profile (i.e., have an arc shape) in at least one dimension, in particular in the dimension spanning between the surfaces **506**, **508**. The side surfaces **506**, **508** generally flare outward from the

center of the lens **500** along the horizontal axis in the orientation of FIGS. 26 and 27, such that the surfaces **512a**, **512b** form isosceles trapezoid shapes in the top (and bottom) view of the lens **500**, as illustrated in FIGS. 13 and 14.

5 The leg **510a** generally extends in two opposing directions (one toward the lens **400** and the other toward the base **600**) and terminates at two terminating regions **514a**, **524a**. Similarly, the leg **510b** generally extends in two opposing directions (one toward the lens **400** and the other toward the base **600**) and terminates at two terminating regions **514b**, **524b**. In the present non-limiting example configuration of the image projector **100**, the legs **510a**, **510b** extend further in the direction toward the base **600** than in the direction toward the lens **400**. The terminating  
10 regions **514a**, **514b** are formed on the respective upper and lower portions of the front side of the lens **500**, and the terminating regions **524a**, **524b** are formed on the respective upper and lower portions of the back side of the lens **500**.

Parts of the terminating regions **514a**, **514b** form respective upper and lower first engagement configurations **536a**, **536b** of the lens **500** that are configured to engage with  
15 corresponding engagement configurations **438a**, **438b** of the lens **400**. The terminating regions **514a**, **514b** include corresponding beveled grooves **516a**, **516b**. The beveled groove **516a** is formed from a pair of surfaces **518a**, **520a**, and the beveled groove **516b** is formed from a pair of surfaces **518b**, **520b**. The surfaces **518a**, **518b** are preferably coplanar surfaces, and are formed on the front side of the lens **500**. The beveled grooves **516a**, **516b** have an arcuate profile (i.e.,  
20 have an arc shape) in at least one dimension, in particular in the dimension spanning between the surfaces **506**, **508**. It follows that the surfaces **518a**, **520a** and **518b**, **520b** (that respectively form the beveled grooves **516a** and **516b**) also have arcuate profiles in the same dimension as the arcuate profiles of the beveled grooves **516a**, **516b**.

The beveled grooves **516a**, **516b** (and the surfaces **518a**, **520a**, **518b**, **520b** from which  
25 they are formed) form the first engagement configurations **536a**, **536b** of the lens **500**, and are configured to engage with corresponding engagement configurations **438a**, **438b** of the lens **400**. In particular, the arcuate profile of the beveled groove **516a** matches the arcuate profile of the beveled edge **430a**, and the beveled edge **430a** is configured to fit in the beveled groove **516a**, such that portions of the surfaces **432a** and **434a** contact portions of the surfaces **518a** and **520a**,  
30 respectively. Likewise, the arcuate profile of the beveled groove **516b** matches the arcuate profile of the beveled edge **430b**, and the beveled edge **430b** is configured to fit in the beveled groove **516b**, such that portions of the surfaces **432b** and **432b** contact portions of the surfaces **518b** and **520b**, respectively.

It is noted that in this non-limiting example configuration, each of the terminating regions **514a**, **514b** includes two pairs of edges, designated **522a**, **526a** and **522b**, **526b**. The edge **522a** is formed from the intersection of the surfaces **532a**, **506**, and the edge **526a** is formed from the intersection of the surfaces **532a**, **508**. The surface **532a** is a generally planar surface formed on the front side of the lens **500** and having an arcuate profile that shares edges with both the surfaces **520a** and **512a**. Similarly, the edge **522b** is formed from the intersection of the surfaces **532b**, **506**, and the edge **526b** is formed from the intersection of the surfaces **532b**, **508**. The surface **532b** is a generally planar surface (coplanar with the surface **532a**) formed on the front side of the lens **500** and having an arcuate profile that shares edges with both the surfaces **520b** and **512b**.

The edges **522a**, **526a** are terminated at an upper end by the surface **512a** to form respective terminating corner regions. Similarly, the edges **522b**, **526b** are terminated at a lower end by the surface **512b** to form terminating corner regions. In certain embodiments, the edges **522a**, **526a**, **522b**, **526b** (and/or the terminating corner regions) can be used to restrict or limit rotation of the lens **500** (and the other lenses of the optical assembly **160**) within the barrel **102**.

Parts of the terminating regions **524a**, **524b** form respective upper and lower second engagement configurations **538a**, **538b** of the lens **500** that are configured to engage with corresponding engagement configurations of the base **600**. The terminating regions **524a**, **524b** include corresponding beveled edges **528a**, **528b**. The beveled edges **528a**, **528b** are formed from respective pairs of surfaces **530a**, **534a** and **530b**, **534b**. The surfaces **534a**, **534b** are preferably coplanar, and are formed on the back side of the lens **500**. The beveled edges **528a**, **528b** (and the surfaces **530a**, **534a**, **530b**, **534b** from which they are formed) form second engagement configurations of the lens **500**, and are configured to engage with corresponding engagement configurations of the base **600**. The beveled edges **528a**, **528b** have an arcuate profile (i.e., have an arc shape) in at least one dimension, in particular in the dimension spanning between the surfaces **506**, **508**. It follows that the surfaces **530a**, **534a** and **530b**, **534b** (that respectively form the beveled edges **528a** and **528b**) also have arcuate profiles in the same dimension as the arcuate profiles of the beveled edges **528a**, **528b**.

As can be seen in FIGS. 5, 6, 9, 10 and 13 – 15, the optical components **200**, **300**, **400**, **500**, **600** are arranged front to back in the stack configuration, meaning that the front side or back side of a given optical component is in facing relation with the back side or front side of the adjacent optical component in the stack. In addition, the lenses **200**, **300**, **400**, **500** are arranged in a nested configuration. FIGS. 13 and 14 show a particular feature of the nested configuration, in which the surfaces **206**, **306**, **406**, **506** and the surfaces **208**, **308**, **408**, **508** lay in two sets of

parallel planes (i.e., the surfaces **206, 306, 406, 506** are parallel to each other, and the surfaces **208, 308, 408, 508** are parallel to each other and oblique to the planes of the surfaces **206, 306, 406, 506**). FIGS. 5, 6, 9, 10 and 15 show another particular feature of the nested configuration, in which the legs of the lenses **200, 300, 400, 500** generally increasingly expand outward when moving from the narrow end **106** to the wide end **104** of the barrel **102** (i.e., the legs **510a, 510b** of the lens **500** expand wider than the legs **410a, 410b** of the lens **400**, which expand wider than the legs **310a, 310b** of the lens **300**, which expand wider than the legs **214a, 214b** of the lens **200**). As a byproduct, portions of the relevant terminating regions of the lens **200** fit inside portions of the relevant terminating regions of the lens **300**, portions of the relevant terminating regions of the lens **300** fit inside portions of the relevant terminating regions of the lens **400**, and portions of the relevant terminating regions of the lens **400** fit inside portions of the relevant terminating regions of the lens **500**. This gradual increase in the degree of outward expansion of the legs of the lenses, and the fitting between the portions of the terminating regions, promotes an overall contour at the major surfaces **216a, 216b, 312a, 312b, 412a, 412b, 512a, 512b** of the lenses of optical assembly **160**, that generally corresponds to the contour of the interior portion of the barrel **102** (i.e., the regions **130a, 130b, 132a, 132b**).

In certain preferred embodiments, each of the lenses **200, 300, 400, 500** is symmetric about the central optical axis of the optical assembly **160**. In FIG. 13, the optical axis is the vertical axis that is centered on the lenses **200, 300, 400, 500** (i.e., the axis that is normal to the surfaces **212a, 212b, 328a, 328b, 426a, 426b, 532a, 532b** and that passes through the center of each of the lenses **200, 300, 400, 500**). Looking at the cross-section of the image projector **100** taken in the plane parallel to the optical axis (illustrated in FIG. 16), the lenses **200, 300, 400, 500** are planar truncated lenses with two-fold symmetry about the optical axis. Looking at the cross-section of the image projector **100** taken in the plane normal to the optical axis (illustrated in FIG. 15), it can be seen that the lenses **200, 300, 400, 500** do not have such symmetry about the axis orthogonal to the optical axis. In fact, and as described above, the pairs of optical surfaces for each of the lenses **200, 300, 400, 500** are non-identical (and in most cases have different surface profiles), which precludes having such symmetry. The variation in the geometries of the optical surfaces of the lenses lends to an aspect ratio for each lens that is significantly different from unity. Within the context of this document, the aspect ratio of a lens is generally defined as the ratio of the lens width to the lens length, where the length is measured as roughly the distance between the legs of the lens, and where the width is measured as roughly the distance between the pair of side surfaces of the lens. A particularly suitable range of aspect

ratios that have been found to provide good image uniformity at the image projector **100** output is 0.3 – 0.5, 0.1 – 0.3, 0.3 – 0.5, 0.1 – 0.35 for the lenses **200**, **300**, **400**, **500**, respectively.

With continued reference to FIGS. 7 – 12 and 20 – 29, and with particular reference to FIGS. 28 and 29, the base **600** includes two planar optical surfaces **602**, **604** on the front side and  
5 the back side of the base **600**, respectively. The base **600** is deployed with the surface **602** in facing relation to the surface **504** of the lens **500**, and with the surface **604** in facing relation with one of the major surfaces **52b** of the LOE **50**. The surface **602** is preferably at an oblique angle relative to the surface **210** (of the lens **200**) and the surface **126** (of the barrel **102**).

The base **600** performs optical functions for compensating or counteracting chromatic  
10 aberration introduced by the LOE **50** and the optical coupling-in configuration **42** (when, for example, implemented as a reflective-type optical coupling-in configuration), in accordance with another aspect of the present invention, as well as mechanical functions for maintaining the lenses of the optical **160** within the barrel **102**.

The optical functions according to this aspect of the present invention will be discussed  
15 here briefly, and will be discussed in more detail in subsequent sections of the present disclosure. By way of introduction, chromatic aberration is an effect of an optical element, such as a prism, to fail to direct all colors of light to the same point. The refractive index of the optical element varies with respect to the wavelength of light, such that when white light impinges on the optical element, the individual color component wavelengths of the white light are dispersed, spatially  
20 separating the component colors.

When deploying an LOE and the optical coupling-in configuration (for example as part of a NED or HMD device) the LOE and the optical coupling-in configuration may be positioned at an oblique angle relative to the eye of the viewer. This can partly be seen in FIG. 1, in which the surfaces **17c** and **15** (of the coupling prism **16** and LOE **10**) are obliquely angled relative to  
25 the EMB **28**. Although not explicitly clear from FIG. 1, the major external surface **12b** may also be positioned oblique to the EMB **28** (a phenomena colloquially referred to as “face curve”). In such scenarios, the LOE and the optical coupling-in configuration exhibit prismatic properties, which may cause chromatic aberration, whereby the image (that is coupled out of the LOE by the optical coupling-out configuration, e.g., the partially reflecting surfaces) is distorted due to the  
30 non-symmetric coupling-in and coupling-out angles of the FOV. In addition, the light waves emanating from the image projector that are coupled into the LOE and that are coupled out toward the eye are chromatically aberrated. In order to counteract chromatic aberration, the base **600** is designed as a prism (or wedge) in a cross-sectional plane. This is illustrated in FIGS. 16 and 19, where it can be seen that the surface **604** is oblique to the surface **602**. In this

configuration, the surface **604** is deployed parallel to the major surface **52b** of the LOE **50**, and the oblique angle of the surface **604** (relative to the surface **602**) defines (in part) the overall angle at which the image projector **100** is deployed relative to the LOE **50**. This image projector deployment angle (labeled as  $\theta_{\text{proj}}$  in FIG. 17) is measured as the angle between the central optical axis of the lenses of the optical assembly **160** (which is the vertical axis in FIG. 17, and is generally along the normal to the plane of the microdisplay device **136**) and the plane of the major external surface **52b**. Details of the optical functions of the base **600** for counteracting chromatic aberration will be described in further detail below. It is generally noted that the aforementioned oblique angles associated with the surfaces **602**, **604** are designed relative to the LOE **50**.

Continuing now with the description of the structure of the base **600**, a pair of planar side surfaces (sidewalls) **606**, **608** bound and extend between the surfaces **602**, **604**. The side surface **606** is generally wider (or broader) than the side surface **608** due to the inclination of the surface **604** relative to the surface **602**. For this reason, the surfaces **606** and **608** may be referred to interchangeably as a broad surface and a narrow surface, respectively.

The base **600** generally includes upper and lower peripheral portions **610a**, **610b** that sit at opposing ends of the base **600**. Curved surfaces **612a**, **612b** form the outer surfaces of the peripheral portions **610a**, **610b**. These curved surfaces **612a**, **612b** are referred to as “upper curved surface” **612a** and “lower curved surface” **612b**. The curvature of the curved surfaces **612a**, **612b** generally corresponds to the curvature of the regions **130a**, **130b** of the barrel **102**. Planar surfaces **614a**, **614b** (preferably coplanar surfaces) are formed on the front side of the peripheral portions **610a**, **610b**.

A pair of protrusions **616a**, **616b** extend outward from the surfaces **614a**, **614b** (in the direction toward the lens **500** when the optical assembly **160** is assembled). The protrusions **616a**, **616b** are interchangeably referred to as “upper protrusion” **616a** and “lower protrusion” **616b**. Portions of the protrusions **616a**, **616b**, together with the surfaces **614a**, **614b**, form respective upper and lower **638a**, **638b** first engagement configurations of the base **600** that are configured to engage with corresponding engagement configurations **538a**, **538b** of the lens **500**.

The protrusions **616a** and **616b** are formed by the pairs of surfaces **618a**, **622a** and **618b**, **622b**, respectively. A pair of beveled grooves **620a** and **620b** are formed from the pair of surfaces **614a**, **618a** and **614b**, **618b**, respectively. The beveled grooves **620a**, **620b** have an arcuate profile (i.e., have an arc shape) in at least one dimension, in particular in the dimension spanning between the surfaces **606**, **608**. It follows that the surfaces **614a**, **618a** and **614b**, **618b**

(that respectively form the beveled grooves **620a** and **620b**) also have arcuate profiles in the same dimension as the arcuate profiles of the beveled grooves **620a**, **620b**.

The beveled grooves **620a**, **620b** (and the surfaces **614a**, **618a**, **614b**, **618b** from which they are formed) form the upper and lower first engagement configurations **638a**, **638b** of the base **600**, and are configured to engage with corresponding engagement configurations **538a**, **538b** of the lens **500**. In particular, the arcuate profile of the beveled groove **620a** matches the arcuate profile of the beveled edge **528a**, and the beveled edge **528a** is configured to fit in the beveled groove **620a**, such that portions of the surfaces **530a** and **534a** contact portions of the surfaces **618a** and **614a**, respectively. Likewise, the arcuate profile of the beveled groove **620b** matches the arcuate profile of the beveled edge **528b**, and the beveled edge **528b** is configured to fit in the beveled groove **620b**, such that portions of the surfaces **530b** and **534b** contact portions of the surfaces **618b** and **614b**, respectively.

A flange **624a** projects upwardly from a center region of the curved surface **612a**. The flange **616a** is configured to slideably engage with a channel **114a** in the upper part of a receiving portion **112** of the wide end **104** of the barrel **102**. In the drawings, the channel **114a** is illustrated as a slit or slot in the upper portion of the end **104** that extends inwardly by a particular amount, and that is terminated by a sidewall **116a** in the external surface **108a**. The flange **624a** and the channel **114a** are correspondingly configured so as to promote an interlocking engagement between the flange **624a** and the channel **114a**.

Similarly, a flange **624b** projects downwardly from a center region of the curved surface **612b**. The flange **624b** is configured to slideably engage with a channel **114b** in the lower part of the receiving portion **112** of the wide end **104** of the barrel **102**. In the drawings, the channel **114b** is illustrated as a slit or slot in the lower portion of the end **104** that extends inwardly by a particular amount, and that is terminated by a sidewall **116b** in the external surface **108b**. The flange **624b** and the channel **114b** are correspondingly configured so as to promote an interlocking engagement between the flange **624b** and the channel **114b**. The flanges **624a**, **624b** form part of respective upper and lower second engagement configurations **640a**, **640b** of the base **600**, and the channels **114a**, **114b** form part of a set of engagement configurations **117a**, **117b** of the barrel **102**.

The flanges **624a**, **624b** include respective front (preferably coplanar) surfaces **626a**, **626b** formed on the front side of the base **600**, that form respective contiguous surfaces with the planar surfaces **614a**, **614b**. The base **600** is configured to engage with the barrel **102** at the receiving portion **112** such that the flanges **624a**, **624b** slideably engage the corresponding channels **114a**, **114b**, which form part of engagement configurations **117a**, **117b** of the barrel

102. When the base **600** is engaged with the receiving portion **112**, the surfaces the flanges **624a**, **624b** are inserted into the channels **114a**, **114b** such that portions of the surfaces **626a**, **626b** contact the respective sidewalls **116a**, **116b** (which restrict further movement of the base **600** into the interior portion of the barrel **102**). In addition, portions of the curved surfaces **612a**, **612b** are brought into proximity (i.e., into near contact, or in some cases into contact) with portions of the respective regions **130a**, **130b** of the inner sidewall configuration **128**.

It is noted that the flanges **624a**, **624b** and the channels **114a**, **114b** are correspondingly dimensioned so as to promote the corresponding configuration between the flanges **624a**, **624b** and the channels **114a**, **114b**, which that enables the interlocking slideable engagement between the flanges **624a**, **624b** and the channels **114a**, **114b**. The corresponding configuration between the flanges **624a**, **624b** and the channels **114a**, **114b**, while not necessarily a fixed interlocking engagement, is such that when the flanges **624a**, **624b** are received by the channels **114a**, **114b**, the base **600** is maintained in the receiving portion **112**. A fixed engagement is preferably achieved by applying adhesive between portions of the base **600** and portions of the receiving portion **112**, as will be discussed below. In certain non-limiting implementations, the flanges **624a**, **624b** and the channels **114a**, **114b** are correspondingly dimensioned such that a snap-type engagement is created, promoting a more secure interlocking engagement between the base **600** and the receiving portion **112**.

The base **600** additionally includes a coupling configuration **628** formed on a back side of the base **600**, in the form of a sidewall configuration that projects outward from the periphery of the surface **604** so as to bound the surface **604** on all sides. The coupling configuration **628** is configured for operatively coupling the image projector **100** to the LOE **50** and/or the optical coupling-in configuration **42**, so as to form a unitary optical system **40**. In certain non-limiting implementations in which the LOE **50** is associated with a reflective-type of optical coupling-in configuration **42**, portions of the coupling configuration **628** are optically coupled to LOE **50** at the major external surface **52b**, at part of an “optical coupling-in region” of the LOE **50**. In some of such implementations, portions of the coupling configuration **628** are also optically coupled to the optical coupling-in configuration, as illustrated for example in FIGS. 17 and 18.

In the particular non-limiting implementation illustrated in the drawings, the coupling configuration **628** includes an upper portion **630a** that has a surface that joins the curved surface **612a**, and a lower portion **630b** that has a surface that joins the curved surface **612b**. The upper and lower portions **630a**, **630b** are optically coupled to the optical coupling region of the LOE **50**. The coupling configuration **628** further includes a side portion **632** that extends between the portions **630a**, **630b** (whereby the portions **630a**, **630b**, **632** form a contiguous surface). The side

portion **632** joins the side surface **606**. In the present non-limiting implementation, the coupling configuration **628** also includes an elongated portion **634** generally opposite from the side portion **632**, that extends along between the upper and lower portions **630a**, **630b** along the periphery of the base **600**. The side portion **632** includes a pair of coupling configurations **636a**, **636b** positioned at or near the upper and lower ends of the elongated portion **634**. These coupling configurations **636a**, **636b** are configured to optically couple the base **600** to the optical coupling-in configuration in certain particularly preferred implementations, for example, implementations in which the optical coupling-in configuration is implemented as a transparent plate of a prescribed thickness (as will be described with reference to FIGS. 33 and 34) deployed on the edge **56** of the LOE **50**. In such a non-limiting implementation, the coupling configurations **636a**, **636b** are configured to optically couple the base **600** to an edge of the transparent plate. The aforementioned optical couplings are enabled, in certain preferred but non-limiting implementations, by mechanical attachment of the coupling configuration **628** to the LOE **50** and the coupling-in configuration.

It is noted that in implementation in which a wedge-base optical coupling-in configuration is used, the coupling configuration **628** includes surfaces that are configured to mechanically couple the base **600** to an external surface of the wedge so as to provide an optical coupling between the base **600** and the wedge.

The optical couplings between the coupling configuration **628** and the LOE and/or the optical coupling-in configuration may be implemented in various ways. One non-limiting example of an optical coupling is a direct coupling using adhesive techniques (i.e., optical cement). Another non-limiting example is a mechanical coupling, in which the image projector **100** is mechanically positioned so as to place the portions **630a**, **630b**, **632**, **634** at the requisite positions relative to the LOE and/or the optical coupling-in configuration via a mechanical module or mechanical assembly.

The following paragraphs describe the process for assembling the image projector **100** according to embodiments of the present disclosure, which is a sub-process in the process of constructing (i.e., manufacturing) the image projector **100**. The assembly process includes a sequence of steps, many of which can be performed in an order different than the particular order described herein.

The optical components of the optical assembly **160** are arranged in a stack configuration, whereby engagement configurations of each optical component engage with engagement configurations of adjacent optical component in the stack, all as described above. In general, the engagement configurations **226a**, **226b** of the lens **200** and the first engagement

configurations **336a**, **336b** of the lens **300** engage with each other. The second engagement configurations **338a**, **338b** of the lens **300** and the first engagement configurations **436a**, **436b** of the lens **400** engage with each other. The second engagement configurations **438a**, **438b** of the lens **400** and the first engagement configurations **536a**, **536b** of the lens **500** engage with each other. The second engagement configurations **538a**, **538b** of the lens **500** and the first engagement configurations **638a**, **638b** of the base **600** engage with each other.

In certain non-limiting construction methods, the stack configuration may first be formed outside of the barrel **102**. The stack may then be inserted into the hollow opening of the barrel **102**, via the receiving portion **112** at the wide end **104** of the barrel **102**. The portions **212a**, **212b** of the surface **210** come into contact with the sidewall (surface) **126** of the barrel **102**, which restricts further movement of the stack into the interior portion of the barrel **102**. Simultaneously, the second engagement configurations **640a**, **640b** of the base **600** engage with the engagement configurations **117a**, **117b** at the receiving portion **112** (i.e., the flanges **616a**, **616b** slideably engage with the channels **114a**, **114b**), so as to maintain the portion of the stack within the barrel **102**.

In a preferable non-limiting construction method, the optical components are stacked one by one in the interior portion of the barrel **102**. For example, the lens **200** may first be inserted into the barrel **102** (such that the surface portions **212a**, **212b** come into contact with the sidewall (surface) **126**). The lens **300** may be then be inserted into the barrel **102** such that the engagement configurations **226a**, **226b** of the lens **200** and the first engagement configurations **336a**, **336b** of the lens **300** engage with each other. The lens **400** may be then be inserted into the barrel **102** such that the second engagement configurations **338a**, **338b** of the lens **300** and the first engagement configurations **436a**, **436b** of the lens **400** engage with each other. The lens **500** may be then be inserted into the barrel **102** such that the second engagement configurations **438a**, **438b** of the lens **400** and the first engagement configurations **536a**, **536b** of the lens **500** engage with each other. The base **600** may be then be engaged with the receiving portion **112** of the barrel **102** such that the second engagement configurations **538a**, **538b** of the lens **500** and the first engagement configurations **638a**, **638b** of the base **600** engage with each other, and such that the second engagement configurations **640a**, **640b** of the base **600** and the engagement configurations **117a**, **117b** at the receiving portion **112** engage with each other, so as to maintain the portion of the stack within the barrel **102**. When the base **600** is engaged with the barrel **102** (i.e., when the engagement configurations **640a**, **640b**, **117a**, **117b** engage with each other), portions of the surfaces **606**, **608** (near the front side of the base **600**) are positioned within the

barrel **102** (as can be seen in FIGS. 3 and 4). The surface **602** is also fully maintained within the housing defined by the barrel **102** and the exterior portions of the base **600**.

The mechanical interlocking engagement between the adjacent optical components (via the cooperation between the correspondingly configured engagement configurations of the adjacent optical components), and the interlocking engagement of the base **600** with the receiving portion **112**, enables deployment of the lenses of the optical assembly **160** such that the lenses are accurately coaxially positioned (i.e., centered and coaxially aligned with respect to each other), and further enables deployment such that the lenses are maintained within the barrel **102** without the use of any adhesives (e.g., optical cement) between the lenses. In addition, the engagement of the flanges **624a**, **624b** and the channels **114a**, **114b** generally limits the rotation of the base **600** about the optical axis of the optical assembly **160**. Since the optical components of the optical assembly **160** are interlocked (by the aforementioned engagements configurations), the coaxial rotation of the optical components of the entire optical assembly **160** is limited by the engagement of the base **600** with receiving portion **112**. The coaxial rotation of the optical components of the entire optical assembly **160** can be further limited by cooperation between one or more portions of the lenses and the regions **132a**, **132b** of the inner sidewall configuration **128** (which form rotation limiting configurations of the inner sidewall configuration **128**).

In certain preferred but non-limiting implementations, one or more of the edges **131**, **133**, **322a**, **332a**, **322b**, **332b**, **422a**, **424a**, **422b**, **424b**, **522a**, **526a**, **522b**, **526b** (alone or in combination with one or more of their respective terminating corner regions) form rotation limiting configurations of the lenses **200**, **300**, **400**, **500**. These rotation limiting configurations cooperate with rotation limiting configurations formed from corresponding portions of the regions **132a**, **132b** of the inner sidewall configuration **128** to restrict movement of the one or more of the edges **131**, **133**, **322a**, **332a**, **322b**, **332b**, **422a**, **424a**, **422b**, **424b**, **522a**, **526a**, **522b**, **526b** (and/or corner regions), and thereby restrict the rotation of the corresponding lens **200**, **300**, **400**, **500** and the entire optical assembly **160**. As a result, the amount of rotation of the lenses of the optical assembly **160** about three major axes (the optical axis, as well as the two axes normal to the optical axis) is limited to a small degree of acceptable rotation (i.e., within an acceptable tolerance) by the rotation limiting configurations.

In certain embodiments, in order to more securely retain (and in some cases, fixedly retain) the relevant portion of the stack (i.e., the lenses **200**, **300**, **400**, **500**) within the barrel **102**, the base **600** is attached to the end **104** using an adhesive (e.g., optical cement). For example, a layer of adhesive may be applied to the portions of the flanges **624a**, **624b** that engage with the channels **114a**, **114b**. Additional layers of adhesive may be applied at various portions of the

surfaces **606**, **608** which may contact portions of the regions **130a**, **130b**. The amount of adhesive is preferably minimal, so as to prevent leakage of excess adhesive into the interior portion of the barrel **102**, thereby preventing the adhesive from entering the optical path of the optical assembly **160** and adversely affecting the trajectories of light rays propagating through the optical assembly **160**.

After the optical assembly **160** is securely retained inside the barrel **102** (via cementing the base **600** to the wide end **104** of the barrel **102**), the microdisplay device **136** may be deployed in the receiving portion **120** at the narrow end **106** of the barrel **102**. Preferably, part of the procedure for deployment of the microdisplay device **136** includes aligning (actively aligning) the microdisplay device **136** with the optical assembly **160**. The alignment may be performed using any well-known alignment techniques and procedures, which typically utilize optical test bench equipment, such as autocollimator devices, image capture devices, and the like. These alignment techniques and procedures are used in order to ensure that the quality of the image, generated by the microdisplay device **136**, that propagates through the optical assembly **160** (and through the LOE **50**) is of sufficient quality in accordance with one or more image quality metrics and optical system design specifications. The alignment may include, for example, rotation (about one or more rotational axis), lateral positioning, front-back positioning or any other adjustment of the microdisplay device **136** within the receiving portion **120** while analyzing output images (at the image projector **100** output and/or the LOE **50** output) captured by an image capture device (e.g., camera).

The microdisplay device **136** is deployed with the image-emitting surface **140a** of the emissive-display **138** in the receiving portion **120** such that a portion (e.g., an edge portion) of the image-emitting surface **140a** contacts (or nearly contacts) a portion of a planar surface **119** that is coplanar with, or forms part of, the surface **118**. The planar surface **119** forms an edge on one side with the inner sidewall **134b**, and is bounded on the side opposite the edge by a projecting sidewall **122** (i.e., protruding rim or ridge) that projects outward from the surface **119** to form a step with the surface **119**. The surface **119** is bounded on its remaining sides by a projecting sidewall configuration **124**. In preferred embodiments, the deployment of the microdisplay device **136** is effectuated by adhesively attaching a mounting adapter element **144** (hexagonally shaped with a rectangular aperture) to the surface **140b** opposing the image-emitting surface **140a**. A layer (or layers) of adhesive may be applied to peripheral portions of the mounting adapter **144** so as to adhesively attach the mounting adapter **144** (with the emissive-display **138**) to the receiving portion **120**. The mounting adapter **144** may preferably be attached to the walls of the projecting sidewall configuration **124**. In the illustrated embodiment,

the projecting sidewall configuration **124** is implemented as a three-sided structure that projects outward from the surface **118**, and includes two parallel sidewalls **125a**, **125b** and a third sidewall **125c** that is perpendicular to the two sidewalls **125a**, **125b**, and that extends between the two parallel sidewalls **125a**, **125b** at end portions of the parallel sidewalls **125a**, **125b**. The  
5 sidewall **125c** may form part of the inner sidewall **134a**. The two parallel sidewalls **125a**, **125b** of the projecting sidewall configuration **124** also bound the projecting sidewall **122**, which extends between the two parallel sidewalls at end portions opposite from the third sidewall **125c** of the projecting sidewall configuration **124**. It is also noted that the projecting sidewall configuration **124** projects further out than the projecting sidewall **122**. The mounting adapter **144** may be  
10 adhesively attached to the sidewalls **125a**, **125b**, **125c**. The sidewalls **125a**, **125b**, **125c** terminate at respective coplanar surfaces **127a**, **127b**, **127c**.

Preferably, a cover member **146** (implemented, for example, as a substantially rectangular plate) is attached to the projecting sidewall configuration **124** after the emissive-display **138** is attached to the receiving portion **120** of the barrel **102**. In the illustrated  
15 embodiment, the cover member **146** includes a main (rectangular) body **148** and a flange **150** that projects from one of the sides of the main body **148** in a direction normal to the main body **148**. The flange **150** extends only partially across the length of the side of the main body **148** from which the flange **148** projects. In addition, the cover member **146** and the projecting  
20 sidewall configuration **124** are correspondingly configured, meaning that geometric shapes formed by the projections of the main body **148** and the projecting sidewall configuration **124** in the two-dimensional plane are identical (or nearly identical, within a small margin). When the cover member **146** is attached to the barrel **102**, the main body **148** is seated on the three surfaces  
25 **127a**, **127b**, **127c** of the projecting sidewall configuration **124**, and the flange **150** extends inward through the gap formed between the two parallel sidewalls **125a**, **125c** of the projecting sidewall configuration **124** and is aligned with the projecting sidewall **122**. A gap (or opening) is formed  
30 between the terminating surface of the flange **150** and the projecting sidewall **122**, that is of sufficient dimension to allow the electronic interfacing element **142** (connected at one end to the emissive-display **138**) to pass through the gap and out of the receiving portion **120** so as to connect (at another end thereof) to one or more electronic elements (e.g., power supply, display driver electronics, computerized storage, computerized processor, etc.).

The attachment of the base **600** and the cover **146** to the opposing ends **104**, **106** of the barrel **102** provide respective sealing engagements which seal the emissive-display **138** and the optical elements of the optical assembly **160** within the barrel **102**, thereby preventing environmental debris and/or contaminants from entering into the hollow interior portion of the

barrel **102** and contacting elements of the optical assembly **160**. The result is a modular and lightweight image projector **100**, which can be attached (i.e., optically coupled) to the remaining components of the optical system **40** (i.e., the LOE **50** and/or the optical coupling-in configuration **42**) as described above.

5           According to a particularly preferred but non-limiting implementation, several of the components of the image projector **100** are constructed from plastic material in order to provide a lightweight optical image projector **100**. In a preferred implementation, the barrel **102** and the optical components of the optical assembly **160** are constructed from plastic material (each component may be constructed from the same plastic material, or different plastic materials may  
10 be used to construct the different components). In another non-limiting implementation, one or more of the optical components of the optical assembly **160** is constructed from glass. In one non-limiting example, all of the components of the optical assembly **160** are constructed from glass. In preferred but non-limiting implementations, optical components of the optical assembly **160** (and in particular the lenses of the optical assembly **160**) are constructed from a material (or  
15 materials) that have a similar coefficient of thermal expansion so as to reduce the thermal stress of the optical assembly **160**, thereby reducing (and preferably altogether preventing) the chances of fracturing or deformation of the components of the image projector **100**.

As part of the process for constructing the image projector **100** according to embodiments of the present invention, a plurality of molds corresponding to the barrel **102** and the optical  
20 components of the optical assembly **160** are preferably obtained. Obtaining the molds may include producing (i.e., creating) the molds. The molds define the shape of the barrel **102** and the optical components, where each shape also includes the relevant engagement configurations and portions thereof (e.g., legs, protrusions, terminating regions, beveled grooves, beveled edges, surfaces, etc.). The components (i.e., barrel **102** and optical components of the optical assembly  
25 **160**) are then manufactured, for example in plastic, glass or polymer material, using the respective molds, by casting or injecting the plastic, glass or polymer material into the molds. The injected or casted molds are allowed to set, and the barrel **102** and optical components are then removed (ejected) from the molds. The optical components can then be deployed (i.e., stacked) in the barrel **102**, as described above.

30           Although the non-limiting embodiments of the engagement configurations described thus far have pertained to particular mechanical structures, such as beveled grooves, beveled edges, and surfaces, these structures are only exemplary. Other structures can be used, including non-beveled edges and grooves (although the bevels may reduce stress at the edges/grooves, preventing cracking/breaking of the optical components at the edges/grooves). Moreover,

although the engagement configurations in the described non-limiting embodiments have pertained to specific numbers of the correspondingly configured beveled edges and grooves, additional edges and grooves (beveled or non-beveled) may also be included to form part of one or more of the engagement configurations of the optical components.

5 In addition, although the non-limiting embodiments described have pertained to an image projector having an optical assembly consisting of four lenses, as previously mentioned other embodiments are possible in which fewer than four lenses or more than four lenses are deployed. In general, the size of the barrel, and in particular the hollow interior portion of the barrel should be designed to accommodate all of the lenses of the optical assembly. For example, when  
10 deploying an optical assembly utilizing five lenses, the barrel should be larger in size than the barrel **102** illustrated in the drawings.

Furthermore, although the embodiments described thus far have pertained to particular surface profiles of the lenses (e.g., aspheric, spheric), other surface profiles and combinations of surface profiles may be considered. In certain cases, the material from which the lenses are  
15 manufactured may contribute (at least in part) to the type of surface profile of the lenses that should be used. For example, when constructing the lenses from glass materials, the surface profiles of the surfaces **202, 204, 302, 304, 402, 404, 502, 504** may be chosen to be spheric surfaces.

The following paragraphs describe the propagation of light from the microdisplay device  
20 **136** through each of the optical components of the optical assembly **160**. Referring to FIGS. 16 – 19, it is noted that the presence of the base **600** allows the central optical axis of the lenses of the image projector **100** (extending from the center of the microdisplay device **136** through the center of each lens of the optical assembly **160**) to be positioned at an oblique angle relative to the major surfaces of the LOE **50** (due at least in part to the oblique positioning of the surface  
25 **604** relative to the surface **602**). In the configuration illustrated in FIGS. 16 – 19 (as well as many other configurations of the present invention), illumination from the image projector **100** is coupled into the LOE **50** at relative shallow angles (high angle of incidence) and emerges from the LOE **50** (i.e., is coupled out of the LOE **50**) close to perpendicular to the surface **52b**. Such a configuration inherently tends to generate chromatic aberration. The cross-sectional prism shape  
30 of the base **600** at least partially compensates for the chromatic aberration effects, by modifying the image illumination prior to the image illumination reaching the optical coupling-in configuration.

With particular reference to FIG. 19, there is shown a schematic representation of the traversal of light from the microdisplay device **136** through the optical assembly. Light waves

emitted by the microdisplay device **136**, represented schematically by the three sets of light rays **80A, 82A, 84A, 86A, 88A, 90A** corresponding to light emitted from three different regions of the microdisplay device **136**, are transmitted (and refracted) by the surfaces **202, 204** of the lens **200**, thereafter which they impinge on the lens pair **300, 400** and are transmitted (refracted) by the surfaces **302, 304, 402, 404** of the lenses **300, 400**, and after which they impinge on the collimating lens **500** and are transmitted (refracted) by the surfaces **502, 504** of the lens **500** to form three sets of parallel rays **80B, 82B, 84B, 86B, 88B, 90B** (i.e., rays **80B, 82B** are parallel, rays **84B, 86B** are parallel, and rays **88C, 90C** are parallel). As a result, light rays emanating from the same region (corresponding to like colors) of the microdisplay device **136** are generally parallel to each other (due to the collimation by the lens **500**). However, parallel light rays of one set may not necessarily be parallel to light rays of other sets (i.e., light rays **80B, 82B** are not necessarily parallel to light rays **84B, 86B**).

The collimated light waves (represented schematically by the three sets of parallel light rays **80B, 82B, 84B, 86B, 88B, 90B**) impinge on the base **600** (formed as a wedge/prism in the horizontal cross-sectional plane). The collimated light waves are refracted twice by the base **600** (once by each of the surfaces **602, 604**), and exit the image projector **100** (i.e., are transmitted out of the base **600** through the surface **604**) as image light waves (represented schematically by the three sets of parallel light rays **80C, 82C, 84C, 86C, 88C, 90C**, i.e., the rays **80C, 82C** are parallel, the rays **84C, 86C** are parallel, and the rays **88C, 90C** are parallel).

The image light waves that are output by the image projector **100** impinge on the optical coupling-in configuration **42** (implemented in FIGS. 17 and 18 as a reflective-type optical coupling-in configuration). As a result of the prism shape of the base **600** (i.e., the oblique angle between the surfaces **602, 604**) the different wavelengths of image light (from the microdisplay device **136**) that traverse through the surfaces **602, 604** of the base **600** are separated (i.e., dispersed) such that the base **600** at least partially compensates for the chromatic aberration introduced by the coupling-in (to the LOE **50**) and coupling-out (from the LOE **50**).

Turning now to another aspect of the present invention, various implementations of an optical coupling-in configuration that reduce the presence of ghost images (and stray light rays) will now be discussed with particular reference to FIGS. 33 – 36. By way of introduction, ghost images may occur when light rays corresponding to parts of the image are coupled out of the LOE at unwanted angles. When the optical coupling-in configuration **42** is implemented as a reflective surface (e.g., a mirror) deployed at the slant edge **56** of the LOE **50** (as illustrated in FIG. 2), multiple reflections of light rays (emanating from the image projector **100**) at the

reflective surface (i.e., at the slant edge **56**) may result in the coupling out of image light rays from the LOE **50** at such unwanted angles.

Referring first to FIG. 33, there is shown an optical coupling-in configuration **42** that reduces ghost images and stray light rays according to an embodiment of the present invention.

5 The optical coupling-in configuration **42** includes a plate **70** formed from transparent material (i.e., the plate **70** is a light-transmitting substrate) and having parallel external surfaces (faces) **72a**, **72b** as well as external surfaces (also referred to as “edges”) **74a**, **74b**. In the non-limiting implementation illustrated in the drawings, the surfaces/edges **74a**, **74b** are also parallel, such that the two pairs of parallel external surfaces **72a**, **72b**, **74a**, **74b** form a rectangular cross-  
10 section. It is noted, however, that the surfaces **74a**, **74b** need not be parallel. For example, the length of the surface **72b** may be less than the length of the surface **72a**, such that the surfaces **74a**, **74b** are non-parallel. The plate **70** is deployed with surface **72a** at the slant edge **56** such that surface **72a** overlies and is coincident with the slant edge **56**. In certain preferred but non-limiting embodiments, the coupling configurations **636a**, **636b** are configured to optically couple  
15 (via adhesive or mechanical attachment) the base **600** to portions of the edge surface **74b**. FIGS. 17 and 18 are top and bottom views, respectively, that illustrate the coupling configurations **636a**, **636b** in contact with respective portions of the surface **74b**.

In certain embodiments, the plate **70** is optically coupled to the LOE **50** by adhesive attachment, for example, by applying a layer of optical cement between the surface **72a** and the  
20 edge **56**. In other embodiments, the optical coupling between the plate **70** and the LOE **50** is effectuated mechanically via a mechanical module or mechanical assembly that positions the plate **70** adjacent to the slant edge **56** (preferably without an air gap between the surface **72a** and the slant edge **56**). The plate **70** and the LOE **50** are preferably constructed from the same type of material so as to ensure that the plate **70** and the LOE **50** have same index of refraction. When  
25 using an adhesive to optically attach the plate **70** to the LOE **50**, the adhesive is preferably an index-matching material.

The surface **72b** is a reflective surface (e.g., a mirror), which may be formed from a surface of the plate **70** that is coated with one or more layers of coating. In certain embodiments, the coating is a reflective coating, such as a dielectric coating, or a metallic coating (in which the  
30 reflective surface **72b** is implemented as a “silver mirror”), that reflects light waves emitted by the image projector **100**. In other embodiments, the coating may be an angular selective coating, such that the surface **72b** only reflects light from the image projector **100** that impinges on the surface **72b** at a prescribed range of angles of incidence. In another embodiment, a simple mirror can be deployed at the surface **72b** external to the plate **70**.

In order to prevent stray light rays (that may be manifested as ghost images at the output of the LOE) from entering the LOE **50**, a light absorber material is preferably deployed at the surface (edge) **74a** of the plate **70**. The light absorber material may be deployed at the other surface **74b** as well, however, it is the deployment of the light absorber material at the surface **74a** which has the most significant effect on prevention of stray light rays from entering the LOE **50**. These stray light rays include light rays that, if not for the presence of the plate **70**, would otherwise be reflected twice by the slant edge **56** and coupled into the LOE **50**. However, in the presence of the plate **70**, light rays that would have been reflected twice by the slant edge **56** are instead absorbed by the light absorber material. The light absorber material is configured to absorb the majority of the intensity of light in the optical spectrum of light that is emitted by the image projector **100** (i.e., the visible light spectrum). Light absorbing materials are well-known in the art and are readily commercially available.

FIG. 34 shows an enlarged view of a portion of FIG. 33 to illustrate the effect of the plate **70** with the light absorber material on light rays injected (introduced) by the image projector **100**. Sample light rays **54a** and **54b** (which are two of the light rays that span the beam **54**) are reflected from the surface **72b** and enter the LOE **50**, as intended. Another sample light ray **54c** (being another one of the light rays that spans the beam **54**) is representative of unwanted light that would otherwise enter the LOE **50** in the absence of the plate **70**. In the absence of the plate **70**, the light ray **54c** impinges on the slant edge **56** (similar to as in FIG. 2). The light ray **54c** is reflected by the slant edge **56** (which acts as the optical coupling-in configuration, implemented as a reflective surface), generating reflected light ray **55c** (represented by the dashed arrow). The reflected light ray **55c** impinges on the surface **52b** of the LOE **50**, where the light ray **55c** undergoes internal reflection from the surface **52b** thereby generating reflected light ray **55d**. The reflected light ray **55d** is then reflected by the slant edge **56**, generating reflected light ray **55e** which is eventually coupled out as a ghost light ray toward the eye of the viewer **68** by the optical coupling-out configuration **62**. Note that the light ray **55e** may be coupled out of the LOE **50** before undergoing further internal reflections from the surfaces **52a**, **52b**, or may undergo one or more internal reflections from the surfaces **52a**, **52b** prior to being coupled out of the LOE **50** by the optical coupling-out configuration **62**.

In the presence of the plate **70**, however, the light ray **54c** is transmitted by the slant edge **56** and the surface **72a**, and impinges on the surface **72b**. The light ray **54c** is reflected by the surface **72b**, generating reflected light ray **57c**. The reflected light ray **57c** is transmitted by the surfaces **72a**, **56** and impinges on the surface **52b** of the LOE **50**, where the light ray **57c** undergoes internal reflection from the surface **52b** thereby generating reflected light ray **57d**. The

reflected light ray **57d** is transmitted by the surfaces **56**, **72a** and impinges on the surface **74a** which absorbs the light ray **57d** (due to the light absorber material), thereby providing extinction of the potential ghost light ray. As a result of the presence of the plate **70** with the absorber material, the light ray **54c** is not ultimately coupled into the LOE **50**, and therefore is not coupled  
5 out of the LOE **50** (by the optical coupling-out configuration **62**) toward the eye **68** of the viewer.

The thickness of the plate **70** (measured as the distance between the surfaces **74a**, **74b**) that is to be prescribed may be determined by performing analyses of the optical design and manufacturing process. For example, a preferable prescribed thickness may be calculated by  
10 performing a quantitative analysis on the number of ghost rays that occur based on the angle of the slant edge **56** and the incident angles of injected illumination **54**. However, manufacturing considerations may or may not support the preferable thickness determined by the quantitative analysis. In certain non-limiting implementations, the prescribed thickness is a fraction of the thickness of the LOE **50**, for example no more than half of the LOE thickness.

15 It is noted that in an alternative embodiment, a diffusive element (e.g., a light diffuser) can be deployed at the surface **74a** instead of the light absorber material. The diffusive element scatters light that is incident to the surface **74a** (e.g., light ray **57d**), such that the scattered light exits out of the plate **70** via the surface **74a**. Note, however, that some of the scattered light may be reflected back and enter the LOE **50**.

20 Referring now to FIG. 35, there is show an optical coupling-in configuration **42** for reducing ghost images and stray light rays according to another embodiment of the present invention. In this embodiment, the optical coupling-in configuration **42** includes a pair of preferably (but not necessarily) parallel surfaces **82**, **84**. The surface **82** is a reflective surface (e.g., a mirror), which in preferred embodiments is formed from a surface that is coated with one  
25 or more layer of metallic coating. In such embodiments, the surface **82** is preferably a silver mirror. The surface **84**, deployed in the optical path between the surface **82** and the optical coupling-out configuration **62**, is a selectively reflective (also selectively transmissive) surface, preferably an angular selective reflective surface. In preferred embodiments, the surface **84** is formed from a surface coated with one or more layer of dielectric coating. The dielectric coating  
30 is designed such that the surface **84** reflects light impinging on the surface **84** at shallow angles (large angles of incidence, measured relative to the normal to the surface **84**), and transmits light impinging on the surface at steep angles (small angles of incidence, measured relative to the normal to the surface **84**). As a result, light from the image projector **100** that is reflected from the surface **82**, that impinges on the surface **84** at a range of shallow angles is reflected by the

surface **82**. Preferably, these reflected light rays impinge on the surface **52a** of the LOE **50** at an angle less than the critical angle required to trap light between the surfaces **52a**, **52b** by total internal reflection, such that the reflected light rays exit the LOE **50** (and therefore do not propagate by internal reflection from the surfaces **52a**, **52b**, and therefore are not coupled out of the LOE **50** by the optical coupling-out configuration **62**). Light from the image projector **100** that is reflected from the surface **82**, and that impinges on the surface **84** at a range of steep angles is transmitted by the surface **82**. These transmitted light rays enter the LOE **50** at a trajectory whereupon the angle of incidence at which they impinge upon the surfaces **52a**, **52b** is greater than the critical angle required to trap light between the surfaces **52a**, **52b** by total internal reflection. As a result, these light rays propagate through the LOE **50** by internal reflection and are ultimately coupled out of the LOE **50** by the optical coupling-out configuration **62**.

In certain non-limiting implementations, the slant edge **56** of the LOE **50** may be coated with the coating so as to form the surface **82**. In such an implementation, an additional surface, deployed in the LOE **50** downstream from the surface **82** and upstream from the optical coupling-out configuration **62** is coated with the dielectric coating to form the surface **84**. In another non-limiting implementation, the slant edge **56** of the LOE **50** may be coated with the dielectric coating to form the surface **84**. In such an implementation, a block of light-transmitting material (formed as a parallelogram and dimensioned with a thickness similar to the thickness of the LOE **50**) may be optically attached (e.g., via optical cement or via a mechanical module) to the LOE **50** at the slant edge **56**. The surface of the block of light-transmitting material that is parallel to the slant edge **56** may be coated with the metallic coating to form the surface **82**. In another non-limiting implementation, a block of light-transmitting material (formed as a parallelogram and dimensioned with a thickness similar to the thickness of the LOE **50**) may be provided with dielectric and metallic coatings on parallel surfaces so as to form the surfaces **82** and **84**, respectively. The block of light-transmitting material may then be optically attached (e.g., via optical cement or via a mechanical module) to the LOE **50** such that the surface **82** is cemented to the slant edge **56** or positioned adjacent to the slant edge **56**.

As mentioned above, the cross-sectional wedge/prism geometry of the base **600** enables the placement of the image projector **100** relative to the LOE **50** at an angle  $\theta_{\text{proj}}$ . The major components of the optical system (i.e., the optical coupling-in configuration **42**, the LOE **50**, and the image projector **100**) are designed so as to have a deployment angle  $\theta_{\text{proj}}$  such that light rays emitted by the image projector **100** impinge on the major external surface **52b** at oblique angles (prior to reaching the optical coupling-in configuration **42** (for example as shown in FIGS. 33 –

36). When implementing the optical coupling-in configuration according to the embodiment described with reference to FIG. 35, the deployment angle  $\theta_{\text{proj}}$  and the angle ( $\alpha_{\text{edge}}$ ) of the slant edge **56** should be considered when designing the dielectric coating that is used to form the surface **84**. For the non-limiting case of  $\theta_{\text{proj}} = 120^\circ$  and  $\alpha_{\text{edge}} = 72^\circ$ , a range of angles of incidence (measured normal to the surface **84**) at which the dielectric coating reflects light and transmits light, respectively, that has been found to be particularly effective for reducing ghost images is  $51^\circ - 66^\circ$  and  $15^\circ - 30^\circ$ .

FIG. 36 shows an enlarged view of a portion of FIG. 35 to illustrate the effect of the surfaces **82**, **84** on light rays injected (introduced) by the image projector **100**. Sample light rays **54a** and **54b** (which are two of the light rays that span the beam **54**) are reflected from the surface **82** as light rays **59a** and **59b**. The light ray **59b** undergoes internal reflection at the surface **52b** thereby generating reflected light ray **61b**. The reflected light ray **61b** undergoes internal reflection from the surface **52a** thereby generating reflected light ray **63b**. The light rays **59a** and **63b** are both incident to the surface **84** at angles of incidence that are within the transmission angular range (e.g.,  $15^\circ - 30^\circ$ ) such that the light rays **59a** and **63b** are transmitted by the surface **84** and enter the LOE **50** as intended (where they continue propagating by internal reflection and are coupled out by the optical coupling-out configuration **62**).

Another sample light ray **54c** (being another one of the light rays that spans the beam **54**) is representative of unwanted light that would otherwise enter the LOE **50** in the absence of the surface **84**. The light ray **54c** is reflected by the surface **82** as reflected light ray **59c**. The light ray **59c** undergoes internal reflection at the surface **52b** thereby generating reflected light ray **61c**. The reflected light ray **61c** is reflected by the surface **82** thereby generating reflected light ray **63c**. The reflected light ray **63c** impinges on the surface **84** at an angle of incidence that is within the reflection angular range (e.g.,  $51^\circ - 66^\circ$ ) such that the light ray **63c** is reflected by the surface **84** as reflected light ray **65c** toward the major surface **52a** of the LOE **50**. The reflected light ray **65c** impinges on the surface **52a** at an angle that is less than the critical angle required for maintaining conditions for total internal reflection, and is therefore transmitted out of the LOE **50** via the surface **52a**.

The techniques for combatting ghost images and stray light described thus far have relied on optical coupling-in configuration design approaches that prevent light, emitted by the image projector **100**, from being coupled into the LOE **50** at unwanted angles. Other approaches are possible, which can be used in combination with, or instead of, the approaches described above, which rely on designing the components of the image projector **100** in a way which reduces the amount of light that is output by the image projector **100** at unwanted angles, which can manifest

as ghost images at the LOE output. It has been found that unwanted reflections from the sidewalls of the optical components (in particular the lenses) of the optical assembly **160** and/or the inner sidewalls of the barrel **102** can contribute to the effects of outputting light from the image projector **100** at unwanted angles. Since the optical components (and the barrel) are  
5 manufactured using specially designed molds (as discussed above), the molds can be designed in a way that reduces or altogether prevents these unwanted reflections. One method of handling the unwanted reflections is to design the lens (**200, 300, 400, 500**) molds with a particularly located parting line at a preferred prescribed sidewall angle.

With particular reference to FIGS. 13, 14 and 16, it can be seen that the side surfaces **206, 10 208, 306, 308, 406, 408, 506, 508** are tapered inward to define side surface angles for the lenses **200, 300, 400, 500** of  $\theta_{\text{Lens200}}$ ,  $\theta_{\text{Lens300}}$ ,  $\theta_{\text{Lens400}}$ ,  $\theta_{\text{Lens500}}$ , respectively. In this particular non-limiting example, the molds used to manufacture the lenses **200, 300, 400, 500** have a bottom parting line (in this context, “bottom” being closer to the optical surface of the lens that is farther from the base **600**), with a side surface angle of approximately  $8^\circ$ . The sidewall angles  $\theta_{\text{Lens200}}$ ,  
15  $\theta_{\text{Lens300}}$ ,  $\theta_{\text{Lens400}}$ ,  $\theta_{\text{Lens500}}$  are measured as the angle between the side surface (e.g., **206, 208, 306, 308, 406, 408, 506, 508**) and a line parallel to the shared central optical axis of the lenses (which is the vertical axis in FIG. 13, and is along the normal to the plane of the microdisplay device **136**). The bottom parting line and relatively small side surface angle enable the manufactured lenses to be extracted from the molds with general ease. In addition, it has been found that this  
20 particular parting line and sidewall angle configuration of the molds significantly reduces the number of reflections from the side surfaces **206, 208, 306, 308, 406, 408, 506, 508**, as compared with alternative parting line and sidewall angle configurations.

One such alternative parting line and sidewall angle configuration of molds contemplated herein is a configuration having a center parting line, resulting in each lens having sidewall  
25 surfaces formed from a pair of segments. In this configuration, the side surface segments form a sidewall angle of approximately  $2^\circ$ . Although this alternative configuration has advantages in the ease with which the lenses can be removed from the molds (due to the center parting line and small sidewall angle), the lens side surface segments impart a considerable number of unwanted reflections which introduce an appreciable amount of stray light rays.

30 In certain instances, a proportion of the intensity of light that is incident to one (or more) lens of the optical assembly **160** may be transmitted out of the lens via the side surface of the lens (or the top or bottom portion of the lens) so as to exit the lens (and exit the optical assembly **160**). Light that exits the side surface of a lens impinges on the inner sidewall **134a, 134b** or region **130a, 132a, 130b, 132b** that is proximate to the light-exiting side surface of the lens. The

impinging light may be reflected by the inner sidewall **134a**, **134b** or region **130a**, **132a**, **130b**, **132b** back toward the lenses and re-enter the optical assembly **160** as stray light rays, causing distortion of the image that is to be injected into the LOE **50**. In order to prevent unwanted reflections from the inner sidewalls **134a**, **134b** or regions **130a**, **132a**, **130b**, **132b**, the barrel **102** itself can also be designed with specialized inner sidewalls that reduce unwanted reflections from interior sidewall portions of the barrel **102**.

In certain embodiments, one or more of the inner sidewalls **134a**, **134b** or regions **130a**, **132a**, **130b**, **132b** are coated with a light absorbing coating that prevents light from re-entering through the side surfaces of one or more of the lenses **200**, **300**, **400**, **500**. In addition to, or instead of the coating, one or more of the inner sidewalls **134a**, **134b** or regions **130a**, **132a**, **130b**, **132b** can be provided with a pattern, such as a corrugated pattern (e.g., a zig-zag type pattern), to prevent unwanted reflections. The pattern may be provided on the aforementioned sidewalls or regions of the barrel **102** by utilizing a specially designed mold, having the corresponding shape of the barrel **102** with the patterned sections, to manufacture the barrel **102**. As a result of the patterned sidewalls and/or regions, light that exits out of the side surfaces of one or more of the lenses **200**, **300**, **400**, **500** may impinge on a portion of the patterned surface/region at an angle so as to reflect the light at a reflected angle that prevents the reflected light from re-entering through the side surfaces of one or more of the lenses **200**, **300**, **400**, **500**. Preferably the zig-zag pattern at the sidewalls **134a**, **134b** corresponds to the general outline shape of the nested configuration of the lenses **200**, **300**, **400**, **500** (described above with reference to FIG. 15), such that the zig-zag pattern generally follows the shape of the legs **310a**, **310b**, **410a**, **410b**, **510a**, **510b**. This prevents light from re-entering the lenses through the surfaces **312a**, **312b**, **412a**, **412b**, **512a**, **512b**.

It is noted that throughout the present disclosure wherever light is referred to as being trapped within the LOE by internal reflection, the internal reflection may be in the form of total internal reflection, whereby propagating image illumination that is incident at the major external surfaces **52a**, **52b** of the substrate (LOE) at angles greater than a critical angle causes reflection of the illumination at the major external surfaces **52a**, **52b**. Alternatively, the internal reflection may be effectuated by a reflective coating (e.g., an angularly selective reflective coating) applied to the major external surfaces **52a**, **52b** such that propagating image illumination that is incident to the major external surfaces within a given angular range defined by the coating is reflected at the major external surfaces **52a**, **52b**.

Although only the structure of the image projector, LOE, and optical coupling-in configuration is illustrated in most of the drawings, it will be understood that the optical system

according to the embodiments of the present invention is intended for use as part of a display, typically a head-up display, which is preferably a near-eye display such as a head-mounted display or an eyeglasses-frame supported display (i.e., eye-glasses form factor). In particularly preferred embodiments, the optical system is implemented as part of an eyeglasses-frame supported display. In such implementations, the geometry of the lenses of the optical assembly enables the image projector **100** to be advantageously attached to the eyeglasses-frame so as to be mounted to a temple portion of the eyeglasses-frame, providing the user with a comfortable wearable head-mounted and compact optical device.

The descriptions of the various embodiments of the present disclosure have been presented for purposes of illustration, but are not intended to be exhaustive or limited to the embodiments disclosed. Many modifications and variations will be apparent to those of ordinary skill in the art without departing from the scope and spirit of the described embodiments. The terminology used herein was chosen to best explain the principles of the embodiments, the practical application or technical improvement over technologies found in the marketplace, or to enable others of ordinary skill in the art to understand the embodiments disclosed herein.

As used herein, the singular form, “a”, “an” and “the” include plural references unless the context clearly dictates otherwise.

The word “exemplary” is used herein to mean “serving as an example, instance or illustration”. Any embodiment described as “exemplary” is not necessarily to be construed as preferred or advantageous over other embodiments and/or to exclude the incorporation of features from other embodiments.

It is appreciated that certain features of the invention, which are, for clarity, described in the context of separate embodiments, may also be provided in combination in a single embodiment. Conversely, various features of the invention, which are, for brevity, described in the context of a single embodiment, may also be provided separately or in any suitable subcombination or as suitable in any other described embodiment of the invention. Certain features described in the context of various embodiments are not to be considered essential features of those embodiments, unless the embodiment is inoperative without those elements.

To the extent that the appended claims have been drafted without multiple dependencies, this has been done only to accommodate formal requirements in jurisdictions which do not allow such multiple dependencies. It should be noted that all possible combinations of features which would be implied by rendering the claims multiply dependent are explicitly envisaged and should be considered part of the invention.

**WO 2021/117033****PCT/IL2020/051259**

Although the invention has been described in conjunction with specific embodiments thereof, it is evident that many alternatives, modifications and variations will be apparent to those skilled in the art. Accordingly, it is intended to embrace all such alternatives, modifications and variations that fall within the spirit and broad scope of the appended claims.

WHAT IS CLAIMED IS:

1. An optical system, comprising:  
a hollow mechanical body including first and second ends;  
an optical assembly including a plurality of optical components arranged in a stack configuration, each of the optical components including a set of engagement configurations, wherein for each pair of adjacent optical components in the stack configuration at least some of the engagement configurations of a first optical component in the pair are configured to engage with at least some of the engagement configurations of a second optical component in the pair, and wherein some of the engagement configurations of the optical component at a first end of the stack configuration are configured to engage with corresponding engagement configurations of the hollow mechanical body at the first end of the hollow mechanical body so as to position the other optical components of the stack configuration within the hollow mechanical body; and  
an emissive display device deployed at the second end of the hollow mechanical body.
  
2. The optical system of claim 1, wherein the engagement configurations of the optical component at the first end of the stack configuration includes at least a pair of outwardly projecting flanges, and wherein the engagement configurations at the first end of the hollow mechanical body includes a pair of channels configured to receive the projecting flanges.
  
3. The optical system of claim 1, wherein the hollow mechanical body further includes an inner sidewall configuration, and wherein at least one of the optical components includes at least one rotation limiting configuration, wherein the rotation limiting configuration and the inner sidewall configuration cooperate to limit an amount of rotation of the optical assembly about one or more rotational axes.

4. The optical system of claim 1, wherein the second end of the hollow mechanical body includes: a receiving portion for receiving the emissive display device, and an outwardly projecting sidewall configuration.

5. The optical system of claim 1, further comprising: a cover member deployed at the outwardly projecting sidewall configuration of the second end of the hollow mechanical body.

6. The optical system of claim 1, wherein the hollow mechanical body is tapered from the first end to the second end.

7. The optical system of claim 1, wherein the one of the optical components has a substantially wedge-shaped cross-section.

8. The optical system of claim 1, wherein the plurality of optical components includes a set of lenses.

9. The optical system of claim 8, wherein the set of lenses includes exactly four lenses.

10. The optical system of claim 8, wherein the set of lenses includes fewer than four lenses.

11. The optical system of claim 8, wherein the set of lenses includes more than four lenses.

12. The optical system of claim 1, wherein the emissive display device includes an organic light emitting diode display.

13. The optical system of claim 1, wherein the emissive display device includes micro light emitting diode display.

14. The optical system of claim 1, wherein the optical component at the first end of the stack configuration is adhesively attached to the first end of the hollow mechanical body.

15. The optical system of claim 1, wherein the engagement configuration of the optical component at the first end of the stack configuration maintains the other optical components within the hollow mechanical body without the use of adhesive applied to any of the other optical components.

16. The optical system of claim 1, wherein the other optical components are coaxially positioned within the hollow mechanical body.

17. The optical system of claim 1, wherein at least one of the optical components of the optical assembly is constructed from a plastic material.

18. The optical system of claim 1, wherein all of the optical components of the optical assembly are constructed from a plastic material.

19. The optical system of claim 1, wherein the hollow mechanical body is constructed from a plastic material.

20. The optical system of claim 1, wherein the emissive display device is configured to generate light corresponding to an image, and wherein the optical assembly is configured to receive light from the emissive display device and output image light for coupling into a light-transmitting substrate.

21. The optical system of claim 1, further comprising: a light-guide substrate having at least two major surfaces parallel to each other and a light-wave input aperture optically coupled to the first of the optical components via an optical coupling-in configuration.

22. The optical system of claim 21, wherein the first of the optical components has a prism-shaped cross-section and is configured to modify image light from the emissive display device prior to the image light reaching the optical coupling-in configuration so as to at least partially compensate for chromatic aberration.

23. The optical system of claim 1, wherein the hollow mechanical body further includes an inner sidewall configuration that is configured to reduce reflections of light transmitted by the optical components from interior portions of the hollow mechanical body.

24. An optical system, comprising:

a hollow mechanical body including first and second ends;

an optical assembly including a base optical element and a plurality of lens optical elements arranged in a stack configuration with the base optical element at a first end of the stack configuration and the lens optical elements deployed within the hollow mechanical body, each of the optical elements of the optical assembly including a set of engagement configurations, wherein for each pair of adjacent optical elements in the stack configuration at least some of the engagement configurations of a first optical element in the pair are configured to engage with at least some of the engagement configurations of a second optical element in the pair, and wherein some of the engagement configurations of the base optical element are configured to engage with corresponding engagement configurations at the first end of the hollow mechanical body so as to position the lens optical elements within the hollow mechanical body; and

an emissive display device deployed at the second end of the hollow mechanical body configured to generate light corresponding to an image for propagating through the optical assembly.

25. The optical system of claim 24, further comprising: a light-guide substrate having at least two major surfaces parallel to each other and an optical coupling region,

wherein the base optical element is optically coupled to the optical coupling region and to an optical coupling-in configuration configured for coupling image light from the optical assembly into the light-guide substrate.

26. The optical system of claim 25, wherein the base optical element has a prism-shaped cross-section and is configured to modify image light from the emissive display device prior to the image light reaching the optical coupling-in configuration so as to at least partially compensate for chromatic aberration.

27. A method for constructing an optical system, comprising:  
obtaining a hollow mechanical body that includes a first end and a second end,  
the first end having a set of engagement configurations;  
molding a plurality of optical components using a corresponding plurality of molds that define a shape of the optical components, each shape including a set of engagement configurations;  
deploying the optical components in a stack configuration with at least a portion of the stack configuration within the hollow mechanical body, wherein for each pair of adjacent optical components in the stack configuration at least some of the engagement configurations of a first optical component in the pair engage with at least some of the engagement configurations of a second optical component in the pair, and wherein some of the engagement configurations of the optical component at a first end of the stack configuration engage with the engagement configurations at the first end of the hollow mechanical body so as to maintain the portion of the stack within the hollow mechanical body;  
and  
deploying an emissive display device at the second end of the hollow mechanical body.

28. The method of claim 27, wherein the molding includes casting or injecting a plastic material into the molds.

29. The method of claim 27, wherein obtaining the hollow mechanical body includes, obtaining a mold defining a shape the hollow mechanical body, and casting or injecting a material into the mold defining the shape the hollow mechanical body.

30. The method of claim 27, further comprising: applying adhesive between the optical component at the first end of the stack configuration and at least one portion of the first end.

31. The method of claim 27, wherein the hollow mechanical body is tapered from the first end to the second end.

32. The method of claim 27, wherein the second end of the hollow mechanical body includes a receiving portion for receiving the emissive display device, and an outwardly projecting sidewall configuration, the method further comprising: deploying a cover member at the outwardly projecting sidewall configuration of the second end of the hollow mechanical body.

33. The method of claim 32, wherein the optical component at the first end of the stack configuration and the cover member cooperate to seal the hollow mechanical body so as to substantially prevent environmental debris from contacting the optical components deployed within the hollow mechanical body.

34. The method of claim 27, further comprising: adhesively attaching a mounting adapter to the emissive display device; and adhesively attaching the mounting adapter to a portion of the second end of the hollow mechanical body.

35. The method of claim 34, further comprising: aligning the emissive display device with the optical components prior to adhesive attachment of the mounting adapter to the portion of the second end of the hollow mechanical body.

36. The method of claim 27, wherein the molds have parting lines that produce sidewall geometries of the respective optical components that reduce reflections of

light, transmitted by the optical components, from interior portions of the hollow mechanical body.

37. The method of claim 27, wherein the hollow mechanical body further includes an inner sidewall configuration that is configured to reduce reflections of light, transmitted by the optical components, from interior portions of the hollow mechanical body

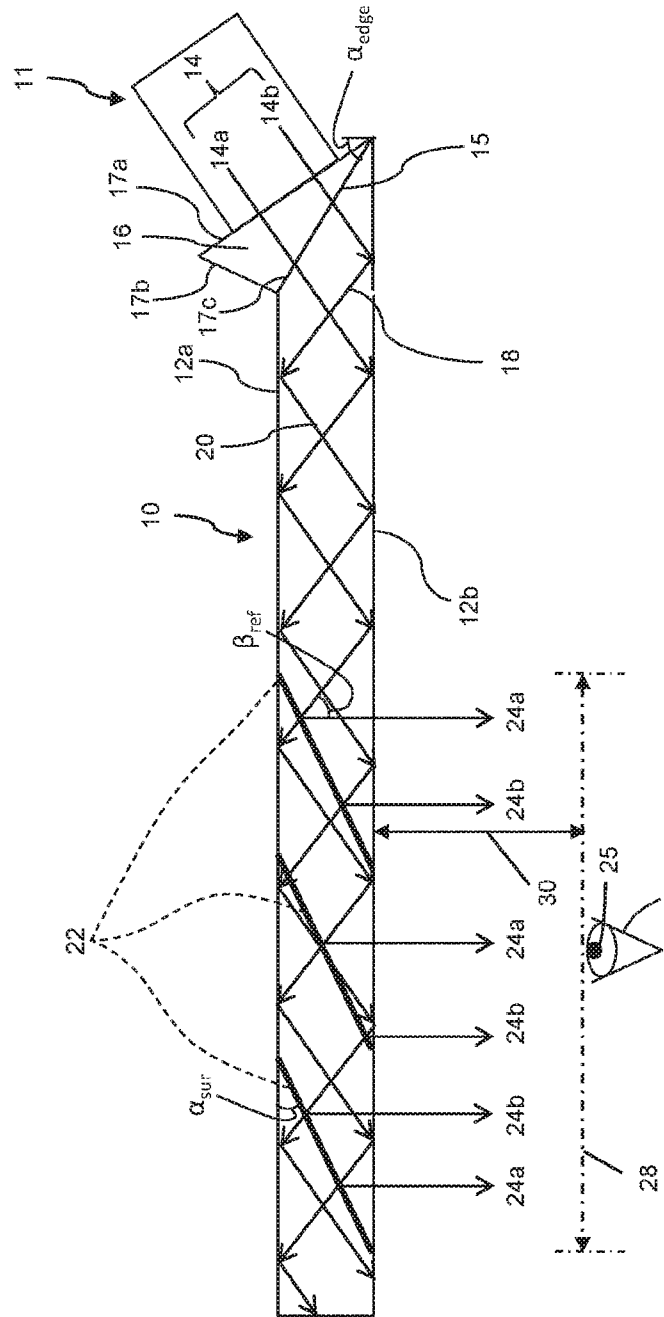

FIG. 1 (PRIOR ART)

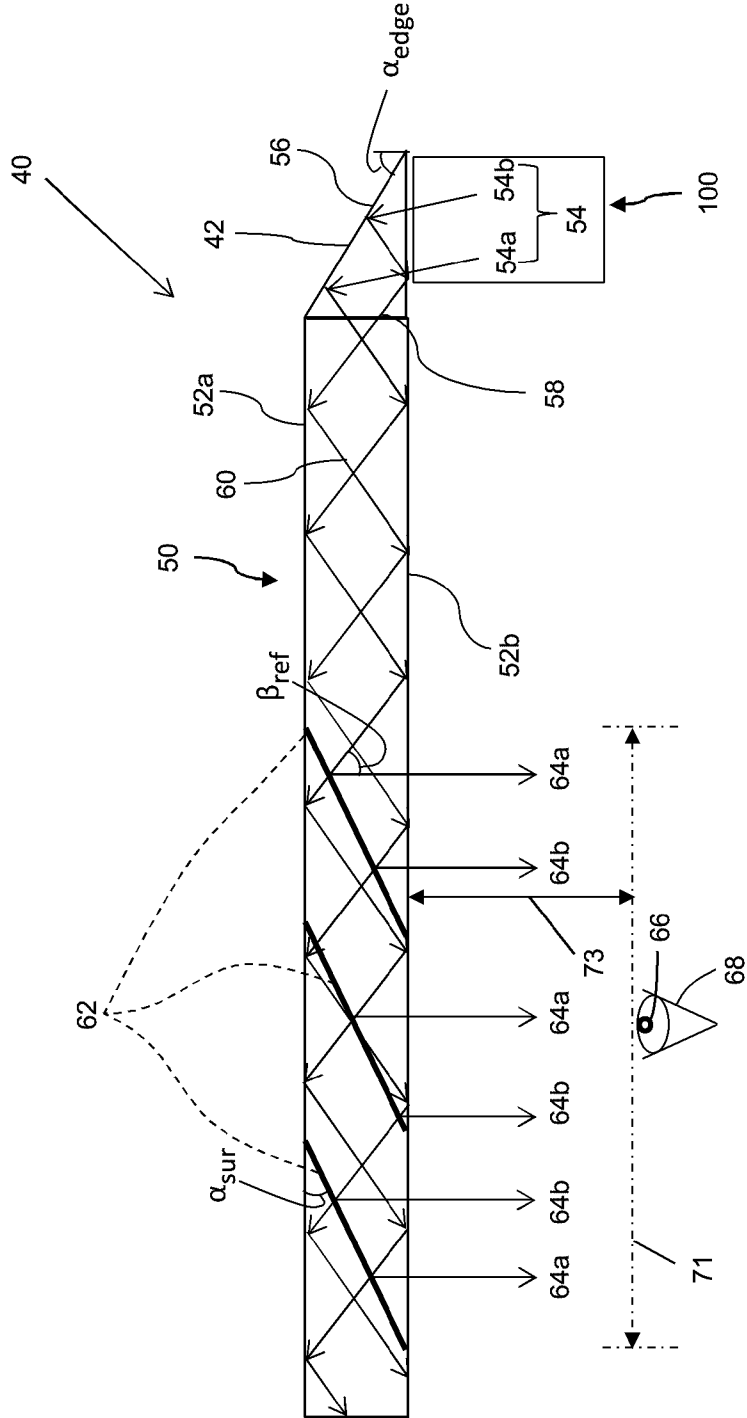

FIG. 2

3/27

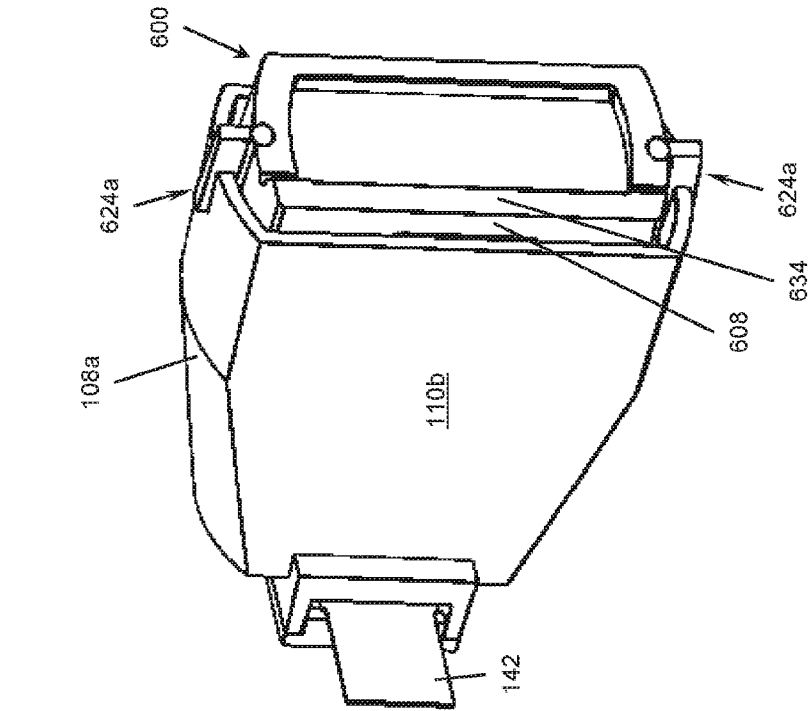

FIG. 3

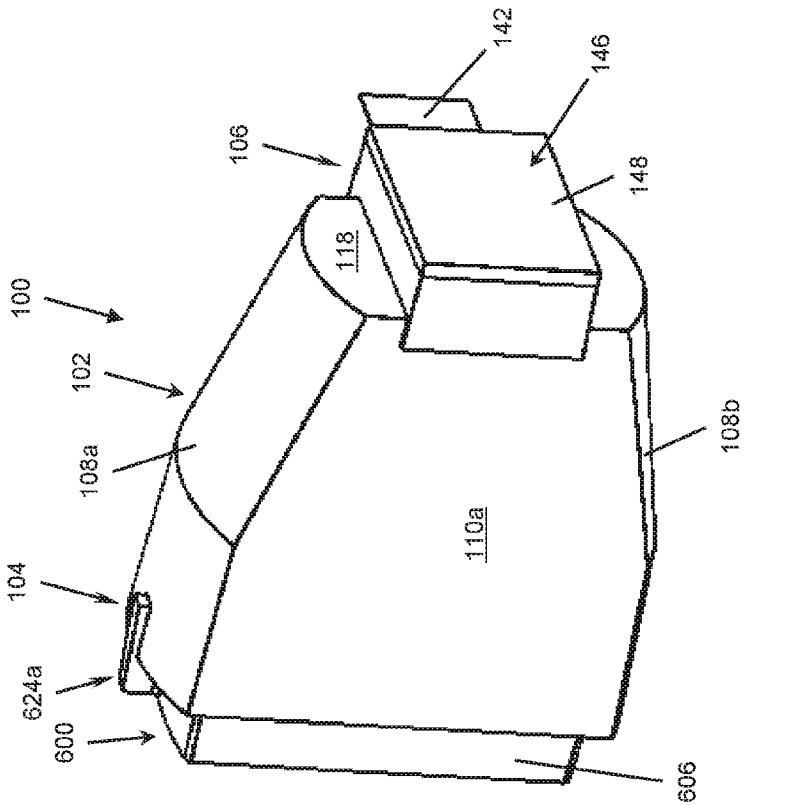

FIG. 4

4/27

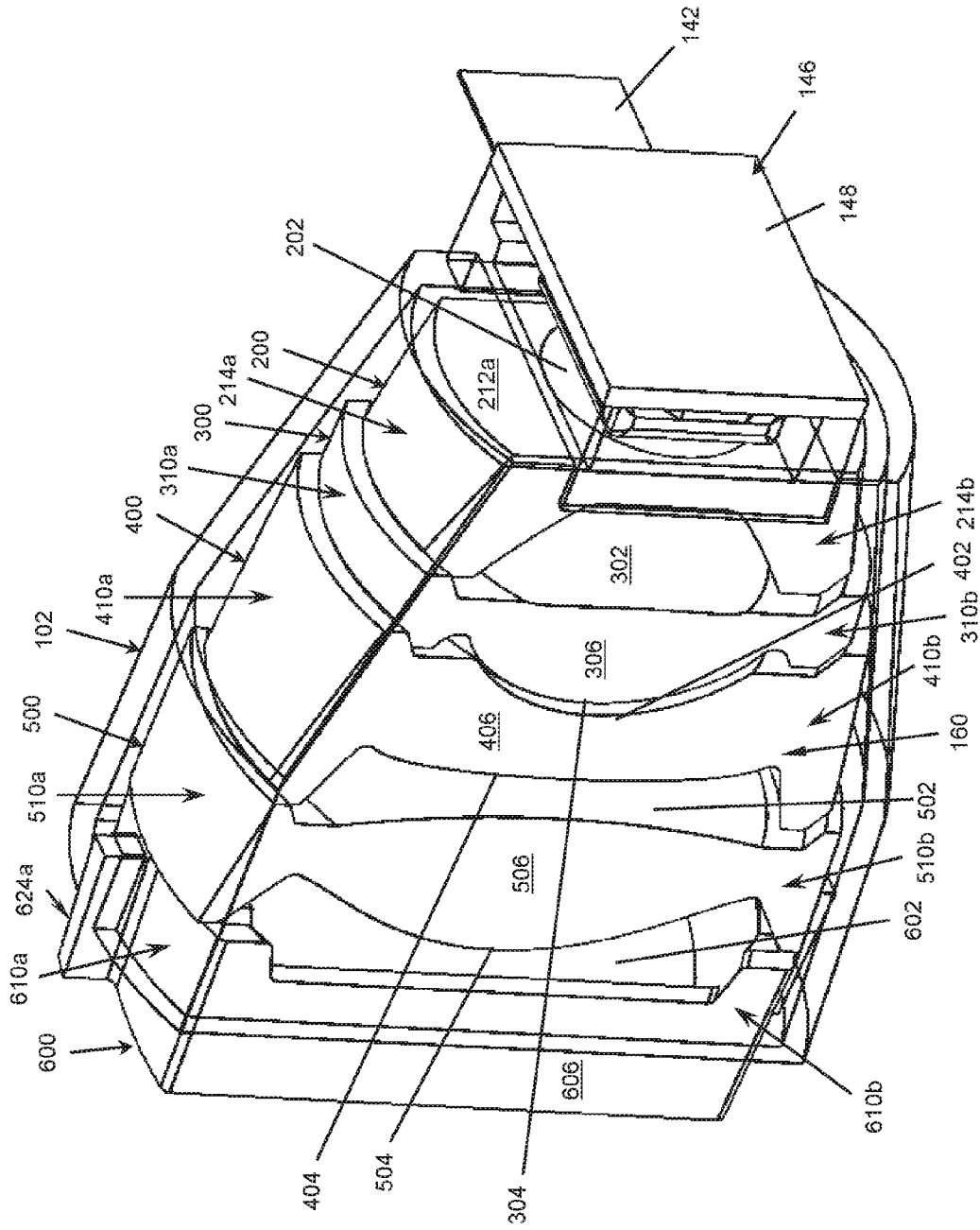

FIG. 5

5/27

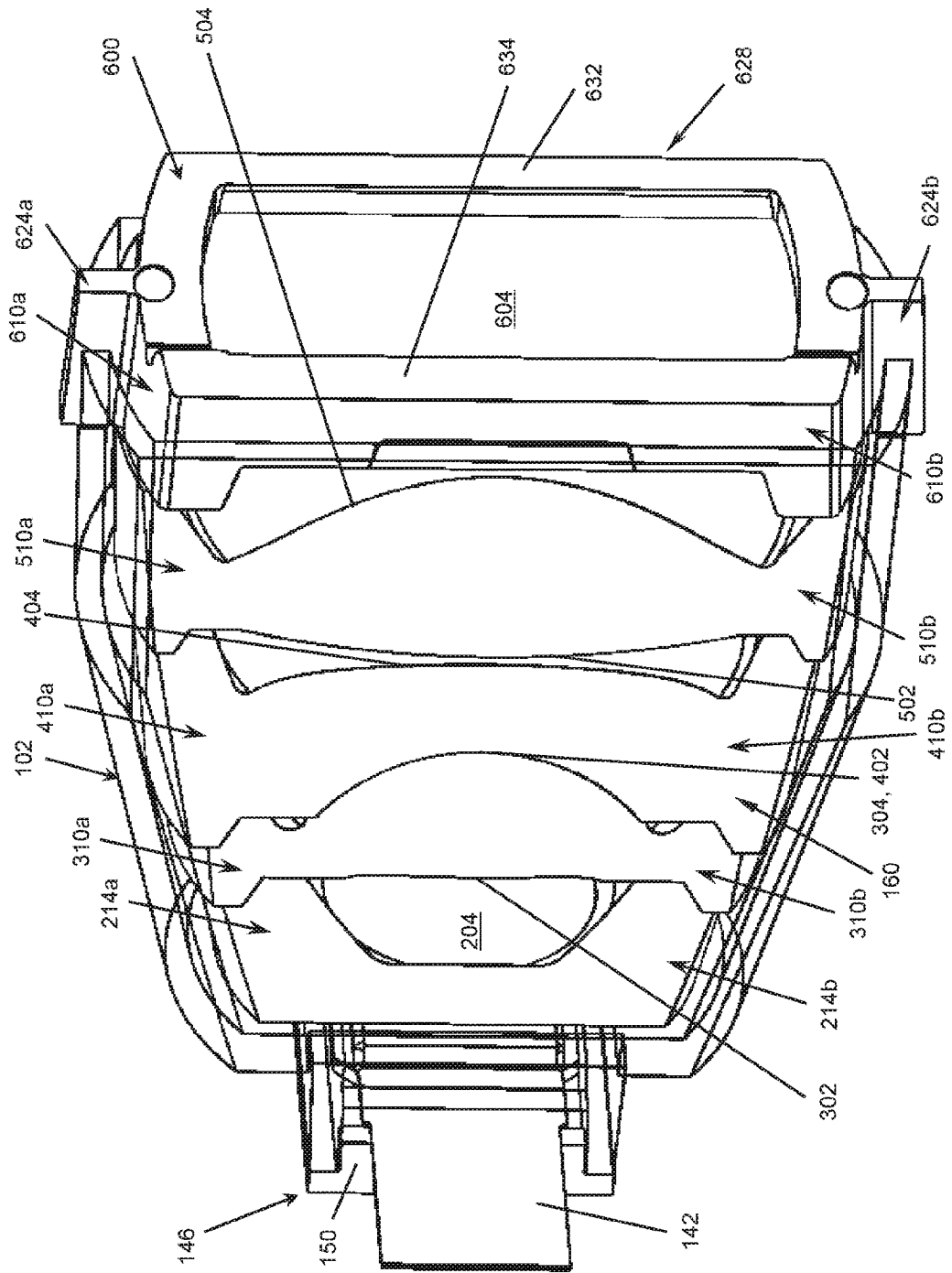

FIG. 6

6/27

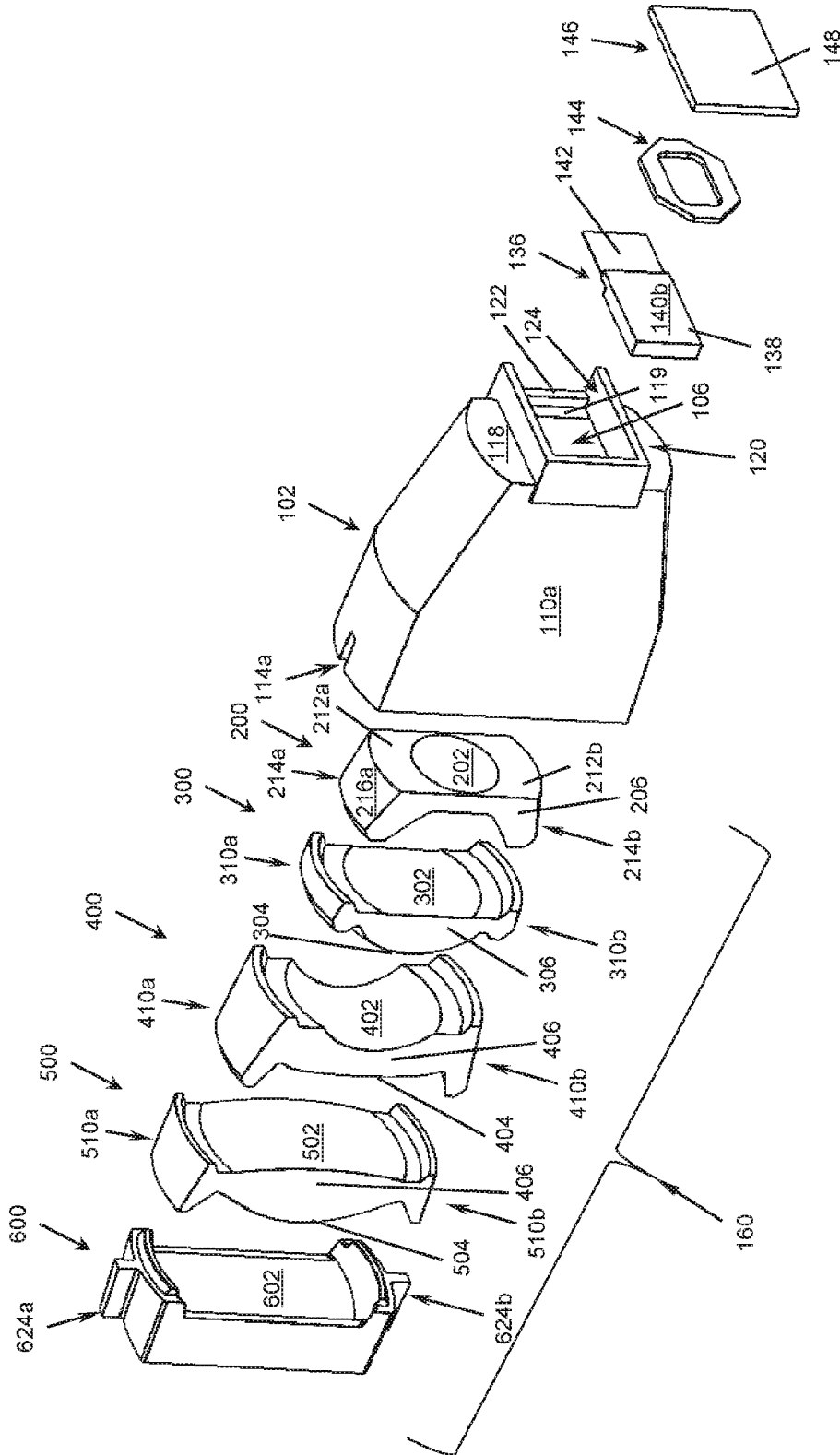

FIG. 7

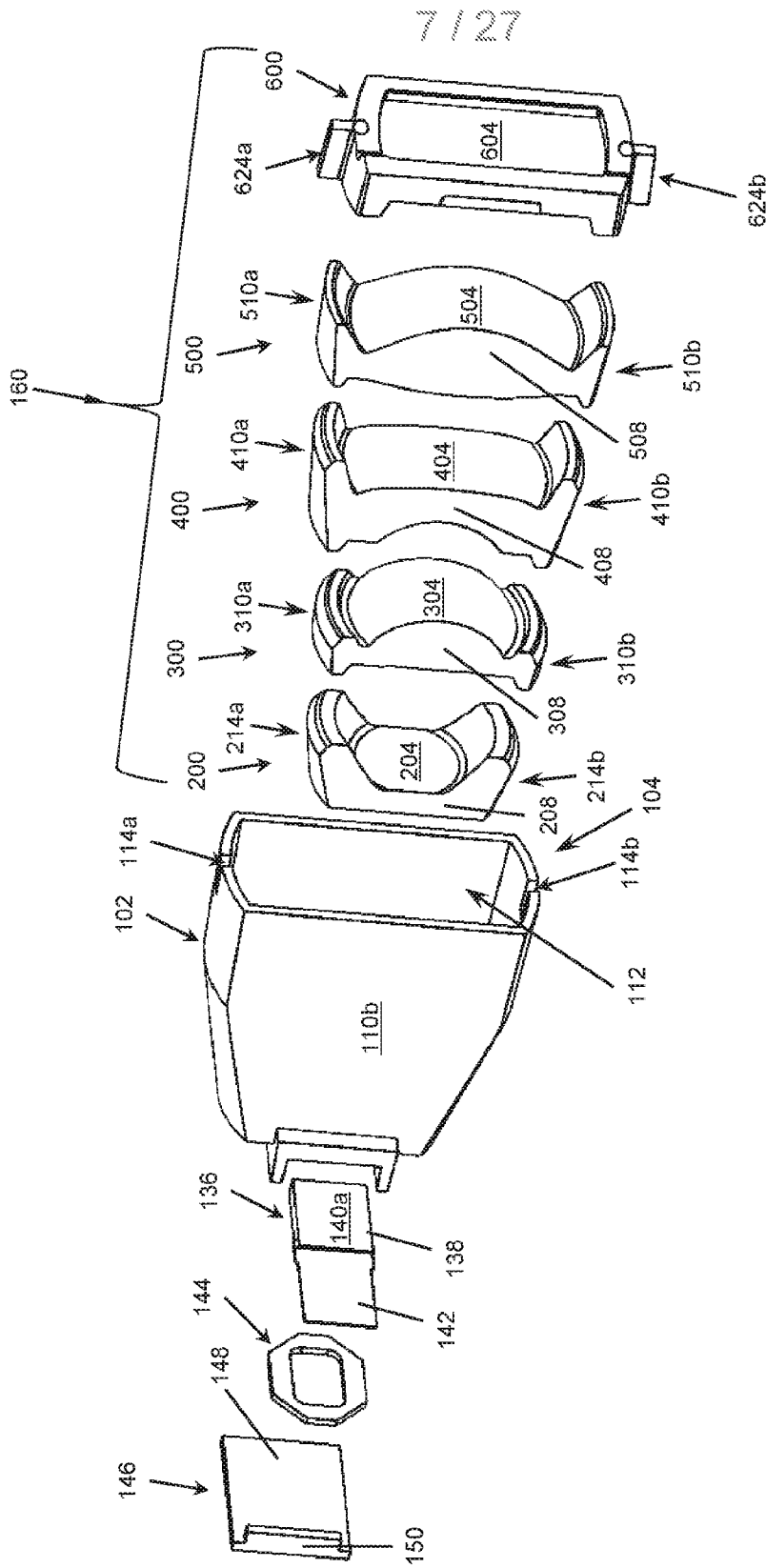

FIG. 8

8/27

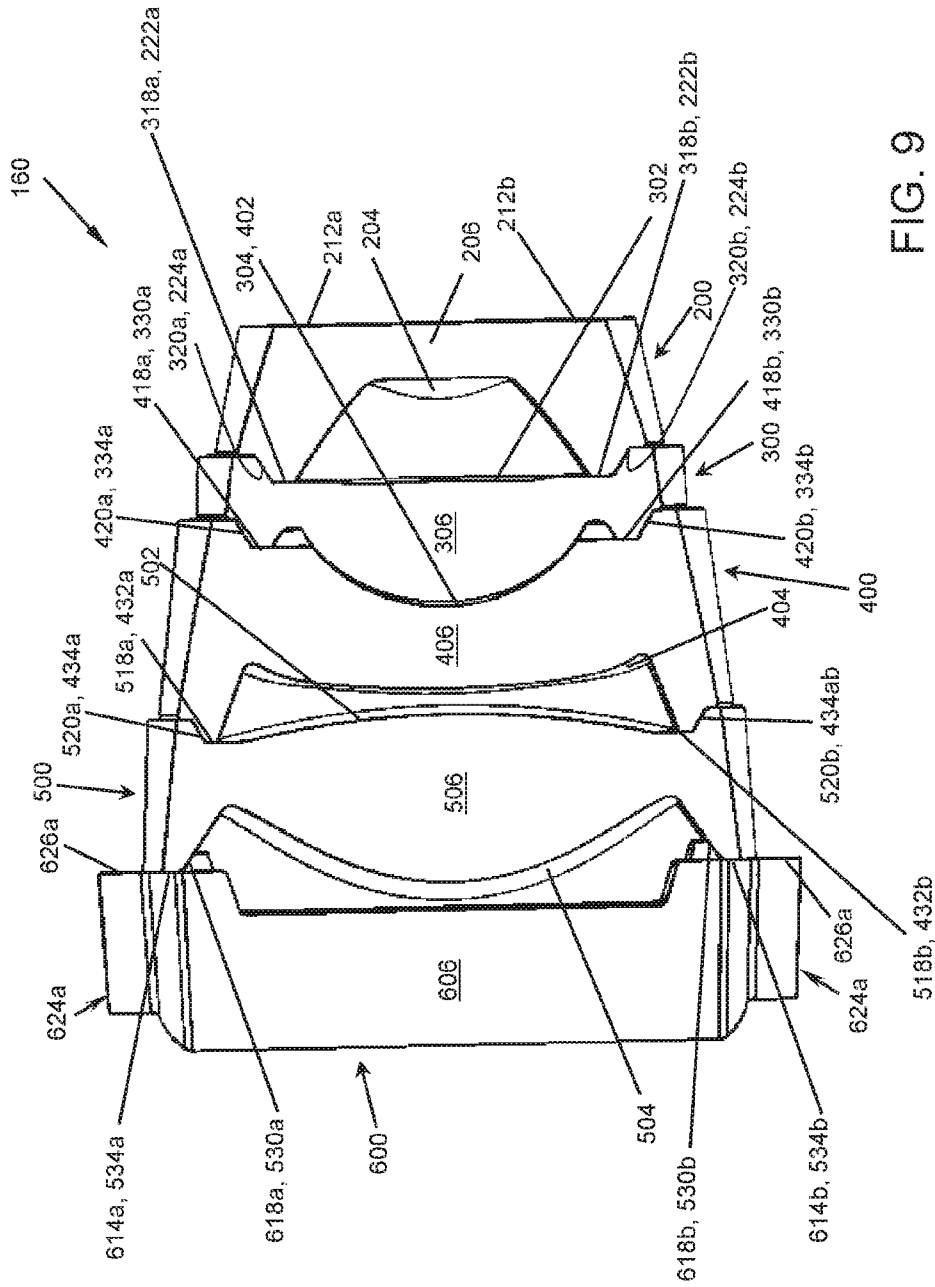

FIG. 9

9/27

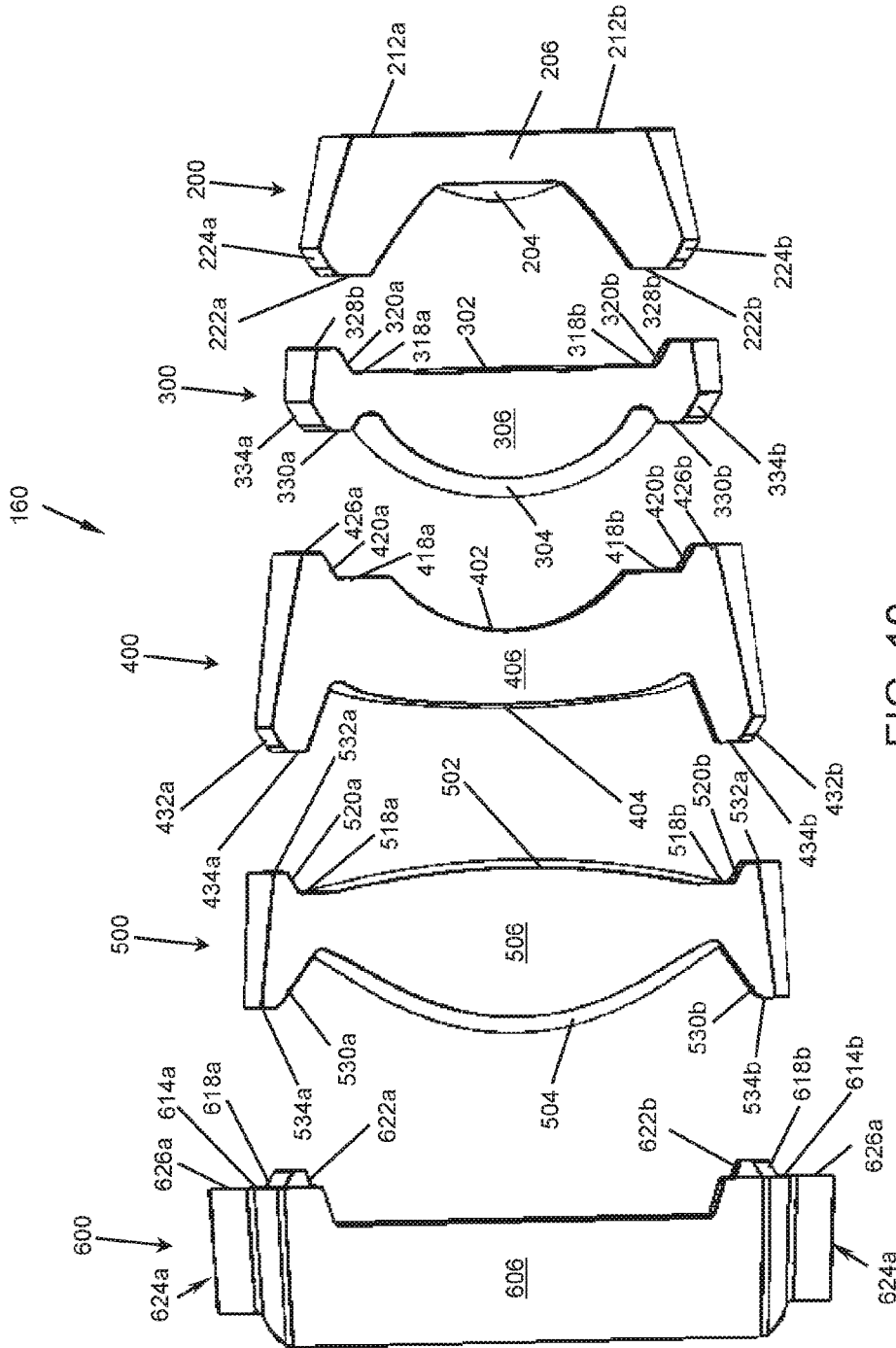

FIG. 10

10/27

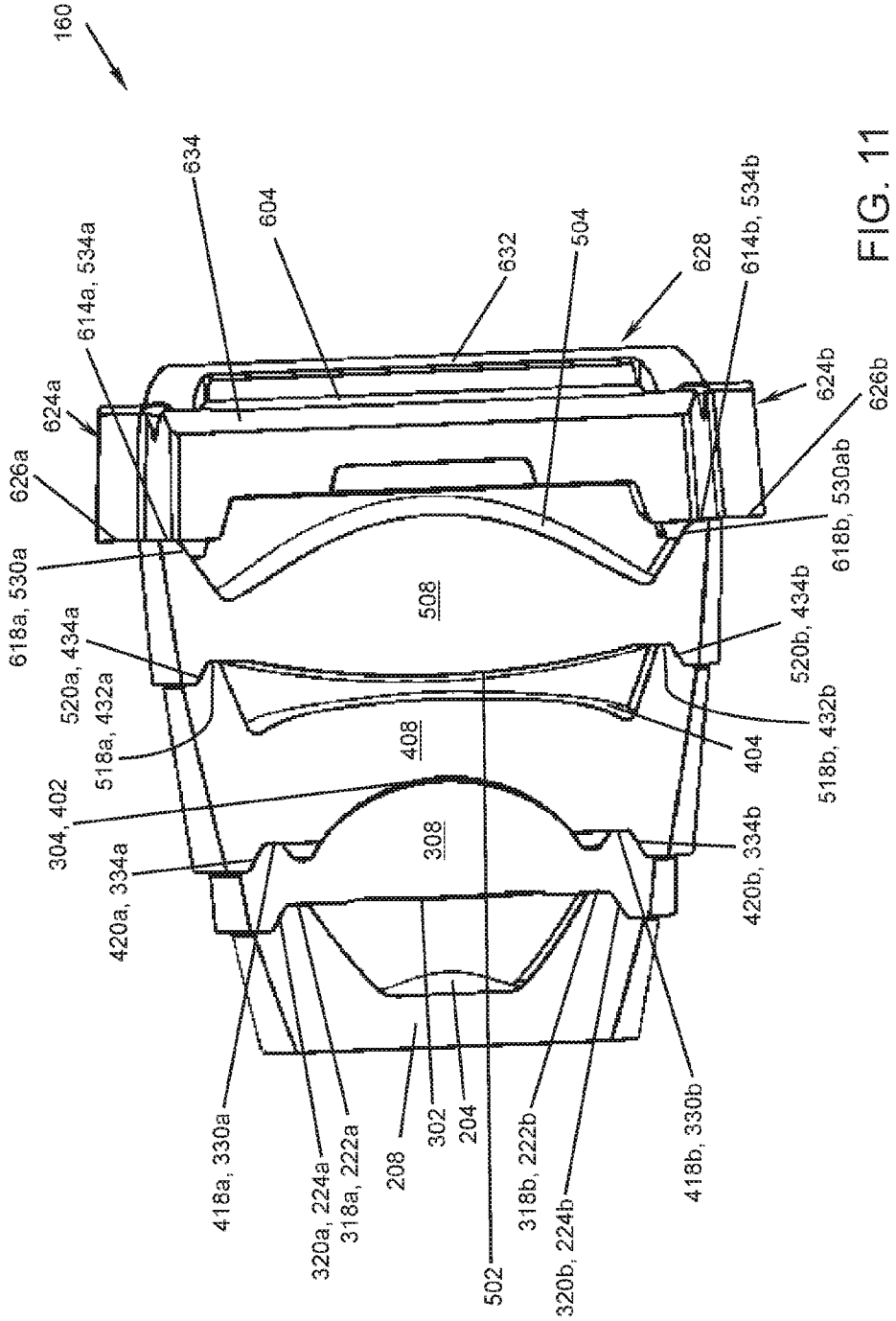

FIG. 11

11/27

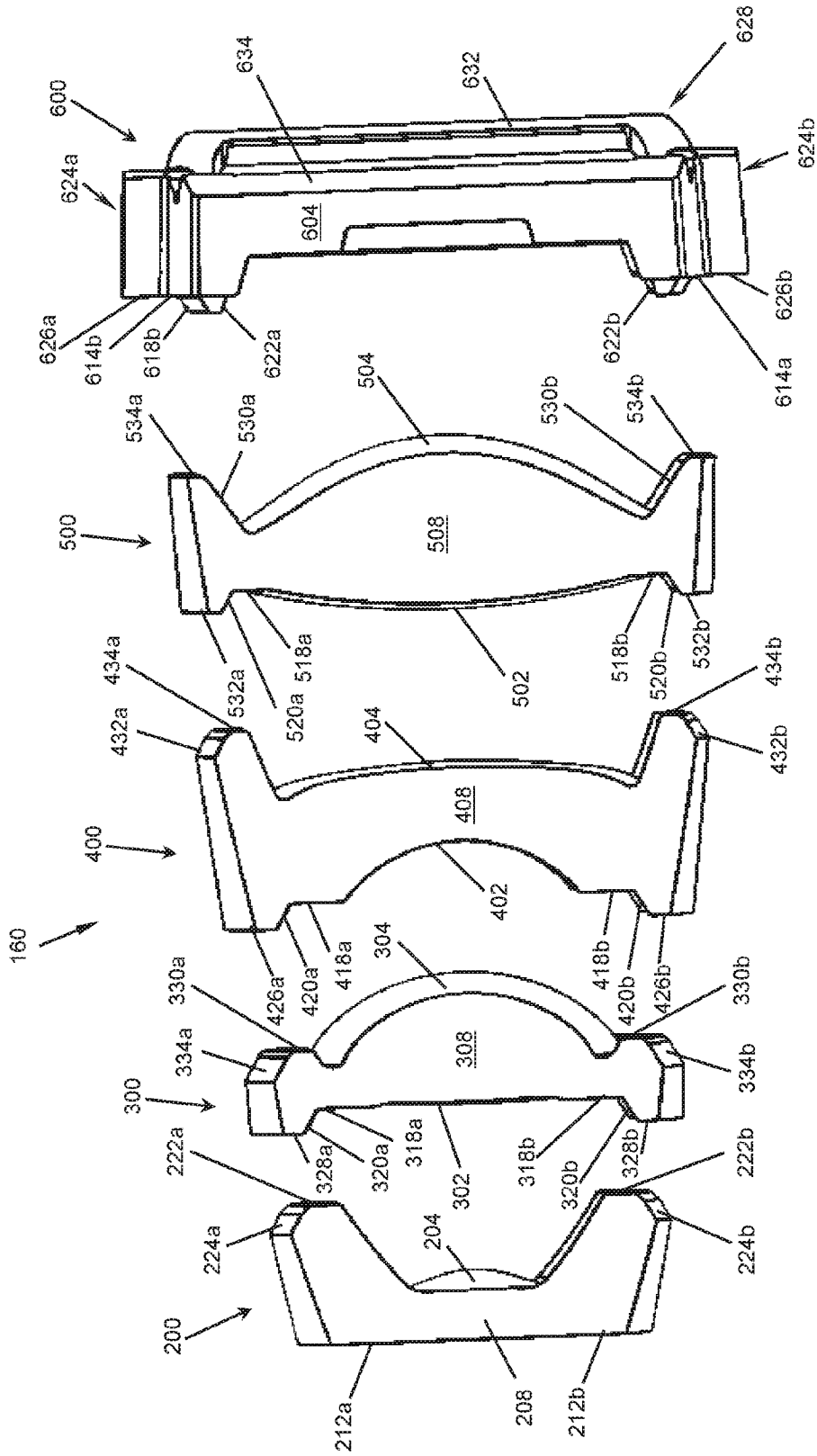

FIG. 12

12 / 27

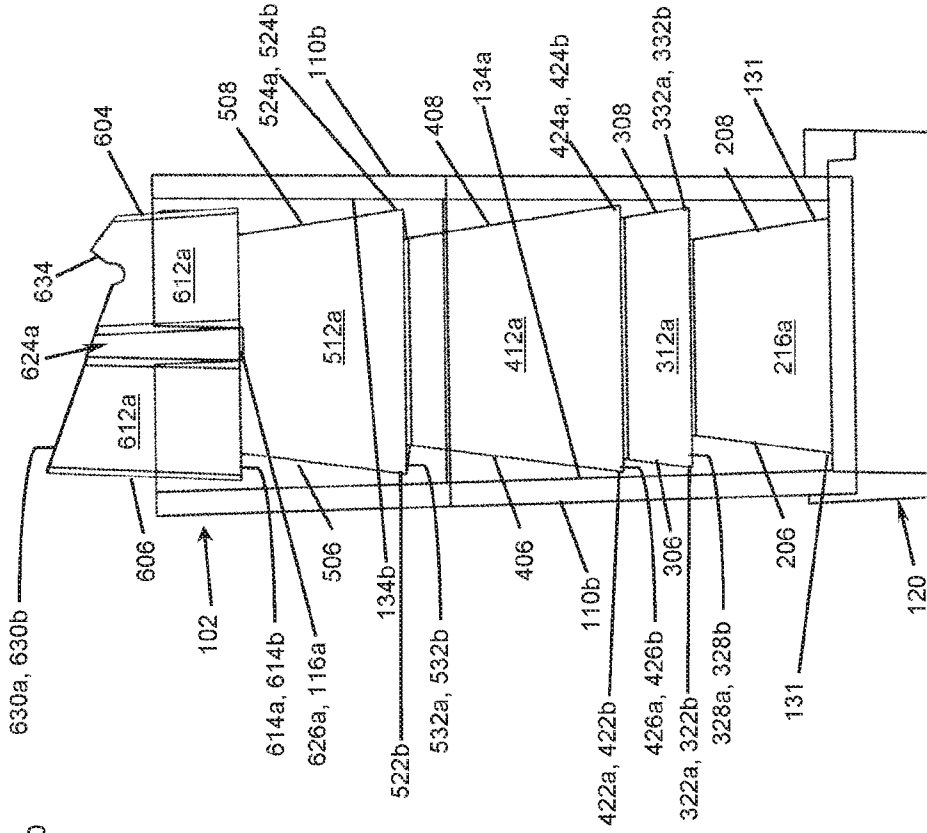

FIG. 14

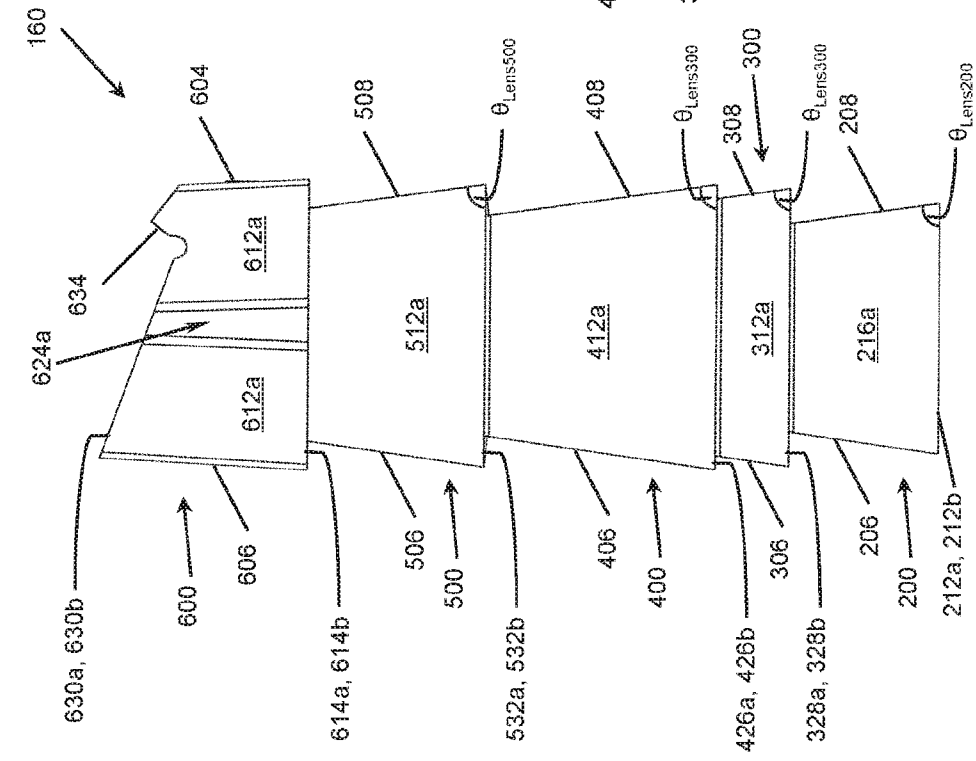

FIG. 13

13/27

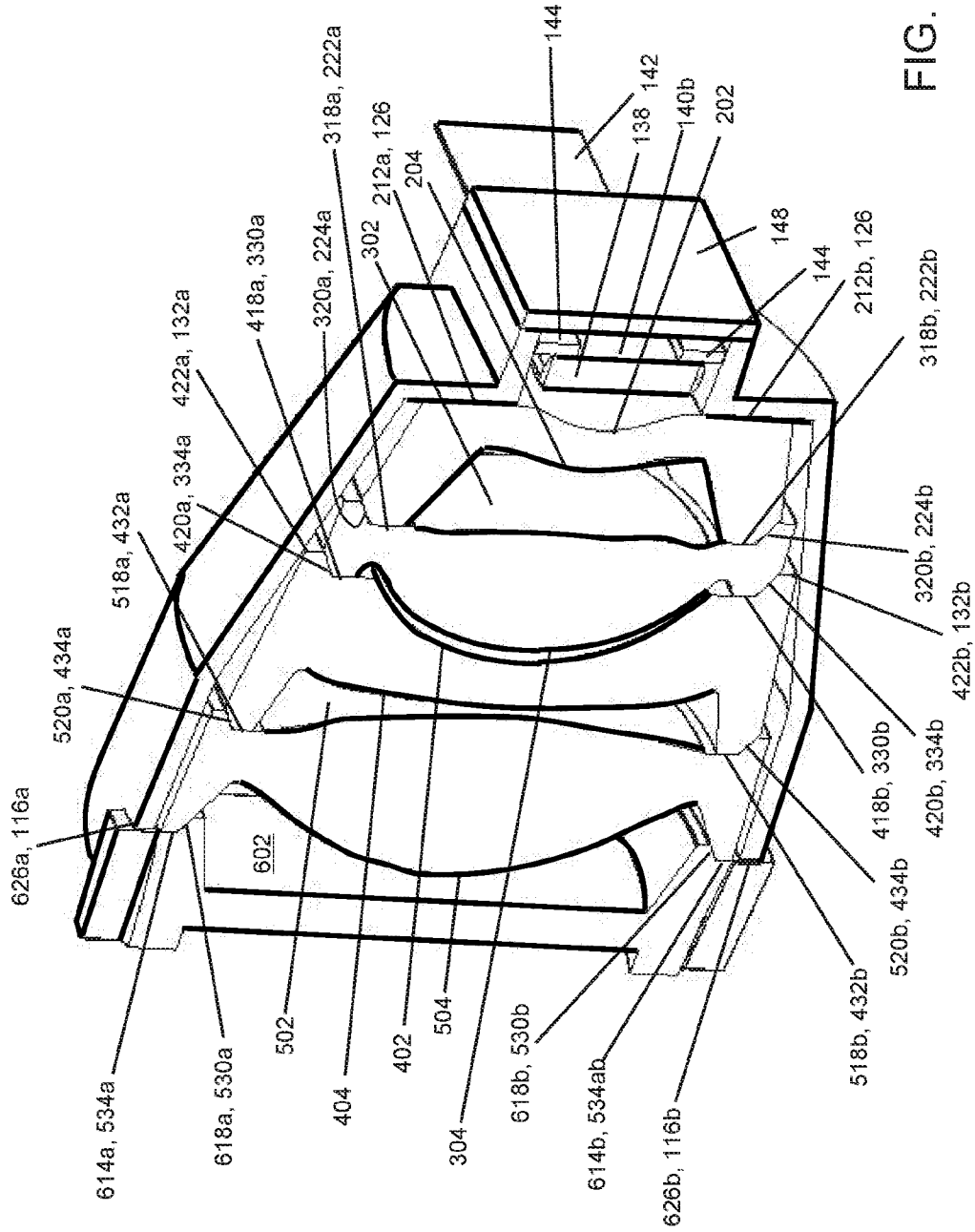

FIG. 15

14/27

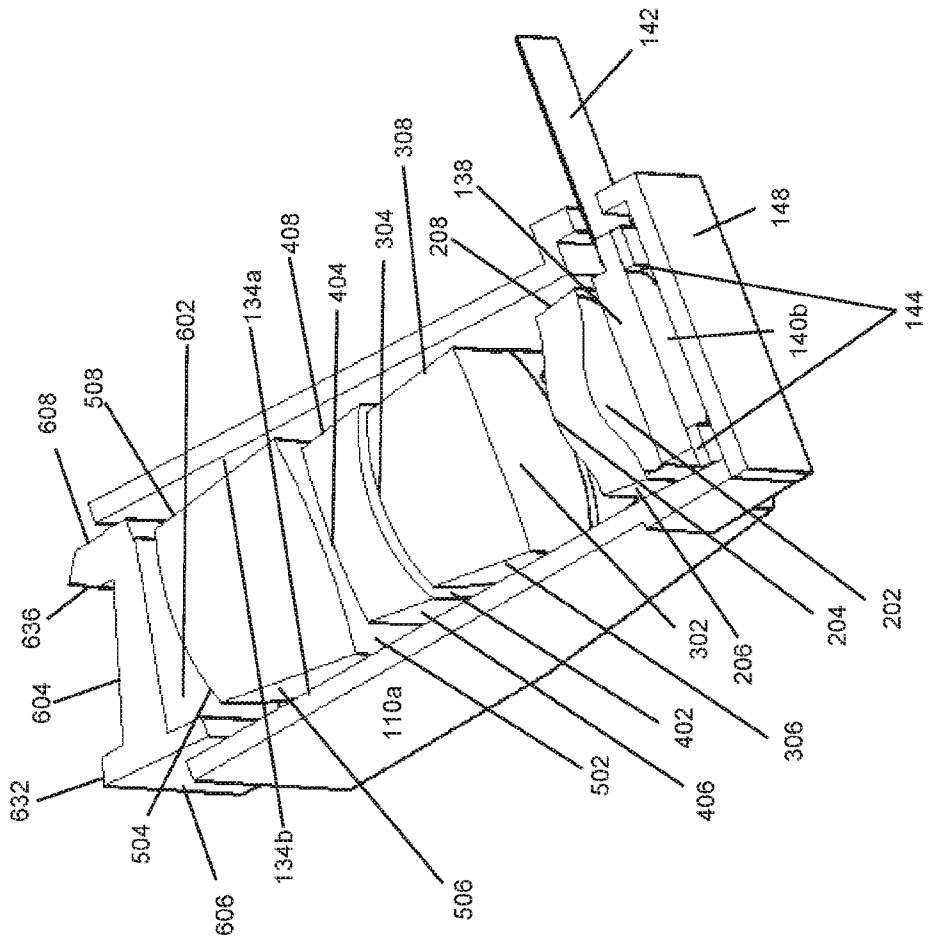

FIG. 16

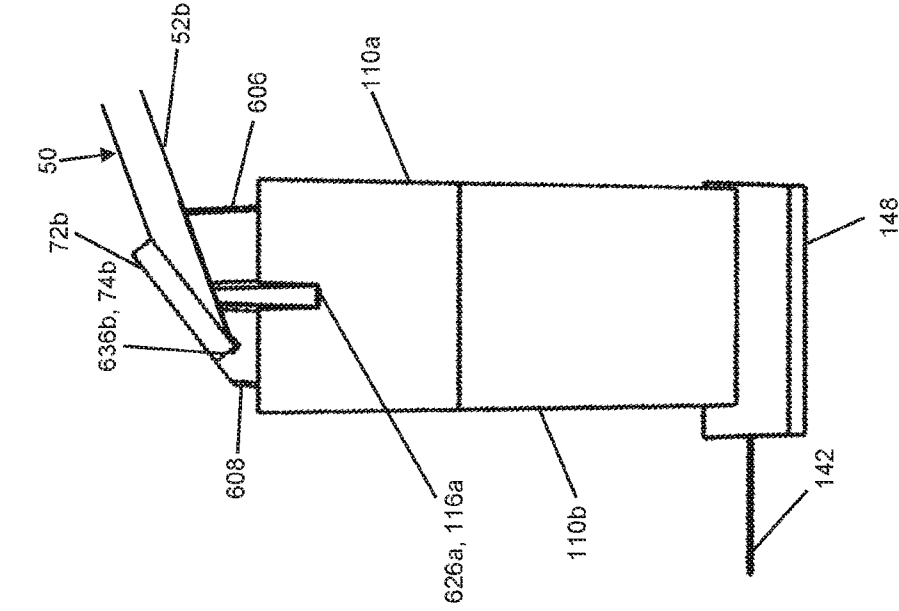

FIG. 17

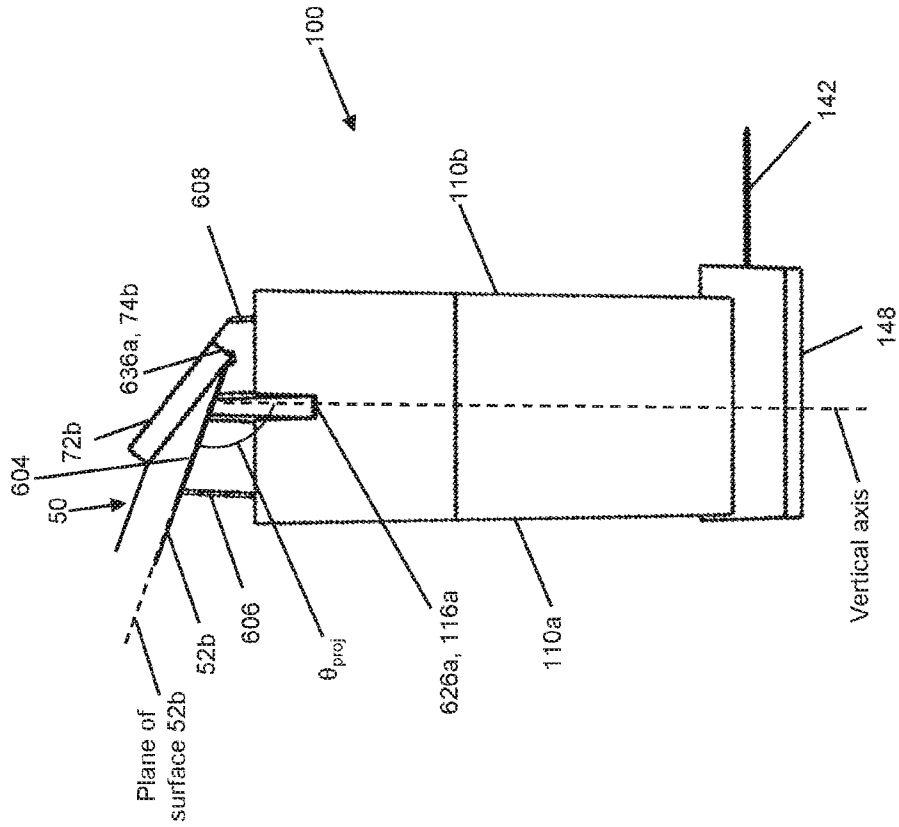

FIG. 18

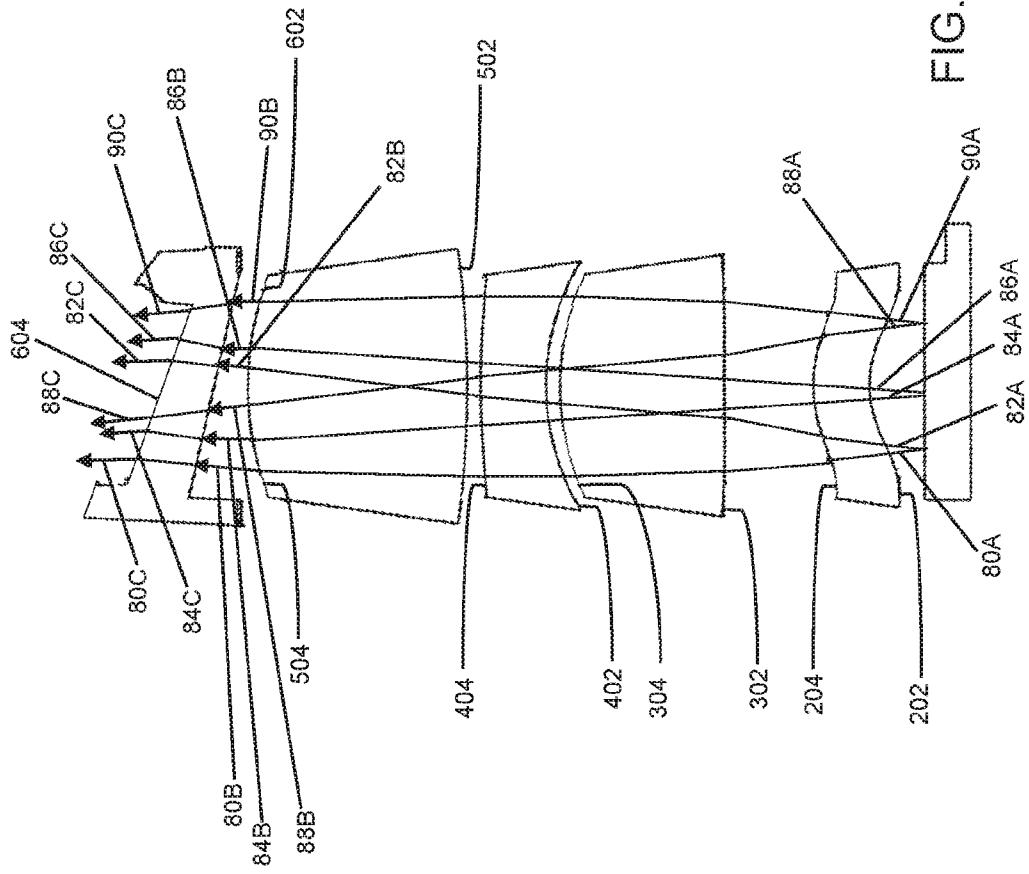

FIG. 19

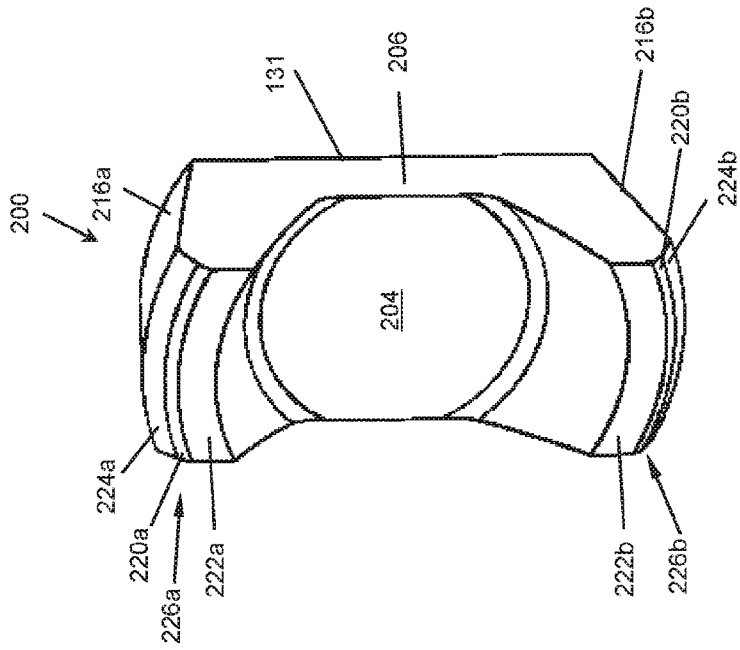

FIG. 21

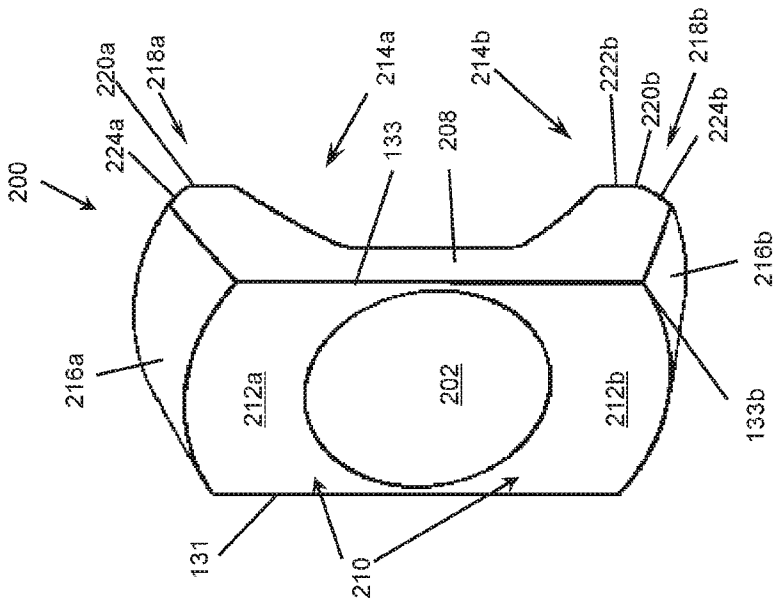

FIG. 20

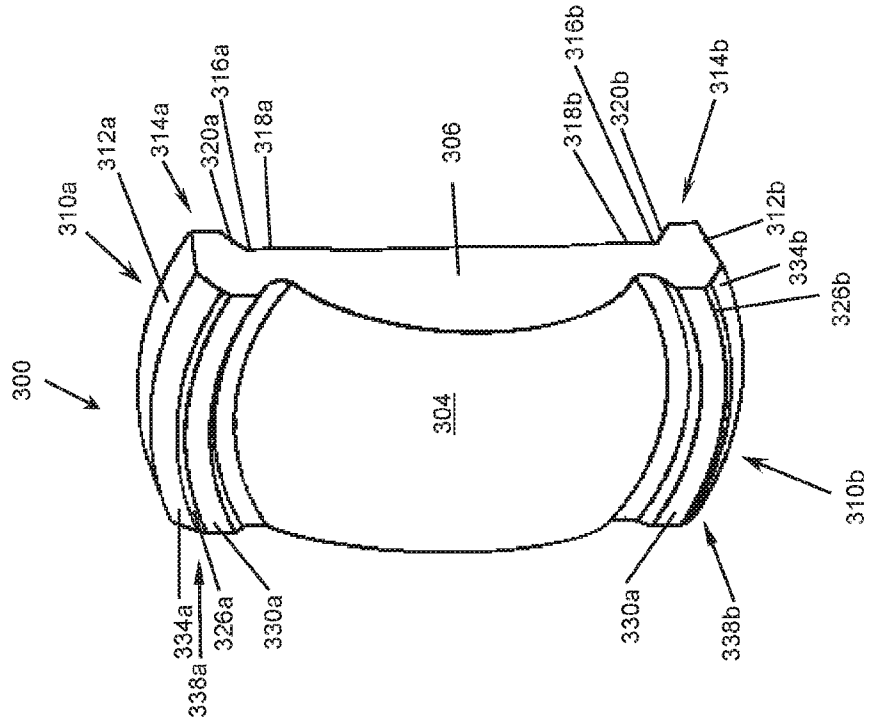

FIG. 23

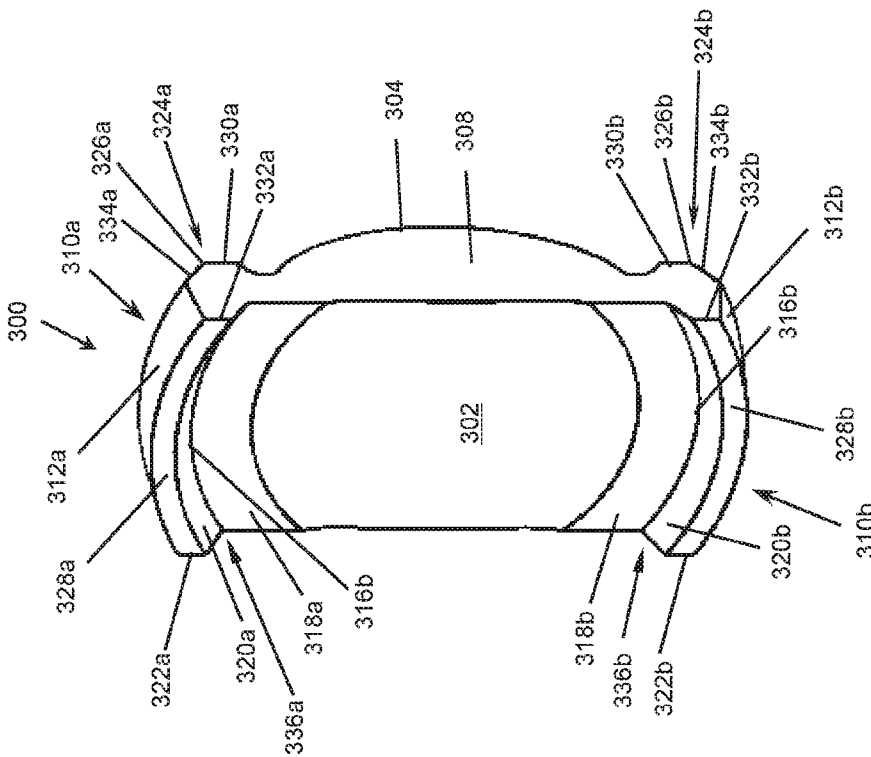

FIG. 22

10/27

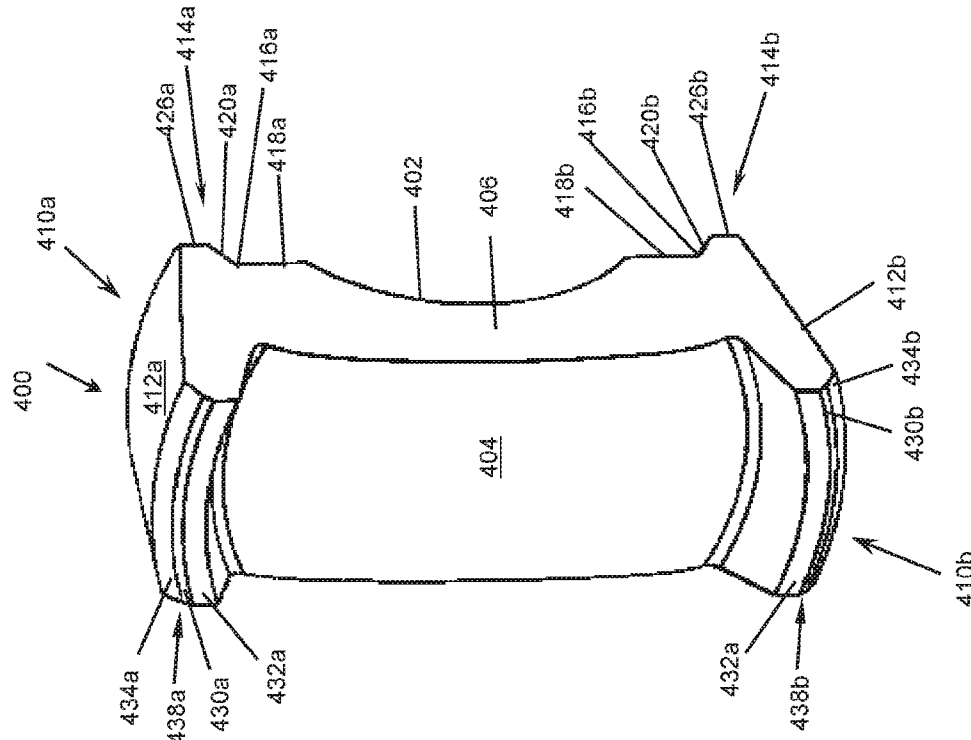

FIG. 25

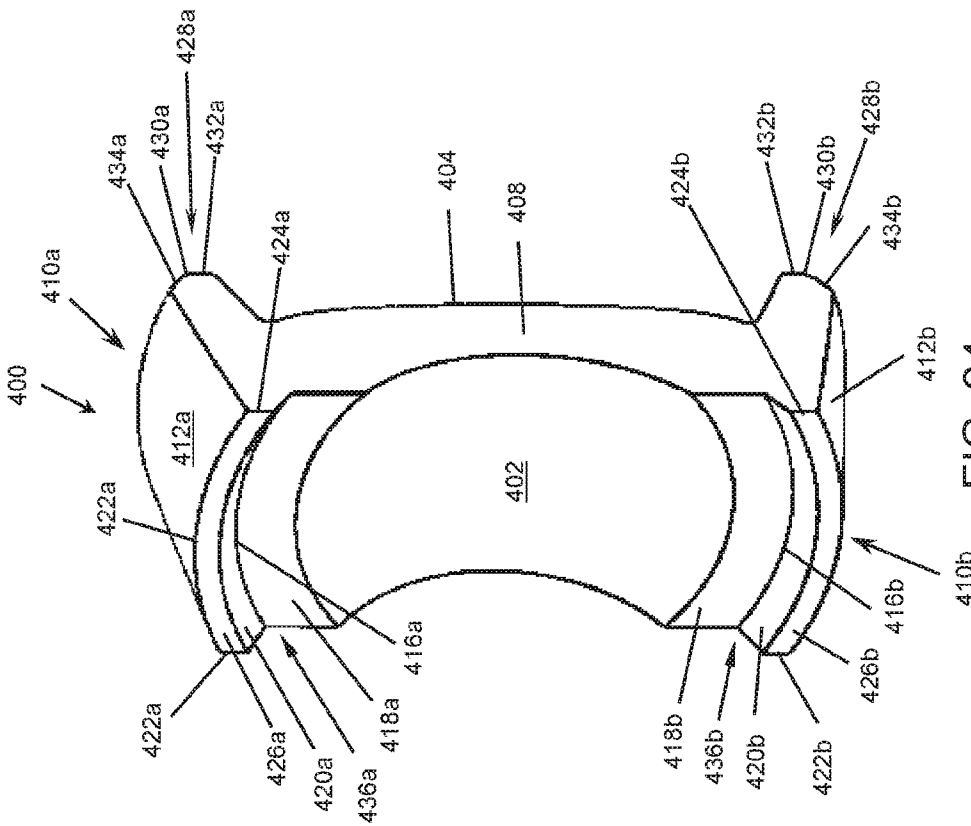

FIG. 24

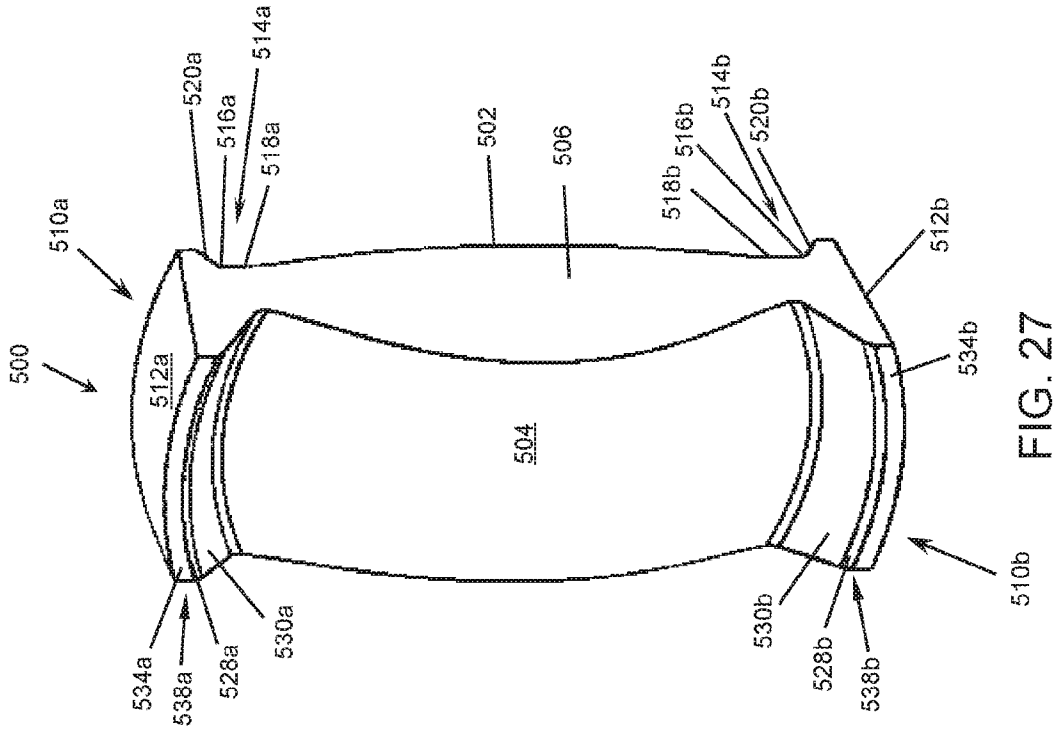

FIG. 27

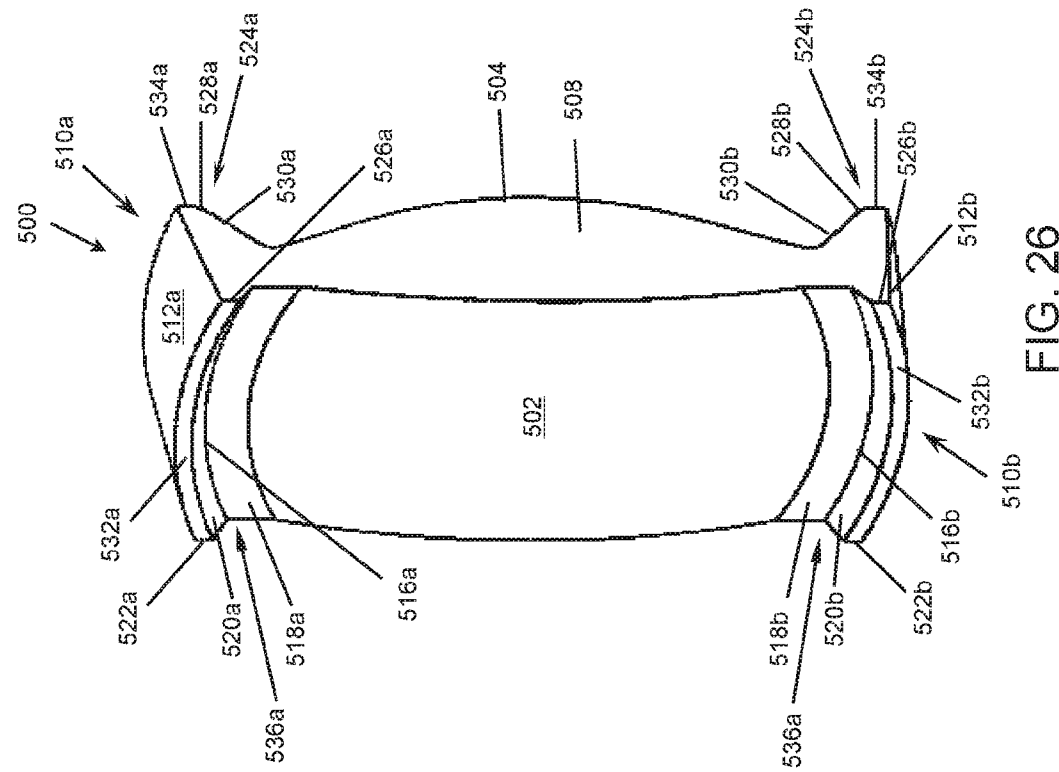

FIG. 26

21 / 27

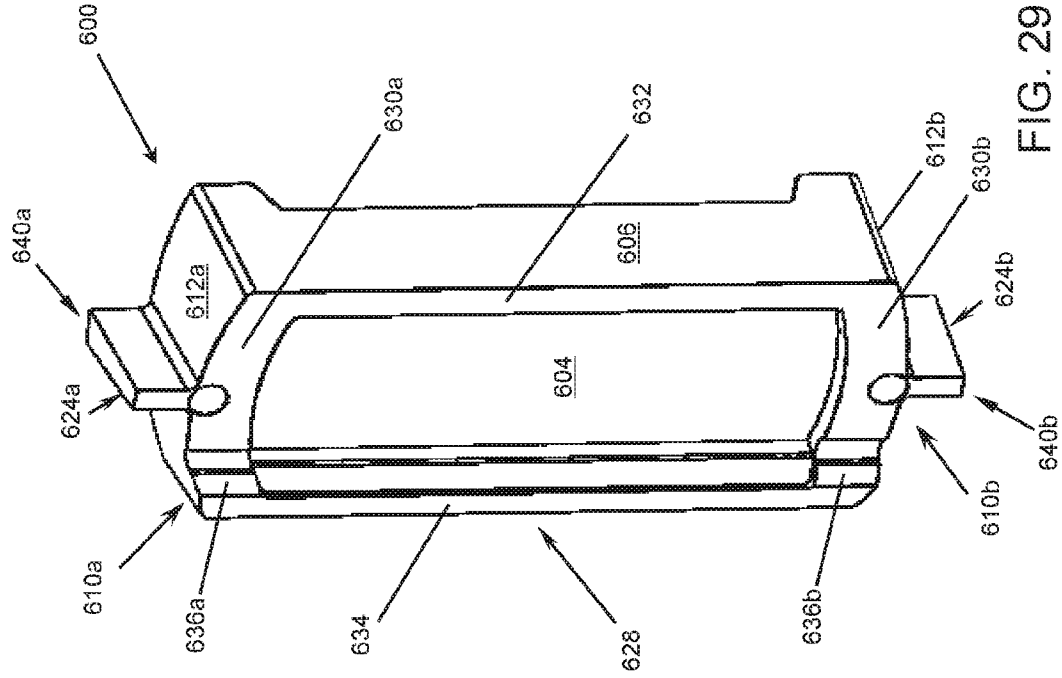

FIG. 29

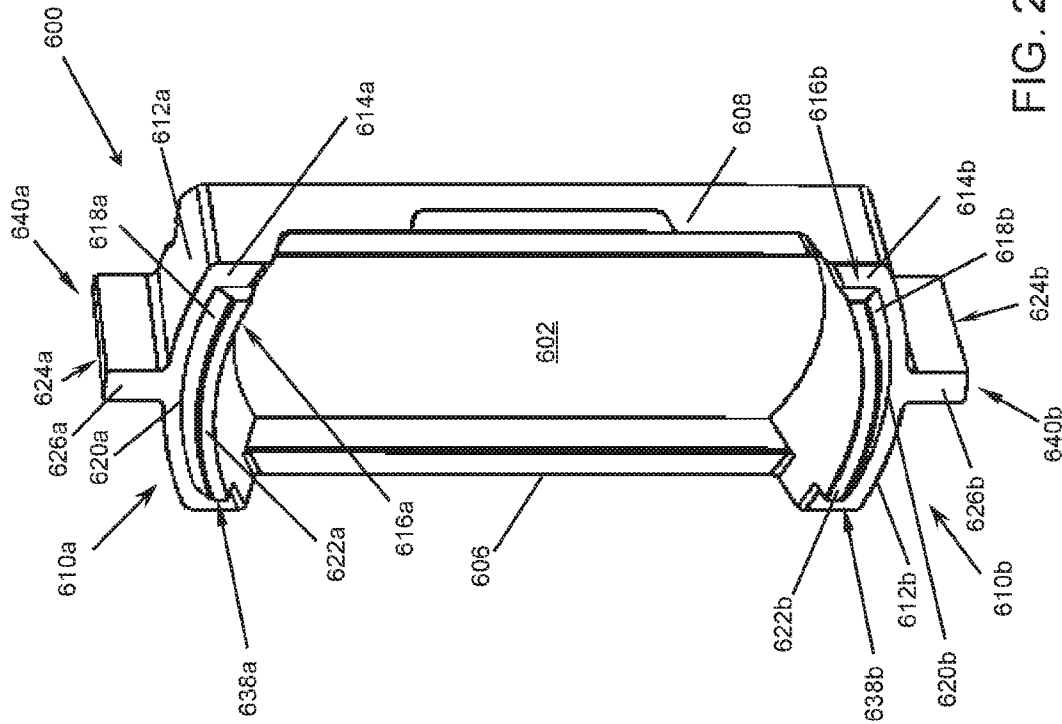

FIG. 28

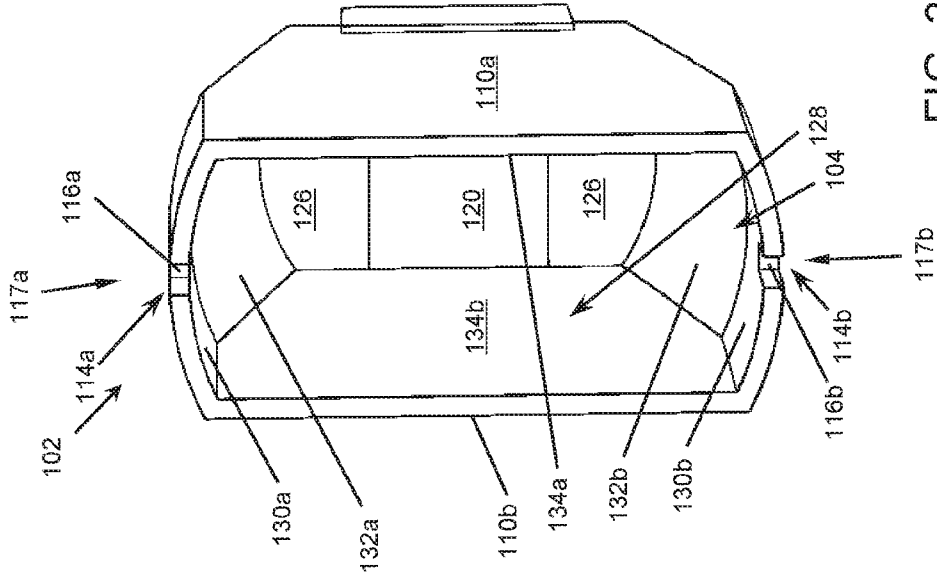

FIG. 31

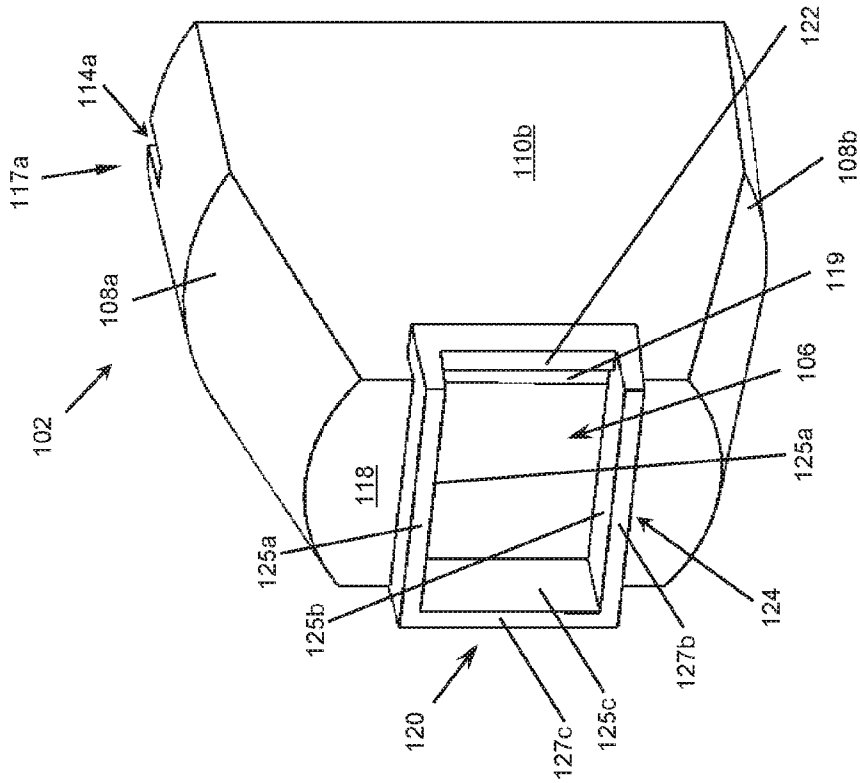

FIG. 30

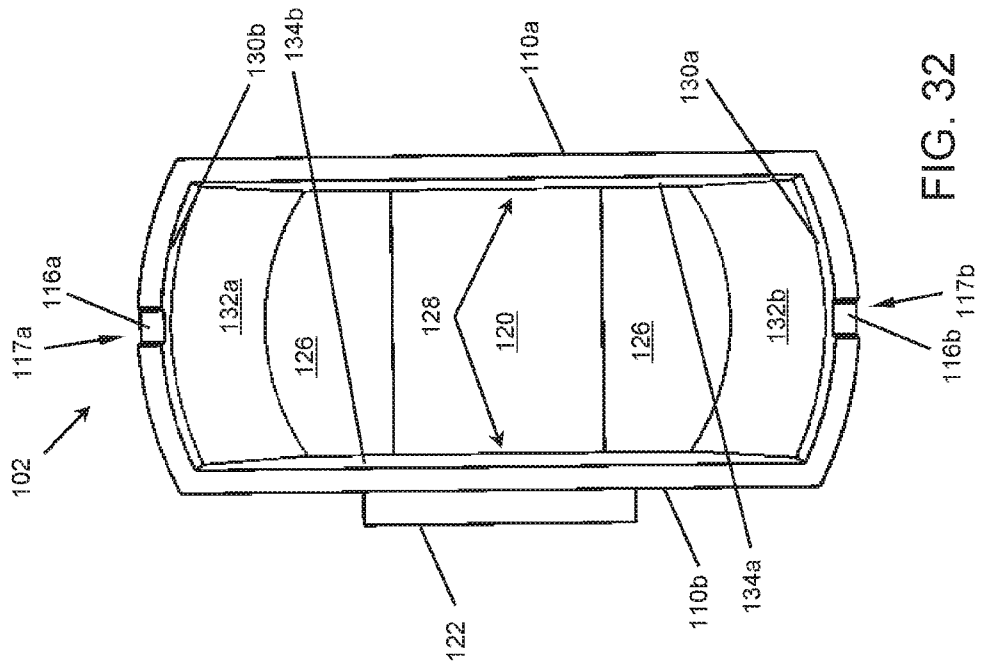

FIG. 32



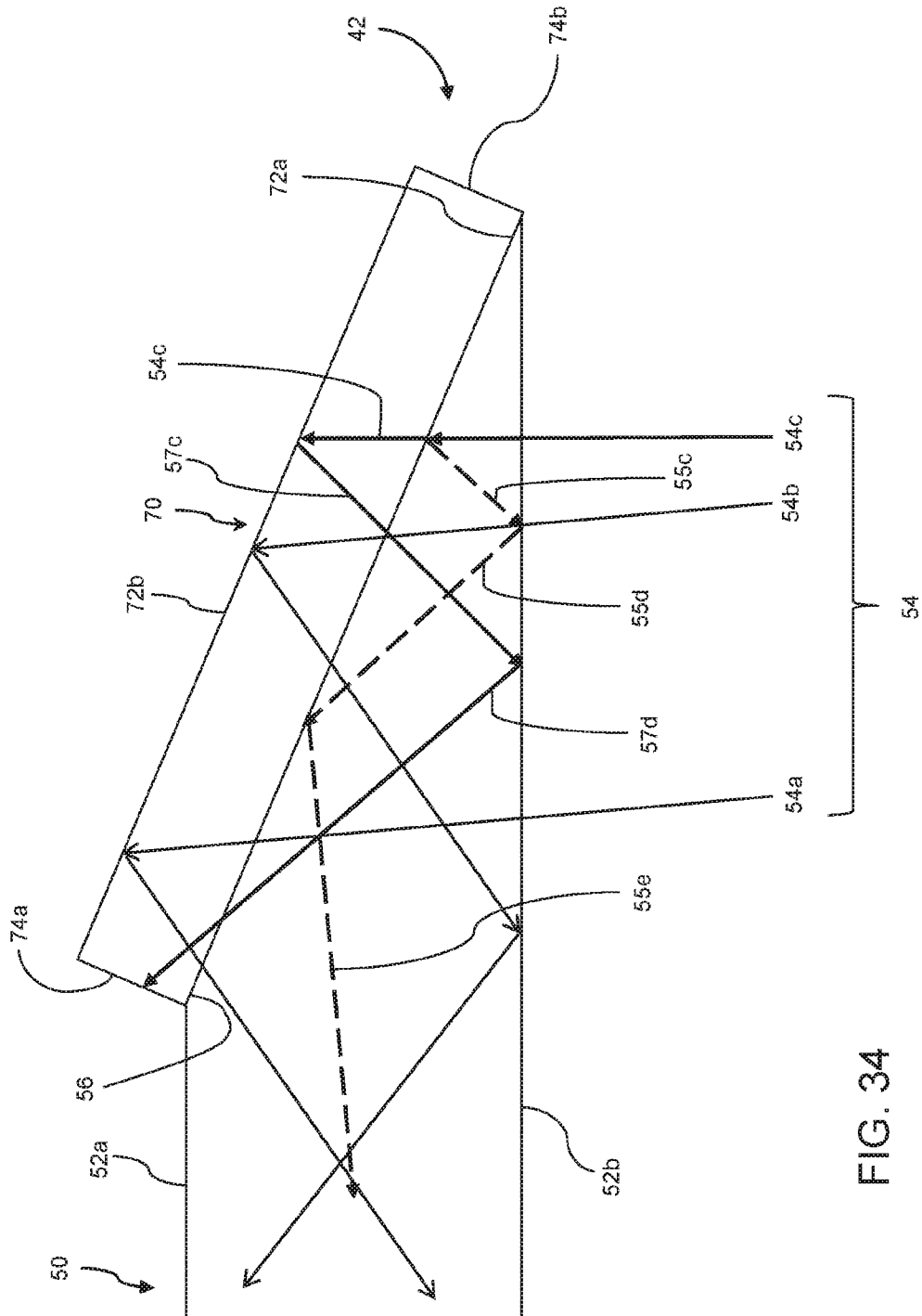

FIG. 34

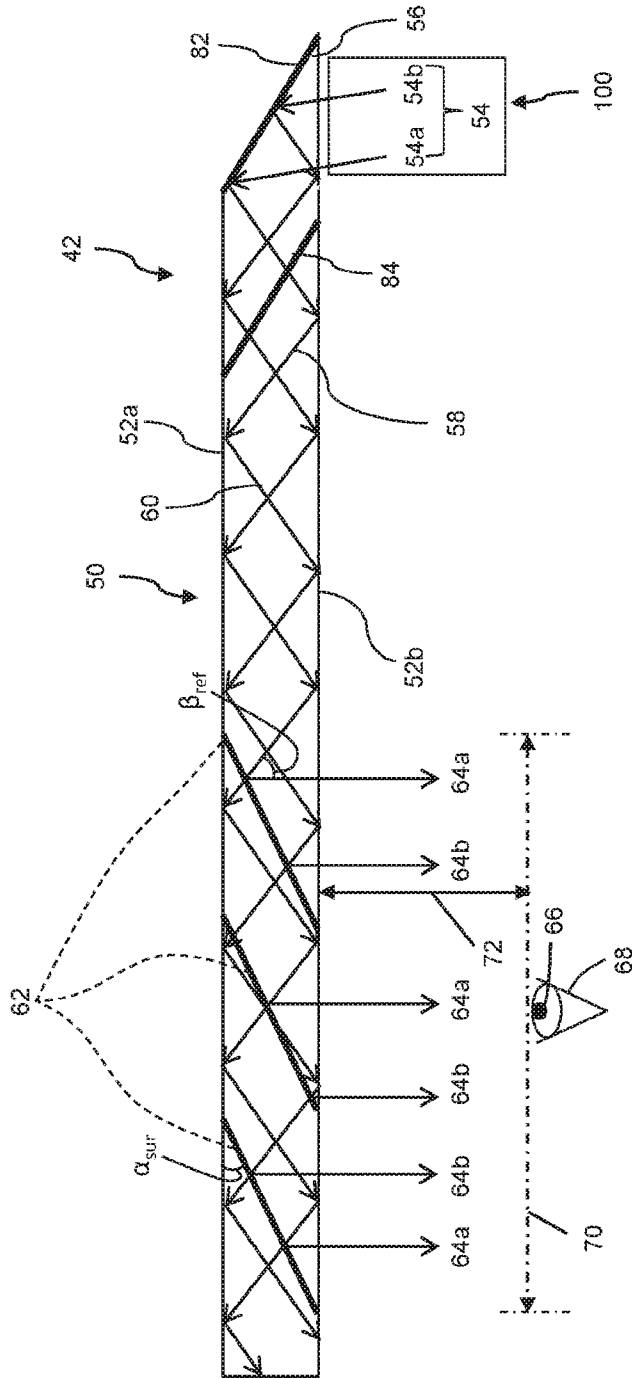

FIG. 35

27 / 27

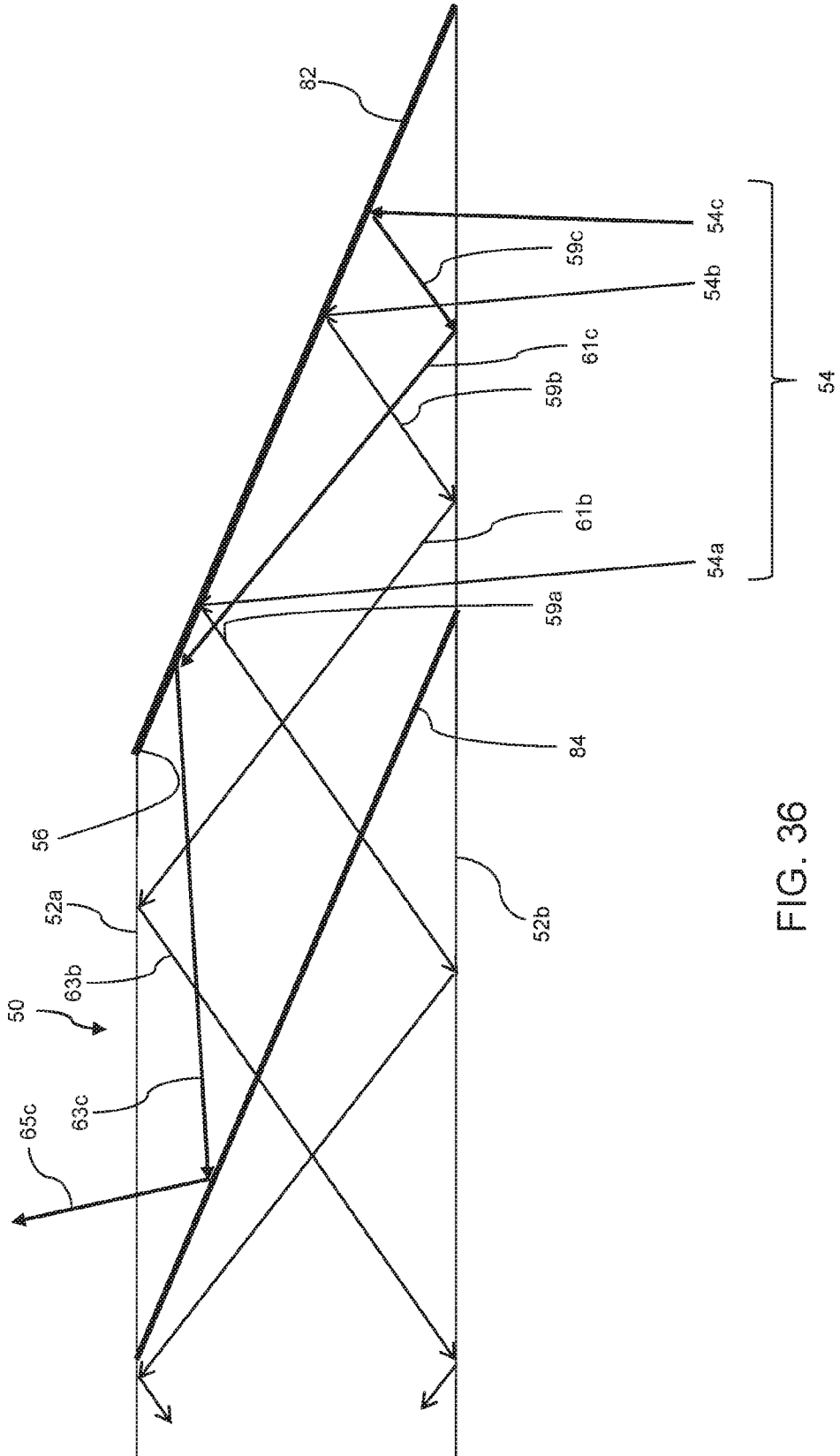

FIG. 36

