

F. O. BLACKWELL.
CONTROLLING DEVICE FOR ELECTRIC MOTORS.

No. 452,423.

Patented May 19, 1891.

Fig-1.

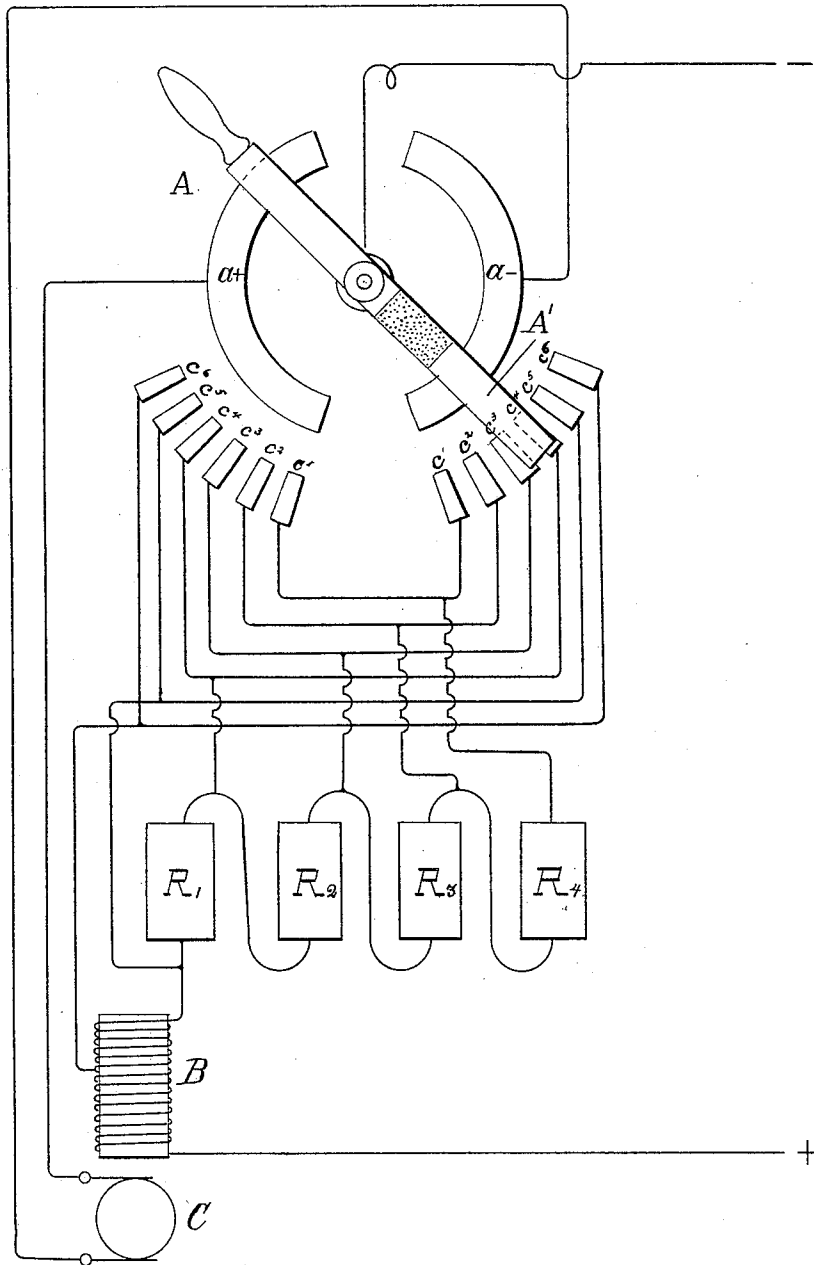

Witnesses

Jos. E. Allen
G. P. Maul

Inventor

Francis O. Blackwell
by Britten & Wright
Atty.

F. O. BLACKWELL.
CONTROLLING DEVICE FOR ELECTRIC MOTORS.

No. 452,423.

Patented May 19, 1891.

Fig. II.

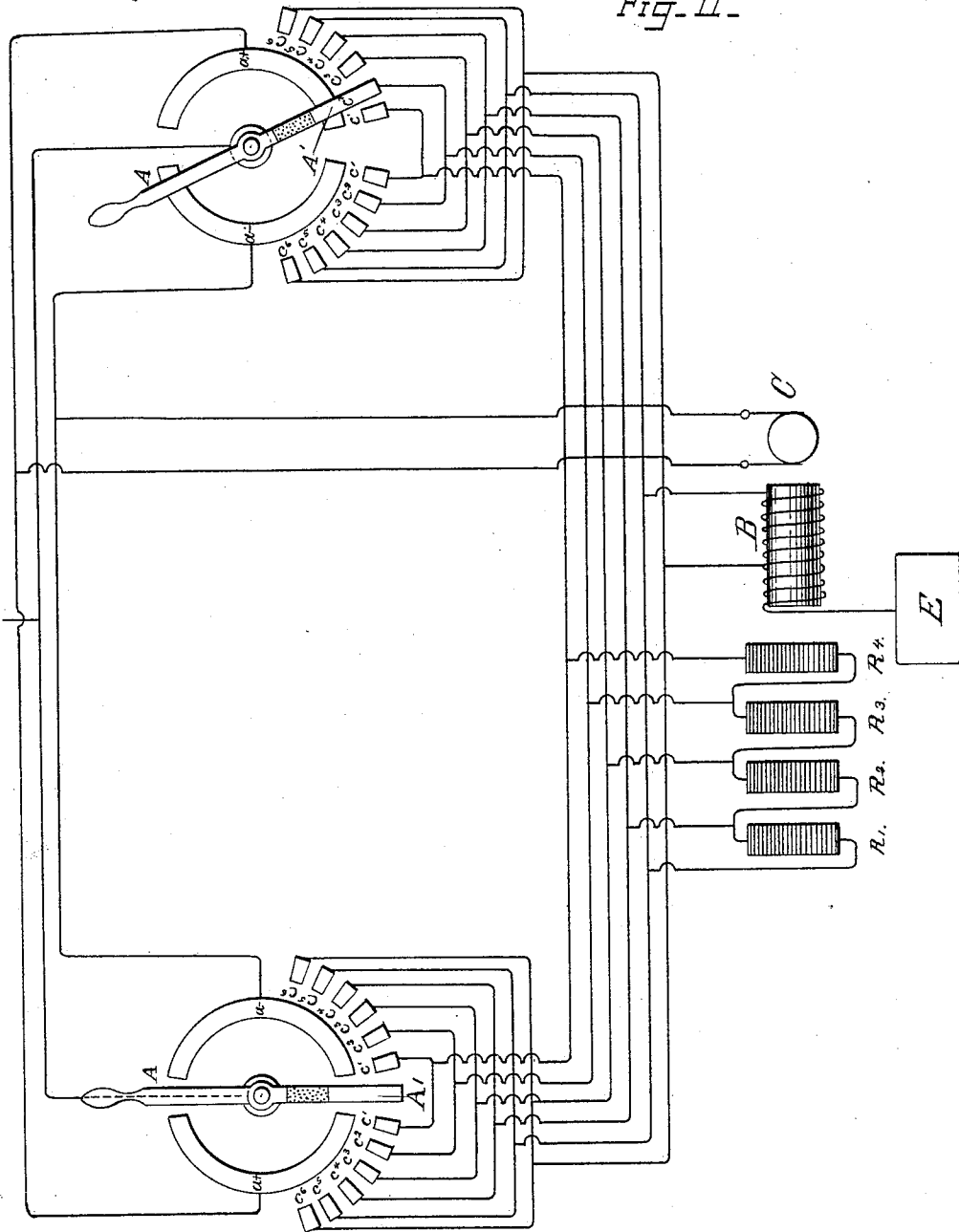

Witnesses

Joseph E. Aue
G. Prunault

Inventor

Francis O. Blackwell
by *Buttley & Knight*
Attys.

UNITED STATES PATENT OFFICE.

FRANCIS O. BLACKWELL, OF NEW YORK, N. Y., ASSIGNOR TO THE THOMSON-HOUSTON ELECTRIC COMPANY, OF CONNECTICUT.

CONTROLLING DEVICE FOR ELECTRIC MOTORS.

SPECIFICATION forming part of Letters Patent No. 452,423, dated May 19, 1891.

Application filed July 13, 1889. Serial No. 317,376. (No model.)

To all whom it may concern:

Be it known that I, FRANCIS O. BLACKWELL, a citizen of the United States, residing at New York, in the county of New York and State of New York, have invented certain new and useful Improvements in Controlling Devices for Electric Motors, of which the following is a specification.

My invention relates to controlling devices for electric motors, especially those used for propelling electric-railway vehicles.

It consists in a switch device which has a movement in either direction from a neutral or central position, and which when moved in one direction acts to throw the reverse-switch and then cut out more or less of a resistance to control the action of the motor, and when moved in the opposite direction acts to throw the reverse-switch to the opposite position and then cut out the resistance in the same manner. This switch I duplicate at opposite ends of a car.

In the accompanying drawings, Figure I is a diagram of my switch. Fig. II is a diagram of a double switch at opposite ends of a car.

In the drawings, A A' is a combined regulating and reversing switch, pivoted as shown. Its two parts A A', which are insulated from each other, form in effect a reversing-switch and a regulating-switch, which are connected and operated together. Two segmental plates a^x and a are arranged about the center of A, which comes in contact with them as it is moved from one side to the other of a central position and maintains contact during a considerable range of movement, whereby after being thrown to start the motor in a given direction of rotation further movement of the switch is possible to effect the desired current-regulation. The segments a^x are connected, respectively, to the opposite terminals of one component part of the motor, the armature being the one shown, and A is connected directly to line.

Concentric with A and with a^+ and a^- are a series of contacts c c' c^2 , &c., connected to successive points of a resistance R' R², &c. Two duplicate sets of these contacts are provided, corresponding to a^+ and a^- , respectively, so that regulation of the motor can be

effected in the same manner no matter which way the reversing-switch is thrown. The last of these contacts c^6 in each set is connected to an intermediate point in the field-magnet coil, and each contact in one set is connected to the corresponding contact in the other set. B is the field-magnet of the motor, and C is the armature.

In the position shown in Fig. I the circuit is as follows: +, B, R', R², c^3 , A', a^- , C, a^+ , A⁻, and half speed is given to the motor. As A is moved farther R' and R² are cut out, and when A' reaches c^6 a section of magnet B is also cut out and an extra speed given to the motor. When A is in a vertical position the circuit is entirely broken, and when moved to the right the same result is given except that the direction of current in armature C is reversed and the motor proceeds in the opposite direction.

When, as in Fig. 2, it is necessary to operate the vehicle from either end, the resistance R' R², &c., is placed at an intermediate point of the vehicle and a set of nine wires are led from one end of the car to the other. Of these six are connected to successive points of the resistance and terminate at each end in duplicate sets of contact points c' c^2 , &c. Of the remaining three one goes to line and to the two levers A, while the other two connect the armature terminals with the two sets of segments a^+ and a^- . One end of field B is connected to the opposite line terminal. In this way the motor is controlled and reversed by separate switches at each end of the car, each of which effects the regulation and reversal, as desired, by movement of a single lever or other operating handle.

What I claim as new, and desire to secure by Letters Patent, is—

1. The combination, in an electrically-propelled vehicle, of a resistance located at an intermediate point thereof, two series of connections extending therefrom to separate points of the vehicle, respectively, and there terminating in duplicate sets of contact-pieces, and a contact-arm connected to reversing devices and acting on the duplicate sets of contact-pieces, respectively, in corre-

spondence to opposite positions of the reversing devices.

2. The combination, with an electric motor, of contact-plates connected, respectively, with the terminals of one of the component parts of the motor, a reversing-switch connected directly to line and thrown from one to another of said contact-plates to reverse the motor, and a variable resistance controlled by said switch.

3. The combination, with an electric motor, of the contact-plates $a a^x$, connected to the terminals of one component part of the motor, a resistance provided with a double set of contacts, a reversing-switch connected to line and movable into contact with one or another of said contact-plates at will to reverse the motor, and means controlled by the reversing-switch for varying the resistance of the motor-circuit, while the flow of current through it is in either direction as determined by the said switch.

4. The combination, in an electrically-propelled vehicle, of a reversing-switch, a variable resistance controlled thereby, and a circuit-charger for the field-magnet coil, also controlled by said switch.

5. The combination, in a controlling-switch for an electric motor, of contact-pieces a^+ and a^- , connected, respectively, to the opposite terminals of one of the component parts of the motor, a contact-arm A, connected to line, and a supplementary contact-arm A', connecting the said contact-pieces, respectively, with a series of resistance-terminals.

6. The combination, in an electrically-propelled vehicle, of a motor and resistance with electrical connections leading therefrom to each end of the car, and combined reversing and regulating switches thereat, each comprising a reversing-switch and a regulating-switch operated by a common handle, whereby the driver may control the motor from either end of the car, as set forth.

7. The combination of an electric motor, and a reversing device comprising contact-plates $a a^x$, connected to opposite terminals of one component part of the motor, and a switch connected directly to line and thrown from one to the other to reverse the motor, but allowed a considerable range of movement while maintaining contact with each, and a current-regulator for the motor controlled by the reversing-switch during its last-named range of movement.

8. The combination, with an electric motor, of contact-plates connected to opposite terminals of one component part of the motor, the resistance, and a combined reversing and regulating switch comprising parts A A', mechanically connected, but electrically insu-

lated from one another, the part A being connected directly to line.

9. In an electrically-propelled vehicle, the combination, with a motor, of a resistance-controlling device therefor at each end of the vehicle, and two reversing-switches for the motor, one for each end of the vehicle.

10. In an electrically-propelled vehicle, the combination of a regulating-resistance, duplicate connections extending oppositely therefrom to switches on opposite ends of the vehicle, and duplicate reversing-connections from one of the component parts of the motor, also extending to reversing-switches on opposite ends of the vehicle, whereby the motor can be regulated and reversed from either end of the car by duplicate switches acting independently of one another.

11. The combination, with an electric motor having its field-magnets and armature in series, and a controlling-resistance, of electrical connections extending from the resistance and one of the component parts of the motor and connected, respectively, to a combined regulating and reversing switch, by which the resistance of the motor-circuit and direction of current-flow through one of its parts are controlled, as set forth.

12. The combination, with an electric motor having armature and field magnets in series, of a resistance in the field-circuit and a combined reversing and controlling switch reversing the current-flow through the armature and introducing a resistance in the field, as set forth.

13. The combination, with an electric motor having a sectional field, of a reversing-switch and circuit-changer for the field-magnet connected and actuated together in a predetermined order.

14. In an electrically-propelled vehicle, the combination, with the motor, of a controlling-resistance, duplicate electrical connections extending therefrom to separate regulating-switches, and duplicate electrical connections extending from the motor to separate reversing-switches adjacent to the regulating-switches, respectively.

15. In an electrically-propelled vehicle, the combination, with the motor, of a controlling-resistance, duplicate electrical connections extending therefrom to separate regulating-switches having duplicate sets of contact-pieces, and duplicate electrical connections extending from the motor to two separate reversing-switches, respectively.

FRANCIS O. BLACKWELL.

Witnesses:

EDWARD M. BENTLEY,
G. RENAULT.