

(12) STANDARD PATENT
(19) AUSTRALIAN PATENT OFFICE

(11) Application No. **AU 2001240343 B2**

(54) Title
Thermal expansion compensation for modular printhead assembly

(51)⁷ International Patent Classification(s)
B41J 002/14

(21) Application No: **2001240343** (22) Date of Filing: **2001.03.09**

(87) WIPO No: **WO01/66357**

(30) Priority Data

(31) Number	(32) Date	(33) Country
PQ6111	2000.03.09	AU

(43) Publication Date: **2001.09.17**

(43) Publication Journal Date: **2001.11.29**

(44) Accepted Journal Date: **2004.07.29**

(71) Applicant(s)
Silverbrook Research Pty Ltd

(72) Inventor(s)
Silverbrook, Kia

(74) Agent / Attorney
Silverbrook Research Pty. Ltd., 393 Darling Street, Balmain, NSW, 2041

(56) Related Art
JP 11-010861
JP 2000280496

(12) INTERNATIONAL APPLICATION PUBLISHED UNDER THE PATENT COOPERATION TREATY (PCT)

(19) World Intellectual Property Organization
International Bureau



(43) International Publication Date
13 September 2001 (13.09.2001)

PCT

(10) International Publication Number
WO 01/66357 A1

- (51) International Patent Classification⁷: **B41J 2/14**
- (21) International Application Number: PCT/AU01/00260
- (22) International Filing Date: 9 March 2001 (09.03.2001)
- (25) Filing Language: English
- (26) Publication Language: English
- (30) Priority Data:
PQ 6111 9 March 2000 (09.03.2000) AU
- (71) Applicant (for all designated States except US): **SILVERBROOK RESEARCH PTY LTD** [AU/AU]; 393 Darling Street, Balmain, New South Wales 2041 (AU).
- (72) Inventor; and
- (75) Inventor/Applicant (for US only): **SILVERBROOK, Kia** [AU/AU]; Silverbrook Research Pty Ltd, 393 Darling Street, Balmain, New South Wales 2041 (AU).
- (74) Agent: **SILVERBROOK, Kia**; Silverbrook Research Pty Ltd, 393 Darling Street, Balmain, New South Wales 2041 (AU).
- (81) Designated States (national): AE, AG, AL, AM, AT, AU, AZ, BA, BB, BG, BR, BY, BZ, CA, CH, CN, CO, CR, CU, CZ, DE, DK, DM, DZ, EE, ES, FI, GB, GD, GE, GH, GM, HR, HU, ID, IL, IN, IS, JP, KE, KG, KP, KR, KZ, LC, LK, LR, LS, LT, LU, LV, MA, MD, MG, MK, MN, MW, MX, MZ, NO, NZ, PL, PT, RO, RU, SD, SE, SG, SI, SK, SL, TJ, TM, TR, TT, TZ, UA, UG, US, UZ, VN, YU, ZA, ZW.
- (84) Designated States (regional): ARIPO patent (GH, GM, KE, LS, MW, MZ, SD, SL, SZ, TZ, UG, ZW), Eurasian patent (AM, AZ, BY, KG, KZ, MD, RU, TJ, TM), European patent (AT, BE, CH, CY, DE, DK, ES, FI, FR, GB, GR, IE, IT, LU, MC, NL, PT, SE, TR), OAPI patent (BF, BJ, CF, CG, CI, CM, GA, GN, GW, ML, MR, NE, SN, TD, TG).
- Published:
with international search report
- For two-letter codes and other abbreviations, refer to the "Guidance Notes on Codes and Abbreviations" appearing at the beginning of each regular issue of the PCT Gazette.

(54) Title: THERMAL EXPANSION COMPENSATION FOR MODULAR PRINTHEAD ASSEMBLY

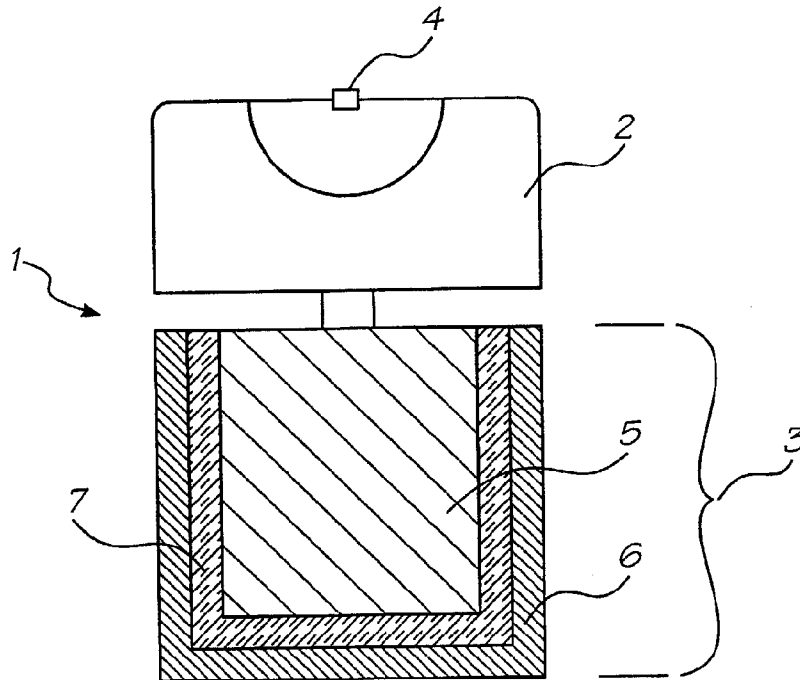

(57) Abstract: A method for aligning two or more printhead modules (2) mounted to a support member (3) in a printer, the method including: positioning the printhead modules (2) on the support member (3) such that they align when the support member (3) is at its operating temperature but not necessarily at other temperatures.



WO 01/66357 A1

Title

Thermal Expansion Compensation for Modular Printhead Assembly.

Field of the Invention

The present invention relates to printers, and in particular to digital inkjet printers.

5 Co-Pending Applications.

Various methods, systems and apparatus relating to the present invention are disclosed in the following co-pending applications filed by the applicant or assignee of the present invention on 24 May 2000:

	PCT/AU00/00578	PCT/AU00/00579	PCT/AU00/00581	PCT/AU00/00580
10	PCT/AU00/00582	PCT/AU00/00587	PCT/AU00/00588	PCT/AU00/00589
	PCT/AU00/00583	PCT/AU00/00593	PCT/AU00/00590	PCT/AU00/00591
	PCT/AU00/00592	PCT/AU00/00584	PCT/AU00/00585	PCT/AU00/00586
	PCT/AU00/00594	PCT/AU00/00595	PCT/AU00/00596	PCT/AU00/00597
	PCT/AU00/00598	PCT/AU00/00516	PCT/AU00/00517	PCT/AU00/00511

15 Various methods, systems and apparatus relating to the present invention are disclosed in the following co-pending application, PCT/AU00/01445, filed by the applicant or assignee of the present invention on 27 November 2000. The disclosures of these co-pending applications are incorporated herein by cross-reference. Also incorporated by cross-reference are the disclosures of two co-filed PCT applications, PCT/AU01/00261 and
20 PCT/AU01/00259 (deriving priority from Australian Provisional Patent Application No. PQ6110 and PQ6158). Further incorporated are the disclosures of two co-pending PCT applications filed 6 March 2001, application numbers PCT/AU01/00238 and

- 2 -

PCT/AU01/00239, which derive their priority from Australian Provisional Patent Application nos. PQ6059 and PQ6058.

Background of the Invention

Recently, inkjet printers have been developed which use printheads manufactured by
5 micro-electro mechanical systems (MEMS) techniques. Such printheads have arrays of
microscopic ink ejector nozzles formed in a silicon chip using MEMS manufacturing
techniques. The invention will be described with particular reference to silicon printhead
chips for digital inkjet printers wherein the nozzles, chambers and actuators of the chip are
formed using MEMS techniques. However, it will be appreciated that this is in no way
10 restrictive and the invention may also be used in many other applications.

Silicon printhead chips are well suited for use in pagewidth printers having stationary
printheads. These printhead chips extend the width of a page instead of traversing back and
forth across the page, thereby increasing printing speeds. The probability of a production
defect in an eight inch long chip is much higher than a one inch chip. The high defect rate
15 translates into relatively high production and operating costs.

To reduce the production and operating costs of pagewidth printers, the printhead may
be made up of a series of separate printhead modules mounted adjacent one another, each
module having its own printhead chip. To ensure that there are no gaps or overlaps in the
printing produced by adjacent printhead modules it is necessary to accurately align the
20 modules after they have been mounted to a support beam. Once aligned, the printing from
each module precisely abuts the printing from adjacent modules.

- 3 -

Unfortunately, the alignment of the printhead modules at ambient temperature will change when the support beam expands as it heats up to the temperature it maintains during operation.

Summary of the Invention

5 Accordingly, the present invention provides a system for aligning two or more printhead modules mounted to a support member in a printer, the system including:

positioning the printhead modules on the support member such that they align when the support member is at its operating temperature but not necessarily at other temperatures.

Preferably, the support member is a beam and the printhead modules include MEMS
10 manufactured chips having at least one fiducial on each;

wherein,

the fiducials are used to misalign the printhead modules by a distance calculated from:

- i) the difference between the coefficient of thermal expansion of the beam and the printhead chips;
- 15 ii) the spacing of the printhead chips along the beam; and,
- iii) the difference between the production temperature and the operating temperature.

Conveniently, the beam may have a core of silicon and an outer metal shell. In a further preferred embodiment, the beam is adapted to allow limited relative movement
20 between the silicon core and the metal shell. To achieve this, the beam may include an elastomeric layer interposed between the silicon core and metal shell. In other forms, the outer shell may be formed from laminated layers of at least two different metals.

- 4 -

It will be appreciated that this system requires the coefficient of thermal expansion of the printhead chips to be greater than or equal to the coefficient of thermal expansion of the beam, otherwise the "gaps" left between the printhead modules as compensation at ambient temperature will not close as the beam reaches the operating temperature.

5 **Brief Description of the Drawing**

A preferred embodiment of the invention will now be described, by way of example only, with reference to the accompanying drawing in which:

Figure 1 shows a schematic cross section of a printhead assembly according to the present invention.

10 **Detailed Description of Preferred Embodiments**

Referring to the figure the printhead assembly 1 has a plurality of printhead modules 2 mounted to a support member 3 in a printer (not shown). The printhead module includes a silicon printhead chip 4 in which the nozzles, chambers, and actuators are manufactured using MEMS techniques. Each printhead chip 4 has at least 1 fiducial (not shown) for
15 aligning the printheads. Fiducials are reference markings placed on silicon chips and the like so that they may be accurately positioned using a microscope.

According to one embodiment of the invention, the printheads are aligned while the printer is operational and the assembly is at the printing temperature. If it is not possible to view the fiducial marks while the printer is operating, an alternative system of alignment is
20 to misalign the printhead modules on the support beam 3 such that when the printhead assembly heats up to the operating temperature, the printheads move into alignment. This is easily achieved by adjusting the microscope by the set amount of misalignment required or simply misaligning the printhead modules by the required amount.

- 5 -

The required amount is calculated using the difference between the coefficients of thermal expansion of the printhead modules and the support beam, the length of each individual printhead module and the difference between ambient temperature and the operating temperature. The printer is designed to operate with acceptable module alignment within a temperature range that will encompass the vast majority of environments in which it expected to work. A typical temperature range may be 0⁰C to 40⁰C. During operation, the operating temperature of the printhead rise a fixed amount above the ambient temperature in which the printer is operating at the time. Say this increase is 50⁰C, the temperature range in which the alignment of the modules must be within the acceptable limits is 50⁰C to 90⁰C. Therefore, when misaligning the modules during production of the printhead, the production temperature should be carefully maintained at 20⁰C to ensure that the alignment is within acceptable limits for the entire range of predetermined ambient temperatures (i.e. 0⁰C to 40⁰C).

To minimize the difference in coefficient of thermal expansion between the printhead modules and the support beam 3, the support beam has a silicon core 5 mounted within a metal channel 6. The metal channel 6 provides a strong cost effective structure for mounting within a printer while the silicon core provides the mounting points for the printhead modules and also helps to reduce the coefficient of thermal expansion of the support beam 3 as a whole. To further isolate the silicon core from the high coefficient of thermal expansion in the metal channel 6 an elastomeric layer 7 is positioned between the core 5 and the channel 6. The elastomeric layer 7 allows limited movement between the metal channel 6 and the silicon core 5.

- 6 -

The invention has been described with reference to specific embodiments. The ordinary worker in this field will readily recognise that the invention may be embodied in many other forms.

CLAIMS :-

1. A method for aligning two or more printhead modules mounted to a support member in a printer, the method including:
 - positioning the printhead modules on the support member such that they align when
 - 5 the support member is at its operating temperature but not necessarily at other temperatures.

2. A system for aligning a plurality of printhead modules mounted on a support member in a printer wherein the support member is a beam and the printhead modules include MEMS manufactured chips having at least one fiducial on each;
 - 10 wherein,
 - the fiducials are used to misalign the printhead modules at ambient temperature by a distance calculated from:
 - i) the difference in coefficient thermal expansion between the beam and the printhead chips;
 - 15 ii) the spacing of the printhead chips along the beam; and,
 - iii) the difference between the production temperature and the operatingtemperature.

3. A system for aligning a plurality of printhead modules mounted to a support member
- 20 and a printer according to claim 2 wherein the beam has a core of silicon and an outer metal shell.

- 8 -

4. A system for aligning a plurality of printhead modules mounted to a support member in a printer according to claim 3 wherein the beam is adapted to allow limited relative movement between the silicon core and the metal shell.

- 5 5. A system for aligning a plurality of printhead modules mounted to a support member in a printer according to claim 4 wherein the beam has an elastomeric layer between the silicon core and metal shell to permit the limited relative movement.

6. A system for aligning a plurality of printhead modules mounted to a support member
10 in a printer according to claim 5 wherein the outer shell is formed from laminated layers of at least two different metals.

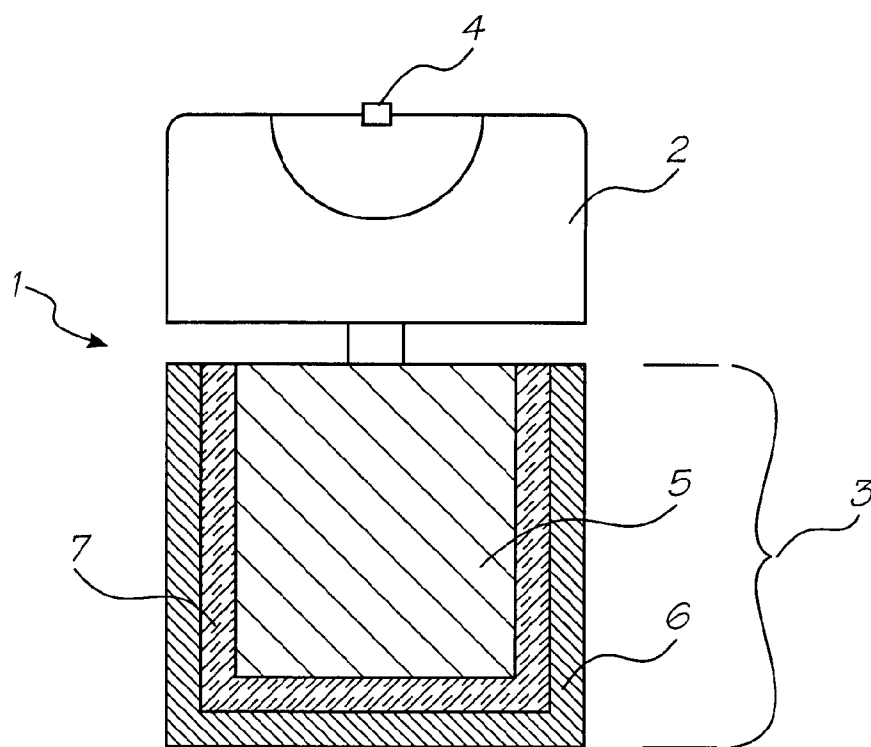

FIG. 1