

(No Model.)

3 Sheets—Sheet I.

M. CAMPBELL.

ADJUSTING MEANS FOR BELT SHIFTING MECHANISM OF ROVING FRAMES.

No. 525,531.

Patented Sept. 4, 1894.

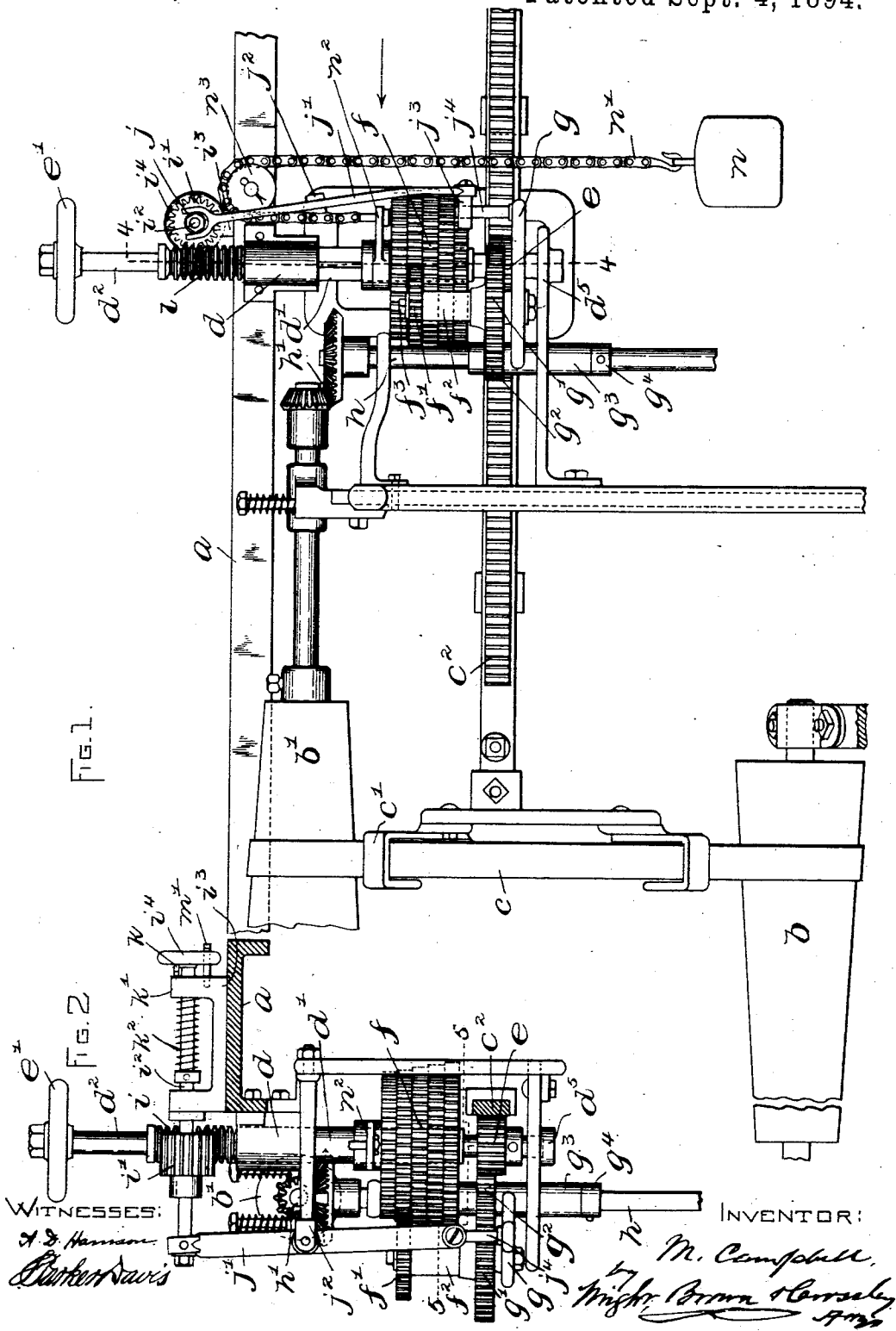

WITNESSES:
A. S. Hammon
Charles Davis

INVENTOR:
M. Campbell
 by *Wm. Brown & Co.*
 177

(No Model.)

3 Sheets—Sheet 2.

M. CAMPBELL.

ADJUSTING MEANS FOR BELT SHIFTING MECHANISM OF ROVING FRAMES.

No. 525,531.

Patented Sept. 4, 1894.

FIG. 3.

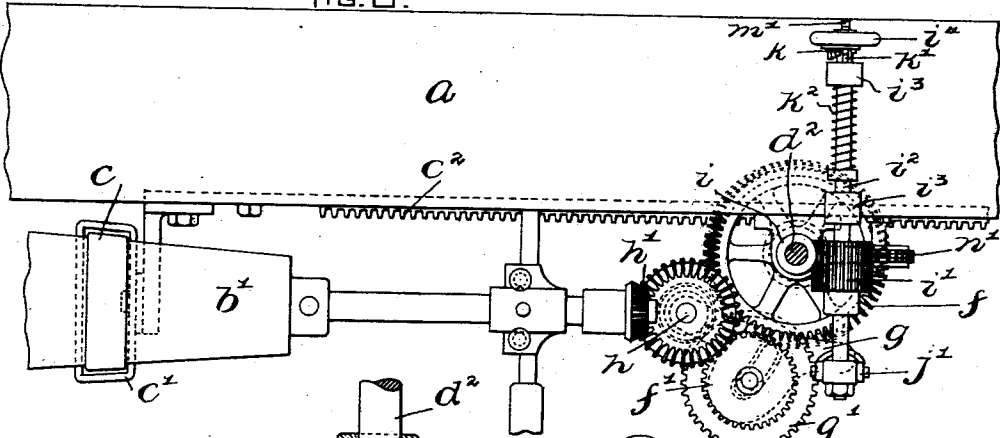

FIG. 6.

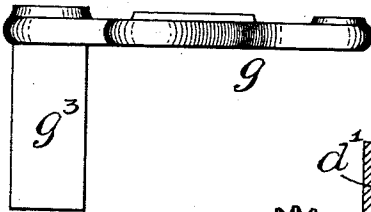

FIG. 7.

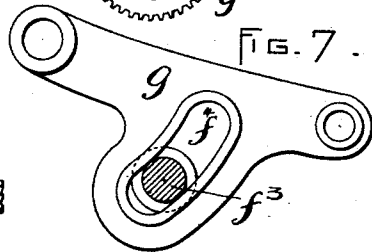

FIG. 4.

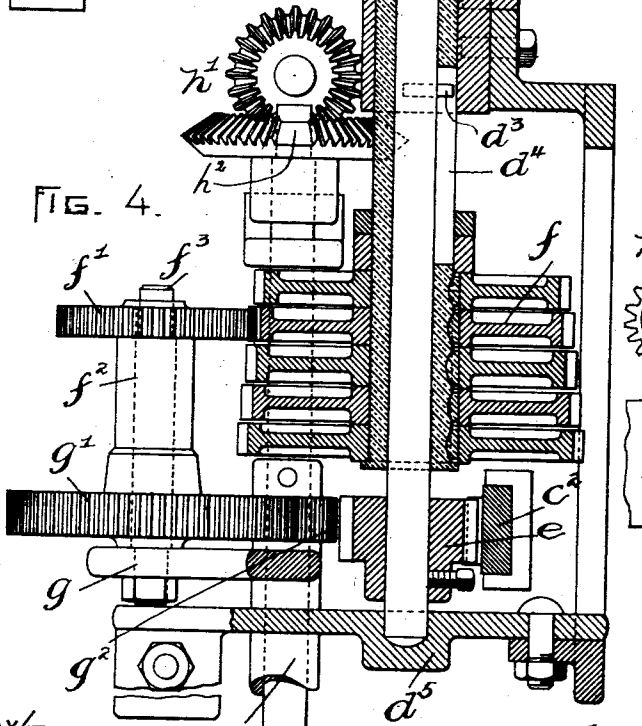
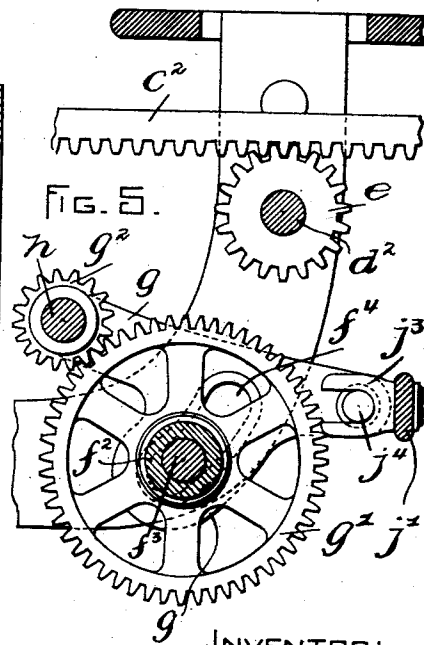

FIG. 5.



WITNESSES:

A. D. Hanson
Parker Davis

INVENTOR:

M. Campbell.
by Knight, Brown & Kenney.
Attys.

(No Model.)

3 Sheets—Sheet 3.

M. CAMPBELL.

ADJUSTING MEANS FOR BELT SHIFTING MECHANISM OF ROVING FRAMES.

No. 525,531.

Patented Sept. 4, 1894.

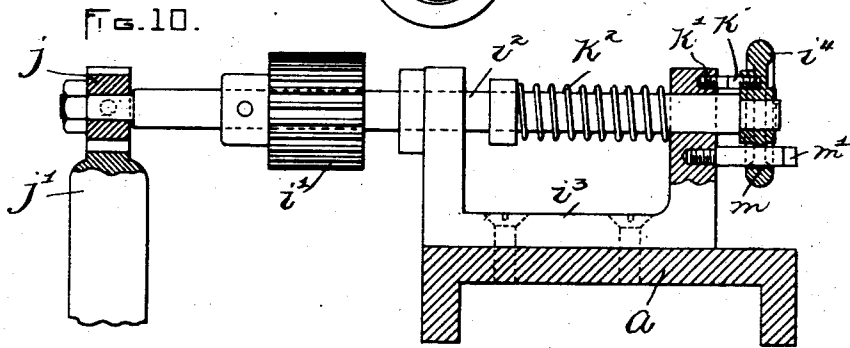
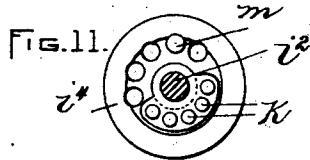
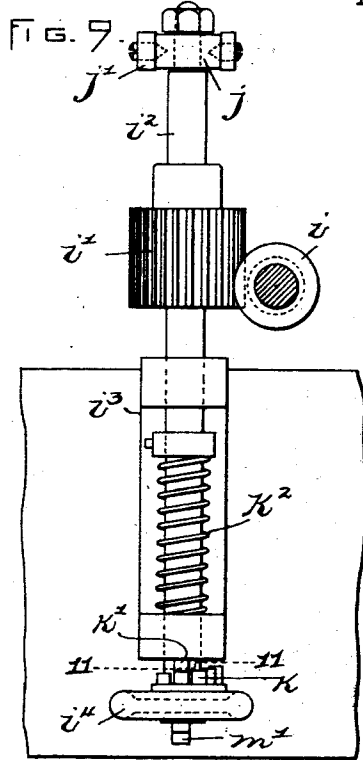
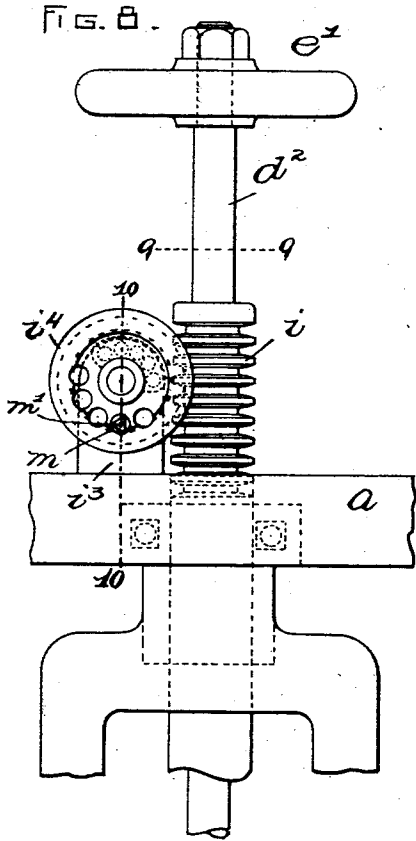

WITNESSES:

A. D. Harmon
Charles Davis

INVENTOR:

by M. Campbell
Wright, Brown & Kennedy

UNITED STATES PATENT OFFICE.

MALCOLM CAMPBELL, OF BOSTON, MASSACHUSETTS.

ADJUSTING MEANS FOR BELT-SHIFTING MECHANISM OF ROVING-FRAMES.

SPECIFICATION forming part of Letters Patent No. 525,531, dated September 4, 1894.

Application filed November 7, 1893. Serial No. 490,249. (No model.)

To all whom it may concern:

Be it known that I, MALCOLM CAMPBELL, of Boston, in the county of Suffolk and State of Massachusetts, have invented certain new and useful Improvements in Adjusting Means for Belt-Shifting Mechanism of Roving-Frames, of which the following is a specification.

The object of the present invention is to provide adjusting means in a roving frame by which the length of the step-by-step movement of the belt on the cone-pulleys which intermittently decreases the speed of the bobbins with each increase in diameter of the bobbins by reason of the winding on of the rovings, may be varied by operating a handle under control of the attendant whereby the decrease in speed may be regulated so as to maintain a proper tension of the rovings.

The accompanying drawings illustrate an embodiment of the invention.

Figure 1 shows a rear elevation of a portion of a roving frame embodying the invention. Fig. 2 shows an end elevation looking in the direction of the arrow in Fig. 1. Fig. 3 shows a top plan view. Fig. 4 shows a section on line 4-4 of Fig. 1, on an enlarged scale. Fig. 5 shows a section on line 5-5 of Fig. 2. Figs. 6 and 7 show details of a swinging gear-supporting bracket. Fig. 8 shows a front elevation on an enlarged scale of the handle and intermediate connections. Figs. 9 and 10 show sections on lines 9-9 and 10-10 respectively of Fig. 8. Fig. 11 shows a section on line 11-11 of Fig. 9.

The letter *a* designates a supporting rail of the machine; *b*, the driving cone-pulley; *b'* the driven cone-pulley; *c*, the belt engaging said pulleys; *c'*, the holder embracing the belt, and *c²* a rack connected with said holder. Intermittent motion is transmitted to the said rack through means hereinafter described, whereby the belt is moved step-by-step from the fast to the slow end of the pulleys to accommodate the speed of the bobbins to the increasing diameter of the windings on the bobbins, a common and well-known expedient in this class of machines. A bearing *d* on the rail *a* embraces a rotatable and vertically movable sleeve *d'* through which extends a spindle *d²* rotatively connected with it by means of a pin *d³* engaging a slot *d⁴* in the sleeve whereby the sleeve is permitted to

slide on the spindle. The spindle *d²* is stepped at its lower end in a fixed bearing *d⁵*, and has affixed to it a pinion *e* in mesh with the rack *c²*, and said spindle carries a hand-wheel *e'* at its upper end which is employed in running the belt back to the fast end of the cone-pulleys when a new set of bobbins is to be wound.

The sleeve *d'* has affixed to it a number of gears *f* arranged one above the other and of varying sizes, the top one having the least number of teeth, and the others increasing in the number of teeth toward the bottom one which has the greatest number of teeth. A gear *f'* is adapted to mesh with any one of the gears *f* and is affixed to the upper end of a sleeve *f²* mounted on a stud *f³* which is fastened in an adjustment slot *f⁴* of a horizontal swinging bracket *g*. The said sleeve also has affixed to it a gear *g'* which meshes with a spur *g²* affixed to a vertical shaft *h*, and the latter is connected with the pulley *b'*, through bevel-gears *h'*, one of which is mutilated as at *h²* as is customary in this class of mechanism, so as to produce in combination with other devices so old as to require no illustration, an intermittent partial revolution of the shaft *h*, and a corresponding step-by-step movement of the rack *c²*.

The bracket *g* is pivotally supported on the shaft *h* by means of an elongated sleeve *g³*, formed on the bracket and embracing the shaft, and a collar *g⁴* affixed to said shaft on which the said sleeve bears. It will be observed that by swinging the bracket on its pivot, the gear *f'* may be moved toward and away from the gears *f*, and by moving the vertical sleeve *d* in the direction of its length different ones of the gears *f* may be brought to position for engagement with said gear *f'*.

Intermittent motion for shifting the belt step-by-step is transmitted to the rack *c²* through the bevel-gears *h'*, shaft *h*, spur *g²*, gear *g'*, upper gear *f'*, one of the gears *f*, and the pinion *e*. Hence by engaging different ones of the gears *f* with the gear *f'*, the length of the step-by-step movement can be varied according to the number of teeth of the gears *f*.

The means employed for changing the gearing to secure the desired length of the step-by-step movement, are as follows: A circular

rack *i* is formed in the upper part of the sleeve *d'*, and an elongated pinion *i'* engages said rack and is affixed on a longitudinally movable and rotatable spindle *i²* which is supported in bearings *i³* on the rail *a*, and carries a hand-wheel *i⁴* at the front of the frame where it can be conveniently manipulated by the attendant. At the rear end the spindle carries a loose collar *j* to which is pivotally connected the bifurcated upper end of a lever *j'*, pivoted intermediate of its ends to a rigid support *j²* and at its lower end carrying a laterally projecting bifurcated arm *j³* which embraces a pin *j⁴* on the bracket *g*. By moving the spindle *i²* longitudinally the gear *f'* may be swung into and out of mesh with the gears *f* and by turning said spindle the sleeve *d'* may be moved longitudinally to bring any one of the gears *f* into operative position. The means employed to determine the position of the gear *f'* so that it properly meshes with the particular gear *f* with which it is to connect, are as follows: A series of stop-pins *k* graduated as to length are fastened in the inner side of the hand-wheel *i⁴* and are adapted to severally abut a pin *k'* fastened in the bearing *i³*. A spring *k²* tends to draw the hand-wheel toward the bearing. There is a stop-pin *k* for each gear *f*, and when that stop-pin is actuated against the stop-pin *k'*, the gear *f'* is adjusted by the longitudinal movement required of the spindle to bring said pins in line, for engagement with the particular gear *f* with which the stop-pin *k* corresponds.

The means for determining the operative position of the particular gear *f* consist in a series of openings *m* in the hand-wheel *i⁴* corresponding in number with the gears *f* and a pin *m'* adapted to extend through any one of said openings and screw into the bearing *i³*, and designed to be operated by a key. Each opening in the hand-wheel corresponds with one of the gears *f*, and when the hand-wheel is turned so as to bring one of the openings in line with the screw threaded opening in the bearing, the particular gear *f* with which said opening in the hand-wheel corresponds, is brought to position for engagement with the gear *f'*, by reason of the longitudinal movement imparted to the sleeve *d'* by the turning of the spindle *i²*. By introducing the pin *m'*, the parts are locked in the adjustment to which they may have been brought. A counterbalancing weight *n* is connected by means of a chain *n'* with an arm *n²* affixed to the sleeve *d'*, said chain passing over a pulley *n³* in the rail *a*.

Having thus explained the nature of the invention and described a way of constructing and using the same, though without attempting to set forth all of the forms in which it may be made or all of the modes of its use, it is declared that what is claimed is—

1. In a roving frame, the combination of cone-pulleys, a belt engaging the same, means for shifting the belt step-by-step including provisions for varying the length of the step-

by-step movement, and a handle operatively connected with said provisions and controlling their adjustment.

2. In a roving frame, the combination of cone-pulleys, a belt engaging the same, means for shifting the belt step-by-step including change-gears for varying the length of the step-by-step movement, and a handle operatively connected with the change-gears and controlling their adjustment whereby any one of them can be brought into operative position.

3. In a roving frame the combination of cone-pulleys, a belt engaging the same, means for shifting the belt step-by-step including change-gears for varying the length of the step-by-step movement, all said gears having a common axis and movable together to bring any one of them to operative adjustment, and a handle operatively connected with and controlling said gears.

4. In a roving frame the combination of cone-pulleys, a belt engaging the same, means for shifting the belt step-by-step including change-gears for varying the length of the step-by-step movement, all said gears having a common axis and movable together to bring any one of them to operative adjustment, and a laterally-movable gear adapted to mesh with any one of the change-gears, and a handle operatively connected with and controlling the change-gears and the said laterally movable gear.

5. In a roving frame the combination of cone-pulleys, a belt engaging the same, means for shifting the belt step-by-step including change-gears for varying the length of the step-by-step movement, all said gears being on a common support movable in the direction of its length, and a laterally movable gear adapted to mesh with any one of the change-gears; a longitudinally movable and rotatable handle, and suitable connections between said handle and the laterally-movable gear and between said handle and the change-gears, substantially as and for the purpose described.

6. In a roving frame the combination of cone-pulleys, a belt engaging the same, means for shifting the belt step-by-step including change-gears for varying the length of the step-by-step movement, all said gears being on a common support movable in the direction of its length, and a laterally movable gear adapted to mesh with any one of the change-gears, a longitudinally movable and rotatable handle, suitable connections between said handle and the laterally-movable gear and between said handle and the change-gears, graduated stops to determine the longitudinal adjustment of the handle, and means for locking the handle at predetermined points to which it may be turned.

7. In a roving frame the combination of cone-pulleys, a belt engaging the same, means for shifting the belt step-by-step including change-gears for varying the length of the

step-by-step movement, said gears being af-
fixed one above the other on a longitudinally
movable and rotatable sleeve having a circu-
lar rack, and a horizontally swinging support
5 carrying a gear adapted to mesh with any one
of the change-gears, a longitudinally movable
and rotatable spindle carrying a pinion in
mesh with the rack on the change-gear-sup-
porting sleeve, and having a handle, a lever
10 connecting said spindle with the horizontally
swinging gear support, and means for deter-

mining the longitudinal and rotative adjust-
ment of the spindle.

In testimony whereof I have signed my
name to this specification, in the presence of 15
two subscribing witnesses, this 30th day of
October, A. D. 1893.

MALCOLM CAMPBELL.

Witnesses:

ARTHUR W. CROSSLEY,
F. PARKER DAVIS.