

C. H. HASKINS.

TIME INDICATOR FOR TELEPHONE EXCHANGES.

No. 306,395.

Patented Oct. 14, 1884.

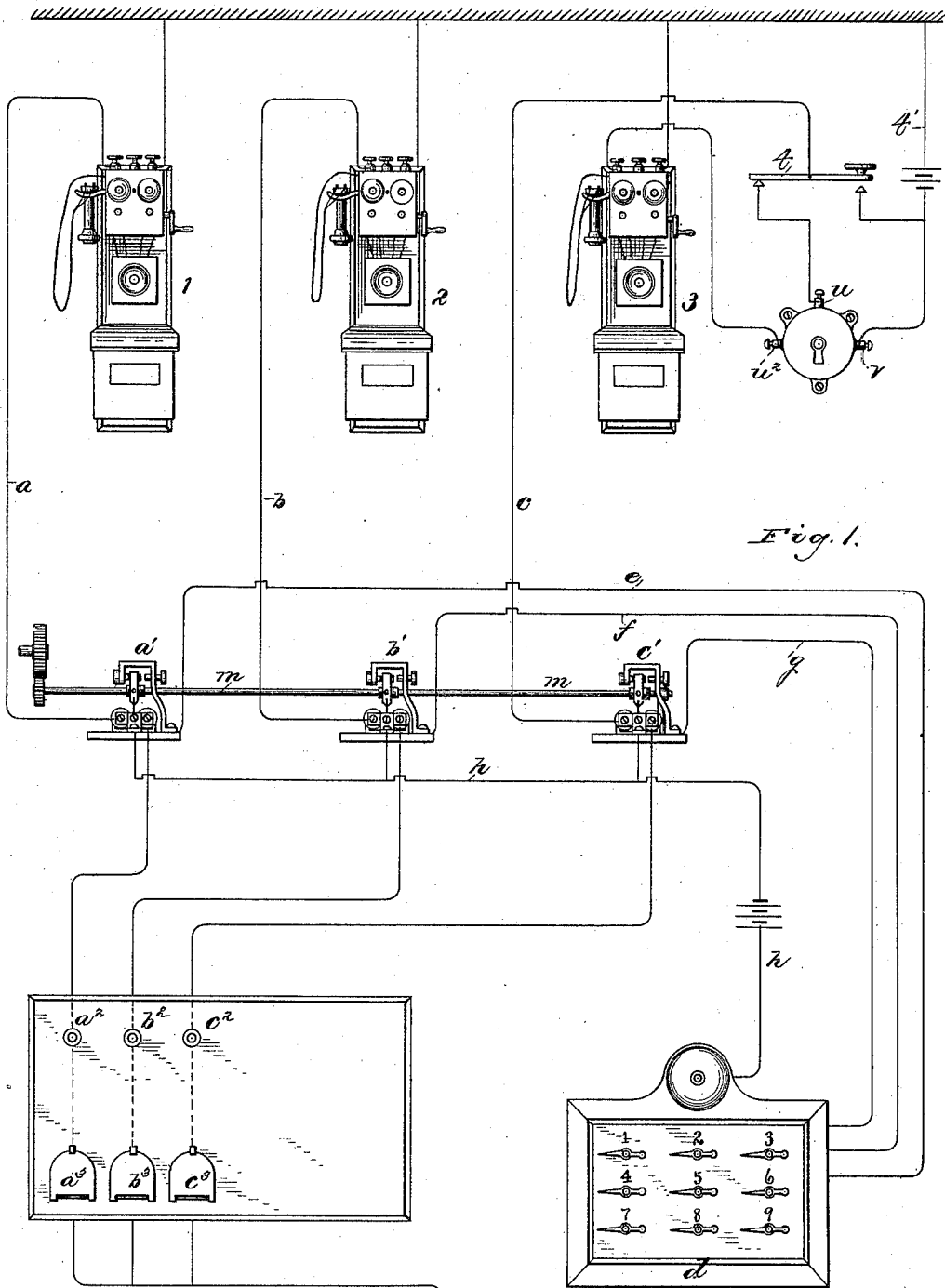

Witnesses.  
*Henry Frankfurter*  
*Saml B. Lover*

Inventor.  
*Charles H. Haskins,*  
 per *George R. Barton*  
 Attorney.

C. H. HASKINS.

TIME INDICATOR FOR TELEPHONE EXCHANGES.

No. 306,395.

Patented Oct. 14, 1884.

Fig. 2.

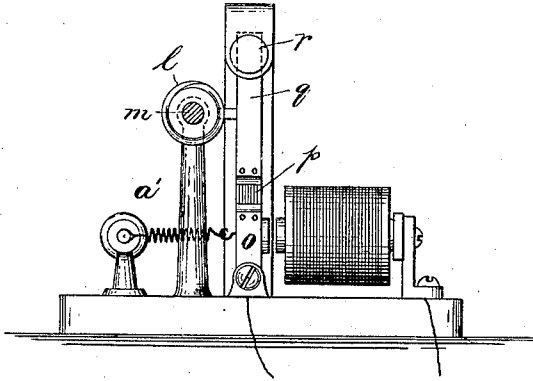

Fig. 3.

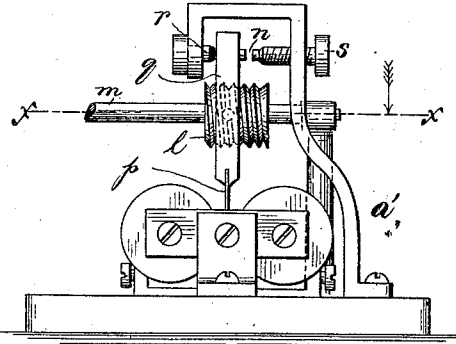

Fig. 4.

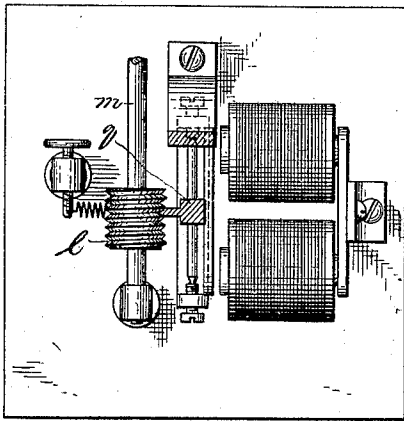
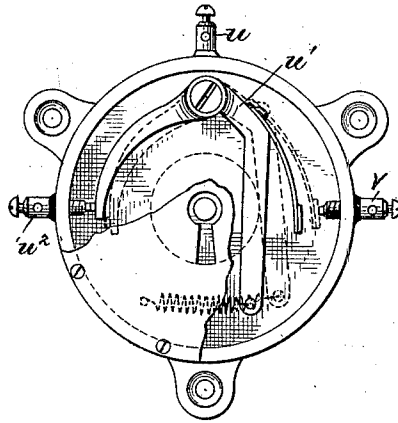

Fig. 5.



Witnesses.

*Henry Frankfurter.*  
*Sam B. Dover.*

Inventor.

*Charles H. Haskins.*  
 per. *George P. Barton*  
 Attorney.

# UNITED STATES PATENT OFFICE.

CHARLES H. HASKINS, OF MILWAUKEE, WISCONSIN.

## TIME-INDICATOR FOR TELEPHONE-EXCHANGES.

SPECIFICATION forming part of Letters Patent No. 306,395, dated October 14, 1884.

Application filed June 13, 1884. (No model.)

*To all whom it may concern:*

Be it known that I, CHARLES H. HASKINS, a citizen of the United States, residing at Milwaukee, in the county of Milwaukee and State of Wisconsin, have invented a certain new and useful Improvement in Time-Indicators for Telephone-Exchanges, of which the following is a full, clear, concise, and exact description, reference being had to the accompanying drawings, forming a part of this specification.

My invention relates to time-indicators for telephone-exchanges; and it consists in electric signaling apparatus operated automatically, whereby a signal will be sent from a subscriber's station to the central office at the close of a given space of time in case the watchman fails to perform certain required duties. The apparatus which I have invented for this purpose consists of a screw or screws provided on a shaft turned by clock-work or other means at any desired rate of speed, and circuit-closers, one for each station, which is provided with the time-service, the said circuit-closers being provided with adjustable armatures, which are carried by the screw upon the revolving shaft, in combination with an annunciator at the central office and circuits, as herein described and claimed. The screw tends to carry the armature-levers into contact with local contact-points placed, respectively, in the different local circuits. The watchman at a given subscriber's station, by turning the generator or closing the circuit of a battery to line, may lift the armature from time to time from the screw, thus allowing the armature to return to the zero-point, thereby preventing the armature from closing the local circuit. As long, therefore, as the annunciator makes no indication, it will be evidence that the watchman is doing his duty. If it is not convenient to place the telephone call-box so as to be accessible to the watchman, I provide a local battery and switching apparatus in some convenient position, so that the watchman may, by pressing a key, close the battery to line, thus energizing the electro-magnet of the circuit-closer at stated intervals, so as to lift the point or knife edge of the armature from the screw, and allow said armature, actuated by the force of a spring, to be carried back to the stop which

marks the zero-point. This push-key I make, preferably, in the form of a lock with a key fitted thereto. The lock may thus be placed on the outside of a building, and cannot be operated to close the circuit except by the watchman who holds the key. I arrange for cutting out or shunting the circuit-closers from the circuit during the day, so as to remove the resistance of their coils from the telephone-circuits.

In the accompanying drawings, which are illustrative of my invention, Figure 1 is a diagram showing three subscribers' stations connected with the central office and provided with my watchman's time-detector. Fig. 2 is a side view of one of the circuit-closers in combination with the screw. Fig. 3 is an end view of the same. Fig. 4 is a top view, as seen from section-line *xx* of Fig. 3. Fig. 5 is a detailed view of the lock or circuit-closer.

Like parts are indicated by similar letters of reference in the different figures.

In Fig. 1 I have shown a diagram illustrating three subscribers' stations, 1, 2, and 3, provided with my watchman's time-detector, with their telephone-lines *a*, *b*, and *c* connected, respectively, through their circuit-closers *a'*, *b'*, *c'*, and with spring-jack switches *a<sup>2</sup>*, *b<sup>2</sup>*, *c<sup>2</sup>* and annunciator-drops *a<sup>3</sup>*, *b<sup>3</sup>*, *c<sup>3</sup>* upon the switch-board at the central office.

I have not illustrated the connecting-cords and plugs and the operator's telephone and apparatus at the central office, since any well-known form of connecting devices and apparatus for receiving and answering the calls may be used, and the same form no part of my invention herein claimed.

The annunciator *d* is placed at the central station, and should be provided with a number or indication for each station that is to be provided with the time-signal. Any well-known form of annunciator may be used. I have illustrated the form known as the "needle-annunciator." The local circuits *e f g* are connected with the circuit-closers *a' b' c'* and with the battery-wire *h*, as shown. These local circuits *e f g* are normally open at the circuit-closers.

I will now describe the circuit-closers in detail, as shown more clearly in Figs. 2, 3, and 4, in connection with the screws *l*, carried on

the shaft *m*, as shown in Fig. 1. The coils of the electro-magnets are included in the circuit of a telephone-line. The local circuits are normally open at the circuit-closers, as indicated at *n*, Fig. 3. The movement of the shaft *m*, turned by clock-work or other power, keeps the screw *l* of the different circuit-closers turning constantly and at a uniform rate of speed. The armature-lever *o* is connected by the flat spring *p* with the movable contact-piece *q*, which is provided with a stud or a projection like a knife-edge, which normally meshes with the screw. When the current is sent through the coils of the magnet of a circuit-closer, the contact-piece *q* is lifted from the screw *l*, and the tension of the spring *p*, by which it is connected to the armature-lever, is sufficient to carry the movable contact-piece *q* back to the zero-point against the stop *r*, as shown. The contact-point *s* may be adjusted so that the piece *q* may have any desired space to traverse carried by screw *l* before closing the local signal-circuit at *n*.

At subscriber's station 3 I have shown a battery and switching apparatus, whereby current may be sent to line *c* to operate the circuit-closer *c'* without using the generator of the call-box. The switch *t* may be of any suitable form for cutting out or shunting the subscriber's bell and closing the battery *t'* to line. I have used an ordinary push-key for doing this work. I prefer, however, the form of switch shown in Fig. 5, which is in the form of a lock with a key fitted thereto. The telephone-line is connected by binding-post *u* to the frame of the lock, and thence through the lever *u'* to the binding-post *u''*, and thence through the telephone call-box to ground. By inserting a key in the key-hole of the lock and turning it around once, the lever *u'* will for a moment be closed with the contact-point of binding-post *v* of the battery, as indicated by the dotted lines in Fig. 5. A current will thus be sent to line *c*, and the armature *o* of the circuit-closer will be drawn to the poles of the electro-magnet of the circuit-closer. The traveling contact-piece *q* of the circuit-closer thus from time to time may be brought back to the zero-point by the watchman who holds the key to the lock. The shaft is provided with a screw, which may be in sections, as shown, or it may be continuous. A single shaft may thus be utilized to operate as many circuit-closers as may be desired; and by adjusting the distance traversed by the movable piece *q* of any given circuit-closer the time within which the watchman must send current to line to keep the circuit-closer open may be fixed at different intervals for different stations, though the movable pieces *q* are carried at the same rate by the same screw, or different sections of the same screw, as shown and described. Thus the watchman at station 1 may be required to send current to line every fifteen minutes, the watchman at station 2 once in thirty minutes, and the watchman at sta-

tion 3 once an hour, by simply adjusting the speed of the shaft and the distance between the stop *r* and contact *s* of the different circuit-closers. I have shown the flat spring *p* for bringing the piece *q* back to the stop *r* when released from the screw by closing the circuit-closer; but other forms of spring might be employed with the same result. I have shown normally-open circuits *efg* connected to the circuit-closers. It is evident, however, that normally-closed circuits might be used by simply adapting the relay to open the circuit unless the movable piece is carried back in time to the zero-point.

There are other changes in the construction of the various parts that would readily suggest themselves to one acquainted with electric devices, and I therefore do not limit my invention to the specific mechanism shown.

I claim as new and desire to secure by Letters Patent—

1. The combination, substantially as hereinbefore set forth, with the threaded revolving shaft, of the traveling contact-pieces connected with the armature-levers and meshing with the screw or thread of the shaft, the telephone-lines each including the coil of the electro-magnet of its circuit-closer, and a battery or magneto-generator and switching apparatus at the different stations, whereby the different traveling contact-pieces may be brought to the zero-point.

2. The revolving shaft provided with screw *l*, in combination with the traveling contact-pieces, the annunciator provided with a number or indication for each of the different stations, the annunciator-circuits controlled by the traveling contact-pieces, the telephone-lines, and electric apparatus at each station, whereby current may be sent through the circuit-closers, respectively, from the different stations at any desired interval, substantially as and for the purpose specified.

3. The combination, with a telephone-line of a circuit-closer at the central office, a local annunciator-circuit controlled by a traveling contact-piece meshing with a revolving screw, a battery and switch at the subscriber's station, and a retractile spring, whereby the traveling contact-piece is brought back to the zero-point when current is sent to line from the subscriber's station, substantially as and for the purpose specified.

4. The combination, with a telephone-line of a battery and key at the subscriber's station, a relay or circuit-closer at the central office, the armature-lever of the relay connected by a spring with a contact-piece carried by a screw, and a local battery connected through a signaling device to said contact-piece and to an opposing stationary contact-point, whereby the local battery-circuit is closed at the end of a fixed interval by the movement of the contact-piece carried by the screw, substantially as and for the purpose specified.

5. The shaft provided with a screw, the

traveling contact-piece, the stop and adjustable opposing contact-point, the telephone-line, and electric apparatus at the subscriber's station, whereby the traveling contact-piece may be adjusted to close upon the contact-point at the close of any interval desired, while the watchman by sending current to line may bring the movable piece to the zero-point, substantially as and for the purpose specified.

In witness whereof I do hereunto subscribe in my name this 9th day of June, A. D. 1884.

CHARLES H. HASKINS.

Witnesses:

S. G. LAPHAM,  
A. P. GREENE.