

G. VINE.  
ROLL TURNING MACHINE.

No. 522,924.

Patented July 10, 1894.

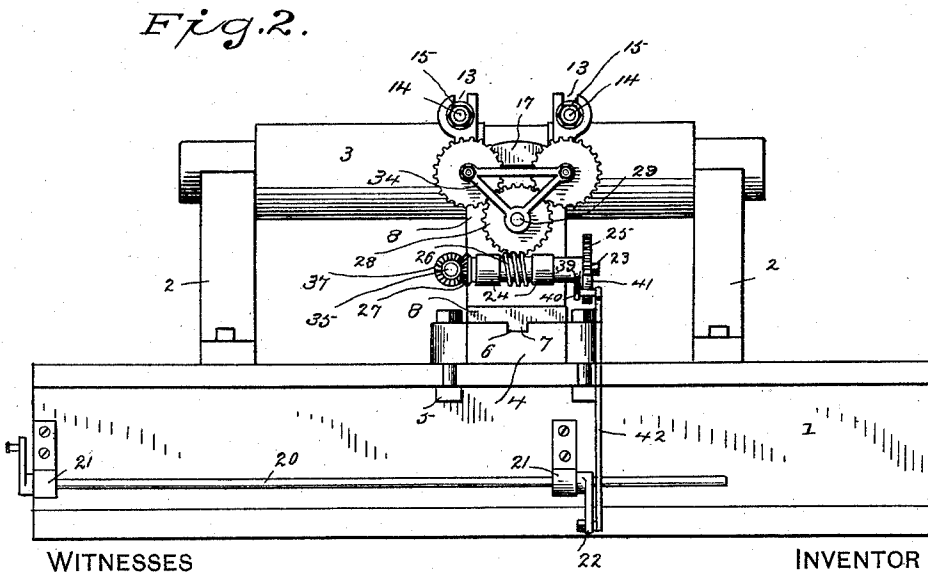
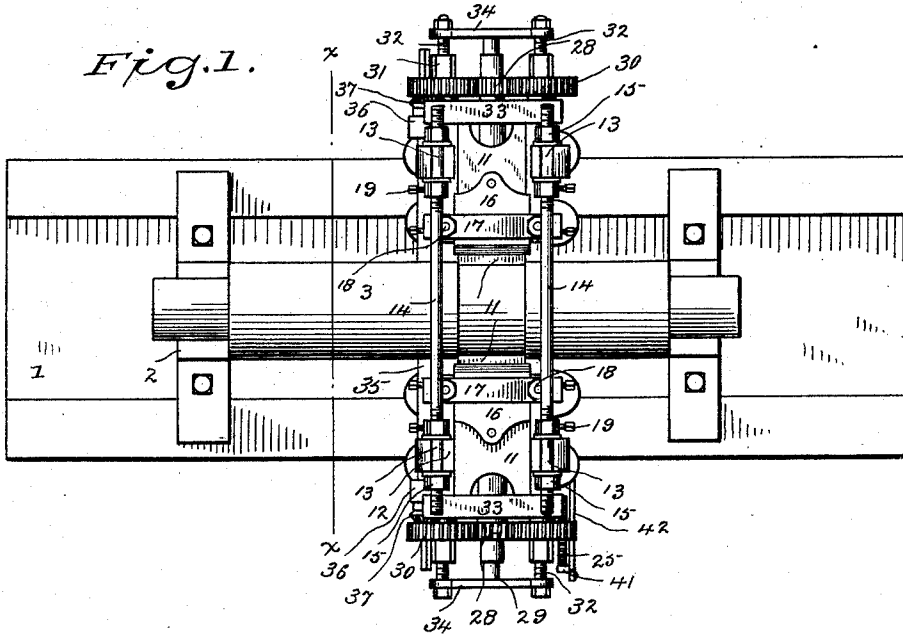

WITNESSES

INVENTOR

*H. A. Lamb,  
Susie T. Richardson.*

*George Vine  
By A. M. Wooster  
Att'y.*

G. VINE.  
ROLL TURNING MACHINE.

No. 522,924.

Patented July 10, 1894.

Fig. 3.

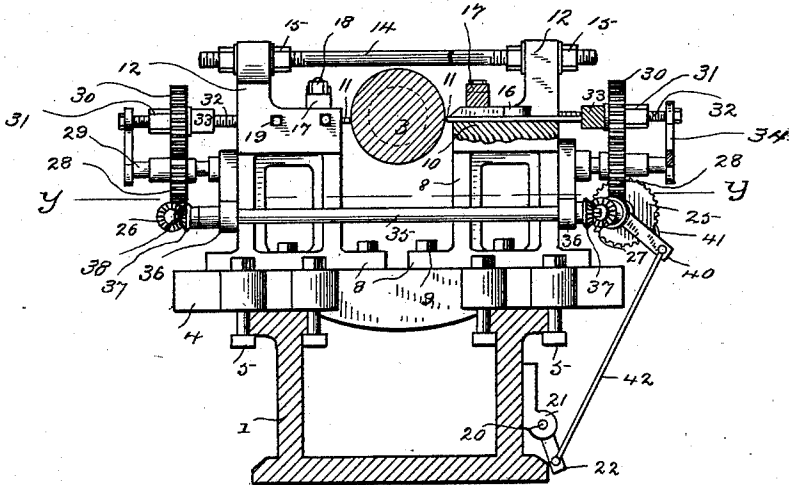
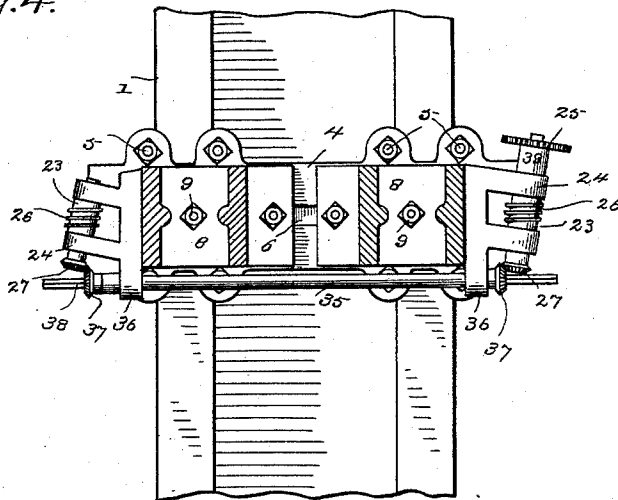

Fig. 4.



WITNESSES

*H. A. Lamb*  
*Lucie T. Richardson*

INVENTOR

*George Vine*  
By *A. M. Wooster*  
Atty.

# UNITED STATES PATENT OFFICE.

GEORGE VINE, OF ANSONIA, CONNECTICUT.

## ROLL-TURNING MACHINE.

SPECIFICATION forming part of Letters Patent No. 522,924, dated July 10, 1894.

Application filed January 2, 1894. Serial No. 495,340. (No model.)

*To all whom it may concern:*

Be it known that I, GEORGE VINE, a citizen of the United States, residing at Ansonia, in the county of New Haven and State of Connecticut, have invented certain new and useful Improvements in Roll-Turning Machines; and I do hereby declare the following to be a full, clear, and exact description of the invention, such as will enable others skilled in the art to which it appertains to make and use the same.

My invention has for its object to improve the construction of roll turning machines so that the quality of work shall be greatly improved and the capacity of the machine shall be increased. This I accomplish by so organizing and constructing the machine that the cutters will be held rigidly at all times without strain upon the roll, thereby insuring that the line of the cut upon the roll will be perfectly straight and uniform, the use of duplicate sets of cutters if required is provided for, likewise a uniform automatic feed for the sets of cutters in addition to a hand feed for each set of cutters.

With these ends in view I have devised the novel mechanism of which the following description in connection with the accompanying drawings is a specification, numbers being used to designate the several parts.

Figure 1 is a plan view illustrating the carriages for a single set of cutters in operative position; Fig. 2 an end elevation corresponding therewith; Fig. 3 a section on the line  $xx$  in Fig. 1 looking toward the right, and Fig. 4 a section on the line  $yy$  in Fig. 3 looking down.

1 denotes a bed which may be of ordinary or any preferred construction, 2, standards adjustably clamped to the bed by which the roll 3 that is to be operated upon is supported. Any suitable mechanism may be used for imparting rotary motion to the roll. As this mechanism forms no portion of my present invention it has been omitted from the drawings for the sake of clearness.

4 denotes a table which is adapted to be moved longitudinally upon the bed and which is rigidly secured thereto after adjustment by bolts 5. This table is provided with a central longitudinal groove 6 to receive ribs 7 on

carriages 8 which are adapted to be moved longitudinally on the table, that is, transversely to the bed.

The special design of the carriages is not of the essence of my invention. They are adapted to be moved in or out upon the table in adjusting the machine to different sizes of rolls, and after adjustment are rigidly secured to the table by bolts 9. The essential requirements are that each carriage be provided with a rest 10 for a cutter 11 and with standards 12 which extend upward above the rests and are provided with sockets 13 which receive transverse strengthening rods 14. The ends of these rods are threaded and are provided with nuts 15 which are adapted to be turned up against the opposite sides of the standards as clearly shown in Fig. 1. These sockets and strengthening rods constitute in connection with bolts 9 an important feature of my invention for the reason that they make the carriages rigid relatively to each other as well as to the table.

In placing a roll in the machine to be operated upon the strengthening rods 14 are of course removed and bolts 9 are loosened. This permits the carriages to be moved in or out. After the carriages have been adjusted their bases are locked rigidly to the table by bolts 9 after which rods 14 are placed in the sockets and the parts are made rigid by tightening up nuts 15 on opposite sides of the standards. It will thus be seen that springing of the parts is rendered practically impossible.

16 denotes blocks which rest on the cutters and are held firmly in place by cross pieces 17 which are themselves locked in place by nuts 18 engaging threaded rods which pass through the cross pieces. The cutters may be adjusted laterally by set screws 19 in the carriages which engage the edges of the cutters.

It will be apparent from what has already been said that my novel machine while adapted to use a single cutter is especially adapted to use a set of cutters, that is, a cutter on each side of the roll one acting to cut up and the other to cut down. In practice however, I preferably use more than one set of cutters. I have not illustrated this use of

the machine in the drawings as it is obviously unnecessary but shall presently refer to this use again.

Another important feature of my invention is the feed which I will now describe.

20 denotes a shaft journaled in bearings 21 and extending longitudinally of the machine. Oscillatory motion is imparted to this shaft in any ordinary or preferred manner. No means being shown in the drawings as such mechanism forms no portion of my present invention.

22 denotes a crank arm on shaft 20 by which movement is imparted to the feeding mechanism. When an additional set of cutters is used an additional crank arm is placed upon shaft 20 to actuate the feeding mechanism therefor.

23 denotes the feed shaft which is journaled in bearings 24 upon the carriage. This shaft is provided at one end with a gear wheel 25, at its mid-length with a worm 26 and at its opposite end with a bevel pinion 27. The novel feature of this portion of my invention lies in journaling shaft 23 in a plane oblique to the bed as is clearly shown in Fig. 4, the obliquity of the shaft being just sufficient to place the thread of the worm at right angles to the bed so that the worm will engage a gear wheel 28 journaled on and having longitudinal movement on a shaft 29 which extends outward from the carriage. This gear wheel is engaged by two gear wheels 30 having internally threaded hubs 31 which engage threaded shafts 32 extending outward from the carriage. The inner faces of hubs 31 bear upon a cross piece 33 through which both threaded shafts pass freely, that is to say the cross piece is provided with openings larger than the diameter of the threaded shafts so that there is no engagement between them.

Hubs 31 act as gear wheels 30 are moved inward on the threaded shafts, to force the cross piece forward, said cross piece engaging the outer end of cutter 11 and forcing it forward. The outer ends of shafts 29 and 32 are strengthened and supported by an angle brace 34.

I have for convenience used the singular form in describing the feeding mechanism. It will of course be understood however, that the feeding mechanisms upon each pair of carriages are counterparts of each other.

35 denotes a transverse shaft journaled in bearings 36 on the respective carriages. Adjustably secured at each end of this shaft but facing of course in opposite directions are bevel pinions 37, one of which receives motion from the driving feed shaft 23, the other communicating motion to the driven feed shaft on the other carriage. Each end of shaft 35 is squared as at 38 to receive a hand crank which may be applied whenever a hand feed is desired.

39 is a hub journaled on the driving feed shaft 23 and provided with an arm 40 carrying a pawl 41 which engages gear wheel 25.

42 is a connecting rod one end of which is pivoted to arm 40 the other to crank arm 22 on shaft 20. It will be seen therefore that oscillation of shaft 20 will oscillate hub 39 and arm 40 on the feed shaft and that the movement in one direction will move the pawl backward over the teeth of gear wheel 25, and that movement in the opposite direction will cause the pawl to engage gear wheel 25 and impart an axial movement to the feed shaft which in use through the engagement of the hubs of the opposite gear wheels 30 with cross pieces 33 will move the respective cutters inward a pre-determined distance depending of course upon the adjustment of the parts.

In use where two sets of cutters are used the carriages carrying one set of cutters are placed at one end of the roll and the carriages carrying the other set of cutters at the mid-length of the roll, the same relative arrangement being followed should it be preferred to use three carriages and three sets of cutters. As soon as the cuts upon the roll have been made to the proper depth, which is determined by calipering in the ordinary manner or if preferred by special mechanism, the tables with the carriages upon them are moved into position to make another cut and secured there in the manner described, the carriages themselves are adjusted upon the tables and secured there and the strengthening rods are placed in position as already described. The operation of making a cut may then proceed as before.

Having thus described my invention, I claim—

1. In a machine of the character described the combination with a carriage, a cutter thereon, and a shaft 29 and threaded shafts 32 extending outward from the carriage, of a cross piece against which the cutter rests and through which the threaded shafts pass without engagement, a gear wheel 28 journaled on shaft 29, gear wheels 30 engaging gear wheel 28 and having internally threaded hubs engaging threaded shafts 32 and bearing upon the cross piece and a feed shaft 23 having a worm and journaled obliquely so that the thread of the worm will engage the teeth of gear wheel 28, whereby the cutter is fed forward in use.

2. The combination with a carriage, a cutter thereon and a shaft 29 and threaded shafts 32 extending outward therefrom, of a cross piece against which the cutter rests and through which the threaded shafts pass without engagement, a gear wheel 28 journaled on shaft 29, gear wheels 30 engaging gear wheel 28 and having internally threaded hubs engaging the threaded shafts and bearing upon the cross piece, a feed shaft 23 having a worm and a gear wheel 25 said shaft being journaled obliquely so that the thread of the worm will engage gear wheel 28, a hub 39 journaled on the feed shaft and having an arm 40, a pawl carried by said arm and engaging gear

wheel 25, rock shaft 20 having arm 22 and a rod 42 connecting arms 22 and 40.

3. The combination with a table, carriages adapted to be moved in or out thereon, cutters on said carriages adapted to cut on opposite sides of a roll, and shafts 29 and threaded shafts 32 extending outward from the carriages, of cross pieces against which the cutters rest and through which the threaded shafts pass without engagement, gear wheels 28 journaled on shafts 29, gear wheels 30 engaging gear wheels 28 and having internally threaded hubs engaging the threaded shafts and bearing upon the cross pieces, feed shafts 23 having bevel pinions 27 provided with worms and journaled obliquely so that the threads of the worms will engage the teeth of gear wheels 28, one of said feed shafts having a gear wheel 25, an oscillating arm carrying a pawl engaging the gear wheel whereby motion is communicated, and a

transverse shaft 35 having bevel pinions engaging bevel pinions 27 whereby motion is communicated from one feed shaft to the other so that both cutters are fed inward uniformly. 25

4. In a machine of the character described, the combination with a bed, a movable table and two carriages on said table, of a feed shaft on each carriage provided with a worm and a bevel gear 27 and journaled obliquely so that the threads of the worms are at right angles to the machine, a transverse shaft having bevel gears engaging gears 27 and suitable mechanism operating in connection with the feed shafts to move the carriages inward or outward simultaneously. 35

In testimony whereof I affix my signature in presence of two witnesses.

GEORGE VINE.

Witnesses:

A. M. WOOSTER,  
SUSIE V. RICHARDSON.