

(19)
(12)

(KR)
(A)

(51) 。 Int. Cl.7
G02B 6/36

(11)
(43)

10-2004-0020249
2004 03 09

(21) 10-2002-0051788
(22) 2002 08 30

(71) 831

(72) 831

831

101 1609

831

831

831

1

(74)

:

(54)

가 V

가

, V

가

1					
2					
3	2				
4	2				
5	2				
6	2	1			
7	2	2	2		
8					
9a	9b				

* *
 110 : 120,130 : 1,2
 141,145 : 1,2 151,155 : 1,2
 160 : 170 : UV
 180 :

가 V
 가 가
 DWDM(Dense Wavelength Dvission Multiplexing :)
 . DWDM
 , Splitter, DWDM

DWDM (Fiber-Array)가 ,

1 ,
 , V (11a) V (11) UV(Ultraviolet) ()
 13) V (11a) , V (11a) (15) , V
 (11) (17) , (17) 가 (13)
 , UV (13) (13) V (11) (17)
 , (10)가 .

; , , 1 ; ; 1 1
 ; 1 ; 1 가 V 1 1 ; , ,
 2 ; 2 가 ; 2 ; 1 2 가 2 ; , ,
 1 2 ; 2 가 가 V 가 V
 ; 2 ; 2 ; 1 2 가 V
 ; 2 ; 1 2 V
 UV(Ultraviolet) V
 UV
 ,
 (10)
 2
 , (100) (110) (113) (110)
 15) 2 (115) 가 (113) 1 (Stage Part)(120)가 (110) (1
 (130)가 .
 1 (120) (121) (123)
 (125) (127) 가 , 2 (130) (131)
 (135) 가 (121,123,125,127,135)
 (131) (133) (131)
 (135)
 1 (120) (127) 1 (141) , 1
 (141) (115) (115) , 1 (141) 1
 (120) , , (130) (135) 2
 (130) 2 (160)가 , (160) (160)
 2 (145)가 1 (141)
 1 2 (141,145) 1 2 (151,155)가 가 , 1 2
 (151,155) V (11) (17)(6)가 , 2 (145) (180)(
 7)가 가 2 (145) , 2 (180) V (11)
 (17) . 1 2 (141,145), 1 2 (151,155),
 (180)
 (115) 1 (151) UV(Ultraviolet) (170)가 UV
 (170) V (11) (13) UV(Ultraviolet) UV

(151) 2 (156) 2 (155) (17) 2 (155) 2
 (157)가 (17)가 2 (156) (17)
 () 가 (17)가 2 (155) (17)
 1 (151) 2 (155) V (11) (17) 2 (153,157)
 1 2 (151,155) V (11) (17) 1 2 (153,157)
 V (11) (17)
 8
 (180) 2 (145a) 2 (145a) (180)
 2 (145a) (180)가 2 (180)가 2 (181) (1)
 45) (180)가 (17) (180) (17) (17) (17) (17) (17)
 (181) (17) (17) (17) (17) (17) (17) (180)
 9b 9a 9b 2
 (S110) 1 (120) 1 (141)
 1 (151) 1 (152) V (145) 1 (145a) (S120)
 1 (151) , V (11) UV (13) V (11) (1)
 15)
 (S130) 2 (145) 2 (145a) 2 (155) 2 (155)
 2 (156) (17) (130) V (11) (17) 2 (155)
 , 2 (155) (17)가 V (17) (17)가
 (S140) 2 (130) 2 (155) 2 (145)
 (S150) (180) 2 (145) 2 (145a) (S160)
 2 (130) (180) (181) (17) UV (170)
 UV , 40mW/cm² 400~600sec 가
 2 (130) (135) 2 (155) (180)
 (17) 가 (160) (180)
 (17) 가

, V 가
 가 , 가
 가 , 가

(57)

1.
 ;

;
 , , 1 ;
 1 1 , , 1 ;
 1 가 V 1 ;
 2 ;
 1 2 2 ;
 2 ;
 가 2 V 가 가 1 2 ; 가
 2 가 2 V
 ;
 2 2
 ;
 1 V UV UV(Ultraviolet)
 2.
 1 ,
 1 1 2 2 , 1 2
 1 2 1 , 2
 2
 3.
 2 ,
 1 V 2 가 V 1 2
 ,
 1 2 1 1 2 2
 V 2 가 1 2 2 1
 4.
 2 ,
 2 2 ,
 2 가 ,

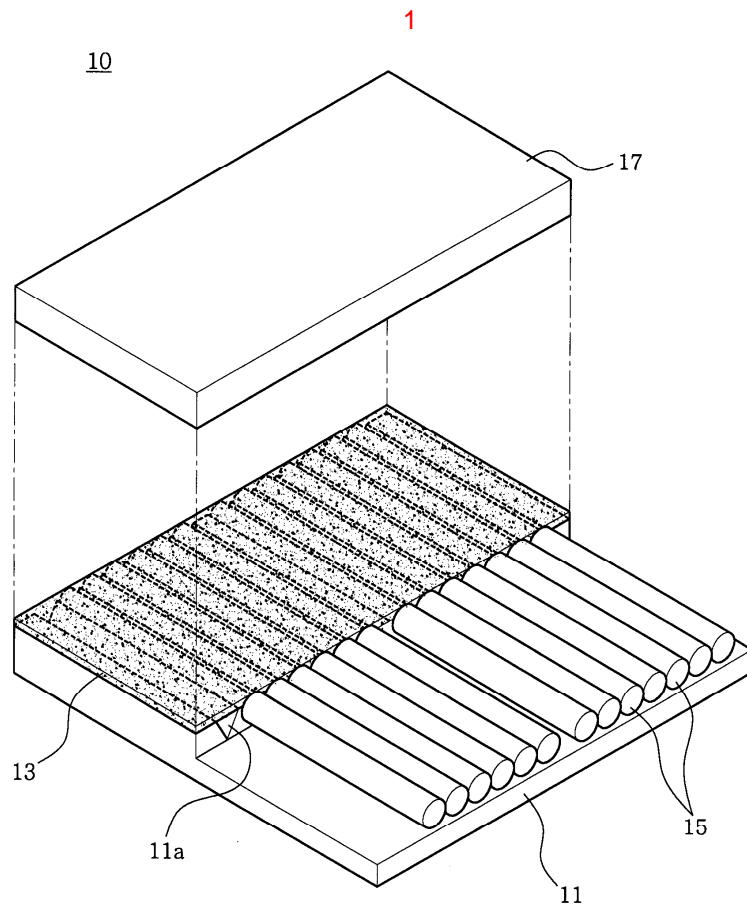

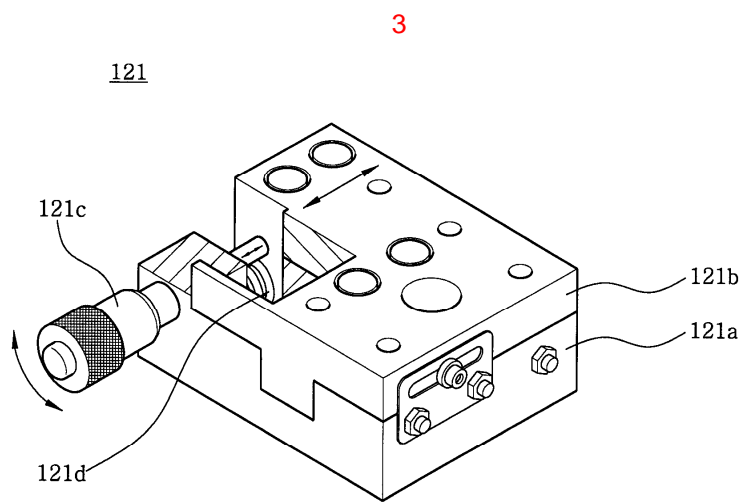
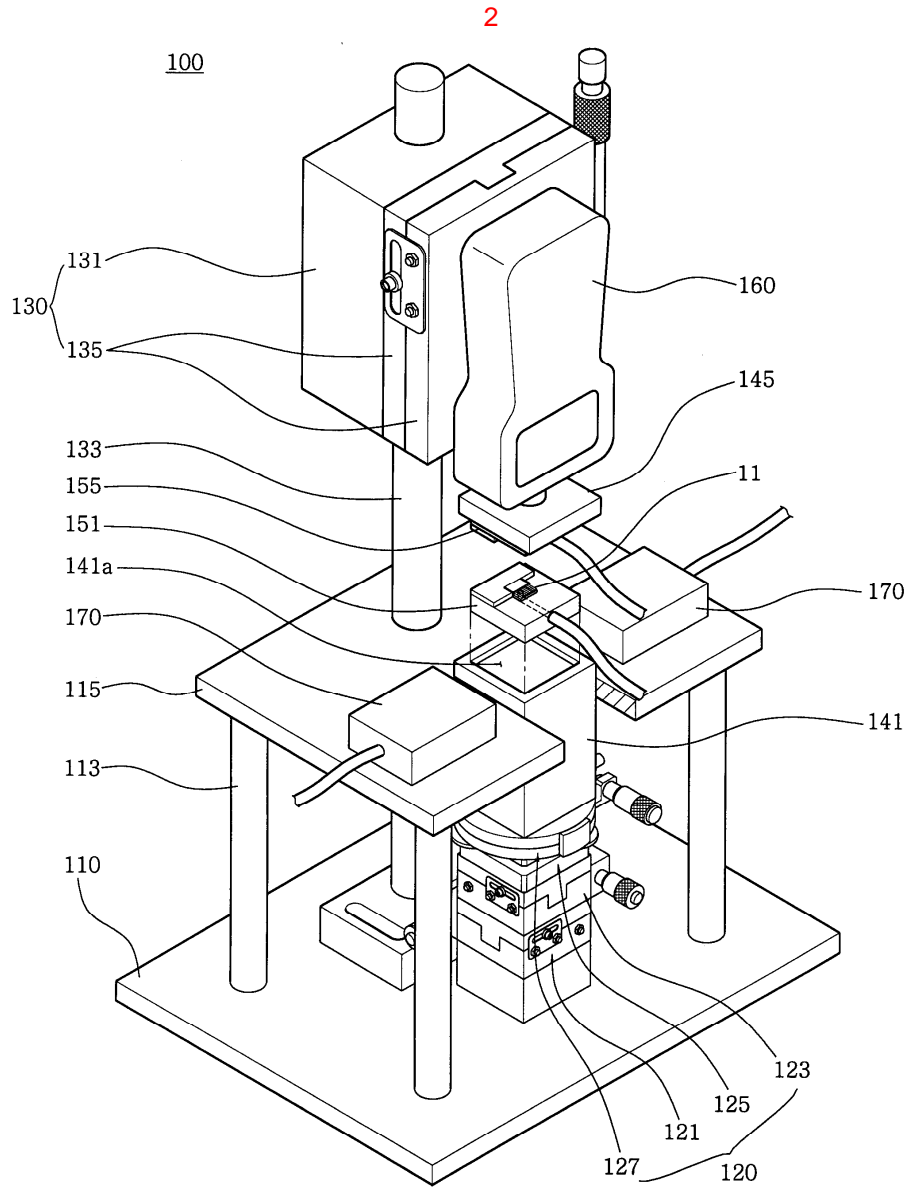

4

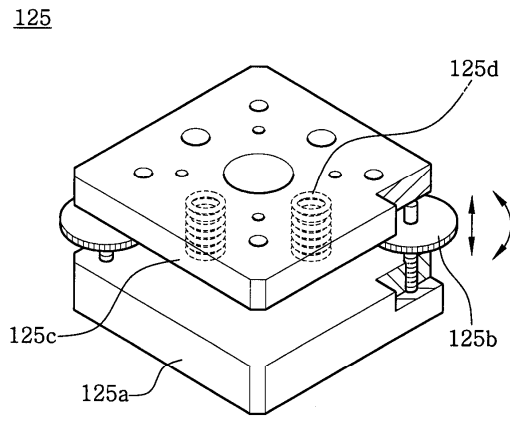

5

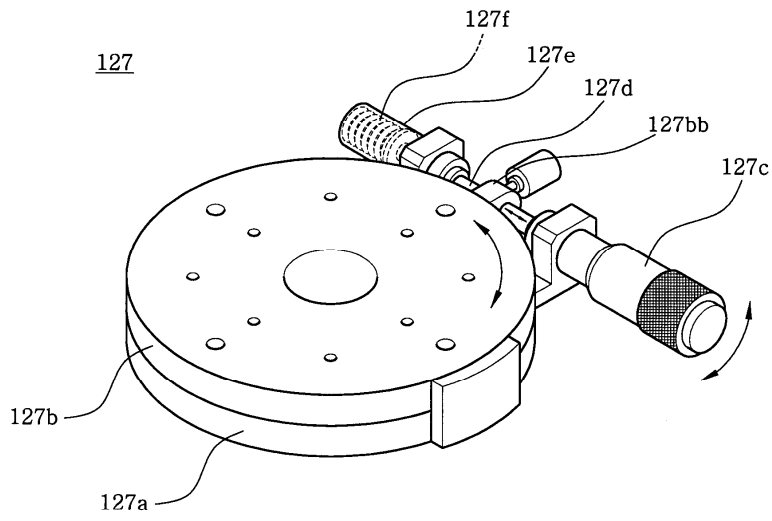

6

