



(51) International Patent Classification:

A61B 17/29 (2006.01) A61B 18/14 (2006.01)
A61B 17/32 (2006.01) A61B 19/00 (2006.01)

(21) International Application Number:

PCT/US2014/022449

(22) International Filing Date:

10 March 2014 (10.03.2014)

(25) Filing Language:

English

(26) Publication Language:

English

(30) Priority Data:

13/833,706 15 March 2013 (15.03.2013) US

(71) Applicant: **ETHICON ENDO-SURGERY, INC.**
[US/US]; 4545 Creek Road, Cincinnati, Ohio 45242 (US).

(72) Inventors: **PRICE, Daniel W.**; 185 Overlook Drive, Loveland, Ohio 45140 (US). **MESSERLY, Jeffrey D.**; 6757 Treeridge Drive, Cincinnati, Ohio 45244 (US). **MA-LAVIYA, Prasanna**; 5860 Maxfli Lane, Mason, Ohio 45040 (US). **BEETEL, Robert J., III**; 13438 Skyline Boulevard, Redwood City, California 94062 (US). **DIETZ, Timothy G.**; 428 West Avenue, Wayne, Pennsylvania 19087 (US). **WITT, David A.**; 1187 Chaucer Place, Maineville, Ohio 45039 (US). **TURNER, Douglas J.**; 3561 Centurion Drive, Cincinnati, Ohio 45211 (US). **NORVELL, David K.**; 570 Doverdale Drive, Monroe, Ohio 45050 (US). **RUPP, Kip M.**; 2096 State Route 232, New Richmond, Ohio 45147 (US). **WEED, John A., III**; 35 Ridge Wood Drive, Monroe, Ohio 45050 (US). **FELDER, Kevin D.**; 2460 Downing Drive, Cincinnati, Ohio

45208 (US). **HOUSER, Kevin L.**; 570 Foliage Lane, Springboro, Ohio 45066 (US). **FRANER, Paul T.**; 6217 Rapid Run Road, Cincinnati, Ohio 45233 (US). **FALLER, Craig N.**; 5960 E. Day Circle, Milford, Ohio 45150 (US). **DAVIS, Craig T.**; 3724 Morris Place, Cincinnati, Ohio 45226 (US).

(74) Agents: **JOHNSON, Philip S.** et al.; Johnson & Johnson, One Johnson & Johnson Plaza, New Brunswick, New Jersey 08933 (US).

(81) Designated States (unless otherwise indicated, for every kind of national protection available): AE, AG, AL, AM, AO, AT, AU, AZ, BA, BB, BG, BH, BN, BR, BW, BY, BZ, CA, CH, CL, CN, CO, CR, CU, CZ, DE, DK, DM, DO, DZ, EC, EE, EG, ES, FI, GB, GD, GE, GH, GM, GT, HN, HR, HU, ID, IL, IN, IR, IS, JP, KE, KG, KN, KP, KR, KZ, LA, LC, LK, LR, LS, LT, LU, LY, MA, MD, ME, MG, MK, MN, MW, MX, MY, MZ, NA, NG, NI, NO, NZ, OM, PA, PE, PG, PH, PL, PT, QA, RO, RS, RU, RW, SA, SC, SD, SE, SG, SK, SL, SM, ST, SV, SY, TH, TJ, TM, TN, TR, TT, TZ, UA, UG, US, UZ, VC, VN, ZA, ZM, ZW.

(84) Designated States (unless otherwise indicated, for every kind of regional protection available): ARIPO (BW, GH, GM, KE, LR, LS, MW, MZ, NA, RW, SD, SL, SZ, TZ, UG, ZM, ZW), Eurasian (AM, AZ, BY, KG, KZ, RU, TJ, TM), European (AL, AT, BE, BG, CH, CY, CZ, DE, DK, EE, ES, FI, FR, GB, GR, HR, HU, IE, IS, IT, LT, LU, LV, MC, MK, MT, NL, NO, PL, PT, RO, RS, SE, SI, SK, SM, TR), OAPI (BF, BJ, CF, CG, CI, CM, GA, GN, GQ, GW, KM, ML, MR, NE, SN, TD, TG).

[Continued on next page]

(54) Title: SURGICAL INSTRUMENT WITH MULTIPLE CLAMPING MECHANISMS

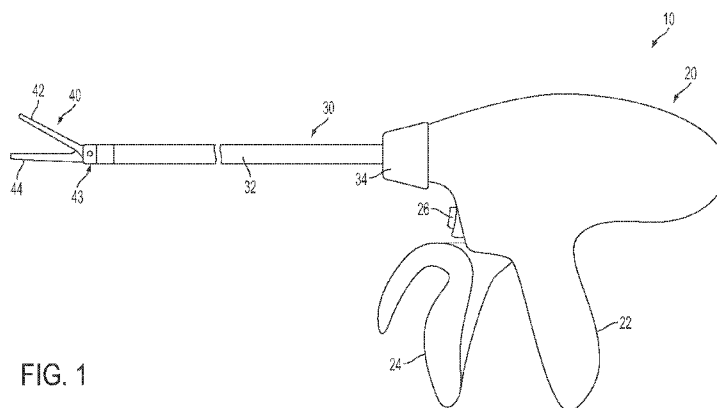

FIG. 1

(57) Abstract: A nested trigger assembly for a surgical instrument may generally comprise a first trigger and a second trigger, wherein the first trigger and the second trigger are movable together on a first stroke of the nested trigger assembly, wherein the second trigger is configured to be biased away from the first trigger after the first stroke and before a second stroke, and wherein the second trigger is configured to be moved toward to the first trigger during the second stroke. A surgical instrument may generally comprise a shaft comprising a proximal end and a distal end, a handle extending from the proximal end, wherein the handle comprises a gripping portion, and a nested trigger assembly extending from the handle. The nested trigger assembly may comprise one of a separable trigger assembly and a divisible trigger assembly.





Declarations under Rule 4.17:

- *as to the identity of the inventor (Rule 4.17(i))*
- *as to applicant's entitlement to apply for and be granted a patent (Rule 4.17(ii))*
- *as to the applicant's entitlement to claim the priority of the earlier application (Rule 4.17(iii))*

Published:

- *with international search report (Art. 21(3))*
- *before the expiration of the time limit for amending the claims and to be republished in the event of receipt of amendments (Rule 48.2(h))*

TITLE

SURGICAL INSTRUMENT WITH MULTIPLE CLAMPING MECHANISMS

BACKGROUND

1. Field of the Invention

[0001] The present application generally relates to medical devices and methods, and in particular, surgical instruments configured to weld and/or incise tissue.

2. Description of the Related Art

[0002] In various circumstances, a surgical instrument can be configured to apply energy to tissue in order to treat and/or destroy the tissue. In certain circumstances, a surgical instrument can comprise one or more electrodes which can be positioned against and/or positioned relative to the tissue such that electrical current can flow through the electrodes and into the tissue. The surgical instrument can further comprise an electrical input, a supply conductor electrically coupled with the electrodes, and/or a return conductor which can be configured to allow current to flow from the electrical input, through the supply conductor, through the electrodes and tissue, and then through the return conductor to an electrical output, for example. In various circumstances, the energy can generate heat within the captured tissue to create one or more hemostatic seals within the tissue. Such embodiments may be particularly useful for sealing blood vessels, for example. The surgical instrument can comprise an ultrasonic blade, connected to an ultrasonic transducer, to couple mechanical vibration to tissue and create one or more hemostatic seals and divide the tissue simultaneously. Such embodiments may be particularly useful for sealing and dividing blood vessels, for example. Furthermore, other energy modalities may be contemplated, but not limited to, microwave, laser, thermal, and high intensity focused ultrasound. The surgical instrument can further comprise a cutting member which can be moved relative to the tissue and electrodes in order to transect the tissue.

[0003] The foregoing discussion is intended only to illustrate various aspects of the related art in the field of the invention at the time, and should not be taken as a disavowal of claim scope.

SUMMARY

[0004] In various embodiments, a surgical instrument may generally comprise a shaft comprising a proximal end and a distal end; an end effector extending from the distal end of the

shaft, wherein the end effector is operable to grasp tissue; a handle extending from the proximal end, wherein the handle comprises a gripping portion; and a trigger assembly extending from the handle, wherein the trigger assembly comprises a trigger movable relative to the gripping portion between an unactuated position and a first actuated position and a second actuated position, wherein the trigger is operable to control the end effector to selectively grasp tissue at a first compressive force when the trigger is in the first actuated position and a second compressive force when the trigger is in the second actuated position.

[0005] In various embodiments, a surgical instrument may generally comprise a shaft comprising a proximal end and a distal end; an end effector extending from the distal end of the shaft, wherein the end effector comprises a first jaw, a second jaw, and an electrode, wherein the first jaw is movable relative to the second jaw between an open position and a closed position to compress tissue intermediate the first jaw and second jaw when in the closed position; a handle extending from the proximal end, wherein the handle comprises a gripping portion; and a trigger assembly extending from the handle, wherein the trigger assembly comprises a trigger movable relative to the gripping portion through a first range of motion from an unactuated position to a first actuated position, wherein the trigger is movable through a second range of motion from first actuated position to a second actuated position, and wherein the trigger is movable through a third range of motion from the second actuated position to the unactuated position, wherein the trigger is operable to control the end effector to selectively compress tissue at a first compressive force when the trigger is in the first actuated position and a second compressive force when the trigger is in the second actuated position, wherein the first compressive force is greater than the second compressive force.

[0006] In various embodiments, a surgical instrument may generally comprise a shaft comprising a proximal end and a distal end; an ultrasonic waveguide at least partially positioned within the shaft, the waveguide having a proximal end and a distal end; an ultrasonically actuated blade positioned at the distal end of the waveguide; a clamp arm assembly pivotally connected to the distal end of the shaft, wherein the clamp arm assembly comprises at least two camming members rotationally attached to a clamp arm, wherein the clamp arm is movable between an open position and a closed position relative to the blade to compress tissue intermediate the clamp arm and blade when in the closed position, and wherein the at least two camming

members rotate relative to the clamp arm to separate tissue layers when the clamp arm moves between the open position and a closed position.

BRIEF DESCRIPTION OF THE FIGURES

[0007] Various features of the embodiments described herein are set forth with particularity in the appended claims. The various embodiments, however, both as to organization and methods of operation, together with advantages thereof, may be understood in accordance with the following description taken in conjunction with the accompanying drawings as follows.

[0008] FIG. 1 includes a side elevational view of a surgical instrument according to various embodiments.

[0009] FIG. 2 includes a perspective view of the end effector of the device of FIG. 1, in an open configuration according to various embodiments.

[0010] FIG. 3 includes another perspective view of the end effector of the device of FIG. 1, in an open configuration according to various embodiments.

[0011] FIG. 4 includes a cross-sectional end view of the end effector of FIG. 2, in a closed configuration and with the blade in a distal position according to various embodiments.

[0012] FIG. 4A includes a surgical instrument comprising an end effector comprising roller bearings according to various embodiments.

[0013] FIG. 5 includes a surgical instrument comprising a trigger assembly in various positions according to various embodiments.

[0014] FIG. 6 includes a surgical instrument comprising a trigger bypass mechanism according to various embodiments.

[0015] FIG. 7 includes the trigger bypass mechanism illustrated in FIG. 6.

[0016] FIGS. 8A-G include a surgical instrument comprising a trigger assembly in various positions according to various embodiments.

[0017] FIGS. 9A-G include a surgical instrument comprising a trigger assembly in various positions according to various embodiments.

[0018] FIGS. 10A-D include a surgical instrument comprising a trigger assembly in various positions according to various embodiments.

[0019] FIGS. 11A-C include a surgical instrument comprising a trigger assembly in various positions according to various embodiments.

[0020] FIG. 12 includes a cross sectional view of a rear yoke pin path in a surgical instrument according to various embodiments

[0021] FIG. 13 includes a cross sectional view of a rear yoke pin path in a surgical instrument according to various embodiments

[0022] FIGS. 14A-C include a surgical instrument comprising a trigger assembly in various positions according to various embodiments.

[0023] FIGS. 15A-K include a surgical instrument comprising a trigger assembly in various positions according to various embodiments.

[0024] FIG. 16 includes a surgical instrument comprising a trigger assembly according to various embodiments.

[0025] FIGS. 17A-H include cross-sectional views of a portion of a vessel subjected to a compressive force according to various embodiments.

[0026] FIGS. 18A and 18B include a surgical instrument comprising an end effector in various positions according to various embodiments.

[0027] FIGS. 19A and 19B include a side elevational view of the handle assembly of a surgical instrument with a housing half removed according to various embodiments.

[0028] FIG. 20 includes an end effector comprising rotational features according to various embodiments.

[0029] FIGS. 21A and 21B includes a camming member comprising a protrusion according to various embodiments

[0030] Corresponding reference characters indicate corresponding parts throughout the several views. The exemplifications set out herein illustrate various embodiments of the invention, in one form, and such exemplifications are not to be construed as limiting the scope of the invention in any manner.

DETAILED DESCRIPTION

[0031] Various embodiments are directed to apparatuses, systems, and methods for the treatment of tissue. Numerous specific details are set forth to provide a thorough understanding of the overall structure, function, manufacture, and use of the embodiments as described in the specification and illustrated in the accompanying drawings. It will be understood by those skilled in the art, however, that the embodiments may be practiced without such specific details.

In other instances, well-known operations, components, and elements have not been described in detail so as not to obscure the embodiments described in the specification. Those of ordinary skill in the art will understand that the embodiments described and illustrated herein are non-limiting examples, and thus it can be appreciated that the specific structural and functional details disclosed herein may be representative and do not necessarily limit the scope of the embodiments, the scope of which is defined solely by the appended claims.

[0032] Reference throughout the specification to “various embodiments,” “some embodiments,” “one embodiment,” or “an embodiment”, or the like, means that a particular feature, structure, or characteristic described in connection with the embodiment is included in at least one embodiment. Thus, appearances of the phrases “in various embodiments,” “in some embodiments,” “in one embodiment,” or “in an embodiment”, or the like, in places throughout the specification are not necessarily all referring to the same embodiment. Furthermore, the particular features, structures, or characteristics may be combined in any suitable manner in one or more embodiments. Thus, the particular features, structures, or characteristics illustrated or described in connection with one embodiment may be combined, in whole or in part, with the features structures, or characteristics of one or more other embodiments without limitation.

[0033] It will be appreciated that the terms “proximal” and “distal” may be used throughout the specification with reference to a clinician manipulating one end of an instrument used to treat a patient. The term “proximal” refers to the portion of the instrument closest to the clinician and the term “distal” refers to the portion located furthest from the clinician. It will be further appreciated that for conciseness and clarity, spatial terms such as “vertical,” “horizontal,” “up,” and “down” may be used herein with respect to the illustrated embodiments. However, surgical instruments may be used in many orientations and positions, and these terms are not intended to be limiting and absolute.

[0034] Various embodiments of systems and methods relate to creating thermal “welds” or “fusion” within native tissue volumes. The alternative terms of tissue “welding” and tissue “fusion” may be used interchangeably herein to describe thermal treatments of a targeted tissue volume that result in a substantially uniform fused-together tissue mass, for example, in welding blood vessels that exhibit substantial burst strength immediately post-treatment. The strength of such welds is particularly useful for (i) permanently sealing blood vessels in vessel transection procedures; (ii) welding organ margins in resection procedures; (iii) welding other anatomic

ducts wherein permanent closure is required; and also (iv) for performing vessel anastomosis, vessel closure or other procedures that join together anatomic structures or portions thereof. The welding or fusion of tissue as disclosed herein is to be distinguished from “coagulation”, “hemostasis” and other similar descriptive terms that generally relate to the collapse and occlusion of blood flow within small blood vessels or vascularized tissue. For example, any surface application of thermal energy can cause coagulation or hemostasis-but does not fall into the category of “welding” as the term is used herein. Such surface coagulation does not create a weld that provides any substantial strength in the treated tissue.

[0035] At the molecular level, the phenomena of truly “welding” tissue as disclosed herein may result from the thermally-induced denaturation of collagen and other protein molecules in a targeted tissue volume to create a transient liquid or gel-like proteinaceous amalgam. A selected energy density is provided in the targeted tissue to cause hydrothermal breakdown of intra- and intermolecular hydrogen crosslinks in collagen and other proteins. The denatured amalgam is maintained at a selected level of hydration-without desiccation-for a selected time interval which can be very brief. The targeted tissue volume is maintained under a selected very high level of mechanical compression to insure that the unwound strands of the denatured proteins are in close proximity to allow their intertwining and entanglement. Upon thermal relaxation, the intermixed amalgam results in protein entanglement as re-crosslinking or renaturation occurs to thereby cause a uniform fused-together mass.

[0036] Ultrasonic surgical instruments are finding increasingly widespread applications in surgical procedures by virtue of the unique performance characteristics of such instruments. Depending upon specific instrument configurations and operational parameters, ultrasonic surgical instruments can provide substantially simultaneous cutting of tissue and hemostasis by coagulation, desirably minimizing patient trauma. The cutting action is typically effected by an end effector or blade tip at the distal end of the instrument, which transmits ultrasonic energy to tissue brought into contact with the end effector. Ultrasonic instruments of this nature can be configured for open surgical use, laparoscopic or endoscopic surgical procedures including robotic-assisted procedures.

[0037] Ultrasonic surgical instruments have been developed that include a clamp mechanism to press tissue against the blade of the end effector in order to couple ultrasonic energy to the tissue of a patient. Such an arrangement (sometimes referred to as a clamp coagulator shears or an

ultrasonic transector) is disclosed in U.S. Pat. Nos. 5,322,055, 5,873,873, and 6,325,811, all of which are incorporated herein by reference in their entireties. The surgeon activates the clamp arm to press the clamp pad against the blade by squeezing on the handgrip or handle.

[0038] Some current ultrasonic shears devices utilize tissue engaging pads or clamp pads that close in parallel with the surface of the blade. By this construction, tissue is grasped between the clamp pad and the blade. The clamp pad may comprise a low coefficient of friction polymer material, or any other suitable low-friction material. Although these designs have been adequate, they tend to suffer from longevity issues since the clamp pads tend to deteriorate over long surgical procedures. Additionally, newer designs of clamp coagulator shears increase blade amplitude and/or the loading of the clamp pad against the tissue and blade and overwhelm the clamp pad material, resulting in less than required clamp pad life. The clamp pad material limits the amount of force that may be applied against the tissue and blade, which in turn limits the tissue thickness or vessel size that some current clamp coagulator shears may effectively cut and coagulate.

[0039] It would be desirable to provide electrosurgical instruments that overcome some of the deficiencies of current ultrasonic surgical instruments. Various embodiments of the electrosurgical instruments described herein may overcome some of those deficiencies.

[0040] Enhancing the ability to seal vessels may be accomplished by placing the adventitial layers of the opposing sides of a coapted vessel in direct contact with each other. Preventing this direct contact is commonly the muscular (intima) layer of the vessel. The muscular layers may be "split" within a vessel without compromising the adventitia by applying a sufficient compressive force. The muscular layers may retract enough to allow direct adventitial contact. The direct adventitial seals demonstrate higher burst pressures. In various embodiments, an electrosurgical device may provide variable force control to allow the user to create a large compressive force for muscle separation and a smaller compressive force for application of ultrasonic energy and sealing and cutting.

[0041] In various embodiments, electrosurgical instruments may be configured to provide multiple trigger positions to deliver multiple levels of compressive force to the tissue. The compressive force may be generally established by a handle using one of two user-selectable clamping modes to provide variable force control: one for cutting and coagulating small blood vessels; and one for cutting and coagulating large blood vessels. The large vessel coagulating

mode generally corresponds to a sequence where the end effector delivers a short-term high compressive force and then progresses to a position of lesser compressive force. For example, in various embodiments, the lesser compressive force may be about 50% to about 70% of the high compressive force. The high compressive force may compress a large vessel such that the inner layers of the vessel, i.e., the tunica intima and tunica media, are extruded and separated and only the outer layer of the vessel, i.e., the tunica adventitia, resides within the end effector.

[0042] Without wishing to be bound to any particular theory, it is believed that the adventitia contributes most significantly to the seal strength of an ultrasonically transected vessel, and the inner layers of the vessel contribute very little to the seal strength and, in fact, tend to flatten and structurally counteract the adventitia seal. Accordingly, electro-surgical instruments may be configured to provide a high compressive force to mechanically extrude the inner layers of the vessel and a low compressive force to allow direct adventitial contact and an adventitia-to-adventitia seal. Various embodiments of electro-surgical instruments described herein may provide certain advantages over current ultrasonic shears devices, including one or more of the following: obtaining a seal at a more manageable, lower clamping force; obtaining a seal at a lower generator drive power; lower generator power requirements; utilizing less durable clamp pad materials; improved large vessel sealing; improved clamp pad life; improved ergonomics by only using the high clamp force, which corresponds to high input force, when required; improved efficiency; and improved cost savings.

[0043] An electro-surgical instruments can be configured to supply energy, such as electrical energy, ultrasonic energy, and/or heat energy, for example, to the tissue of a patient. For example, various embodiments disclosed herein provide electro-surgical jaw structures adapted for transecting captured tissue between the jaws and for contemporaneously welding or sealing the captured tissue margins with controlled application of RF energy. In various embodiments, the electro-surgical jaw structures may be adapted to coagulate the captured tissues rather than weld the captured tissue. Electro-surgical instruments may also be configured to, for example, grasp, sever, and staple tissue. Electro-surgical instruments may be configured to supply other energy modalities and/or combinations thereof, such as, for example, microwave, laser, thermal, ultrasonic and high intensity focused ultrasound. All such arrangements and implementations are intended to be within the scope of this disclosure.

[0044] In various embodiments, referring to FIG. 1, an electrosurgical instrument 10 may comprise a hand piece 20, a shaft 30 extending distally from hand piece 20, and an end effector 40 disposed at a distal end of shaft 30. Hand piece 20 may comprise a pistol grip 22, a pivoting trigger 24, and an activation button 26. Trigger 24 may be pivotable toward and away from pistol grip 22 to selectively actuate end effector 40 as will be described in greater detail below. Activation button 26 may be operable to selectively activate RF circuitry that is in communication with end effector 40, as will also be described in greater detail below. In some versions, activation button 26 may also serve as a mechanical lockout against trigger 24, such that trigger 24 cannot be fully actuated unless button 26 is being pressed simultaneously. Examples of how such a lockout may be provided are disclosed in one or more of the references cited herein. It should be understood that pistol grip 22, trigger 24, and button 26 may be modified, substituted, supplemented, etc. in any suitable way, and that the descriptions of such components herein are merely illustrative.

[0045] Shaft 30 may comprise any suitable cross-section, such as, for example, a cylindrical cross-section and/or rectangular cross-section. Shaft 30 may comprise an outer sheath 32 that extends from the hand piece 20. A proximal end of shaft 30 may be attached to the hand piece 20. In various embodiments, shaft 30 may be rotatable about the longitudinal axis defined by sheath 32, relative to hand piece 20 via a knob 34. Such rotation may provide rotation of end effector 40 and shaft 30 unitarily. In various embodiments, knob 34 may be operable to rotate end effector 40 without rotating any portion of shaft 30.

[0046] In various embodiments, end effector 40 may comprise a first jaw 42 and a second jaw 44. Second jaw 44 may be substantially fixed relative to shaft 30; while first jaw 42 may pivot relative to shaft 30, toward and away from second jaw 44. In various embodiments, actuators, such as, for example, rods and cables, may extend through sheath 32 and be joined with first jaw 42 at a pivotal coupling 43 such that longitudinal movement of the actuator through shaft 30 provides pivoting of first jaw 42 relative to shaft 30 and relative to second jaw 44. In various embodiments, jaws 42, 44 may comprise any other suitable kind of movement and may be actuated in any other suitable fashion. For example, as will be described in greater detail below, jaws 42, 44 may be actuated and thus closed by longitudinal translation of a firing beam 60 such that actuators may simply be eliminated in certain embodiments.

[0047] In various embodiments, referring to FIGS. 2-4, first jaw 42 defines a longitudinally extending elongate slot 46 and second jaw 44 defines a longitudinally extending elongate slot 48. The top side of first jaw 42 may comprise a first electrode surface 50 and the underside of second jaw 44 may comprise a second electrode surface 52. Electrode surfaces 50, 52 may be in communication with an electrical source 80 via one or more conductors (not shown) that extend along the length of shaft 30. Electrical source 80 may be operable to deliver RF energy to first electrode surface 50 at a first polarity and to second electrode surface 52 at a second (opposite) polarity, such that RF current flows between electrode surfaces 50, 52 and thereby through tissue captured between jaws 42, 44. In various embodiments, firing beam 60 may serve as an electrical conductor that cooperates with electrode surfaces 50, 52, e.g., as a ground return for delivery of bipolar RF energy captured between jaws 42, 44. Electrical source 80 may be external to electrosurgical instrument 10 or may be integral with electrosurgical instrument 10, e.g., in hand piece 20. A controller 82 may regulate delivery of power from electrical source 80 to electrode surfaces 50, 52. Controller 82 may be external to electrosurgical instrument 10 or may be integral with electrosurgical instrument 10, e.g., in hand piece 20. It should also be understood that electrode surfaces 50, 52 may be provided in a variety of alternative locations, configurations, and relationships.

[0048] Referring to FIG. 4, the lower side of first jaw 42 may comprise a longitudinally extending recess 58 adjacent to slot 46 and the upper side of second jaw 44 may comprise a longitudinally extending recess 58 adjacent to slot 48. FIG. 2 shows the upper side of first jaw 42 including a plurality of teeth serrations 46. It should be understood that the lower side of second jaw 44 may include complementary serrations that nest with serrations 46 to enhance gripping of tissue captured between jaws 42, 44 without necessarily tearing the tissue. FIG. 3 shows an example of serrations 46 in first jaw 42 as mainly recesses; with serrations 48 in second jaw 44 as mainly protrusions. Of course, serrations 46, 48 may take any other suitable form or may be simply omitted altogether. It should also be understood that serrations 46, 48 may be formed of an electrically non-conductive, or insulative, material, such as plastic, glass, and/or ceramic, for example, and may include a treatment such as polytetrafluoroethylene, a lubricant, or some other treatment to substantially prevent tissue from getting stuck to jaws 42, 44.

[0049] When jaws 42, 44 are in a closed position, shaft 30 and end effector 40 may be sized and configured to fit through trocars having various inner diameters, such that electrosurgical instrument 10 may be usable in minimally invasive surgery, though of course electrosurgical instrument 10 could also be used in open and endoscopic procedures if desired. By way of example only, shaft 30 and end effector 40 may present an outer diameter of approximately 5 mm when jaws 42, 44 are in a closed position. Alternatively, shaft 30 and end effector 40 may present any other suitable outer diameter, such as, for example, from about 2 mm to about 20 mm.

[0050] In various embodiments, either jaw 42, 44 or both of jaws 42, 44 may include at least one port, passageway, conduit, and/or other feature that is operable to draw steam, smoke, and/or other gases from the surgical site. Such a feature may be in communication with a source of suction, such as, for example, an external source or a source within hand piece 20. In addition, end effector 40 may comprise one or more tissue cooling features (not shown) that reduce the degree or extent of thermal spread caused by end effector 40 on adjacent tissue when electrode surfaces 50, 52 are activated. Various suitable forms that such cooling features may take will be apparent to those of ordinary skill in the art in view of the teachings herein.

[0051] In various embodiments, end effector 40 may comprise one or more sensors (not shown) that are configured to sense a variety of parameters at end effector 40, including but not limited to, jaw position, temperature of adjacent tissue, electrical resistance or impedance of adjacent tissue, voltage across adjacent tissue, forces exerted on jaws 42, 44 by adjacent tissue. In various embodiments, end effector 40 may include one or more positive temperature coefficient (PTC) thermistor bodies 54, 56, e.g., a PTC polymer, located adjacent to electrodes 50, 52 and/or elsewhere. Data from sensors may be communicated to controller 82. Controller 82 may process such data in a variety of ways. In various embodiments, controller 82 may modulate or otherwise change the RF energy being delivered to electrode surfaces 50, 52, based at least in part on data acquired from one or more sensors at end effector 40. In various embodiments, controller 82 may alert the user to one or more conditions via an audio and/or visual feedback device, e.g., speaker, lights, display screen, etc., based at least in part on data acquired from one or more sensors at end effector 40. It should also be understood that some kinds of sensors need not necessarily be in communication with controller 82, and may simply provide a purely localized effect at end effector 40. In various embodiments, PTC thermistor bodies 54, 56 at end

effector 40 may automatically reduce the energy delivery at electrode surfaces 50, 52 as the temperature of the tissue and/or end effector 40 increases, thereby reducing the likelihood of overheating. In various embodiments, a PTC thermistor element may be in series with power source 80 and electrode surface 50, 52; and the PTC thermistor may provide an increased impedance to reduce flow of current in response to temperatures exceeding a threshold. Furthermore, it should be understood that electrode surfaces 50, 52 may be used as sensors, e.g., to sense tissue impedance. Various kinds of sensors that may be incorporated into electrosurgical instrument 10 will be apparent to those of ordinary skill in the art in view of the teachings herein. Similarly various things that can be done with data from sensors, by controller 82 or otherwise, will be apparent to those of ordinary skill in the art in view of the teachings herein. Other suitable variations for end effector 40 will also be apparent to those of ordinary skill in the art in view of the teachings herein.

[0052] In various embodiments, referring to FIGS. 2-4, electrosurgical instrument may comprise a firing beam 60 that is longitudinally movable along part of the length of end effector 40. Firing beam 60 may be coaxially positioned within shaft 30, extends along the length of shaft 30, and translates longitudinally within shaft 30, though it should be understood that firing beam 60 and shaft 30 may have any other suitable relationship. Firing beam 60 may comprise a sharp distal blade 64, an upper flange 62, and a lower flange 66. As illustrated in FIG. 4, distal blade 64 extends through slots 46, 48 of jaws 42, 44, with upper flange 62 being located above jaw 44 in recess 59 and lower flange 66 being located below jaw 42 in recess 58. The configuration of distal blade 64 and flanges 62, 66 provides an "I-beam" type of cross section at the distal end of firing beam 60. In various embodiments, flanges 62, 66 may extend longitudinally along any suitable length of firing beam 60. In various embodiments, flanges 62, 66 may be positioned along the exterior of jaws 42, 44, or disposed in corresponding slots formed within jaws 42, 44. For example, each jaw 42, 44 may define a "T"-shaped slot, with portions of distal blade 64 being disposed in one vertical portion of each "T"-shaped slot and with flanges 62, 66 being disposed in the horizontal portions of the "T"-shaped slots. Referring to FIG. 4A, in various embodiments, distal blade 64 may comprise at least one roller bearing 38 to compress tissue T and/or fracture calcium formed within or externally to the vessel. Roller bearing 38 may comprise a conical cylinder have a decreasing diameter laterally away from distal blade 64, as shown in FIG. 4A. In various embodiments, roller bearing 38 may comprise a conical cylinder

have a increasing diameter laterally away from distal blade 64. In various embodiments, roller bearing 38 may comprise a straight cylinder. In various embodiments, roller bearing 38 may comprise a curved cross-sectional shape, such as, for example, a circle and an ellipse. As shown in FIG. 4A, roller bearings 38 may be positioned on opposing sides of distal blade 64 intermediate jaws 42, 44. In various embodiments, distal blade 64 may comprise a pin (not shown) to rotate roller bearing 38 relative to distal blade 64. In various embodiments, distal blade may comprise a vertical slot including a pin slideably disposed in the vertical slot to rotate roller bearing 38 and/or move roller bearing 38 perpendicularly relative to distal blade 64. Various other suitable configurations and relationships will be apparent to those of ordinary skill in the art in view of the teachings herein.

[0053] Distal blade 64 may be substantially sharp, such that distal blade 64 may readily sever tissue that is captured between jaws 42, 44. Distal blade 64 may be electrically grounded to provide a return path for RF energy as described elsewhere herein. In various embodiments, distal blade 64 may serve as an active electrode. In various embodiments, distal blade 64 may be selectively energized with ultrasonic energy, such as, for example, harmonic vibrations at about 55.5 kHz.

[0054] In various embodiments, the "I-beam" type of configuration of firing beam 60 may provide closure of jaws 42, 44 as firing beam 60 is advanced distally. In particular, flange 62 urges jaw 44 pivotally toward jaw 42 as firing beam 60 is advanced from a proximal position, as shown in FIGS. 1-3, to a distal position, as shown in FIG. 4, by bearing against recess 59 formed in jaw 44. This closing effect on jaws 42, 44 by firing beam 60 may occur before distal blade 64 reaches tissue captured between jaws 42, 44. Such staging of encounters by firing beam 60 may reduce the force required to squeeze grip 24 to actuate firing beam 60 through a full firing stroke. In other words, in various embodiments, firing beam 60 may have already overcome an initial resistance required to substantially close jaws 42, 44 on tissue before encountering resistance from severing the tissue captured between jaws 42, 44. Of course, any other suitable staging may be provided.

[0055] In various embodiments, flange 62 may be configured to cam against a ramp feature at the proximal end of jaw 44 to open jaw 42 when firing beam 60 is retracted to a proximal position and to hold jaw 42 open when firing beam 60 remains at the proximal position. This camming capability may facilitate use of end effector 40 to separate layers of tissue, to perform

blunt dissections, etc., by forcing jaws 42, 44 apart from a closed position. In various embodiments, jaws 42, 44 may be resiliently biased to an open position by a spring or other type of resilient feature. While jaws 42, 44 close or open as firing beam 60 is translated, it should be understood that other embodiments may provide independent movement of jaws 42, 44 and firing beam 60. In various embodiments, one or more cables, rods, beams, or other features may extend through shaft 30 to selectively actuate jaws 42, 44 independently of firing beam 60. Such jaw 42, 44 actuation features may be separately controlled by a dedicated feature of hand piece 20. In various embodiments, such jaw actuation features may be controlled by trigger 24 in addition to having trigger 24 control firing beam 60. It should also be understood that firing beam 60 may be resiliently biased to a proximal position, such that firing beam 60 retracts proximally when a user relaxes their grip on trigger 24.

[0056] In various embodiments, in use, end effector 40 may be inserted into a patient via a trocar to a desired position and orientation relative to an anatomical structure within the patient. Two layers of tissue of the anatomical structure are then captured between jaws 42, 44 by squeezing trigger 24 toward pistol grip 22. Such layers of tissue may be part of the same natural lumen defining anatomical structure, such as, for example, blood vessel, portion of gastrointestinal tract, portion of reproductive system, etc., in a patient. In various embodiments, one tissue layer may comprise the top portion of a blood vessel and the other tissue layer may comprise the bottom portion of the blood vessel, along the same region of length of the blood vessel. In various embodiments, the fluid path through the blood vessel before use of electro-surgical instrument 10 may be perpendicular to the longitudinal axis defined by end effector 40. The lengths of jaws 42, 44 may be oriented perpendicular to or at least generally transverse to the length of the blood vessel. As described above, flanges 62, 66 cammingly act to pivot jaw 44 toward jaw 42 when firing beam 60 is actuated distally by squeezing trigger 24 toward pistol grip 22.

[0057] In various embodiments, with tissue layers captured between jaws 42, 44, firing beam 60 may continue to advance distally by the user squeezing trigger 24 toward pistol grip 22. As firing beam 60 advances distally, distal blade 64 simultaneously severs the clamped tissue layers, resulting in separated upper layer portions being apposed with respective separated lower layer portions. This results in a blood vessel being cut in a direction that is generally transverse to the length of the blood vessel. It should be understood that the presence of flanges 62, 66

immediately above and below jaws 42, 44, respectively, may help keep jaws 42, 44 in a closed and tightly clamping position. In particular, flanges 62, 66 may help maintain a significantly compressive force between jaws 42, 44. With severed tissue layer portions being compressed between jaws 42, 44, electrode surfaces 50, 52 may be activated with bipolar RF energy by the user depressing activation button 26. In various embodiments, electrodes 50, 52 may be selectively coupled with power source 80, for example by the user depressing button 26, such that electrode surfaces 50, 52 of jaws 42, 44 are activated with a common first polarity while firing beam 60 is activated at a second polarity that is opposite to the first polarity. Thus, a bipolar RF current flows between firing beam 60 and electrode surfaces 50, 52 of jaws 42, 44 through the compressed regions of severed tissue layer portions. In various embodiments, electrode surface 50 has one polarity while electrode surface 52 and firing beam 60 both have the other polarity. Bipolar RF energy may be delivered by power source 80 to thermally weld the tissue layer portions on one side of firing beam 60 together and the tissue layer portions on the other side of firing beam 60 together.

[0058] In certain circumstances, the heat generated by activated electrode surfaces 50, 52 can denature the collagen within the tissue layer portions and, in cooperation with compressive force provided by jaws 42, 44, the denatured collagen can form a seal within the tissue layer portions. Thus, the severed ends of the natural lumen defining anatomical structure are hemostatically sealed shut, such that the severed ends will not leak bodily fluids. In various embodiments, electrode surfaces 50, 52 may be activated with bipolar RF energy before firing beam 60 begins to translate distally and thus before the tissue is even severed. For example, such timing may be provided in versions where button 26 serves as a mechanical lockout relative to trigger 24 in addition to serving as a switch between power source 80 and electrode surfaces 50, 52.

[0059] While several of the teachings below are described as variations to electrosurgical instrument 10, it should be understood that various teachings below may also be incorporated into various other types of devices. By way of example only, in addition to being readily incorporated into electrosurgical instrument 10, various teachings below may be readily incorporated into the devices taught in any of the references cited herein, other types of electrosurgical devices, alternative energy modality devices, surgical staplers, surgical clip appliers, and tissue graspers, among various other devices. Other suitable devices into which the

following teachings may be incorporated will be apparent to those of ordinary skill in the art in view of the teachings herein.

[0060] In various embodiments, the surgical instrument may comprise a two stage clamping mechanism configured to provide a higher clamp force to part the muscular layer of a blood vessel and a lower clamp force to seal across the adventitia. Without wishing to be bound to any particular theory, it is believe that the lower clamp force facilitates the proper heating rate to generate a higher strength seal across the adventitia layers relative to the higher clamp force.

[0061] In various embodiments, as shown in FIG. 5, trigger 24 may be movable relative to hand piece 20 between an unactuated position and one or more actuated positions. In various embodiments, trigger 24 is movable through a first range of motion from an unactuated position 1 to a first actuated position 2. In various embodiments, the first range of motion may be from an unactuated position 1 to position 3 and/or position 4, and from position 3 and/or position 4 to first actuated position 2. In various embodiments, trigger 24 is movable through a second range of motion from the first actuated position 2 to a second actuated position 3. In various embodiments, trigger 24 is movable through a third range of motion from the second actuated position 3 to the unactuated position 1. In various embodiments, trigger 24 is movable through a fourth range of motion from the unactuated position 1 to the third actuated position 4. In various embodiments, trigger 24 is movable through a fifth range of motion from the third actuated position 4 to the unactuated position 1. In various embodiments, the second actuated position 3 and third actuated position 4 may be the same or different.

[0062] In various embodiments, as described above, jaws 42, 44 may apply compressive force, or coaptation force, to tissue captured therebetween. In various embodiments, jaws 42, 44 may apply a first compressive force when trigger 24 is in the first actuated position 2, a second compressive force when trigger 24 is in the second actuated position 3, and a third compressive force when trigger 24 is in the third actuated position 4. In various embodiments, referring to FIG. 5, jaws 42, 44 may be in a closed position characterized by a first compressive force when trigger 24 is in the first actuated position. In various embodiments, jaws 42, 44 may be in a closed position characterized by a second compressive force when trigger 24 is in the second actuated position. In various embodiments, jaws 42, 44 may be in a closed position characterized by a third compressive force when trigger 24 is in the third actuated position. In

various embodiments, jaws 42, 44 may be in an open position when trigger 24 is in the unactuated position.

[0063] In various embodiments, the first compressive force, second compressive force, and third compressive force may be different. In various embodiments, the first compressive force may be greater than the second compressive force. In various embodiments, the second compressive force may be greater than or equal to the third compressive force. In various embodiments, the first compressive force, second compressive force, and third compressive force may be individually selected from up to about 10 pounds per square inch ("psi"), such as, for example, about 1 psi to about 10 psi, about 2 psi to about 8 psi, about 3 psi to about 5 psi, and about 4 psi to about 6 psi. In various embodiments, the first compressive force may be about 4 psi to about 6 psi and the second compressive force may be about 2 psi to about 4 psi. In various embodiments, the first compressive force may be about 6 psi and the second compressive force may be about 4 psi. In various embodiments, the first compressive force may be about 4 psi and the second compressive force may be about 2 psi. In various embodiments, the first compressive force may be about 3 psi to about 5 psi and the second compressive force may be about 1 psi to about 3 psi. In various embodiments, the first compressive force may be about 5 psi and the second compressive force may be about 3 psi. In various embodiments, the first compressive force may be about 3 psi and the second compressive force may be about 1 psi. In various embodiments, jaws 42, 44 may not apply compressive force to the tissue when trigger 24 is in the unactuated position.

[0064] In various embodiments, electrosurgical instrument 10 may comprise a trigger assembly configured to actuate end effector 40 to provide variable compressive force to tissue captured between jaws 42, 44 when trigger 24 is in the first actuated position, second actuated position, and/or third actuated position, as described in greater detail below. In various embodiments, the trigger assembly may be configured to limit the compressive force to a first compressive force when trigger 24 is in the first actuated position and limit the compressive force to a second compressive force when trigger 24 is in the second actuated position. In various embodiments, the trigger assembly may be configured to limit the compressive force to a third compressive force when trigger 24 is in the third actuated position.

[0065] In various embodiments, electrosurgical instrument 10 may comprise a trigger assembly configured to actuate end effector 40 to provide variable compressive force to tissue captured

between jaws 42, 44 through the first range of motion, second range of motion, and/or third range of motion, as described in greater detail below. In various embodiments, the trigger assembly may be configured to limit the compressive force to a first compressive force through the first range of motion and limit the compressive force to a second compressive force through the second range of motion. In various embodiments, the trigger assembly may be configured to limit the compressive force to a third compressive force through the fourth range of motion.

[0066] In various embodiments, the trigger assembly may comprise one or more detent features and/or other kind of feature(s) to provide an audible and/or tactile indication of the angular position of end effector about the longitudinal axis defined by sheath. Referring to FIG. 16, in various embodiments, trigger 1024 may be pivotally attached to hand piece 1020. Trigger 1024 may comprise a living hinge 1054. In various embodiments, the living hinge may provide an audible and/or tactile indication to the user. For example, a trigger 1024 may be squeezed toward a pistol grip 1022 to actuate an end effector (not shown). The living hinge may provide the audible and/or tactile indication when trigger 1024 is in an actuated position. Various examples of devices comprising audible and/or tactile indicators are described in U.S. Patent App. Ser. No. 12/ 842,565, filed July 23, 2010, entitled "ELECTROSURGICAL CUTTING AND SEALING INSTRUMENT", the disclosure of which is incorporated by reference herein.

[0067] In various embodiments, in use, end effector 40 may be inserted into a patient via a trocar to a desired position and orientation relative to an anatomical structure within the patient. In various embodiments, the user may operate trigger 24 through the first range of motion to capture two layers of tissue of the anatomical structure 42, 44 when the anatomical structure has a diameter greater than about 3 mm. As described above, flanges 62, 66 cammingly act to pivot jaw 44 toward jaw 42 when firing beam 60 is actuated distally by squeezing trigger 24 from the unactuated position to the first actuated position. Jaws 42, 44 may apply the first compressive force to the layers of tissue captured therebetween when trigger 24 is in the first actuated position. In various embodiments, the first compressive force may compress the anatomical structure such that the inner layers of the anatomical structure are extruded and separated and only the outer layer of the anatomical structure is between jaws 42, 44. In various embodiments, activation button 26 may serve as a mechanical lockout against trigger 24 such that a bipolar RF current may not flow to electrode surfaces 50, 52 when trigger 24 is in the first actuated position.

[0068] In various embodiments, the user may operate trigger 24 through the second range of motion to sever the clamped tissue layers between jaws 42, 44 and thermally weld the severed tissue layers. As described above, distal blade 64 severs the clamped tissue layers as firing beam 60 continues to advance distally by the user squeezing trigger 24 from the first actuated position to the second actuated position. Jaws 42, 44 may apply the second compressive force to the layers of tissue captured therebetween when trigger 24 is in the second actuated position. In various embodiments, the second compressive force may allow the inner severed tissue layer portions directly contact each other. With jaws 42, 44 applying the second compressive force to the severed tissue layer portions, electrode surfaces 50, 52 are activated with bipolar RF energy by the user depressing activation button 26. As described above, a bipolar RF current flows between firing beam 60 and electrode surfaces 50, 52 through the compressed regions of severed tissue layer portions to thermally welds the tissue layer portions on one side of firing beam 60 together and the tissue layer portions on the other side of firing beam 60 together. In various embodiments, the inner severed tissue layer portions of the anatomical structure may be thermally welded to each other. In various embodiments, activation button 26 may serve as a mechanical lockout against trigger 24 such that a bipolar RF current may not flow to electrode surfaces 50, 52 unless trigger 24 is in the second actuated position and button 26 is being pressed simultaneously.

[0069] In various embodiments, in use, end effector 40 may be inserted into a patient via a trocar to a desired position and orientation relative to an anatomical structure within the patient. In various embodiments, the user may operate trigger 24 through the third range of motion to capture two layers of tissue of the anatomical structure 42, 44 when the anatomical structure has a diameter up about 3 mm. As described above, flanges 62, 66 cammingly act to pivot jaw 44 toward jaw 42 when firing beam 60 is actuated distally by squeezing trigger 24 from the unactuated position to the third actuated position. The user may continue to operate trigger 24 through the third range of motion to sever the clamped tissue layers between jaws 42, 44 and thermally weld the severed tissue layers. As described above, distal blade 64 severs the clamped tissue layers as firing beam 60 continues to advance distally by the user squeezing trigger 24 from the first actuated position to the third actuated position. Jaws 42, 44 may apply the third compressive force to the layers of tissue captured therebetween when trigger 24 is in the third actuated position.

[0070] With jaws 42, 44 applying the third compressive force to the severed tissue layer portions, electrode surfaces 50, 52 are activated with bipolar RF energy by the user depressing activation button 26. As described above, a bipolar RF current flows between firing beam 60 and electrode surfaces 50, 52 through the compressed regions of severed tissue layer portions to thermally welds the tissue layer portions on one side of firing beam 60 together and the tissue layer portions on the other side of firing beam 60 together. In various embodiments, activation button 26 may serve as a mechanical lockout against trigger 24 such that a bipolar RF current may not flow to electrode surfaces 50, 52 unless button trigger is in the third actuated position and button 26 is being pressed simultaneously.

[0071] As described above, in various embodiments, electrosurgical instrument 10 may comprise a trigger assembly operable to control jaws 44, 42 to thereby selectively compress tissue between jaws 42, 44 at various compressive forces. Various embodiments, of the trigger assembly and other components of hand piece 20 are described in greater detail below, while further examples will be apparent to those of ordinary skill in the art in view of the teachings herein.

[0072] As described above, in various embodiments, firing beam 60 may be advanced distally by squeezing trigger 24 toward pistol grip 22 to the actuated position; while firing beam 60 may be retracted proximally by releasing trigger 24 and/or by actively moving trigger 24 away from pistol grip 22 to the unactuated position. In various embodiments, the trigger assembly may comprise a yoke to couple trigger 24 to firing beam 60. In various embodiments, the trigger assembly may further comprise a link arm to couple trigger 24 to firing beam 60. Of course, firing beam 60 may be moved in any other suitable fashion.

[0073] In various embodiments, an electrosurgical instrument may generally comprise a shaft comprising a proximal end and a distal end, an end effector extending from the distal end of the shaft, wherein the end effector is operable to grasp tissue, a hand piece extending from the proximal end, wherein the hand piece comprises a pistol grip and a trigger assembly extending from the hand piece, wherein the trigger assembly comprises a trigger movable relative to the pistol grip between an unactuated position and a first actuated position and a second actuated position, wherein the trigger is operable to control the end effector to selectively grasp tissue at a first compressive force when the trigger is in the first actuated position and a second compressive force when the trigger is in the second actuated position.

[0074] In various embodiments, referring to FIGS. 6 and 7, electro-surgical instrument 110 may generally comprise a bypass latch or over-center mechanism configured to define a bypass pathway 113 for trigger 124. In various embodiments, hand piece 120 comprises pistol grip 122, bypass latch leaf spring 111, and a trigger assembly comprising trigger 124 pivotally attached to yoke 138. Trigger 124 may comprise extension arm 125 comprising slot 113 defining a bypass pathway. One end of bypass latch leaf spring 111 may be fixedly attached to hand piece 120 and the free end of bypass latch leaf spring 111 may be disposed in slot 113. As shown in FIG. 7, the free end of bypass latch leaf spring 111 engages a first portion of slot 113 when trigger 124 is in the unactuated position 1, a second portion of slot 113 when trigger 124 is in the first actuated position 2, and a third portion of slot 113 when trigger 124 is in the second actuated position 3.

[0075] In use for tissues having large diameters or thicknesses, bypass latch leaf spring 111 may be configured to pass through the first actuated position 2 and release to or near the second actuated position 3 when electro-surgical instrument 110 is activated to seal the tissue between jaws (not shown). In this way, the user crushes the tissue at the first actuated position 2 such that the inner tissue layers may be extruded laterally before end effector (not shown) is activated to cut and coagulate the outer tissue layers at the second actuated position 3. In use for tissues have small diameters, bypass latch leaf spring 111 may be configured to pass directly to the third actuated position 4 when electro-surgical instrument 110 is activated to capture, cut, and/or seal the tissue between jaws (not shown). Without wishing to be bound to any particular theory, it is believed that electro-surgical instruments according to the present disclosure may utilize substantially similar power and clamp force to coagulate larger blood vessels as current ultrasonic shear devices use to coagulate smaller blood vessels.

[0076] In various embodiments, referring to FIGS. 8A-G, hand piece 220 may generally comprise yoke 238 longitudinally slideable relative to hand piece 220, trigger 224 slideably attached to yoke 238 and rotationally attached to hand piece 220, and link arm 236 fixedly attached to yoke 238 and rotationally attached to hand piece 220. Link arm 236 may comprise slot 233. Trigger 224 may be coupled to link arm 236 by trigger pin 216. One end of trigger pin 216 may be disposed in slot 233. In various embodiments, slot 233 may comprise a radial feature configured to act as a cam and trigger pin 216 may be configured to act as a cam follower. In various embodiments, slot 233 may comprise a first portion and a second portion. In various embodiments, the first portion of slot 233 may comprise a radial feature and the

second portion of slot 233 may comprise a longitudinal feature. For example, as shown in FIG. 8A, slot 233 may comprise an L-shape wherein the first portion of slot 233 extends proximally and radially from a plane including the longitudinal axis of hand piece 220, and the first portion of slot 233 extends parallel to the plane including the longitudinal axis of hand piece 220.

[0077] In use, referring to FIGS. 8A-G, when trigger 224 moves from an unactuated position (FIG. 8A) through the first range of motion (FIGS. 8B, 8C) to the first actuated position (FIG. 8C), trigger pin 216 slides along the first portion of slot 233 to convert the movement of trigger 224 into proximal linear movement of yoke 238. Trigger 224 may continue to move from the first actuated position through a second range of motion (FIG. 8D) to the second actuated position (FIG. 8D) when trigger pin 216 slides along a second portion of slot 233 to convert the movement of trigger 224 into distal linear movement of yoke 238. In various embodiments, yoke 238 may travel a first distance through the first range of motion and a second distance through a second range of motion. In various embodiments, the first distance may be greater than or equal to the second distance. In various embodiments, the difference between the first distance and second distance may decrease the compressive force applied to captured tissue from the first compressive force to the second compressive force.

[0078] Referring to FIGS. 8D-8G, when trigger 224 moves from the second actuated position (FIG. 8D) through the third range of motion (FIGS. 8E-G) to the unactuated position, a spring (not shown) may return trigger 224 to an unactuated position where it is pivoted away from the longitudinal axis. In various embodiments, referring to FIG. 8E, trigger 224 is pivotable about a pivot point that is fixed relative to hand piece 220. When trigger 224 rotates away from the longitudinal axis, trigger pin 216 slides along the second portion of slot 233 to the first portion of slot 233. As shown in FIG. 8F, as trigger 224 continues to rotate away from the longitudinal axis, trigger pin 216 slides along the first portion of slot 233 to convert the movement of trigger 224 into proximal linear movement of yoke 238. The unactuated position is illustrated in FIG. 8G.

[0079] In various embodiments, the trigger assembly may comprise mechanical assistance to trigger 24 as it approaches the end of its return stroke. In various embodiments, it may also be desirable to provide a substantially constant amount of resistance to the user squeezing trigger during the entire range of motion such that the resistance forces encountered by the user are not substantially greater during certain stages of the firing stroke and return stroke.

[0080] In various embodiments, referring to FIGS. 9A-G, hand piece 320 may generally comprise yoke 338 longitudinally slideable relative to hand piece 320, trigger 324 slidingly attached to yoke 338 and rotationally attached to hand piece 320, and link arm 336 pivotally attached to yoke 338 and rotationally attached to trigger 324. Trigger 324 may be coupled to link arm 336 by trigger pin 316 as described above. In various embodiments, trigger 324 may be configured to act as a cam and slot 333 and link 336 may comprise a projection configured to act as a cam follower 337. In various embodiments, link 336 may comprise projection 337 to engage portion 325 of trigger 324 comprising trigger pin 316. In various embodiments, projection 337 may engage a first portion of trigger 324 when trigger 324 is in the first actuated position and a second portion of trigger 324 when trigger 324 is in the second actuated position. In various embodiments, projection 337 may comprise an angled surface. For example, as shown in FIG. 9A, projection 337 may comprise a pentagon-shape including an angled surface 337a. In various embodiments, angled surface 337a of projection 337 may engage a first portion 325 of trigger 324 when trigger 324 is in the first actuated position and a second portion 326 of trigger 324 when trigger 324 is in the second actuated position.

[0081] In use, referring to FIGS. 9A-G, when trigger 324 moves from an unactuated position (FIG. 9A) through the first range of motion to the first actuated position (FIG. 9B), a first portion of angled surface 337a of projection 337 engages a first portion of trigger 324 to convert the movement of trigger 324 into proximal linear movement of yoke 338. Trigger 324 may continue to move from the first actuated position through a second range of motion (FIG. 9C) to the second actuated position (FIG. 9D) when a second portion of angled surface 337a of projection 337 engages a second portion of trigger 324 to convert the movement of trigger 324 into distal linear movement of yoke 338. As shown in FIG. 9C, in various embodiments, the second portion of angled surface 337a may comprise a complementary angle to the second portion of trigger 324. The complementary surface of trigger 324 may contact the complementary surface of projection 337a when trigger 324 moves from the first actuated position through the second range of motion to the second actuated position. As described above, in various embodiments, yoke 338 may travel a first distance through the first range of motion and a second distance through a second range of motion such that the difference between the first distance and second distance may decrease the compressive force applied to captured tissue from the first compressive force to the second compressive force. As described above, the user may release

trigger 324, and the spring (not shown) may return trigger 324 to an unactuated position. When trigger 324 moves from the second actuated position (FIG. 9E) through the third range of motion (FIG. 9F) to the unactuated position (FIG. 9G), in various embodiments, trigger 324 may be coupled to link arm 336 by trigger pin 316 disposed in slot 333 to prevent trigger 324 from over travel and locking.

[0082] In various embodiments, referring to FIGS. 10A-D, hand piece 420 may generally comprise yoke 438 longitudinally slideable relative to hand piece 420, trigger 424 pivotally attached to yoke 338, and link arm 436 pivotally attached to yoke 438. Trigger 424 may be coupled to link arm 436 by trigger pin 416 disposed in trigger slot 417. Trigger 424 may comprise a surface comprising relief notch 425 configured to act as a cam and link arm 436 may comprise a projection 437 configured to act as a cam follower. A return spring (not shown) may be coupled to yoke 438 by pin (not shown) configured to resiliently bias yoke 438 distally and projection 437 of link arm 436 to contact the surface of trigger 424. In various embodiments, projection 437 of link arm 436 may engage the surface of trigger 424 lacking relief notch 425 when trigger 424 is in the first actuated position and engage relief notch 425 when trigger 424 is in the second actuated position. In various embodiments, projection 437 of link arm 438 may comprise a complementary shape to relief notch 425. For example, as shown in FIG. 10D, projection 437 of link arm 438 may comprise a complementary shape to relief notch 425.

[0083] In use, referring to FIGS. 10A-D, when trigger 424 moves from an unactuated position (FIG. 10A) through the first range of motion to the first actuated position (FIGS. 10B and 10C), projection 437 of link arm 438 engages a surface of trigger 424 lacking relief notch 425 to compress return spring (not shown) and convert the movement of trigger 424 into proximal linear movement of yoke 438. Trigger 424 may continue to move from the first actuated position through a second range of motion to the second actuated position (FIG. 10D) when projection 437 of link arm 438 engages relief notch 425 to decompress return spring (not shown), and to convert the movement of trigger 424 into distal linear movement of yoke 438. In various embodiments, trigger pin 417 may contact a first portion of trigger slot 417 when trigger 424 is in the first actuated position. Trigger pin 417 may slide along trigger slot 417 through the second range of motion to a second portion of trigger slot 417 when trigger 423 is in the second actuated position. As described above, in various embodiments, yoke 438 may travel a first distance through the first range of motion and a second distance through a second range of motion such

that the difference between the first distance and second distance may decrease the compressive force applied to captured tissue from the first compressive force to the second compressive force. In various embodiments, as shown in FIG. 10D, the second distance may relate to the depth of relief notch 425 and/or length of trigger slot 417. As described above, the user may release trigger 424, and trigger pin 416 may slide along trigger slot 417 to the first portion of trigger slot 417, and projection 437 of link 438 may rotate out of relief notch 425 to return trigger 324 to an unactuated position.

[0084] In various embodiments, referring to FIGS. 11A-C, hand piece 520 may generally comprise yoke 538 longitudinally slideable relative to hand piece 520, trigger 524 pivotally attached to yoke 538, and link arm 536 pivotally attached to yoke 538. In various embodiments, hand piece 520 may comprise a handle shroud slot 544. Trigger 524 may be coupled to link arm 536 by trigger pin 516 disposed in trigger slot 517. Link arm 537 may comprise a projection comprising a link pin 537. Link pin 537 may be disposed in handle shroud slot 544. In various embodiments, link pin 537 may slide along handle shroud slot 544. As discussed above, a return spring (not shown) may be coupled to yoke 538 by pin (not shown) configured to resiliently bias yoke 538 distally. In various embodiments, link pin 537 may contact a first portion of handle shroud slot 544 when trigger 524 is in the first actuated position and a second portion of handle shroud slot 544 when trigger 524 is in the second actuated position.

[0085] In use, referring to FIGS. 11A-C, when trigger 524 moves from an unactuated position (FIG. 11A) through the first range of motion to the first actuated position (FIG. 11B), link pin 537 slides along slot 544 to compress return spring (not shown) and convert the movement of trigger 524 into proximal linear movement of yoke 538. As shown in FIG. 11B, link pin 537 may engage a first portion of slot 544 when trigger 524 is in the first actuated position. Trigger 524 may continue to move from the first actuated position through a second range of motion to the second actuated position (FIG. 11C) when link pin 537 continues to travel along slot 544 to decompress return spring (not shown), and to convert the movement of trigger 524 into distal linear movement of yoke 538. As shown in FIG. 11B, link pin 537 may engage a second portion of slot 544 when trigger 524 is in the second actuated position. As described above, in various embodiments, yoke 538 may travel a first distance through the first range of motion and a second distance through a second range of motion such that the difference between the first distance and second distance may decrease the compressive force applied to captured tissue from the first

compressive force to the second compressive force. In various embodiments, as shown in FIG. 11C, the second distance may relate to the configuration of slot 544 and/or length of trigger slot 517. As described above, the user may release trigger 524, and trigger pin 516 may slide along trigger slot 517, link pin 537 may slide along slot 544 to the first portion of slot 544 to return trigger 524 to an unactuated position. In various embodiments, slot 544 may prevent trigger 524 from over travel and locking.

[0086] In various embodiments, referring to FIGS. 14A-C, hand piece 620 may generally comprise yoke 638 longitudinally slideable relative to hand piece 620, trigger 624 slideably attached to yoke 638 and pivotally attached to hand piece 620, and link arm 636 pivotally attached to yoke 638 and trigger 624. In various embodiments, referring to FIGS. 12 and 13, hand piece 620 may comprise slot 644 comprising first portion 644a and second portion 644b, and yoke 638 may comprise notch 617 comprising first portion 617a and second portion 617b. Rear yoke pin 618 may link hand piece 620, link arm 636, and yoke 638. A first end of rear yoke pin 618 may be disposed in slot 644 and a second end of rear yoke pin may be disposed in notch 617. In various embodiments, a first end of the rear yoke pin may engage a first portion 644a of slot 644 when the trigger is in the first actuated position, an upward step of slot 644 between first portion 644a and second portion 644b when the trigger is moved through a second range of motion, and a second portion 644b of slot 644 when the trigger is in the second actuated position. In various embodiments, the upward step may comprise an angled portion of the first portion 644a of slot 644. In various embodiments, a second end of the rear yoke pin may engage a first portion 617a of notch 617 when the trigger is in the first actuated position and second portion 617b when the trigger is in the second actuated position.

[0087] In use, referring to FIGS. 14A-C, when trigger 624 moves from an unactuated position (FIG. 14A) through the first range of motion to the first actuated position (FIG. 14B), the first end of the rear yoke pin may slide along the first portion 644a of slot 644 to convert the movement of trigger 624 into proximal linear movement of yoke 638. The second end of the rear yoke pin may rest in the first portion 617a of notch 617 when the trigger moves from an unactuated position through the first range of motion to the first actuated position. The first actuated position is illustrated in FIG. 14B. Trigger 624 may continue to move from the first actuated position through a second range of motion to the second actuated position (FIG. 14C) when the first end of the rear yoke pin slides along the upward step of slot 644 to the second

portion 644b of slot 644 and the second end of the rear yoke pin may move from the first portion 617a to the second portion 617b of notch 617 to convert the movement of trigger 624 into distal movement of yoke 638. In various embodiments, yoke 638 may travel in an upward, distal direction when the first end of the rear yoke pin slides along the upward step of slot 644 and a linear distal direction when the first end of the rear yoke pin slides along the second portion 644b of slot 644. In various embodiments, the angular movement yoke 638 along slot 644 relative to the longitudinal axis and/or the movement of the rear yoke pin in notch 617 during the second range of motion may provide an audible and/or tactile indication to the user that trigger (not shown) is in the second actuated position. As discussed above, a return spring (not shown) may be coupled to yoke 638 by pin (not shown) configured to resiliently bias yoke 638 distally. As described above, the user may release the trigger, and the first end of the rear yoke pin may slide along slot 644 from the second portion 644b to the first portion 644a of slot 644 and the second end of the rear yoke pin may move from the second portion 617b to the first portion 617a of notch 617 to return the trigger to an unactuated position. In various embodiments, slot 644 may prevent the trigger from over travel and locking.

[0088] In various embodiments, referring to FIGS. 15A-4, hand piece 720 may generally comprise yoke 738 longitudinally slideable relative to hand piece 720, trigger 724 pivotally attached to yoke 738, and link arm 736 fixedly attached to yoke 738. Link arm 736 may comprise slot 733. Trigger 724 may comprise trigger slot 717. Trigger 724 may be coupled to link arm 736 by trigger pin 716. Trigger pin 716 may be disposed in link pin 732. One end of trigger pin 716 may be disposed in trigger slot 717. One end of link pin 732 may be disposed in trigger slot 717 and the other end of link pin 732 may be disposed in slot 733. In various embodiments, slots 717, 733 may be configured to act as a cam and trigger pin 716 and link pin 732 may be configured to act as a cam follower. In various embodiments, slots 716, 733 may individually comprise a first portion and a second portion. In various embodiments, the first portion of slot 733 may comprise an angled feature and the second portion of slot 733 may comprise a vertical feature relative to the longitudinal axis. For example, as shown in FIG. 15A, the first portion of slot 733 may extend distally and vertically from a plane including the longitudinal axis of hand piece 220, and the second portion of slot 733 may extend perpendicular parallel to the plane including the longitudinal axis of hand piece 220.

[0089] In use, referring to FIGS. 15A-K, when trigger 724 moves from an unactuated position (FIG. 15A) through the first range of motion (FIGS. 15B, 15C) to the first actuated position, link pin 732 slides along the first portion of slot 733 to convert the movement of trigger 724 into proximal linear movement of yoke 738. In various embodiments, link pin 732 may contact a first portion of trigger slot 717 when trigger 724 is in the unactuated position and first actuated position. In various embodiments, trigger pin 717 may not move in trigger slot 716 when trigger 724 moves through the first range of motion. The first actuated position is illustrated in FIG. 15D. Trigger 724 may continue to move from the first actuated position through a second range of motion (FIG. 15E, 15F) to the second actuated position when trigger pin 716 slides along a second portion of slots 717, 733 to convert the movement of trigger 724 into distal linear movement of yoke 738. The second actuated position is illustrated in FIG. 15G. As described above, in various embodiments, yoke 738 may travel a first distance through the first range of motion and a second distance through a second range of motion such that the difference between the first distance and second distance may decrease the compressive force applied to captured tissue from the first compressive force to the second compressive force. In various embodiments, as shown in FIGS. 15D, 15G, the second distance may relate to the length of trigger slot 717.

[0090] Referring to FIGS. 15G-K, when trigger 724 moves from the second actuated position (FIG. 15G) through the third range of motion (FIGS. 15H-J) to the unactuated position (FIG. 15K), a spring (not shown) may return trigger 724 to an unactuated position where it is pivoted away from the longitudinal axis. In various embodiments, referring to FIGS. 15H and 15I, the user may release trigger 724, and trigger pin 716 may slide along the second portion of slot 733 to the first portion of slot 733 while remaining stationary in the second portion of trigger slot 717. Referring to FIG. 15J, when trigger pin 716 contacts the first portion of slot 733, trigger pin 716 may slide along the second portion of trigger slot 717 to the first portion of slot 717. As trigger 724 continues to rotate away from the longitudinal axis, link pin 732 slides along the first portion of slots 733 to convert the movement of trigger 724 into distal linear movement of yoke 738. The unactuated position is illustrated in FIG. 15K. In various embodiments, at least one of slots 717, 733 may prevent trigger 724 from over travel and locking.

[0091] In various embodiments, a surgical instrument may be configured to apply a compressive force to captured tissue. As described above, for example, jaws may be apply a compressive

force to tissue captured therebetween. In various embodiments, referring to FIGS. 17A-H, the compressive force may comprise an opposing compressive force and/or a rolling compressive force. As shown in FIGS. 17A-D, the inner and outer layers of a vessel may remain adhered when subjected to opposing compressive force and energy is applied to the tissue. The adventitia layer may retract under heat resulting in an inner muscle layer bond. The inner muscle layer bond may be weaker than an adventitia-adventitia bond. In various embodiments, jaws may apply opposing compressive force and rolling compressive force to mechanically separate the inner and outer vessel layers when jaws close. As shown in FIGS. 17E-H, the inner and outer layers of the vessel may separate when subject to opposing compressive force and rolling compressive force. The separated inner muscle layer may retract before the adventitia layer, and thereby, an adventitia-adventitia bond may be formed when energy is applied to the tissue. The separation of the inner muscle layer may reduce the occurrence of the adventitia layer retracting during sealing by allowing the inner muscle layer to retract inside the vessel as heat begins to build. In various embodiments, sealing and/or welding compressed and rolled tissue layers may form a stronger adventitia-adventitia bond relative to sealing and/or welding compressed tissue layers.

[0092] Referring to FIGS. 18A and 18B, in various embodiments, end effector 840 may comprise first jaw 842 and second jaw 844. Second jaw 844 is longitudinally slideable relative to shaft 830; while first jaw 842 pivots relative to shaft 830, toward and away from second jaw 844. First jaw 842 and second jaw 844 may comprise a plurality of teeth serrations 846. The teeth serrations 846 may allow tissue to be grasped, manipulated, coagulated, and/or cut without slipping between jaws 842, 844. In various embodiments, hand piece 820 may comprise connector base 835 configured to retract second jaw 844 relative to shaft 830. Referring to FIGS. 19A and 19B, connector base 835 and second jaw 844 may be resiliently biased to a distal position by spring 838. As shown in the insert in FIG. 19A, jaw 842 may not extend to the tip of jaw 844. Connector base is configured to cam against a ramp features in hand piece 820 to retract second jaw 844 relative to shaft 830 when firing beam is retracted to a proximal position. Hand piece 820 may include stop members 880 located proximal to connector base 835 and spring 838. As shown in FIG. 19B, stop member 880 is configured to engage a proximal face of connector base 835 when firing beam advances distally to close jaws 842, 844. This camming capability may facilitate use of end effector 840 to separate layers of tissue, such as, for example,

the adventitia layer and inner muscle layers of a vessel. As shown in the insert in FIG. 19B, jaw 844 may move proximally to contact the tip of jaw 842 in the closed position. In various embodiments, longitudinal movement of the actuator may provide pivoting of first jaw 842 relative to shaft 830 and relative to second jaw 844 and retraction of second jaw 844 relative to shaft 830.

[0093] In various embodiments, a surgical instrument may generally comprise a shaft comprising a proximal end and a distal end; an ultrasonic waveguide at least partially positioned within the shaft, the waveguide having a proximal end and a distal end; an ultrasonically actuated blade positioned at the distal end of the waveguide; a clamp arm assembly pivotally connected to the distal end of the shaft, wherein the clamp arm assembly comprises at least two camming members rotationally attached to a clamp arm, wherein the clamp arm is movable between an open position and a closed position relative to the blade to compress tissue intermediate the clamp arm and blade when in the closed position, and wherein the at least two camming members rotate in opposite directions when the clamp arm moves from the open position and a closed position. In various embodiments, the at least two camming members may selectively compress tissue at a first compressive force when a first portion of the camming member contacts tissue and a second compressive force when a second portion of the camming member contacts tissue. In various embodiments, the first compressive force may be different from the second compressive force. In various embodiments, the first compressive force may be greater than or equal to the second compressive force. It may be contemplated to combine the aforementioned configuration with alternative energy modalities or combinations thereof as mentioned earlier in this specification.

[0094] In various embodiments, referring to FIG. 20, an end effector 910 may comprise clamp arm assembly 941 to grip tissue and/or compress tissue against ultrasonic blade 964. Clamp arm assembly 941 may be pivotally attached to the distal end of shaft 930 by pivot pin 943. In various embodiments, clamp arm assembly 941 pivots relative to blade 964, toward and away from blade 964. As described above, actuators (not shown) may extend through sheath 932 and be joined with clamp arm 941 and at pivotal coupling 943 such that longitudinal movement of the actuator through shaft 930 provides pivoting of clamp arm 941 relative to shaft 930 and relative to blade 964. Of course, clamp arm 941 may instead have any other suitable kind of movement and may be actuated in any other suitable fashion. In various embodiments, clamp

arm assembly may comprise at least one camming member 942, 944 rotationally attached to clamp arm 941. Each the camming member 942, 944 may independently rotate in one of a clockwise direction and a counter clockwise direction relative to shaft 930 and blade 964 when clamp arm 941 is moved from the open position to the closed position. In various embodiments, camming members 942, 944 may rotate in opposite directions. In various embodiments, the camming members 942, 944 may rotate in the same direction. In various embodiments, camming members 942, 944 may rotate simultaneously. In various embodiments, camming members 942, 944 may rotate separately.

[0095] In various embodiments, clamp arm 941 may comprise actuating pin 917 for rotating camming member 944 relative to waveguide 964. Actuating pin 917 may be located at a proximal end of camming member 944. Actuating pin 917 may operatively engage with notch 916 of shaft 930 when clamp arm 941 pivots to rotate camming member 944. For example, actuating pin 917 may engage notch 916 when clamp arm 941 pivots toward blade 964 to rotate camming member 944 counterclockwise. Actuating pin 917 may engage notch 916 when clamp arm 941 pivots away from blade 964 to rotate camming member 944 clockwise. In various embodiments, each camming member 942, 944 may comprise actuating pin to individually engage with a corresponding notch in shaft 930. In various embodiments, camming member 944 may comprise actuating pin 917 to engage with notch 916 of shaft 930 and gears (not shown) to operatively engage with gears (not shown) of at least one other camming member 942, 944 such that rotational movement of camming member 944 rotates camming member 942. Of course, camming members 942, 944 may instead have any other suitable kind of movement and may be actuated in any other suitable fashion.

[0096] In various embodiments, the camming member may selectively compress tissue at a first compressive force when a first portion of the camming member contacts tissue and a second compressive force when a second portion of the camming member contacts tissue, wherein the first compressive force is different from the second compressive force. In various embodiments, the first compressive force is greater than the second compressive force. In various embodiments, referring to FIGS. 21A and 21B, camming members 942, 944 may comprise a generally circumferential tissue T contacting surface comprising at least one protrusion 942a, 944a. The protrusions 942a, 944a may extend above the surface of the camming members 942, 944, respectively. In various embodiments, protrusion 942a, 944a may comprise a curved

portion of a generally comma-shape. In various embodiments, camming members 942, 944 may selectively compress tissue T at a first compressive force when a first portion of camming member 942, 944 comprising protrusion 942a, 944a contacts tissue T and a second compressive force when a second portion of the camming member 942, 944 lacking the protrusion contacts tissue T. In various embodiments, the camming members 942, 944 may contact the tissue T and rotationally engage the tissue T to shear and/or scrape any calcification on the external and/or internal surfaces of the tissue T.

[0097] While various embodiments described above include a pistol grip, it should be understood that the foregoing teachings may be readily applied to devices having various other kinds of grips. By way of example only, a variation of trigger and cam lever may be provided in accordance with the above teachings in a device having a scissor grip. Various examples of devices comprising a scissor grip is described in U.S. Patent App. Ser. No. 13/426,084, filed March 21, 2012, entitled "ENERGY-BASED SCISSORS DEVICE", the disclosure of which is incorporated by reference herein. Other kinds of grips that may be combined with the above teachings will be apparent to those of ordinary skill in the art. Furthermore, a variation of trigger and cam lever may be readily incorporated into devices having various other kinds of end effectors, including but not limited to tissue graspers, tissue retrieval pouch deploying instruments, surgical staplers, ultrasonic surgical instruments, etc.

[0098] It should also be understood that any of the devices described herein may be modified to include a motor or other electrically powered device to drive an otherwise manually moved component. Various examples of such modifications are described in U.S. Pub. No. 2012/0116379, entitled "Motor Driven Electrosurgical Device with Mechanical and Electrical Feedback," published May 10, 2012, the disclosure of which is incorporated by reference herein. Various other suitable ways in which a motor or other electrically powered device may be incorporated into any of the devices herein will be apparent to those of ordinary skill in the art in view of the teachings herein.

[0099] It should also be understood that any of the devices described herein may be modified to contain most, if not all, of the required components within the medical device itself. More specifically, the devices described herein may be adapted to use an internal or attachable power source instead of requiring the device to be plugged into an external power source by a cable. Various examples of how medical devices may be adapted to include a portable power source are

disclosed in U.S. Provisional Application Ser. No. 61/410,603, filed Nov. 5, 2010, entitled "Energy-Based Surgical Instruments," the disclosure of which is incorporated by reference herein. Various other suitable ways in which a power source may be incorporated into any of the devices herein will be apparent to those of ordinary skill in the art in view of the teachings herein.

[0100] The devices disclosed herein may be designed to be disposed of after a single use, or they may be designed to be used multiple times. In either case, however, the device may be reconditioned for reuse after at least one use. Reconditioning may include a combination of the steps of disassembly of the device, followed by cleaning or replacement of particular pieces, and subsequent reassembly. In particular, the device may be disassembled, and any number of particular pieces or parts of the device may be selectively replaced or removed in any combination. Upon cleaning and/or replacement of particular parts, the device may be reassembled for subsequent use either at a reconditioning facility, or by a surgical team immediately prior to a surgical procedure. Those of ordinary skill in the art will appreciate that the reconditioning of a device may utilize a variety of different techniques for disassembly, cleaning/replacement, and reassembly. Use of such techniques, and the resulting reconditioned device, are all within the scope of this application.

[0101] Preferably, the various embodiments of the devices described herein will be processed before surgery. First, a new or used instrument is obtained and if necessary cleaned. The instrument can then be sterilized. In one sterilization technique, the instrument is placed in a closed and sealed container, such as a plastic or TYVEK® bag. The container and instrument are then placed in a field of radiation that can penetrate the container, such as gamma radiation, x-rays, or high-energy electrons. The radiation kills bacteria on the instrument and in the container. The sterilized instrument can then be stored in the sterile container. The sealed container keeps the instrument sterile until it is opened in the medical facility. Other sterilization techniques can be done by any number of ways known to those skilled in the art including beta or gamma radiation, ethylene oxide, and/or steam.

[0102] Although the various embodiments of the devices have been described herein in connection with certain disclosed embodiments, many modifications and variations to those embodiments may be implemented. For example, different types of end effectors may be employed. Also, where materials are disclosed for certain components, other materials may be

used. Furthermore, according to various embodiments, a single component may be replaced by multiple components, and multiple components may be replaced by a single component, to perform a given function or functions. The foregoing description and following claims are intended to cover all such modification and variations.

[0103] Any patent, publication, or other disclosure material, in whole or in part, that is said to be incorporated by reference herein is incorporated herein only to the extent that the incorporated materials does not conflict with existing definitions, statements, or other disclosure material set forth in this disclosure. As such, and to the extent necessary, the disclosure as explicitly set forth herein supersedes any conflicting material incorporated herein by reference. Any material, or portion thereof, that is said to be incorporated by reference herein, but which conflicts with existing definitions, statements, or other disclosure material set forth herein will only be incorporated to the extent that no conflict arises between that incorporated material and the existing disclosure material.

What is claimed is:

1. A surgical instrument, comprising:
 - a shaft comprising a proximal end and a distal end;
 - an end effector extending from the distal end of the shaft, wherein the end effector is operable to grasp tissue;
 - a handle extending from the proximal end, wherein the handle comprises a gripping portion; and
 - a trigger assembly extending from the handle, wherein the trigger assembly comprises a trigger movable relative to the gripping portion between an unactuated position and a first actuated position and a second actuated position, wherein the trigger is operable to control the end effector to selectively grasp tissue at a first compressive force when the trigger is in the first actuated position and a second compressive force when the trigger is in the second actuated position.
2. The surgical instrument of claim 1, wherein the first compressive force is greater than the second compressive force.
3. The surgical instrument of claim 1, wherein the first compressive force and second compressive force are independently selected from 1 psi to 10 psi.
4. The surgical instrument of claim 1, wherein the trigger assembly comprises:
 - a lever arm extending distally from the trigger, wherein the lever arm comprises a slot;
 - and
 - a leaf spring comprising a free end disposed in the slot;
 - wherein the free end of the leaf spring engages a first portion of the slot when the trigger is in the first actuated position and a second portion of the slot when the trigger is in the second actuated position.

5. The surgical instrument of claim 1, wherein the trigger assembly comprises:
a yoke longitudinally slideable relative to the handle and longitudinally engaging the trigger;
a link arm comprising a slot; and
a trigger pin disposed in the slot, wherein the trigger pin links the trigger and link arm;
wherein the trigger pin engages a first portion of the slot when the trigger is in the first actuated position and a second portion of the slot when the trigger is in the second actuated position.
6. The surgical instrument of claim 1, wherein the trigger assembly comprises:
a yoke longitudinally slideable relative to the handle and longitudinally engaging the trigger, wherein the trigger comprises a cam feature; and
a link arm pivotally attached to a yoke, wherein the link arm comprises a cam follower to engage the cam feature;
wherein the cam follower engages a first portion of the cam feature when the trigger is in the first actuated position and a second portion of the cam feature when the trigger is in the second actuated position.
7. The surgical instrument of claim 1, wherein the trigger assembly comprises:
a trigger comprising a trigger slot and a cam feature comprising a trigger notch;
a link arm pivotally attached to a yoke, wherein the link arm comprises a cam follower to engage the cam feature; and
a trigger pin disposed in the slot, wherein the trigger pin links the trigger and link arm;
wherein the cam follower engages a first portion of the notch when the trigger is in the first actuated position and a second portion of the notch when the trigger is in the second actuated position; and
wherein the trigger pin engages a first portion of the trigger slot when the trigger is in the first actuated position and a second portion of the trigger slot when the trigger is in the second actuated position.

8. The surgical instrument of claim 1, wherein the trigger assembly comprises:
a handle comprising a cam feature comprising a cam slot; and
a link arm pivotally attached to a yoke, wherein the link arm comprises a linkage pin disposed in the cam slot;
a trigger comprising a trigger slot;
a trigger pin disposed in the trigger slot, wherein the trigger pin links the trigger and link arm;
wherein the linkage pin engages a first portion of the cam slot when the trigger is in the first actuated position and a second portion of the cam slot when the trigger is in the second actuated position; and
wherein the trigger pin engages a first portion of the trigger slot when the trigger is in the first actuated position and a second portion of the trigger slot when the trigger is in the second actuated position.
9. The surgical instrument of claim 1, wherein
the handle comprises a cam feature comprising a slot; and
the trigger assembly comprises:
a link arm pivotally attached to the trigger; and
a yoke longitudinally slideable relative to the handle and longitudinally engaging the trigger, wherein the yoke comprises a cam feature comprising a notch, and
a yoke pin comprising a first end disposed in the slot and a second end disposed in the notch;
wherein the first end of the yoke pin engages a first portion of the slot and the second end of the yoke pin engages a first portion of the notch when the trigger is in the first actuated position and the first end of the yoke pin engages a second portion of the slot and the second end of the yoke pin engages a second portion of the notch when the trigger is in the second actuated position.
10. The surgical instrument of claim 9, wherein the trigger assembly provides an audible and/or tactile signal when the link pin engages at least one of the second portion of the slot and second portion of the notch.

11. The surgical instrument of claim 1, wherein the trigger assembly comprises:
 - a yoke longitudinally slideable relative to the handle;
 - a link arm pivotally attached to the yoke and slidingly attached to the trigger, wherein the link arm comprises a cam feature comprising a cam slot;
 - a trigger pin linking the trigger and link arm, wherein the trigger pin is disposed in the cam slot;
 - wherein the trigger pin engages a first portion of the cam slot when the trigger is in the first actuated position and a second portion of the cam slot when the trigger is in the second actuated position.

12. The surgical instrument of claim 1, wherein the end effector comprises:
 - a first jaw;
 - a second jaw, wherein at least one of the first jaw and second jaw is movable relative to the other of the first jaw and second jaw between an open position and a closed position; and
 - at least one electrode to apply electrosurgical energy to weld tissue.

13. The surgical instrument of claim 12, wherein the at least one electrode is coupled to a radiofrequency (Rf) energy source.

14. The surgical instrument of claim 13 comprising a lockout mechanism to prevent current from flowing from the energy source to the at least one electrode unless the trigger is in the second actuated position.

15. The electrosurgical instrument of claim 12, wherein one of the first jaw and second jaw is longitudinally movable between a first position and a second position relative to the other of the first jaw and second jaw, wherein the one of the first jaw and second jaw is in the first position when the trigger is in the unactuated position and the second position when the trigger is in the first actuated position.

16. The surgical instrument of claim 1, wherein the end effector comprises a firing beam longitudinally movable along at least a portion of the end effector, wherein the firing beam comprises:

a distal blade to sever tissue, wherein the distal blade comprises opposing surfaces each comprising at least one roller bearing to compress tissue.

17. A surgical instrument, comprising:

a shaft comprising a proximal end and a distal end;

an end effector extending from the distal end of the shaft, wherein the end effector comprises a first jaw, a second jaw, and an electrode, wherein the first jaw is movable relative to the second jaw between an open position and a closed position to compress tissue intermediate the first jaw and second jaw when in the closed position;

a handle extending from the proximal end, wherein the handle comprises a gripping portion; and

a trigger assembly extending from the handle, wherein the trigger assembly comprises a trigger movable relative to the gripping portion through a first range of motion from an unactuated position to a first actuated position, wherein the trigger is movable through a second range of motion from first actuated position to a second actuated position, and wherein the trigger is movable through a third range of motion from the second actuated position to the unactuated position, wherein the trigger is operable to control the end effector to selectively compress tissue at a first compressive force when the trigger is in the first actuated position and a second compressive force when the trigger is in the second actuated position, wherein the first compressive force is greater than the second compressive force.

18. The surgical instrument of claim 17 comprising a cam feature and an engagement member to engage the cam feature, wherein the engagement member engages a first portion of the cam feature when the trigger is in the first actuated position and a second portion of the cam feature when the trigger is in the second actuated position.

19. A surgical instrument, comprising:
a shaft comprising a proximal end and a distal end;
an ultrasonic waveguide at least partially positioned within the shaft, the waveguide having a proximal end and a distal end;
an ultrasonically actuated blade positioned at the distal end of the waveguide;
a clamp arm assembly pivotally connected to the distal end of the shaft, wherein the clamp arm assembly comprises at least two camming members rotationally attached to a clamp arm, wherein the clamp arm is movable between an open position and a closed position relative to the blade to compress tissue intermediate the clamp arm and blade when in the closed position, and wherein the at least two camming members rotate relative to the clamp arm to separate tissue layers when the clamp arm moves between the open position and a closed position.
20. The surgical instrument of claim 19, wherein the at least two camming members selectively compress tissue at a first rolling compressive force when a first portion of the camming member contacts tissue and a second rolling compressive force when a second portion of the camming member contacts tissue, wherein the first rolling compressive force is different from the second rolling compressive force.
21. The surgical instrument of claim 20, wherein the first rolling compressive force is greater than the second rolling compressive force.
22. The surgical instrument of claim 21, wherein the at least two camming members each comprise a circumferential surface comprising a first portion and a second portion, wherein the second portion comprises a protrusion, and wherein the protrusion compresses tissue at the first rolling compressive force.
23. The surgical instrument of claim 19, wherein the at least two camming members independently rotate relative to each other when the clamp arm moves between the open position and closed position.

24. The surgical instrument of claim 19, wherein the at least two camming members simultaneously rotate relative to each other when the clamp arm moves between the open position and closed position.

25. The surgical instrument of claim 19, wherein the at least two camming members rotate in one of the same direction and opposite direction when the clamp arm moves between the open position and closed position.

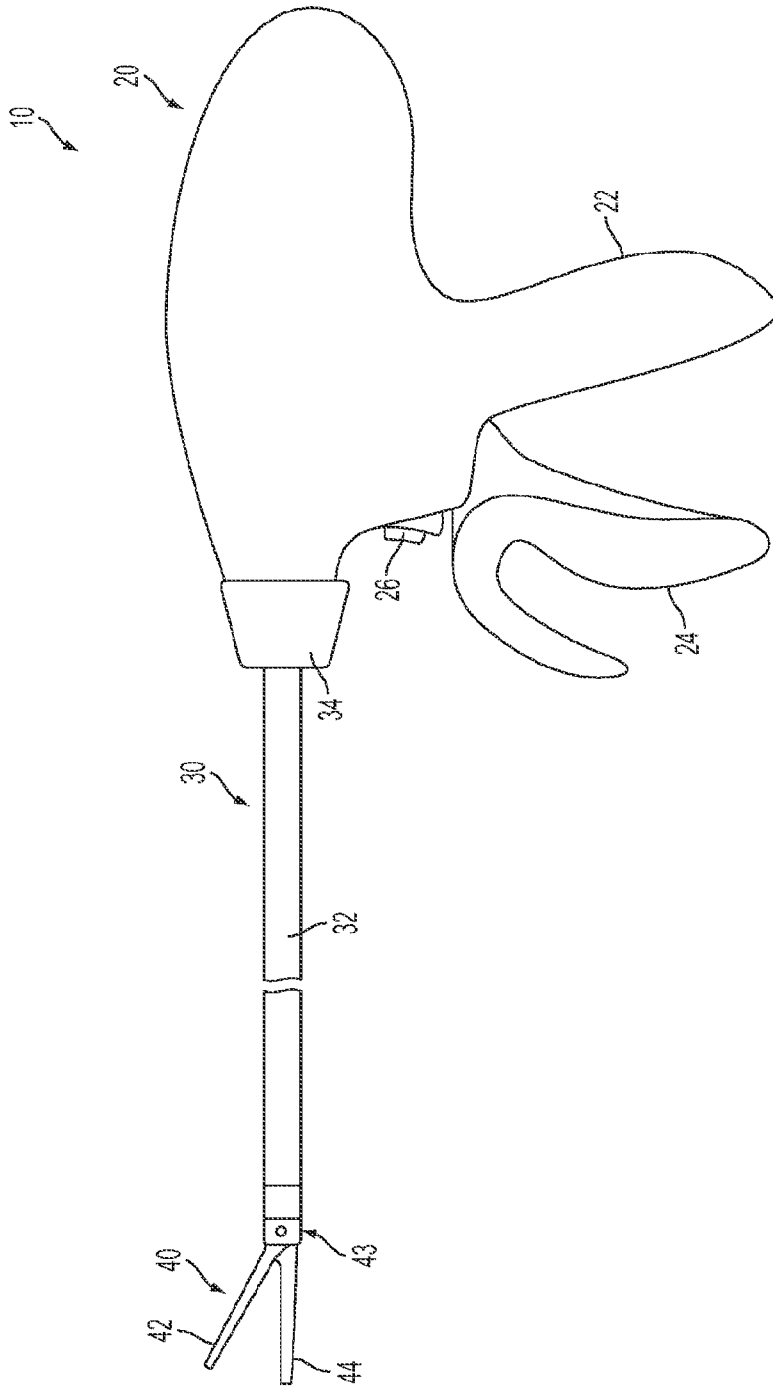

FIG. 1

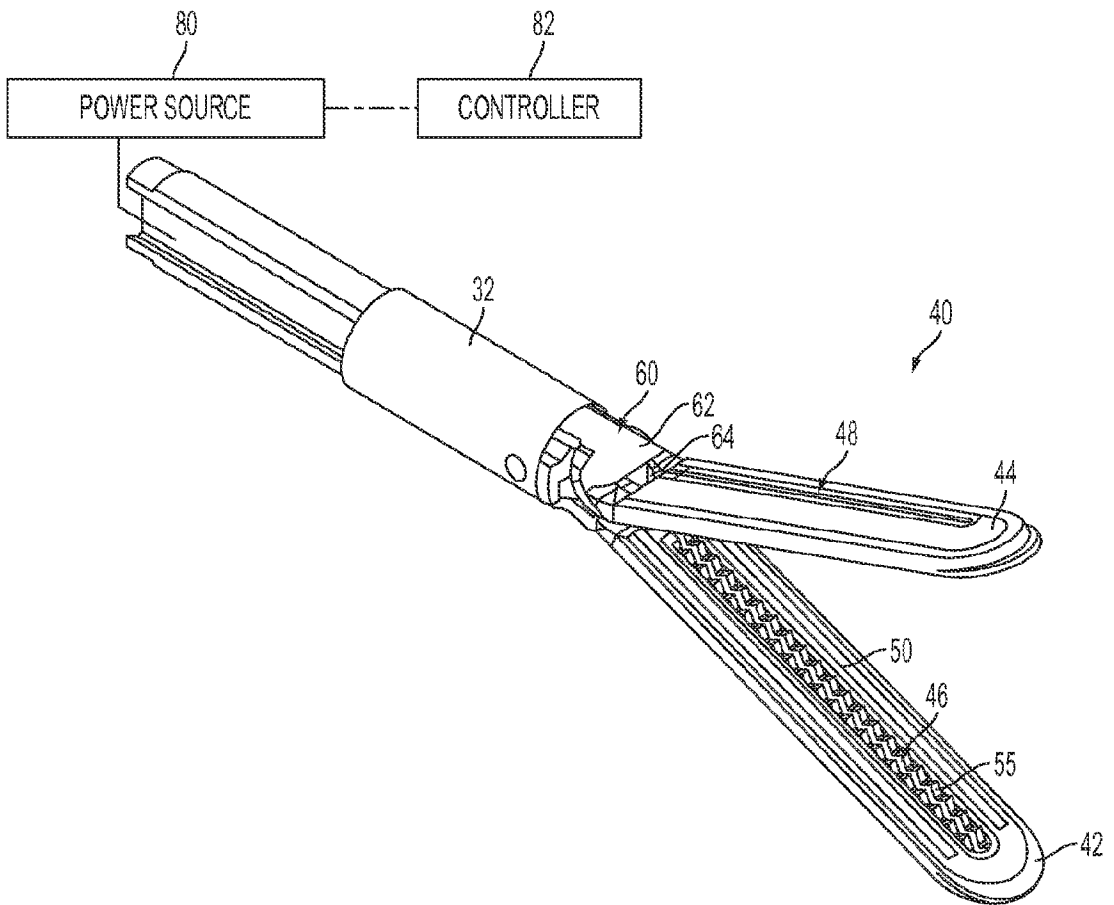

FIG. 2

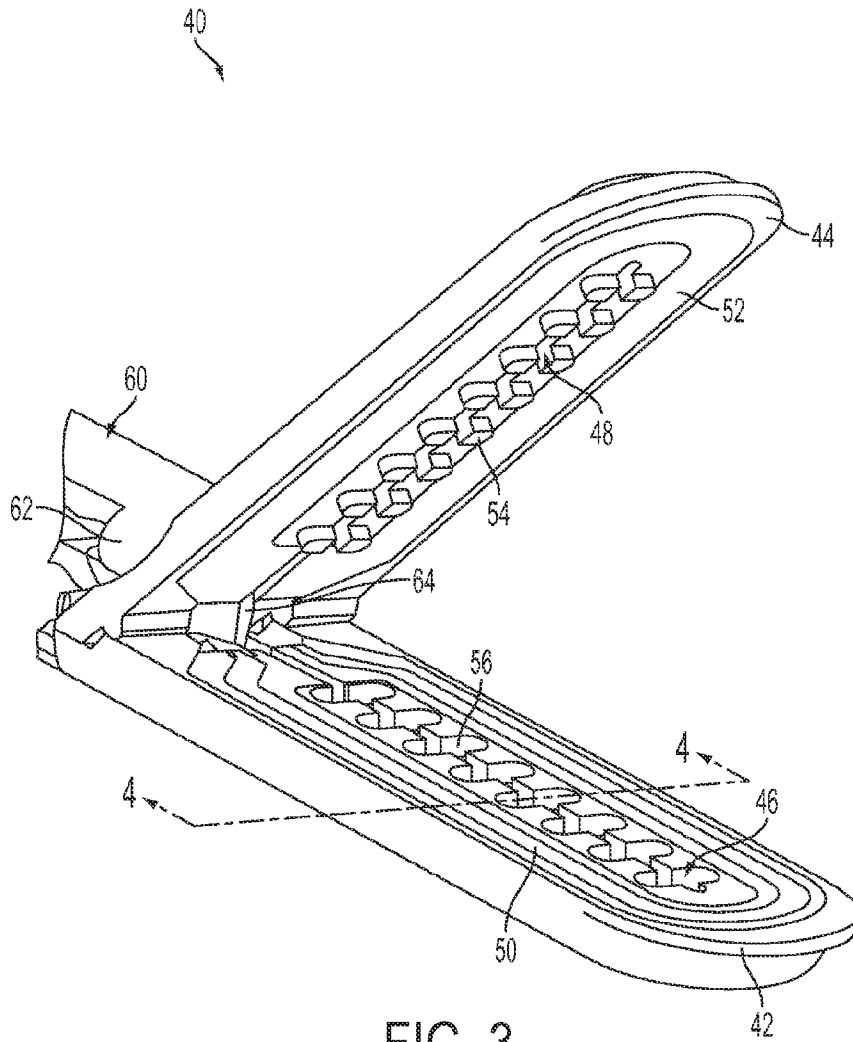

FIG. 3

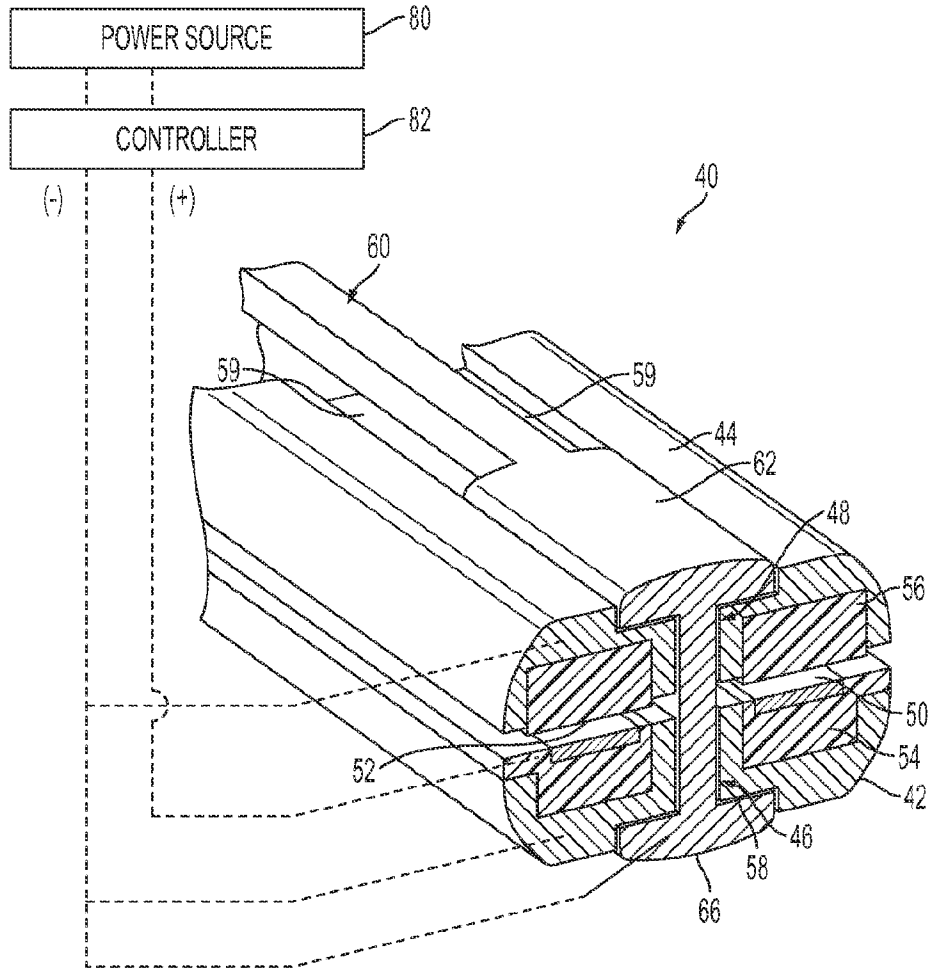

FIG. 4

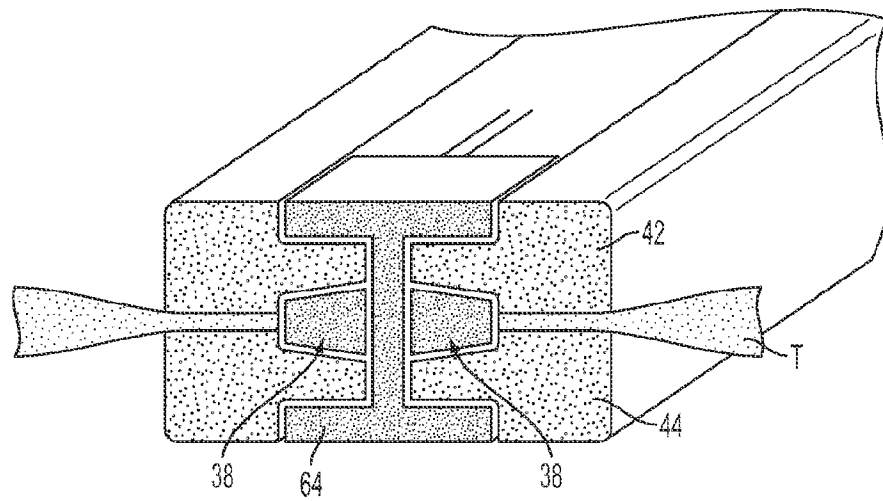

FIG. 4A

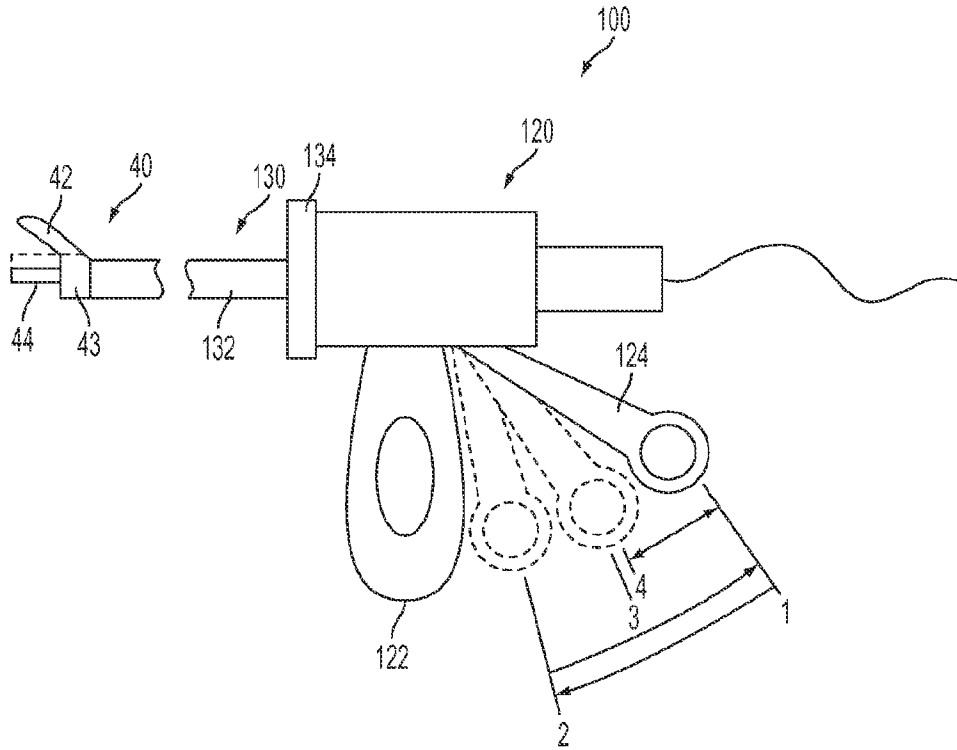

FIG. 5

7/42

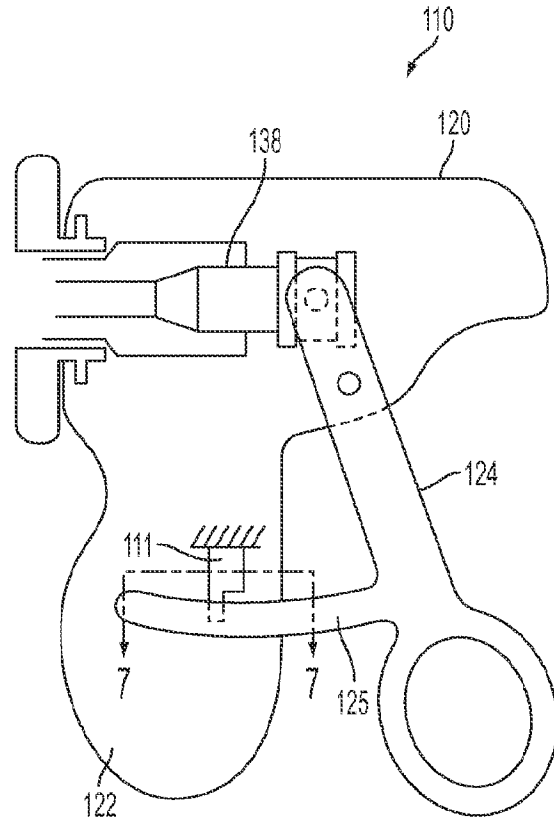

FIG. 6

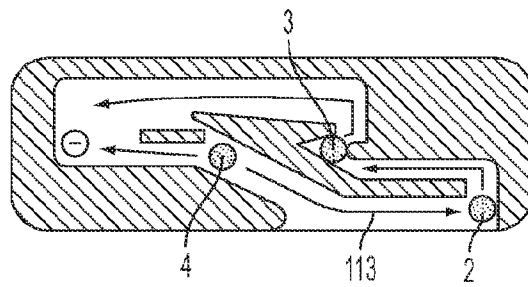

FIG. 7

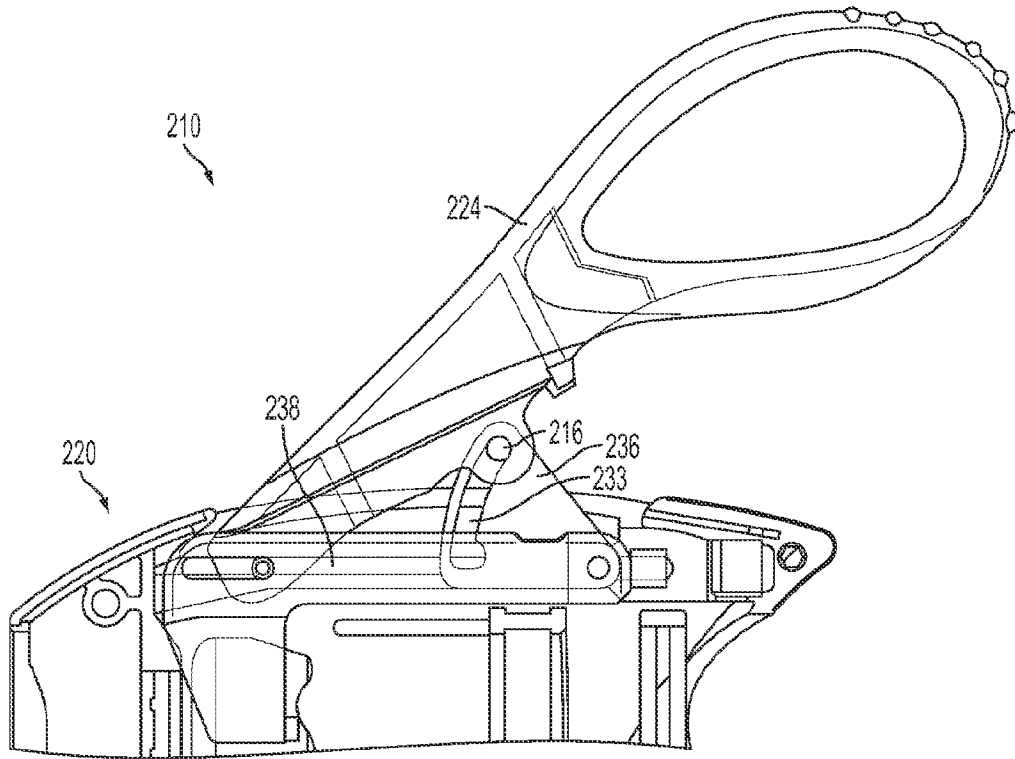

FIG. 8A

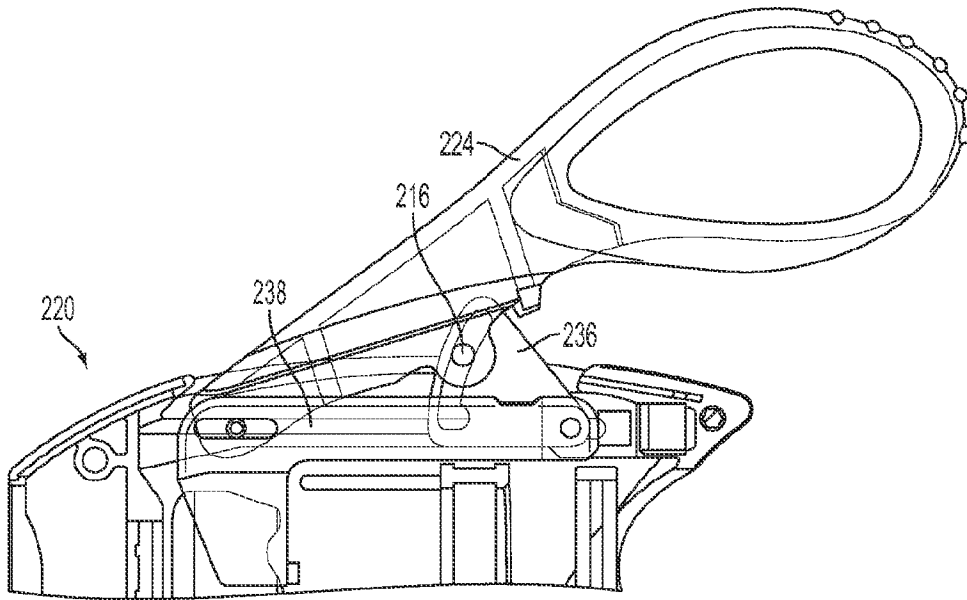

FIG. 8B

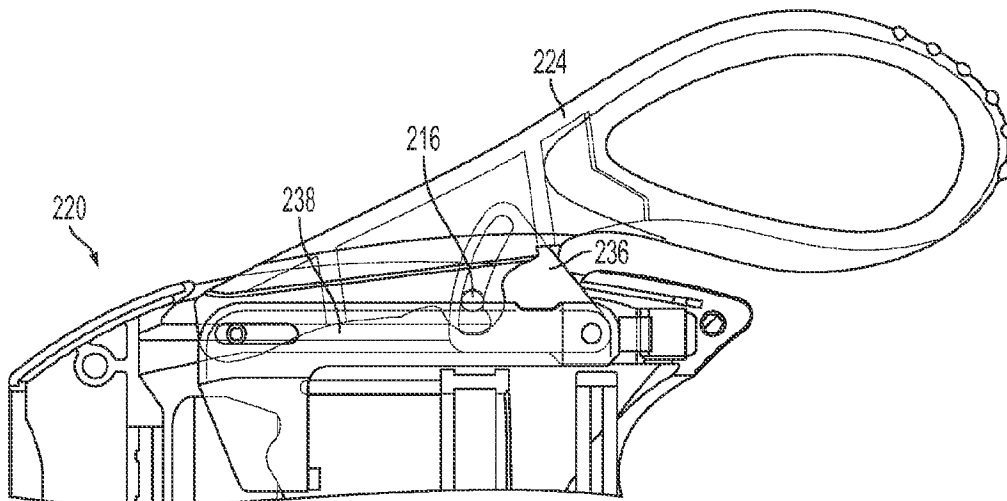

FIG. 8C

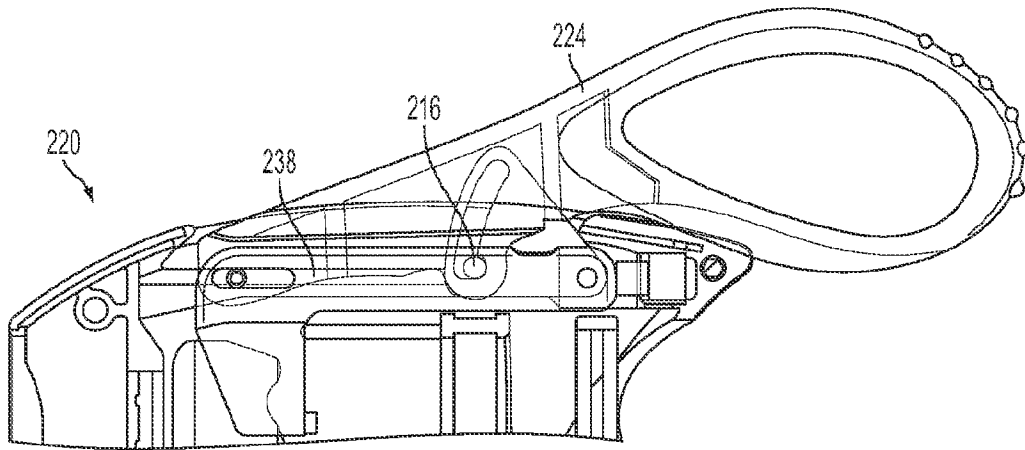

FIG. 8D

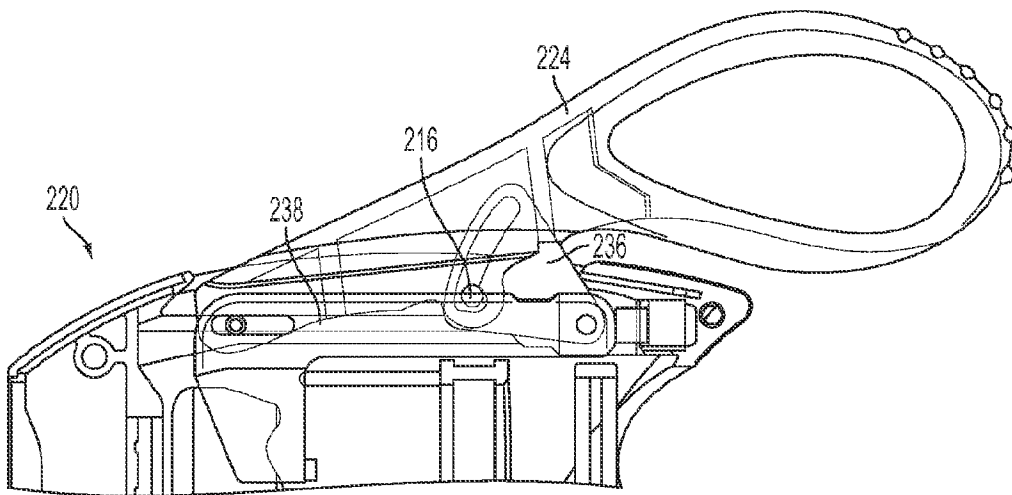

FIG. 8E

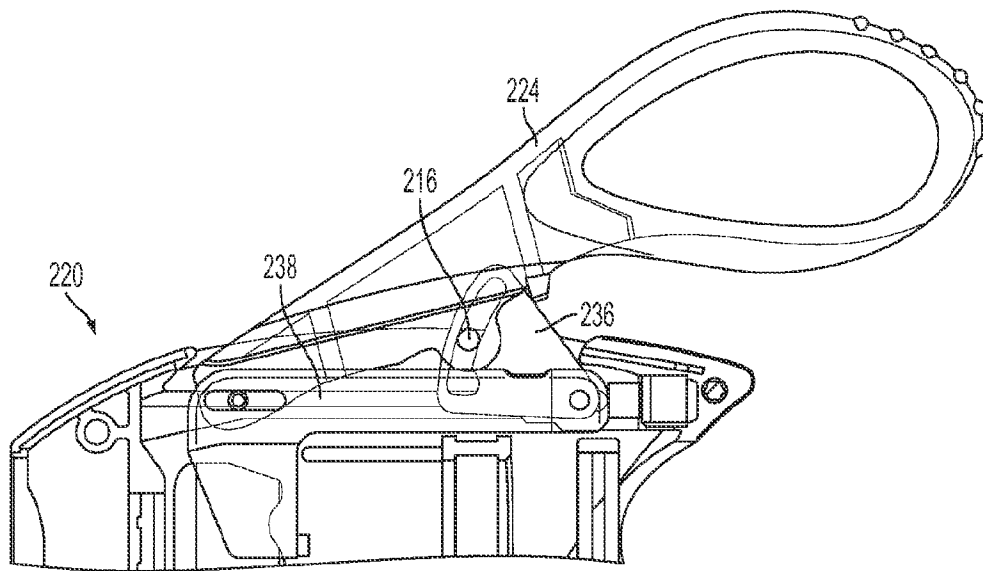

FIG. 8F

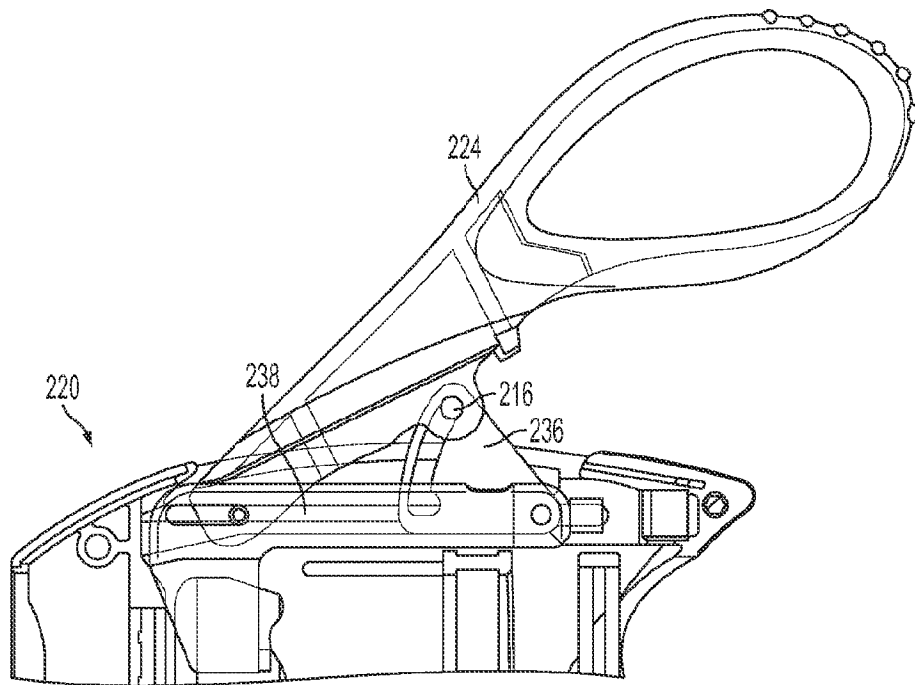

FIG. 8G

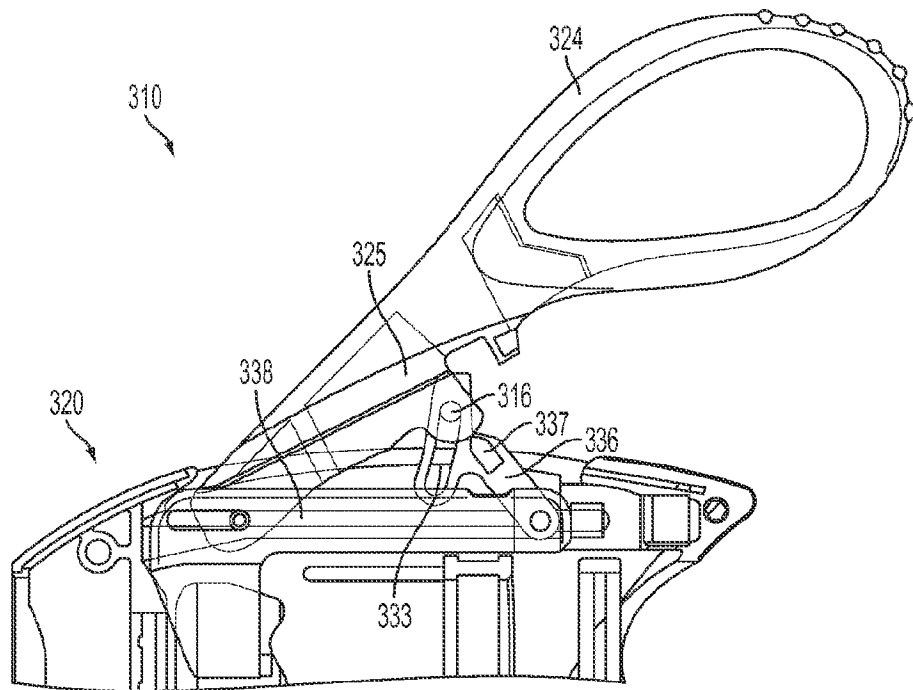

FIG. 9A

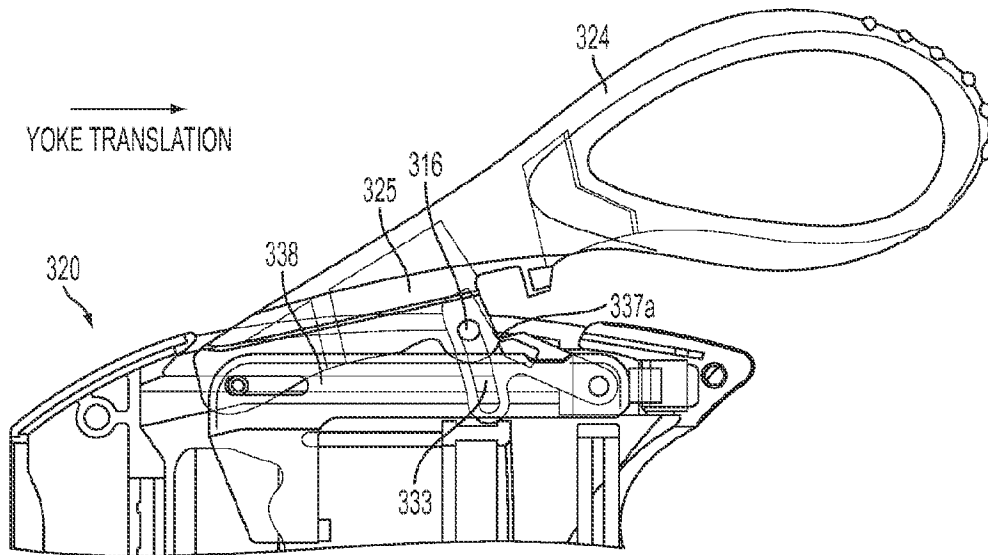

FIG. 9B

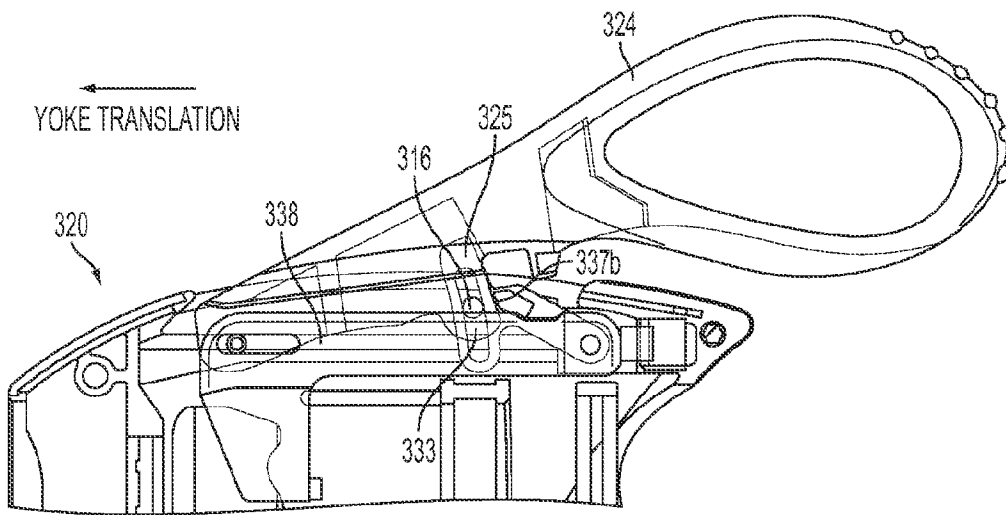

FIG. 9C

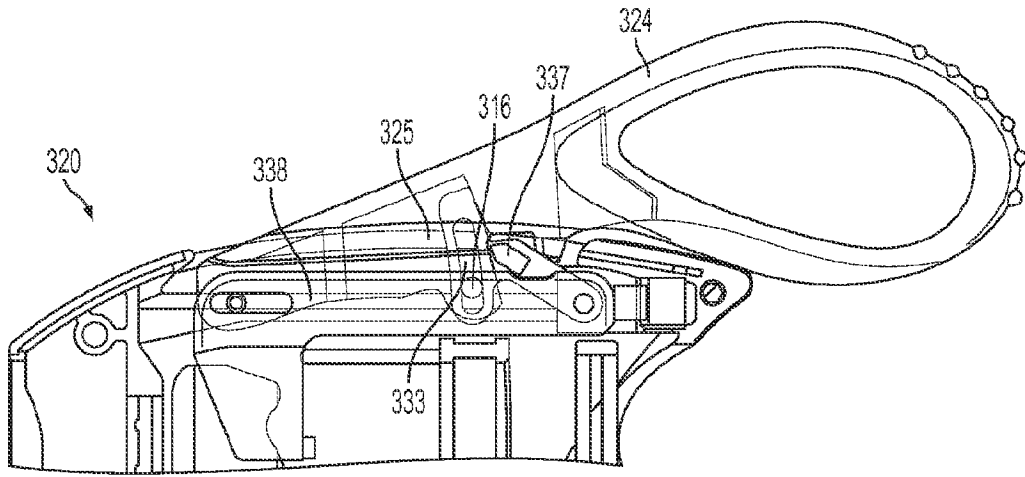

FIG. 9D

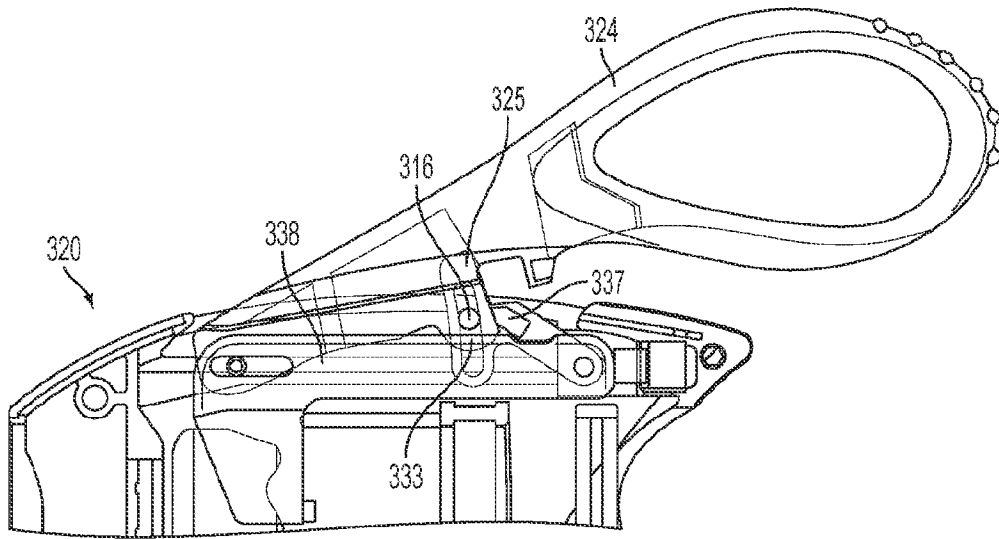

FIG. 9E

16/42

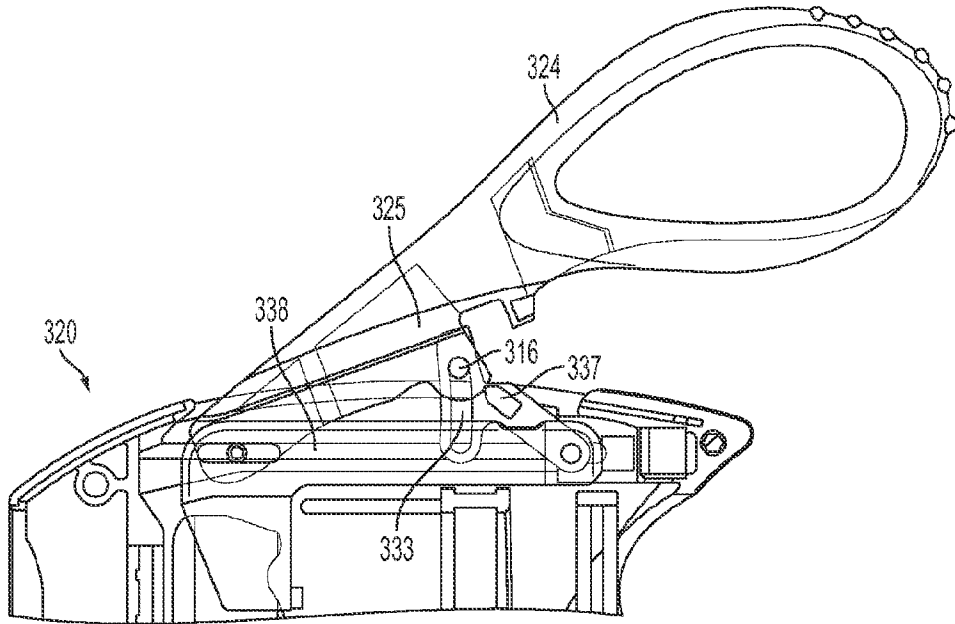

FIG. 9F

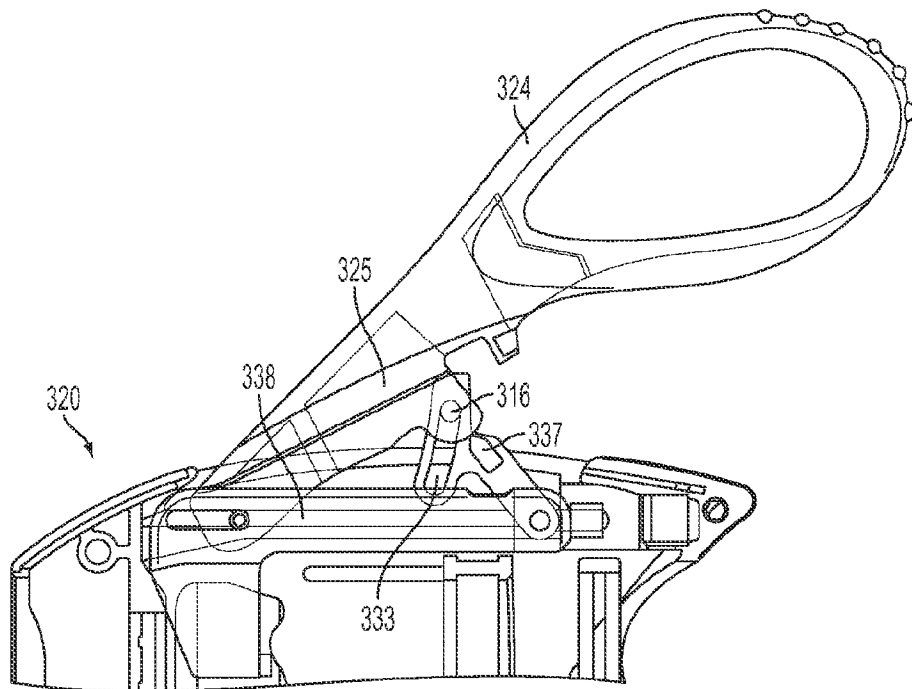

FIG. 9G

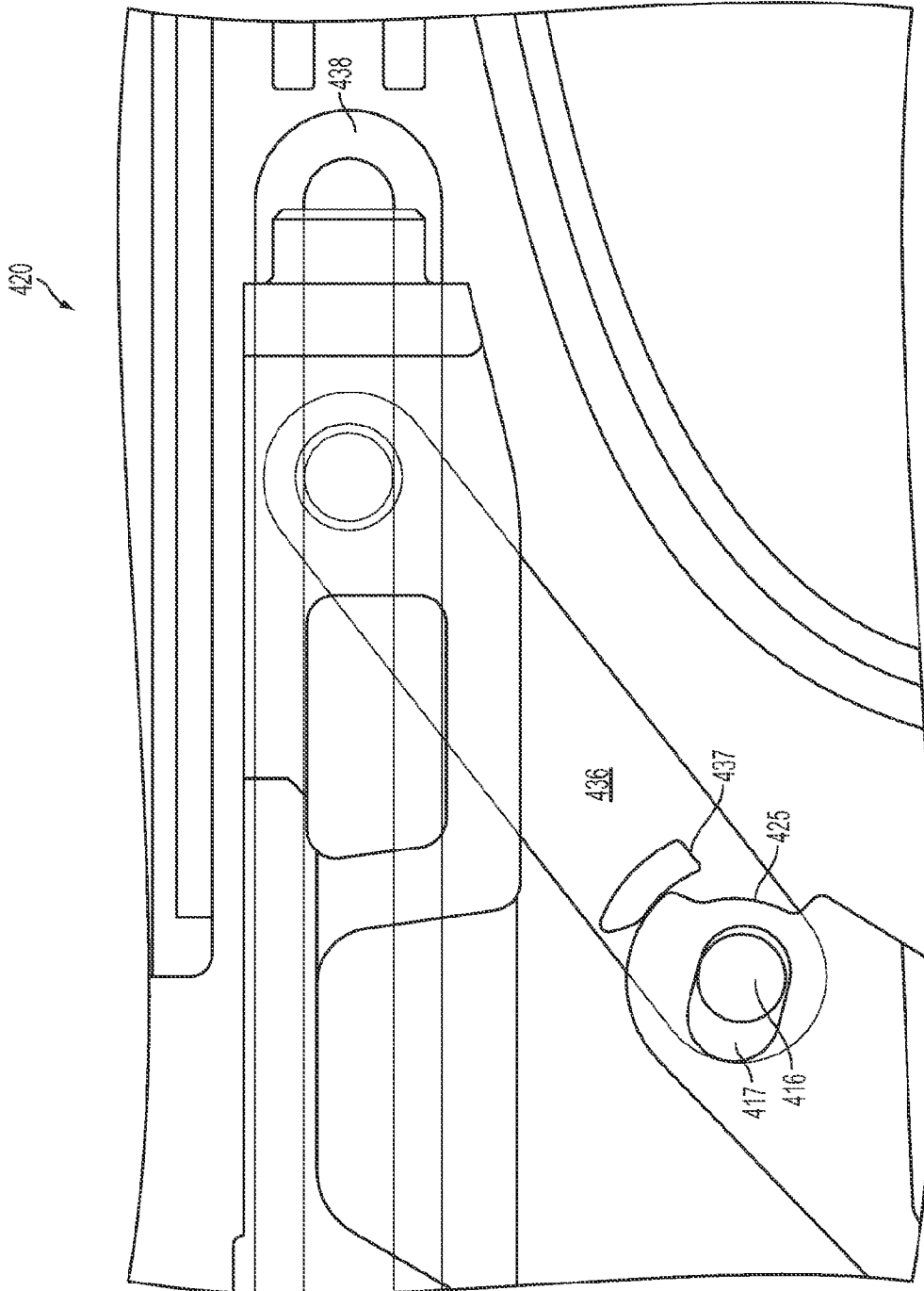

FIG. 10A

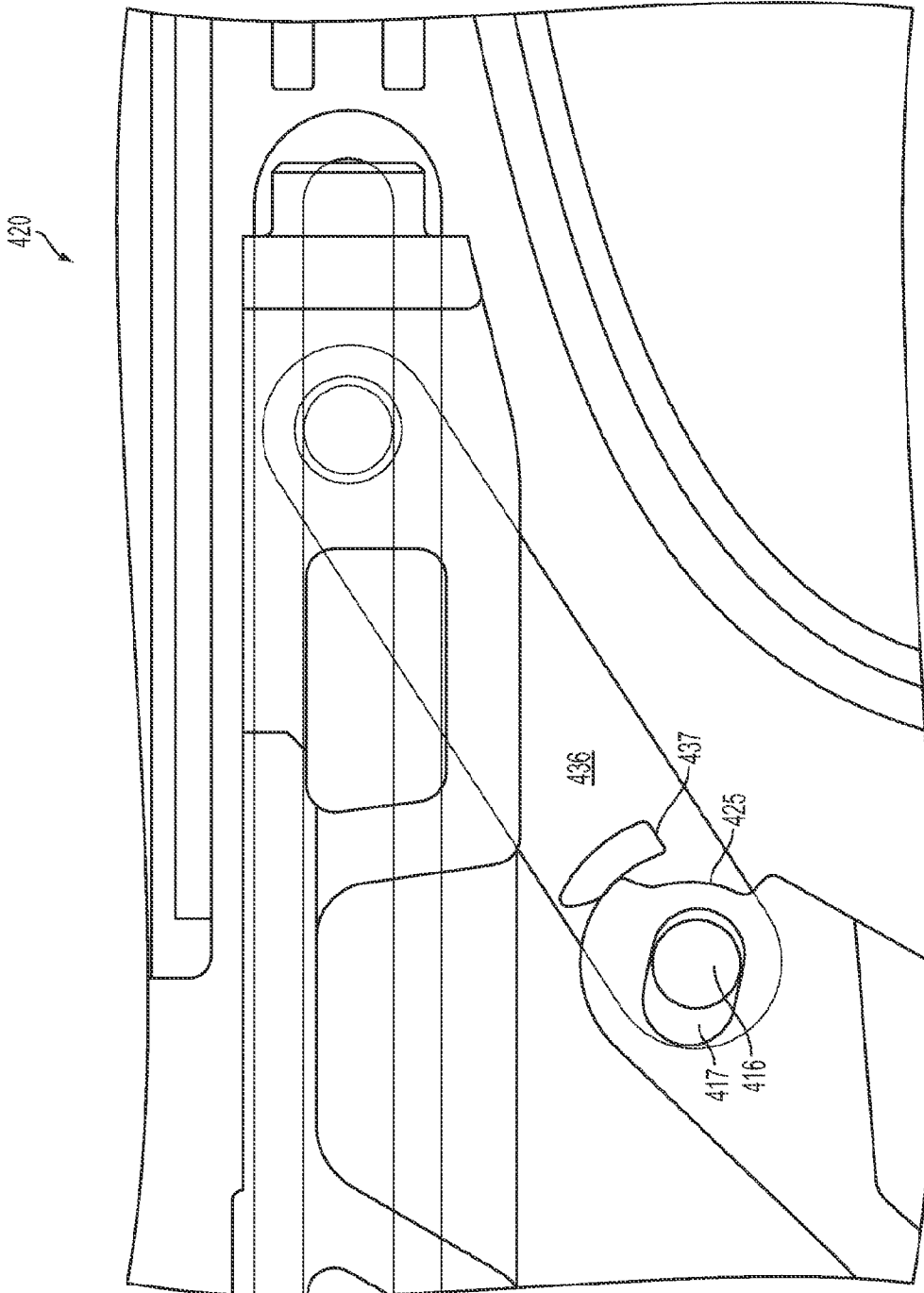

FIG. 10B

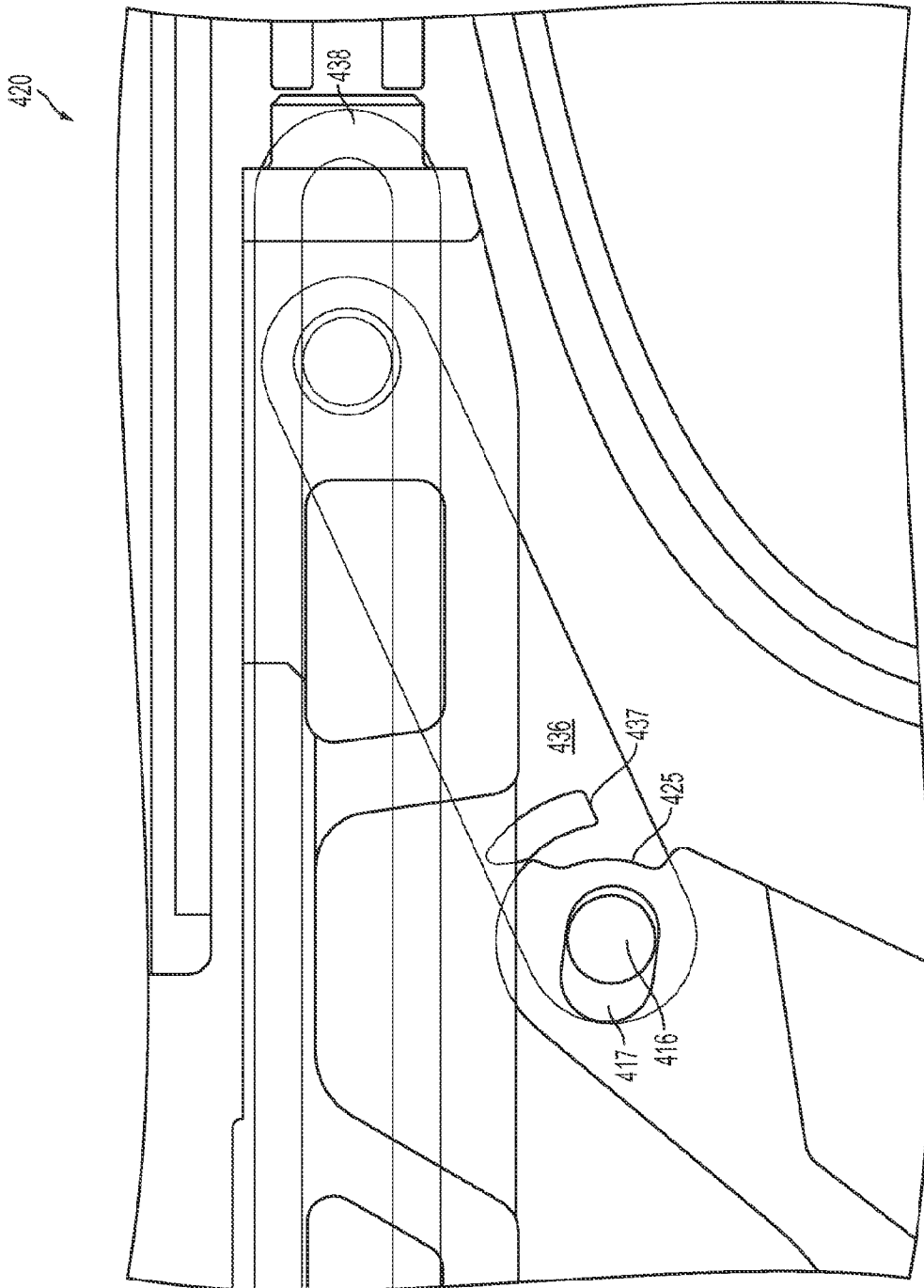

FIG. 10C

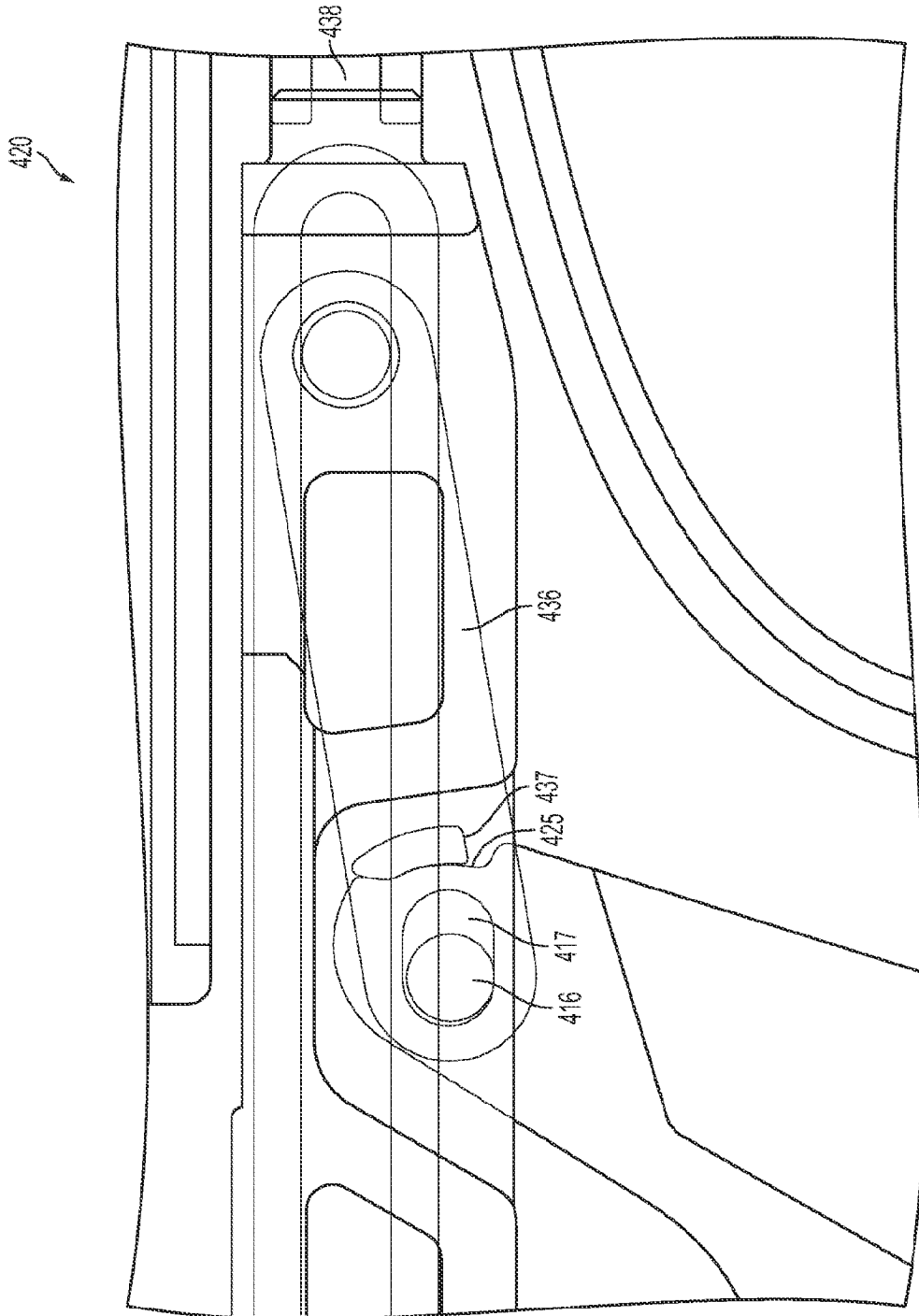

FIG. 10D

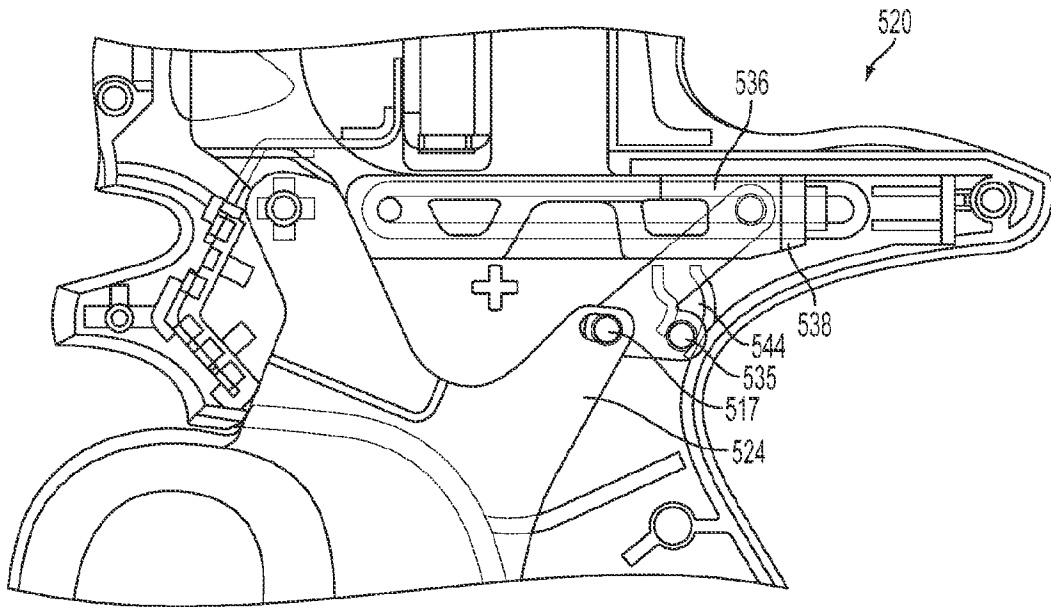

FIG. 11A

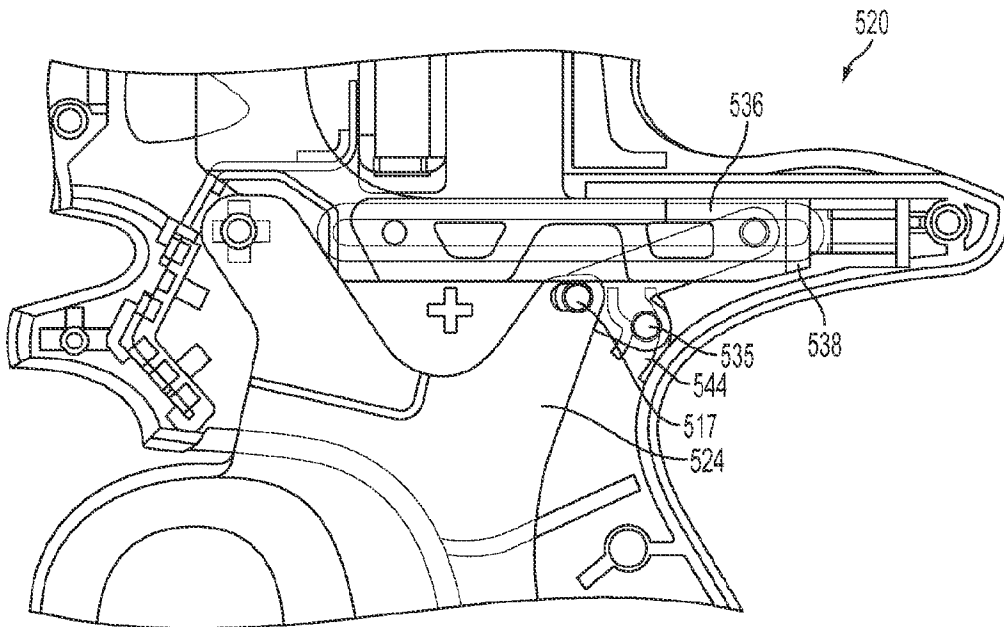

FIG. 11B

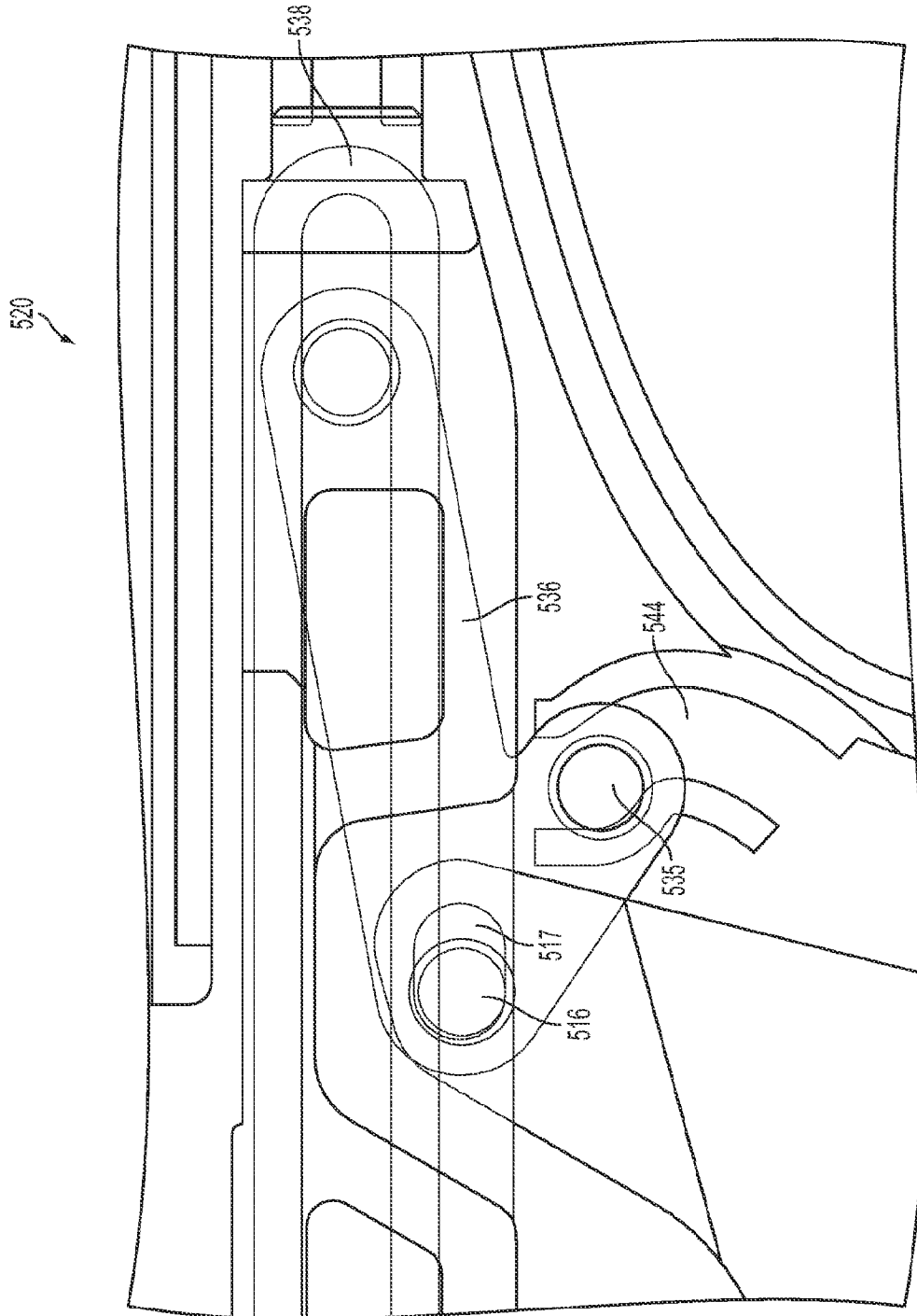

FIG. 11C

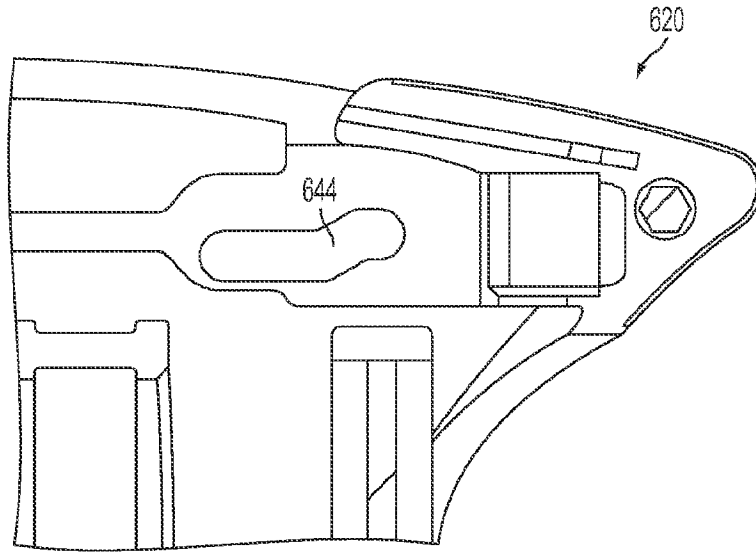

FIG. 12

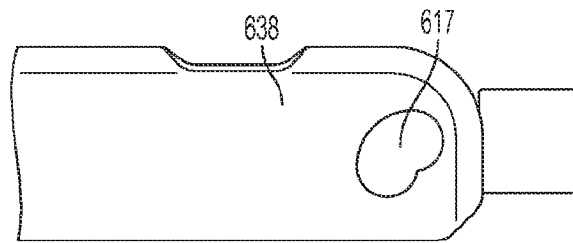

FIG. 13

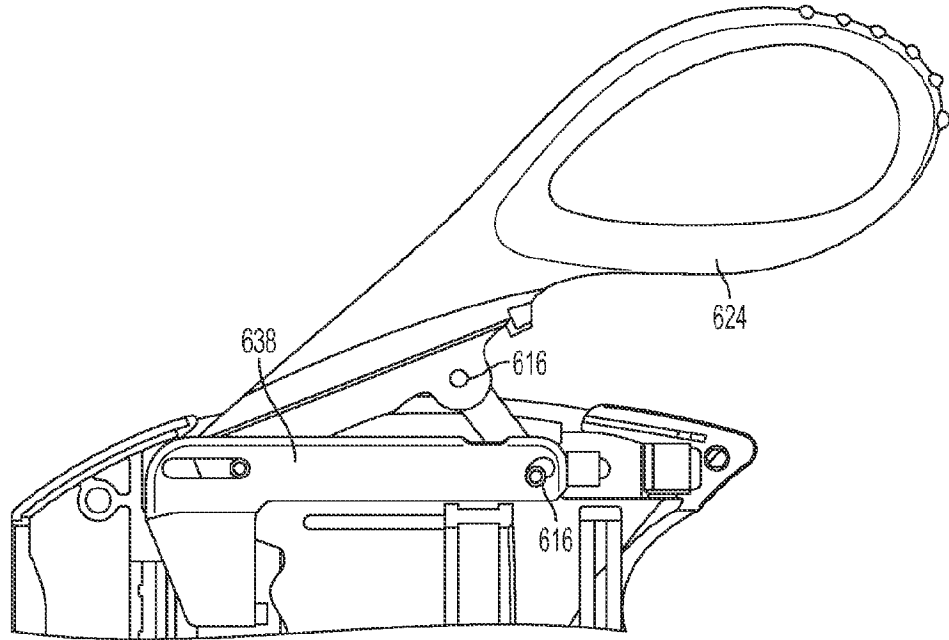

FIG. 14A

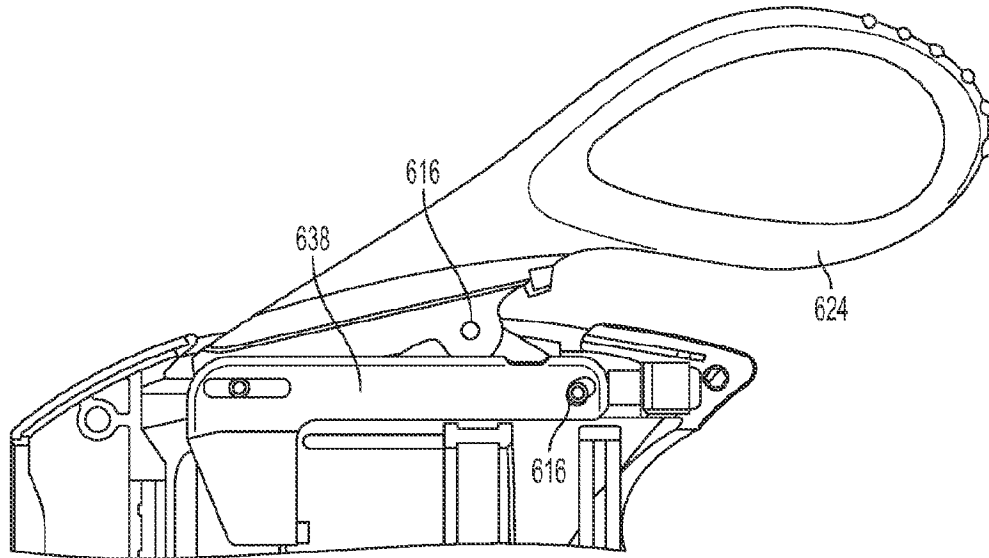

FIG. 14B

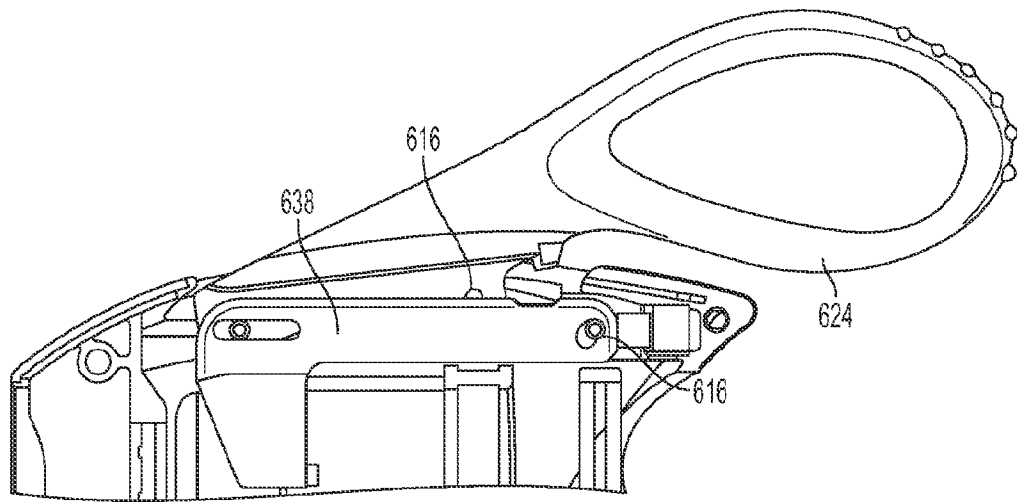

FIG. 14C

26/42

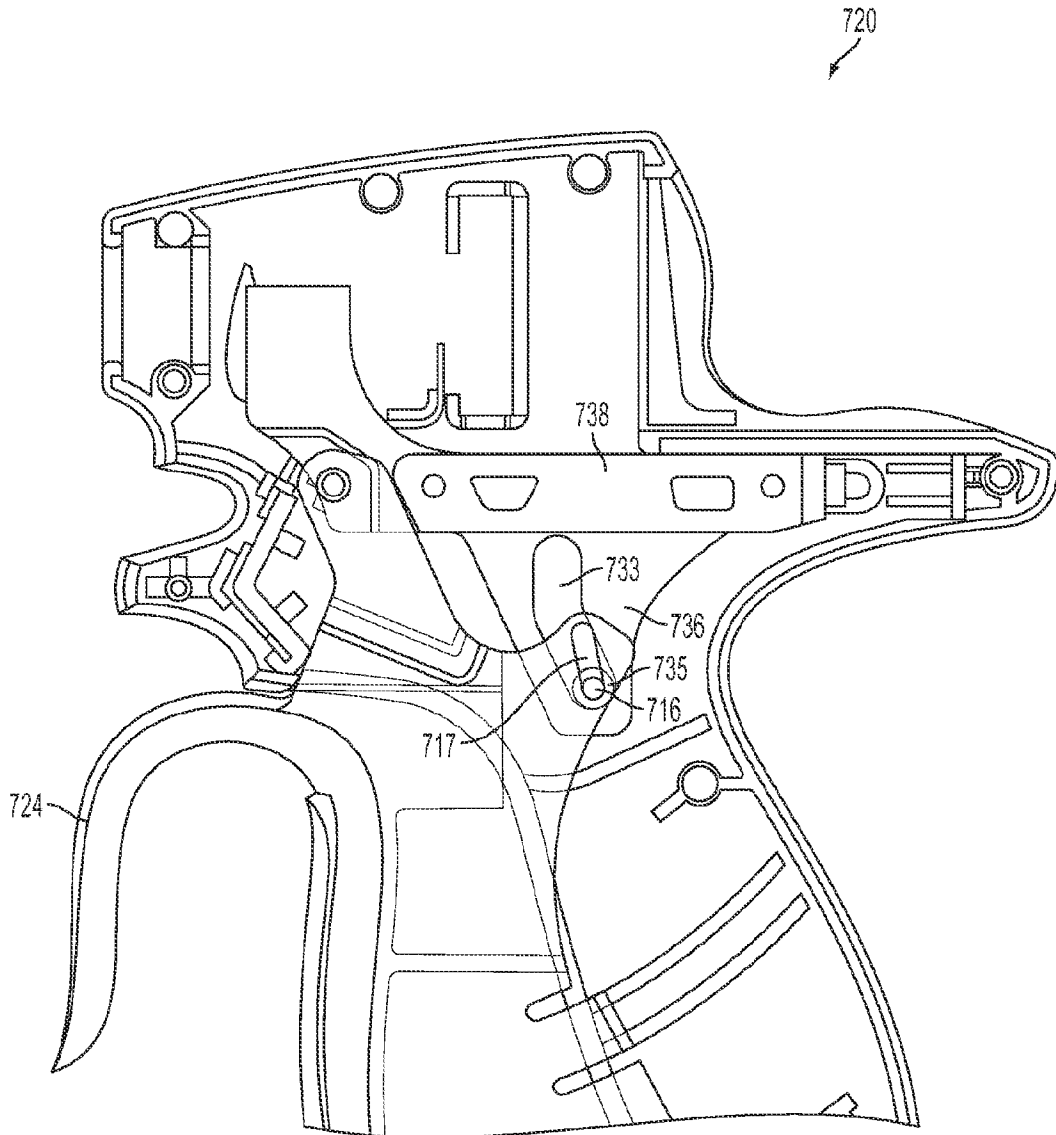

FIG. 15A

27/42

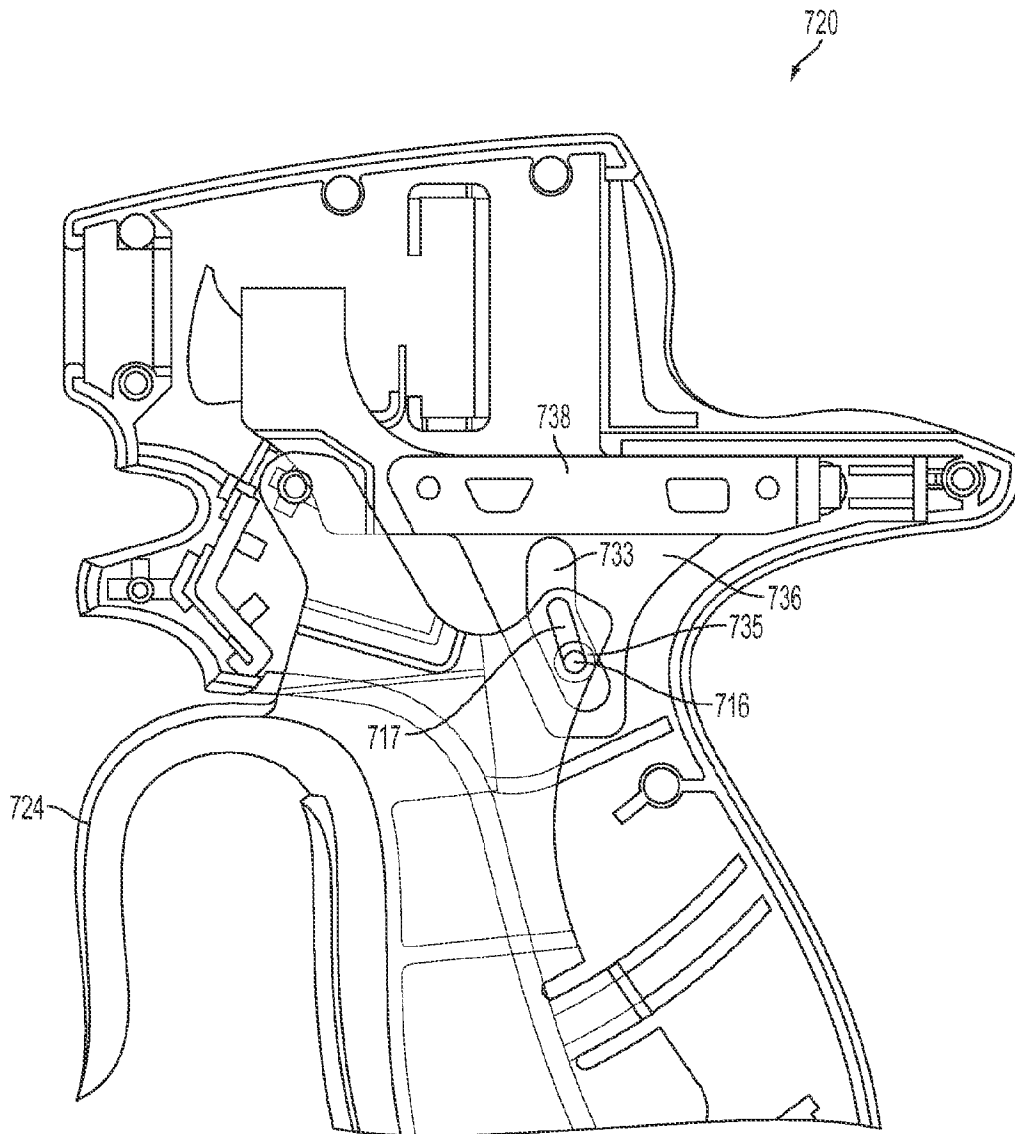

FIG. 15B

28/42

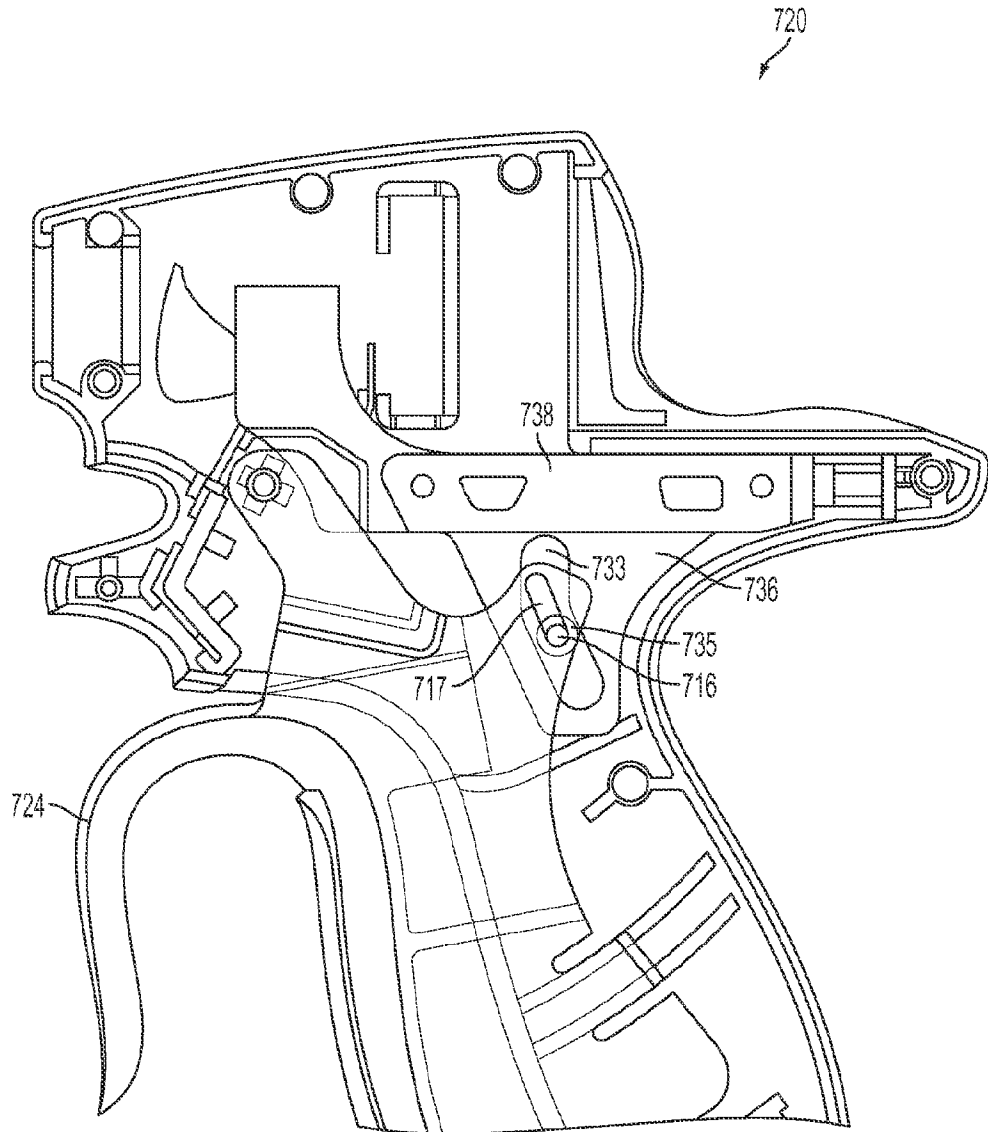

FIG. 15C

29/42

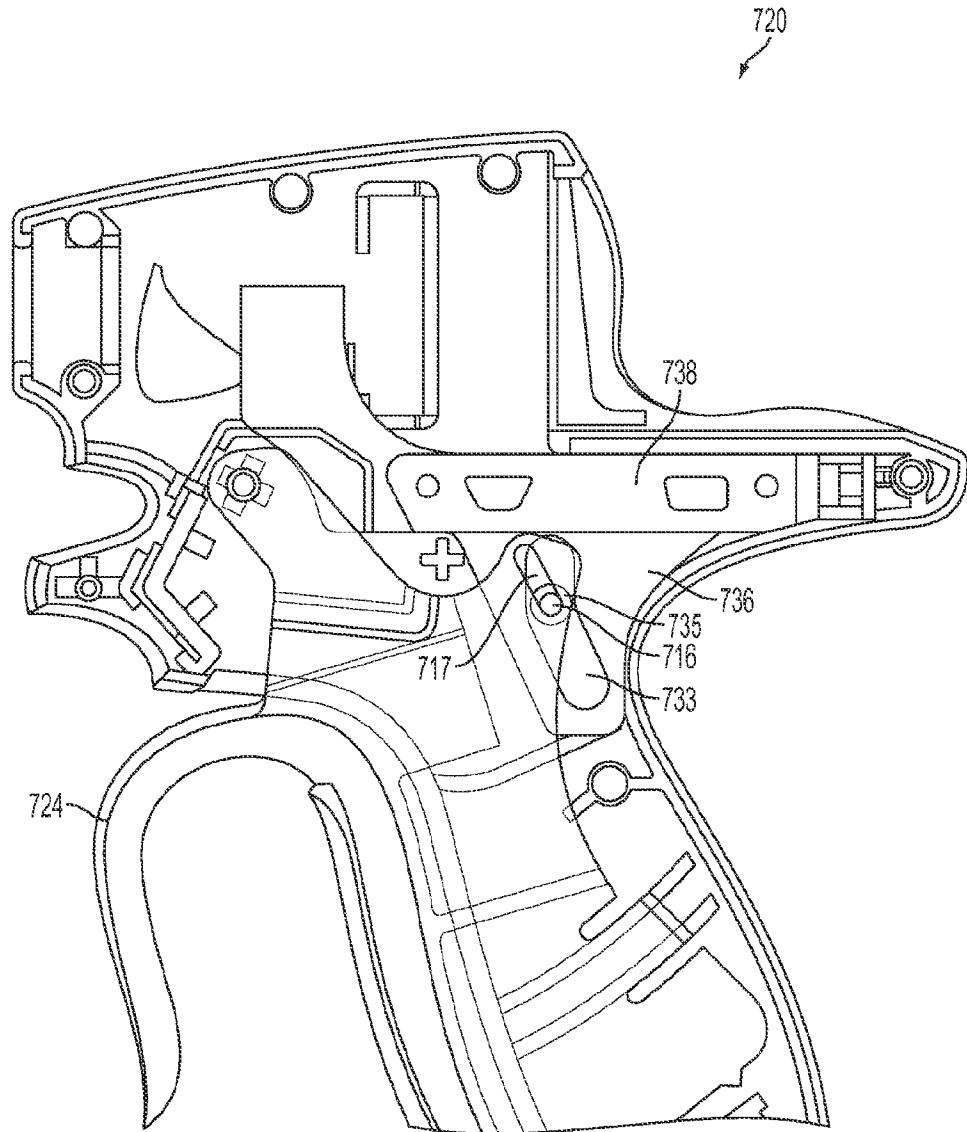

FIG. 15D

30/42

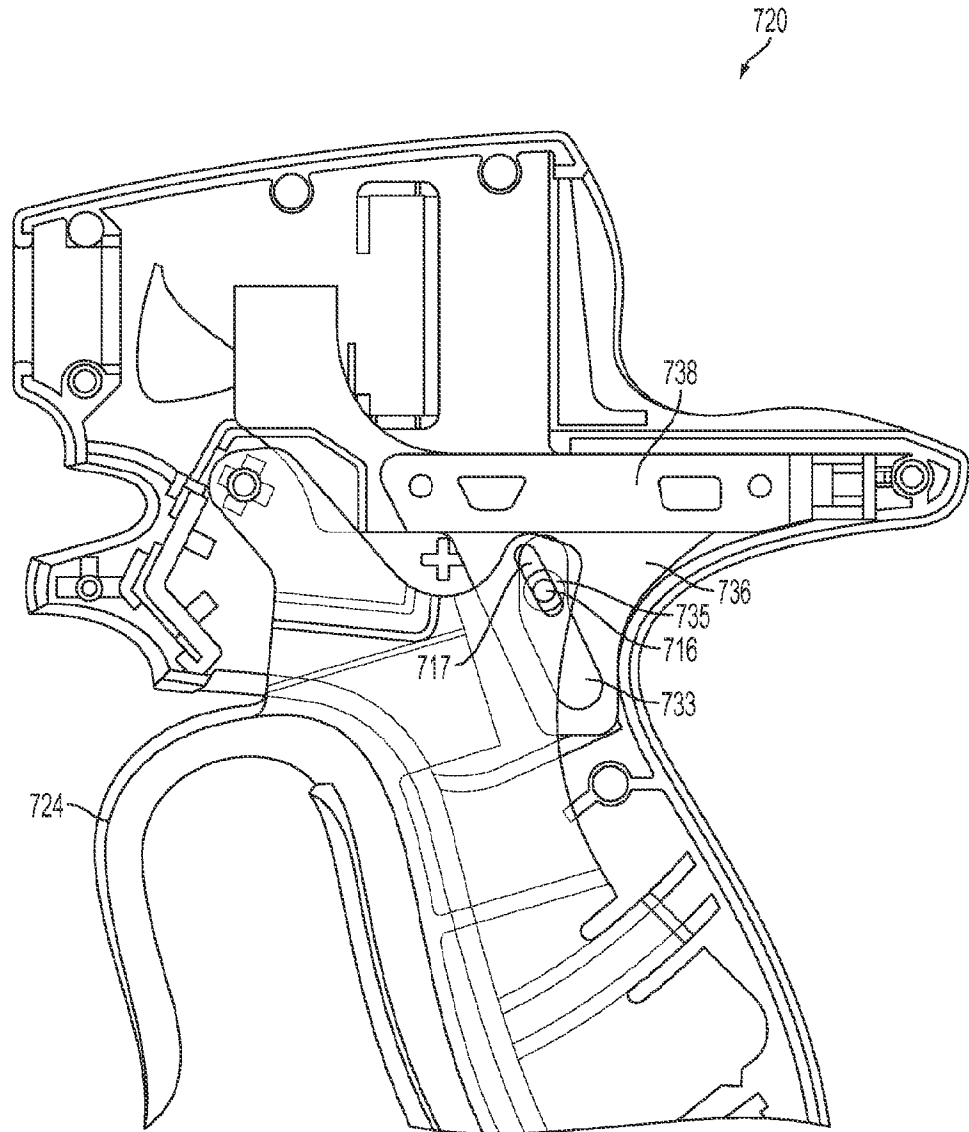

FIG. 15E

31/42

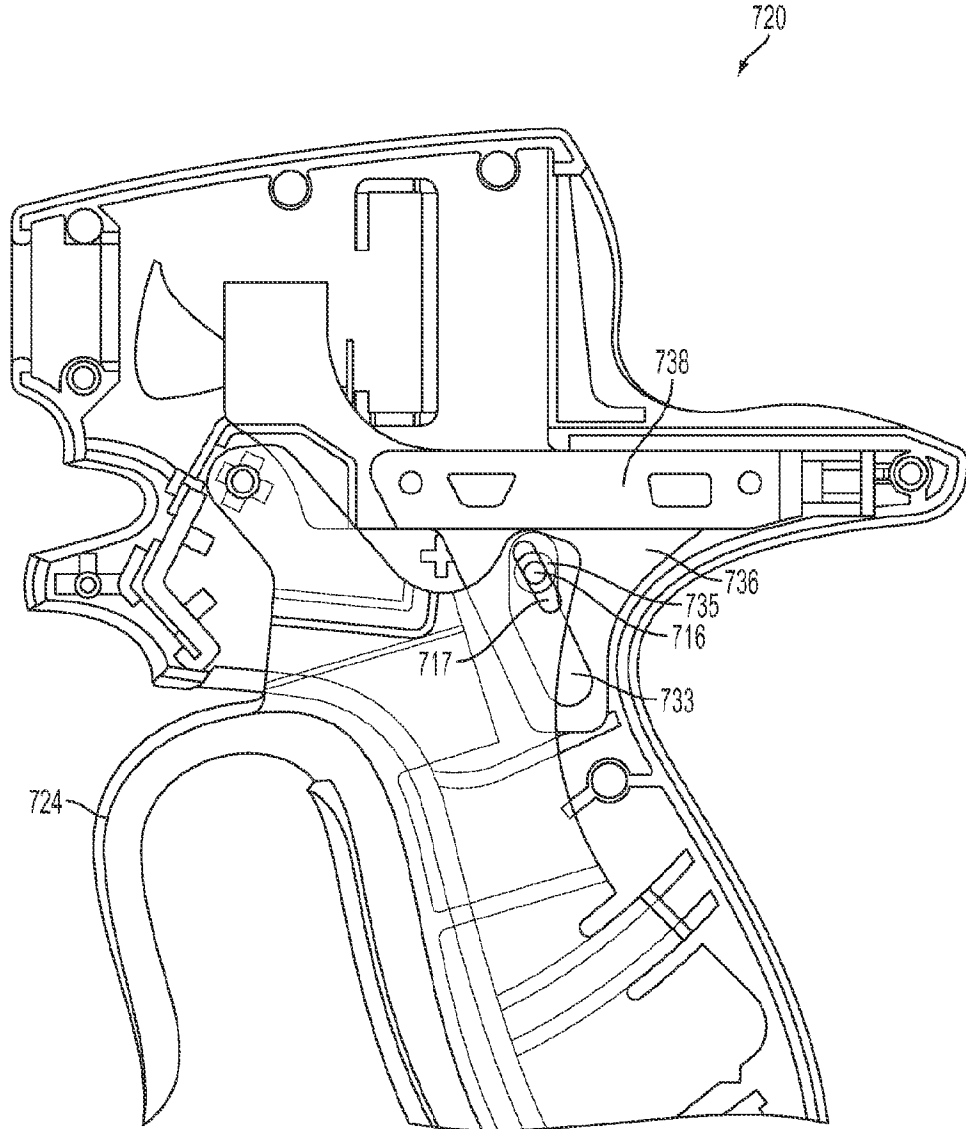

FIG. 15F

32/42

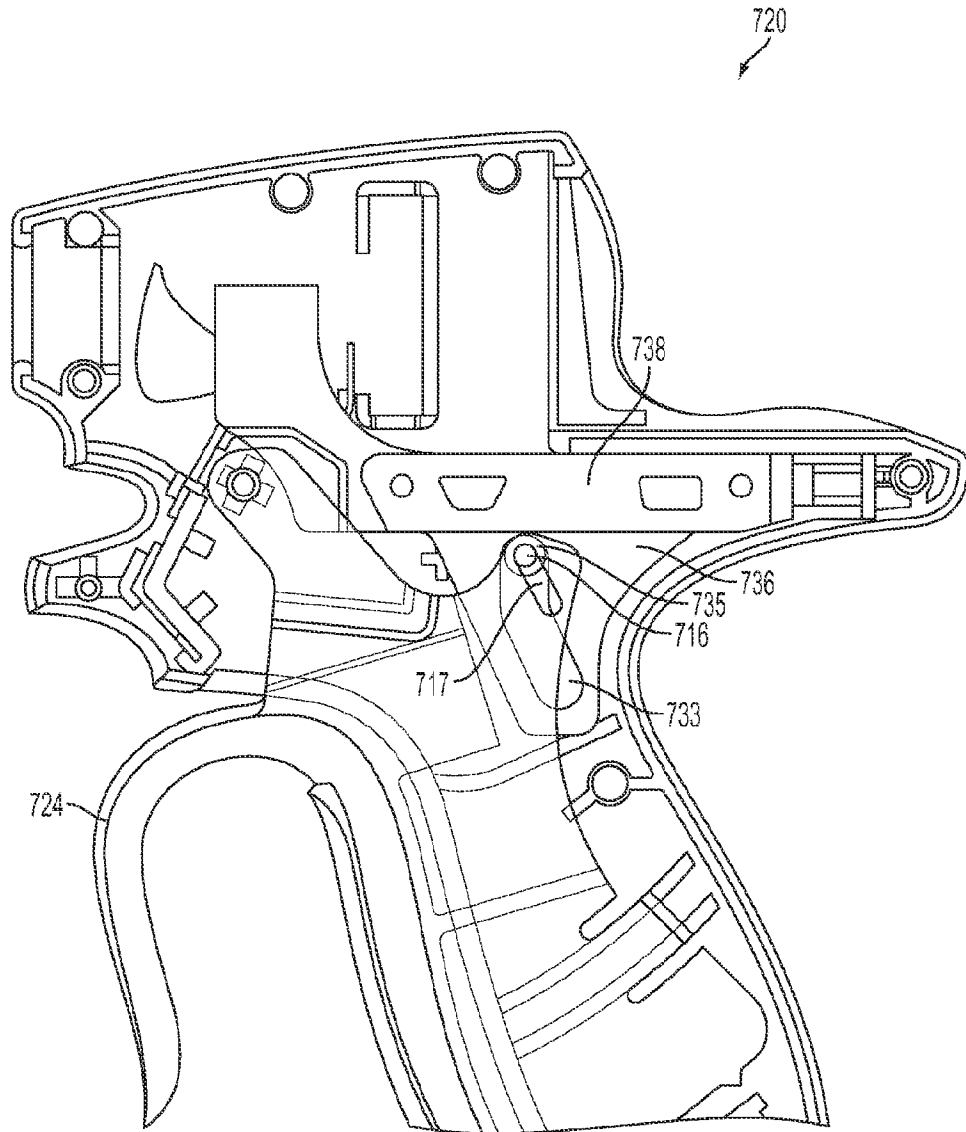

FIG. 15G

33/42

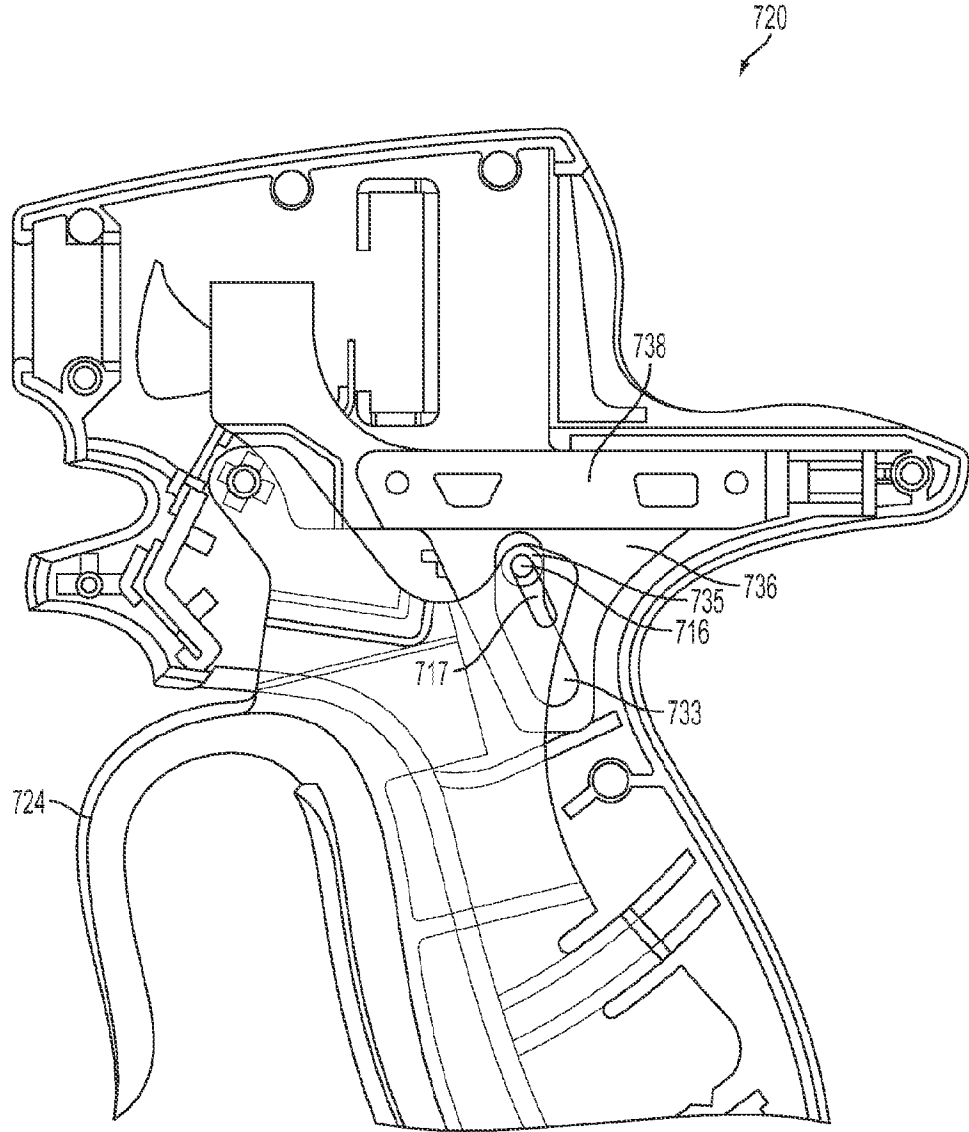

FIG. 15H

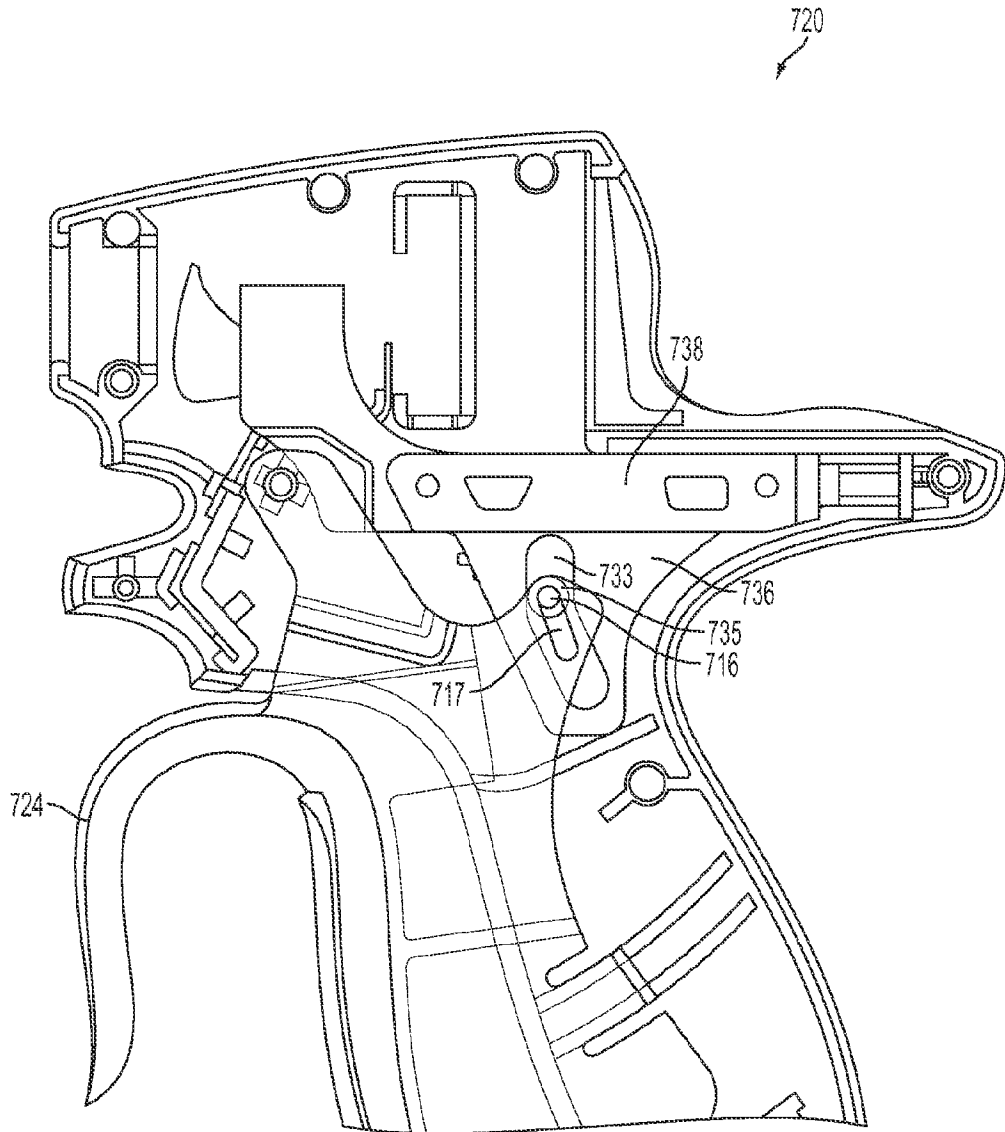

FIG. 15I

35/42

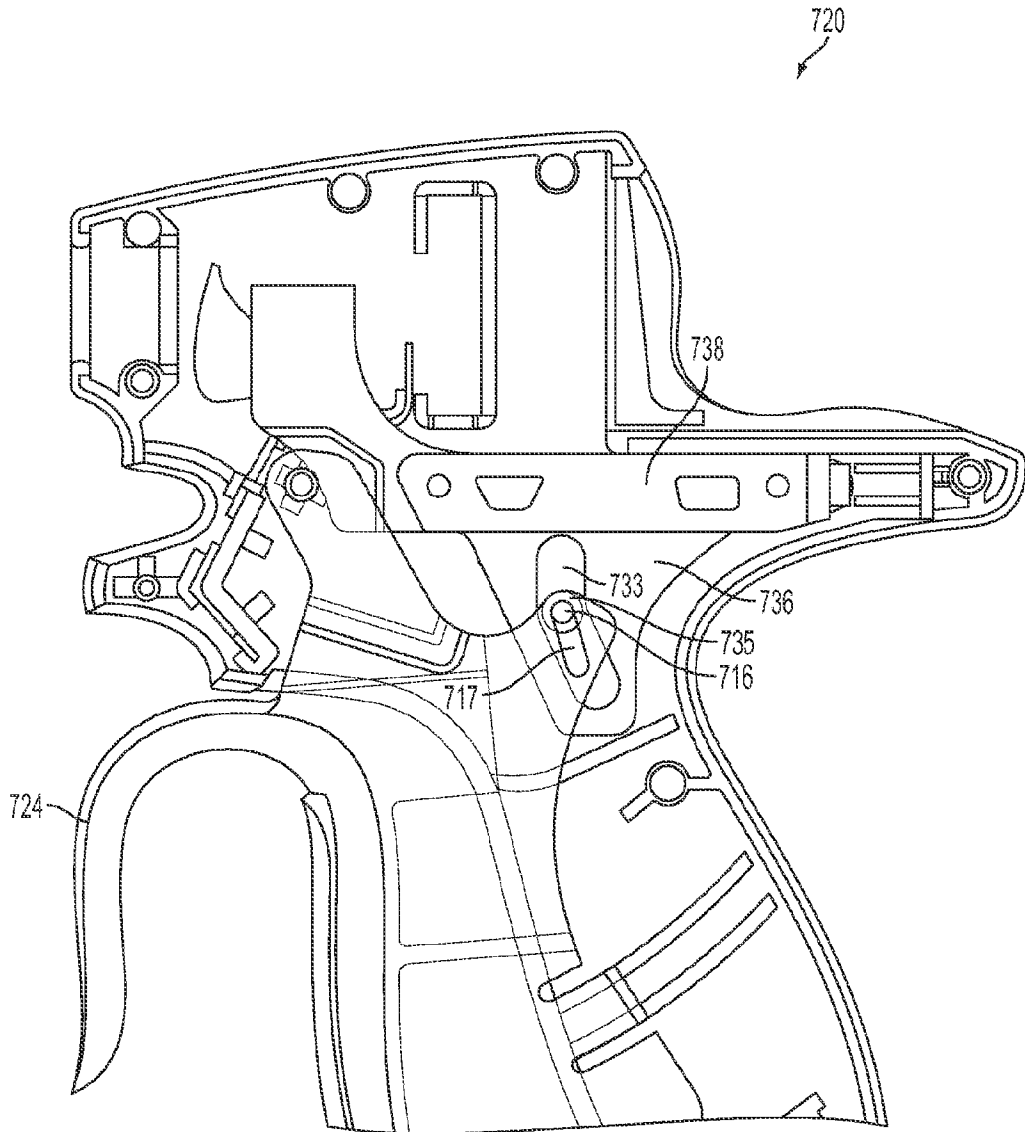

FIG. 15J

36/42

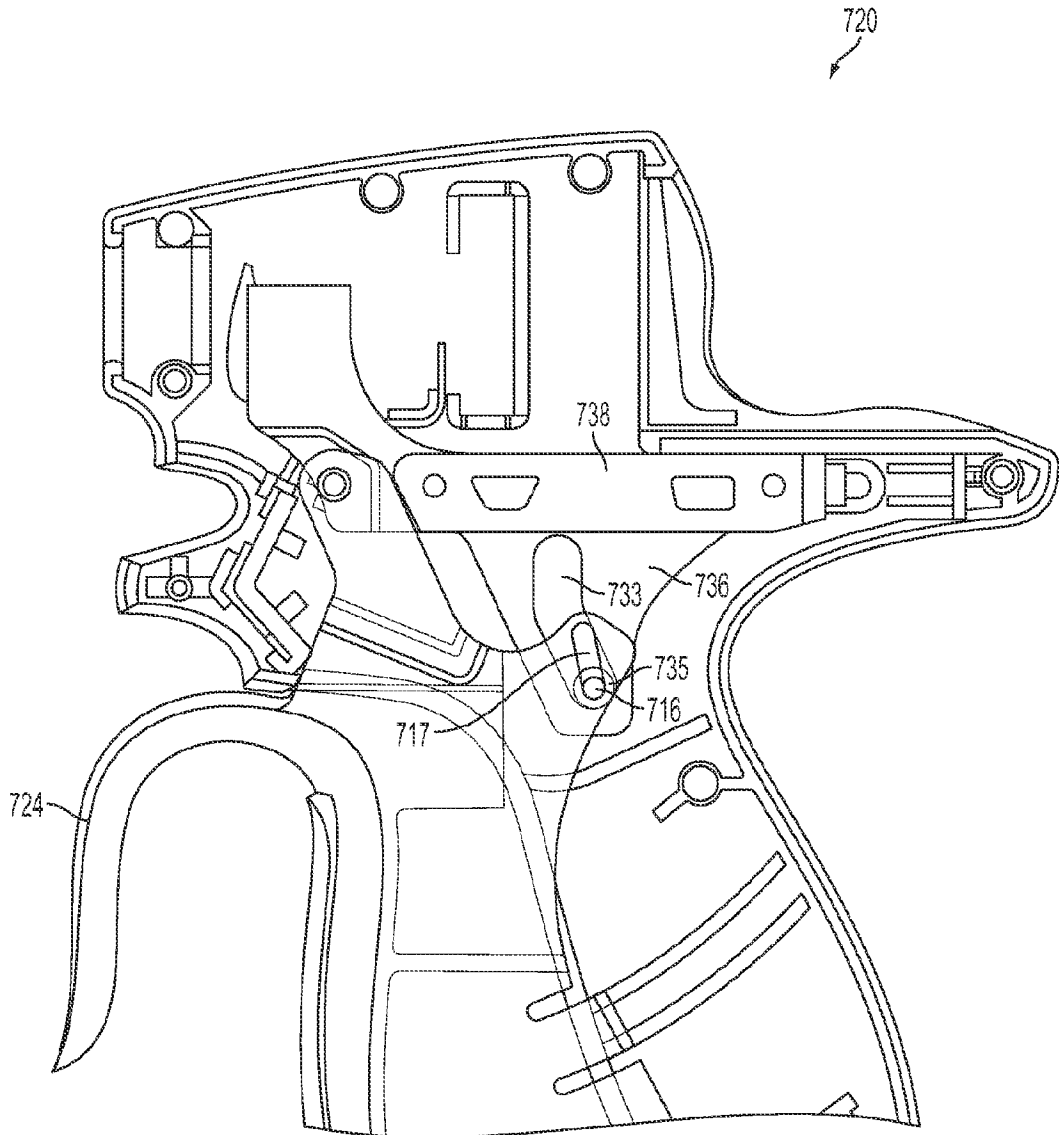

FIG. 15K

37/42

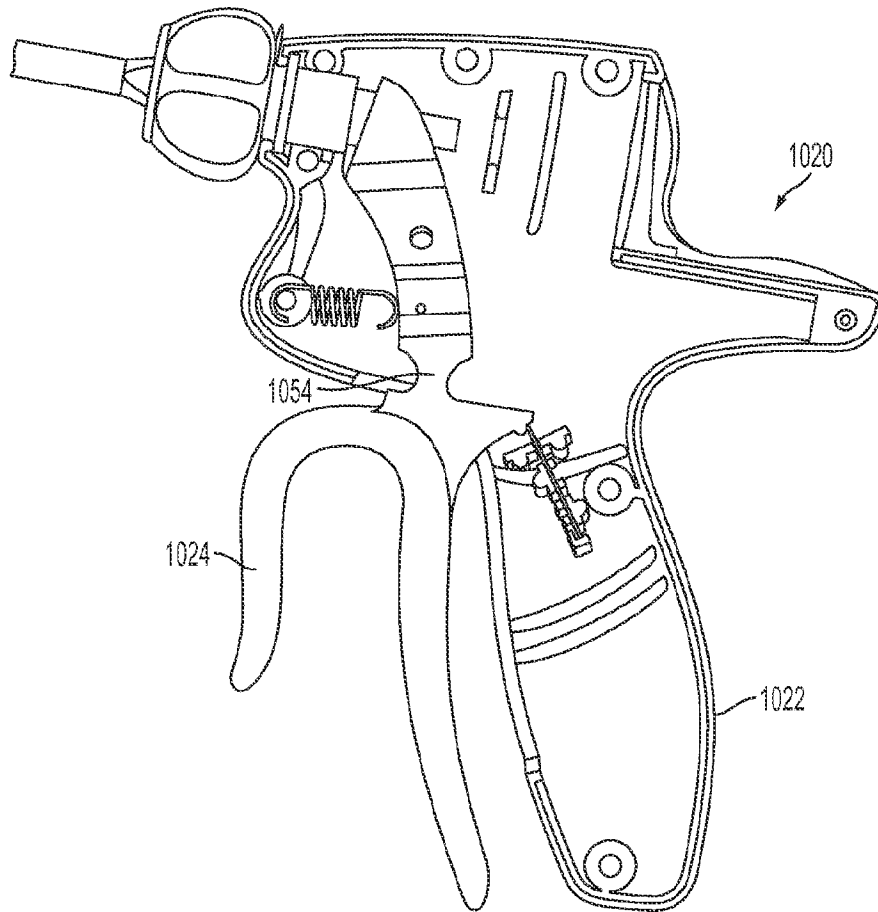

FIG. 16

OPPOSING COMPRESSION

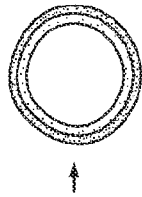

FIG. 17A

OPPOSING COMPRESSION

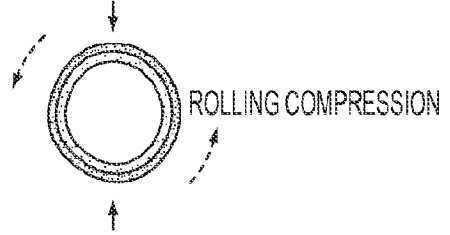

FIG. 17E

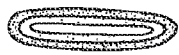

FIG. 17B



FIG. 17F

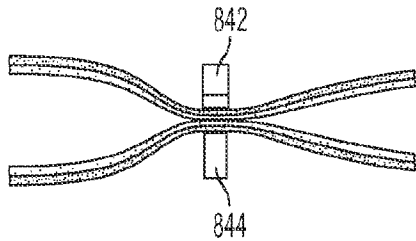

FIG. 17C

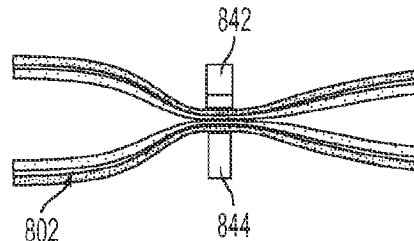

FIG. 17G

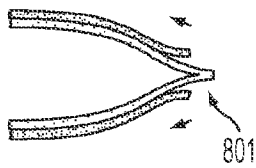

FIG. 17D

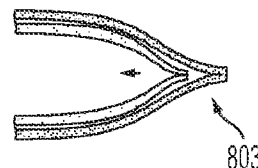

FIG. 17H

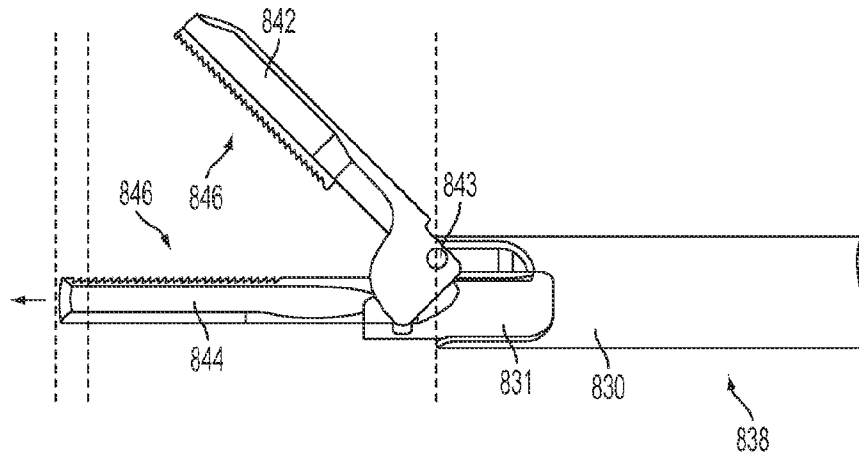

FIG. 18A

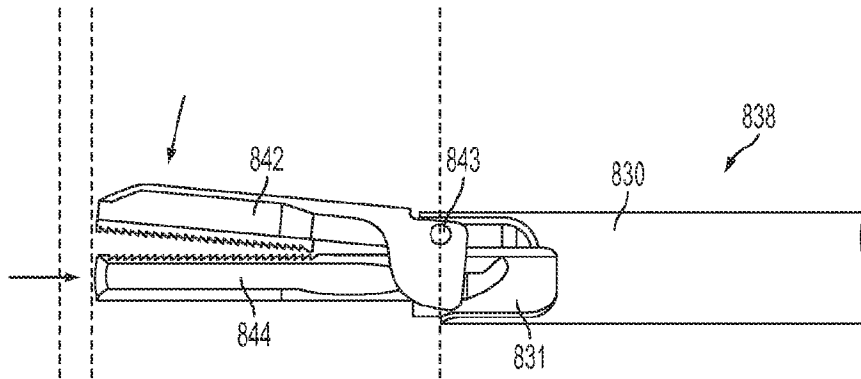

FIG. 18B

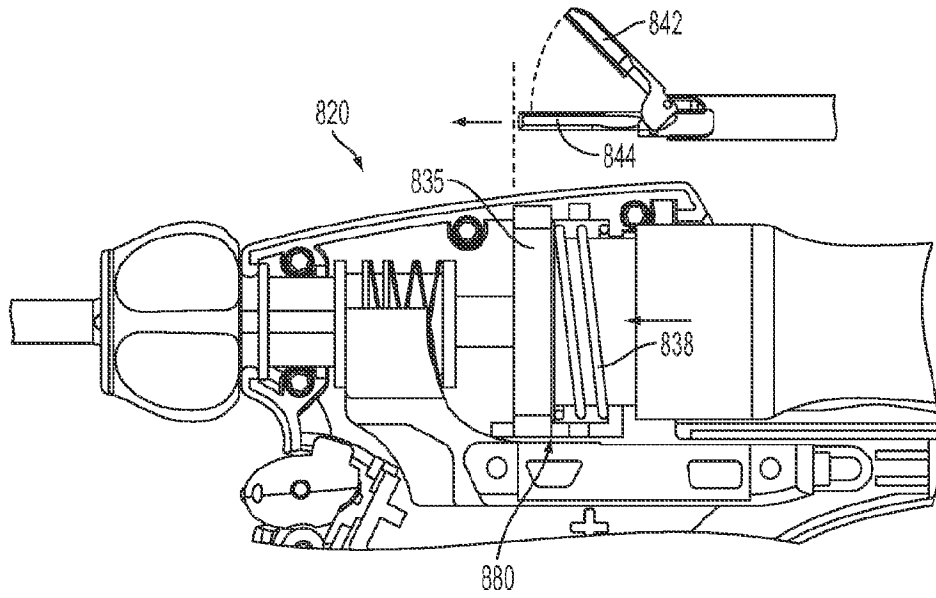

FIG. 19A

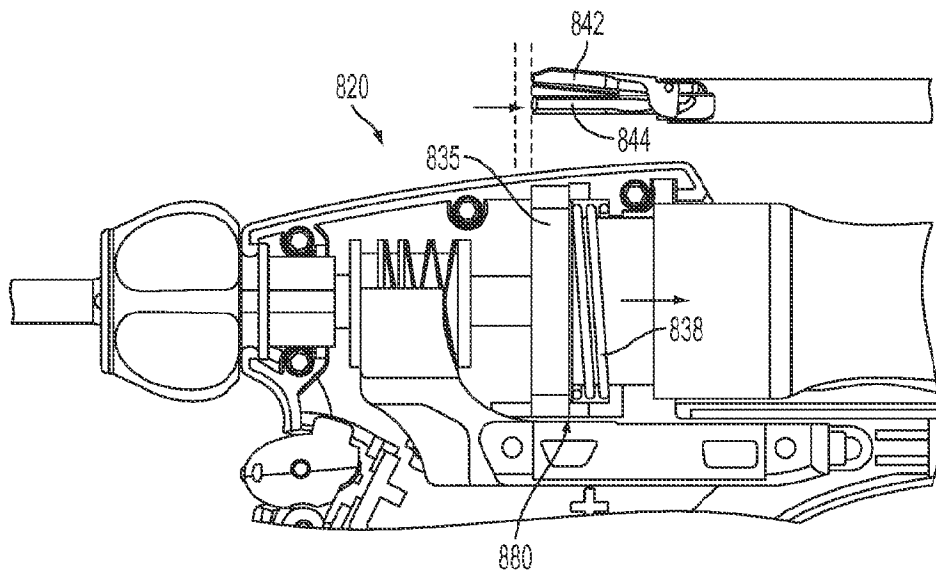

FIG. 19B

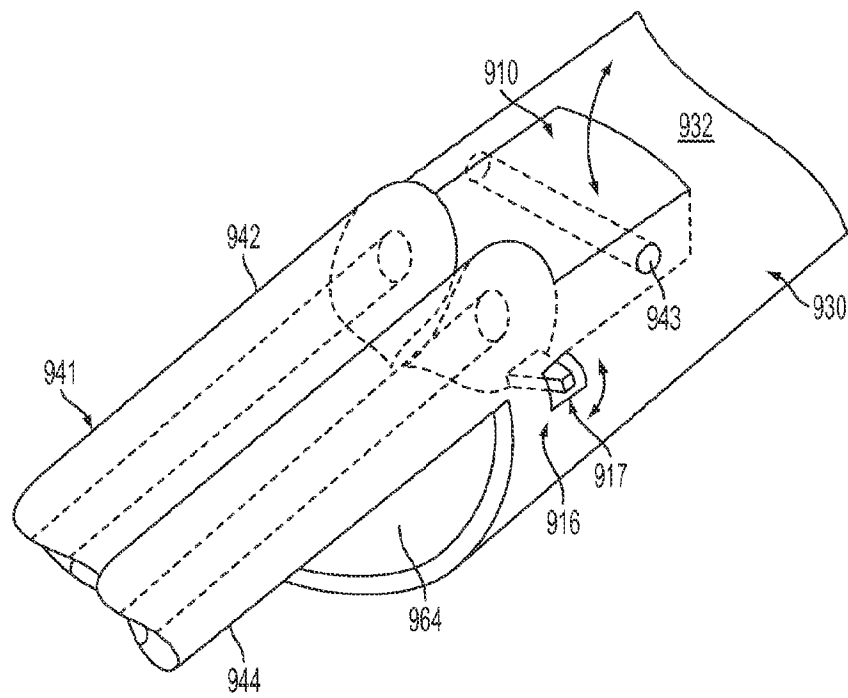

FIG. 20

42/42

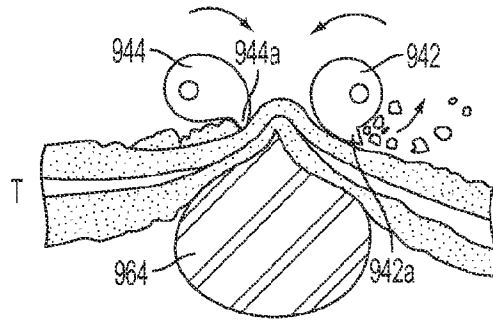

FIG. 21A

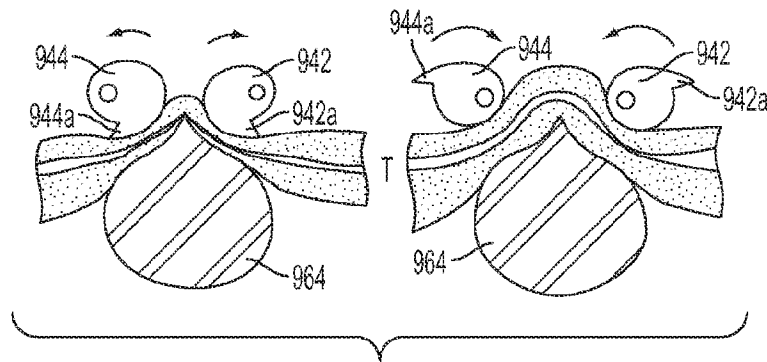

FIG. 21B

INTERNATIONAL SEARCH REPORT

International application No
PCT/US2014/022449

A. CLASSIFICATION OF SUBJECT MATTER
INV. A61B17/29 A61B17/32 A61B18/14 A61B19/00
ADD.
According to International Patent Classification (IPC) or to both national classification and IPC

B. FIELDS SEARCHED
Minimum documentation searched (classification system followed by classification symbols)
A61B

Documentation searched other than minimum documentation to the extent that such documents are included in the fields searched

Electronic data base consulted during the international search (name of data base and, where practicable, search terms used)
EPO-Internal, WPI Data

C. DOCUMENTS CONSIDERED TO BE RELEVANT

Category*	Citation of document, with indication, where appropriate, of the relevant passages	Relevant to claim No.
X	US 2012/083783 A1 (DAVISON MARK A [US] ET AL) 5 April 2012 (2012-04-05) paragraph [0109] - paragraph [0113]; figures 18-21	1-3, 12-18
X	US 5 307 976 A (OLSON TODD [US] ET AL) 3 May 1994 (1994-05-03) column 6, line 61 - column 7, line 17; figures 2-7	1
A	US 5 626 587 A (BISHOP GREGORY D [US] ET AL) 6 May 1997 (1997-05-06) column 33, line 36 - line 59; figures 7, 8	1
A	US 6 129 735 A (OKADA MITSUMASA [JP] ET AL) 10 October 2000 (2000-10-10) abstract; figures 1-17	19
	----- -/--	

Further documents are listed in the continuation of Box C.

See patent family annex.

* Special categories of cited documents :

<p>"A" document defining the general state of the art which is not considered to be of particular relevance</p> <p>"E" earlier application or patent but published on or after the international filing date</p> <p>"L" document which may throw doubts on priority claim(s) or which is cited to establish the publication date of another citation or other special reason (as specified)</p> <p>"O" document referring to an oral disclosure, use, exhibition or other means</p> <p>"P" document published prior to the international filing date but later than the priority date claimed</p>	<p>"T" later document published after the international filing date or priority date and not in conflict with the application but cited to understand the principle or theory underlying the invention</p> <p>"X" document of particular relevance; the claimed invention cannot be considered novel or cannot be considered to involve an inventive step when the document is taken alone</p> <p>"Y" document of particular relevance; the claimed invention cannot be considered to involve an inventive step when the document is combined with one or more other such documents, such combination being obvious to a person skilled in the art</p> <p>"&" document member of the same patent family</p>
---	---

Date of the actual completion of the international search 3 September 2014	Date of mailing of the international search report 11/09/2014
---	--

Name and mailing address of the ISA/ European Patent Office, P.B. 5818 Patentlaan 2 NL - 2280 HV Rijswijk Tel. (+31-70) 340-2040, Fax: (+31-70) 340-3016	Authorized officer Moers, Roelof
--	---

INTERNATIONAL SEARCH REPORT

International application No.
PCT/US2014/022449

Box No. II Observations where certain claims were found unsearchable (Continuation of item 2 of first sheet)

This international search report has not been established in respect of certain claims under Article 17(2)(a) for the following reasons:

1. Claims Nos.:
because they relate to subject matter not required to be searched by this Authority, namely:

2. Claims Nos.:
because they relate to parts of the international application that do not comply with the prescribed requirements to such an extent that no meaningful international search can be carried out, specifically:

3. Claims Nos.:
because they are dependent claims and are not drafted in accordance with the second and third sentences of Rule 6.4(a).

Box No. III Observations where unity of invention is lacking (Continuation of item 3 of first sheet)

This International Searching Authority found multiple inventions in this international application, as follows:

see additional sheet

1. As all required additional search fees were timely paid by the applicant, this international search report covers all searchable claims.

2. As all searchable claims could be searched without effort justifying an additional fees, this Authority did not invite payment of additional fees.

3. As only some of the required additional search fees were timely paid by the applicant, this international search report covers only those claims for which fees were paid, specifically claims Nos.:

4. No required additional search fees were timely paid by the applicant. Consequently, this international search report is restricted to the invention first mentioned in the claims; it is covered by claims Nos.:

Remark on Protest

- The additional search fees were accompanied by the applicant's protest and, where applicable, the payment of a protest fee.
- The additional search fees were accompanied by the applicant's protest but the applicable protest fee was not paid within the time limit specified in the invitation.
- No protest accompanied the payment of additional search fees.

FURTHER INFORMATION CONTINUED FROM PCT/ISA/ 210

This International Searching Authority found multiple (groups of) inventions in this international application, as follows:

1. claims: 1-18

Surgical instrument having a trigger moveable through first and second actuated positions.

2. claims: 19-25

Surgical instrument having an ultrasonic waveguide and a clamp arm with two camming members.

INTERNATIONAL SEARCH REPORT

International application No
PCT/US2014/022449

C(Continuation). DOCUMENTS CONSIDERED TO BE RELEVANT		
Category*	Citation of document, with indication, where appropriate, of the relevant passages	Relevant to claim No.
A	US 2012/109159 A1 (JORDAN GARY [US] ET AL) 3 May 2012 (2012-05-03) abstract; figures 1, 2 -----	19
A	US 8 382 775 B1 (BENDER THEODORE M [US] ET AL) 26 February 2013 (2013-02-26) column 31, line 36 - line 60; figures 8a-j -----	19
A	US 2012/253370 A1 (ROSS ANTHONY B [US] ET AL) 4 October 2012 (2012-10-04) abstract; figures 1-4 -----	19

INTERNATIONAL SEARCH REPORT

Information on patent family members

International application No PCT/US2014/022449

Patent document cited in search report	Publication date	Patent family member(s)	Publication date
US 2012083783	A1	05-04-2012	NONE

US 5307976	A	03-05-1994	US 5307976 A 03-05-1994
			US 5332142 A 26-07-1994

US 5626587	A	06-05-1997	AT 225143 T 15-10-2002
			AU 2161795 A 21-12-1995
			DE 69528416 D1 07-11-2002
			DE 69528416 T2 11-03-2004
			DK 0686374 T3 28-10-2002
			EP 0686374 A2 13-12-1995
			ES 2183854 T3 01-04-2003
			JP 3709223 B2 26-10-2005
			JP H0847498 A 20-02-1996
			PT 686374 E 28-02-2003
			US 5626587 A 06-05-1997

US 6129735	A	10-10-2000	NONE

US 2012109159	A1	03-05-2012	NONE

US 8382775	B1	26-02-2013	US 8382775 B1 26-02-2013
			US 2013178698 A1 11-07-2013

US 2012253370	A1	04-10-2012	NONE
