



US00D705908S

(12) **United States Design Patent**
Koyama et al.

(10) **Patent No.:** **US D705,908 S**

(45) **Date of Patent:** **** May 27, 2014**

(54) **AIRPLANE LAVATORY**

D593,647 S * 6/2009 Bock et al. D23/271

* cited by examiner

(71) Applicant: **The Yokohama Rubber Co., Ltd.**
Tokyo (JP)

Primary Examiner — Robert Delehanty
(74) *Attorney, Agent, or Firm* — Banner & Witcoff, Ltd.

(72) Inventors: **Takashi Koyama**, Hiratsuka (JP);
Masayuki Fushimi, Koto-ku (JP)

(57) **CLAIM**

The ornamental design for an airplane lavatory, as shown and described.

(73) Assignee: **The Yokohama Rubber Co., Ltd.**,
Tokyo (JP)

DESCRIPTION

(**) Term: **14 Years**

FIG. 1 is a front, right perspective view of an airplane lavatory showing our new design;

(21) Appl. No.: **29/468,346**

FIG. 2 is a front view thereof;

(22) Filed: **Sep. 30, 2013**

FIG. 3 is a rear view thereof;

(30) **Foreign Application Priority Data**

Apr. 2, 2013 (JP) 2013-007430

FIG. 4 is a left side view thereof;

(51) **LOC (10) CL.** **23-02**

FIG. 5 is a right side view thereof;

(52) **U.S. CL.**

USPC **D23/274**; D23/308

FIG. 6 is a top plan view thereof;

(58) **Field of Classification Search**

USPC D23/270–271, 274, 286, 303, 308;

D6/641–642, 648, 698; D12/345, 40,

D12/43; 244/119–120, 117 R

See application file for complete search history.

FIG. 7 is a bottom view thereof;

FIG. 8 is a sectional view taken along lines 8-8 shown in FIG. 2;

FIG. 9 is a sectional view taken along lines 9-9 shown in FIG. 4;

FIG. 10 is a sectional view taken along lines 10-10 shown in FIG. 4;

FIG. 11 is a sectional view taken along lines 11-11 shown in FIG. 6;

FIG. 12 is a front, left perspective view showing an interior part thereof;

FIG. 13 is a rear, left perspective view showing the interior part thereof; and,

FIG. 14 is a sectional view taken along lines 11-11 shown in FIG. 6 in a state where a folding shelf is unfolded.

The broken lines shown are included for the purpose of illustrating the unclaimed portions of the airplane lavatory and form no part of the claimed design.

(56) **References Cited**

U.S. PATENT DOCUMENTS

D156,864	S	*	1/1950	Brown et al.	D23/284
5,150,863	A	*	9/1992	Hozumi	D12/345
D487,137	S	*	2/2004	Itakura	D23/274
D592,735	S	*	5/2009	Scoley et al.	D23/274

1 Claim, 14 Drawing Sheets

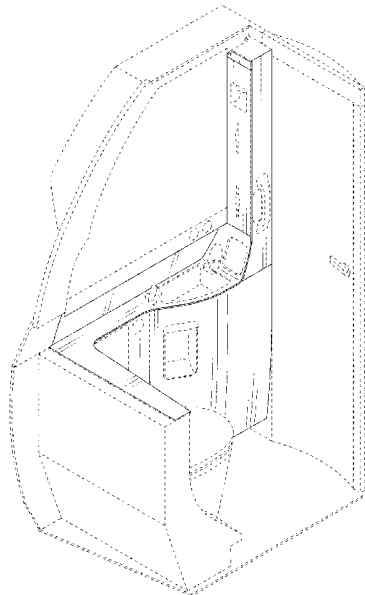

Fig. 1

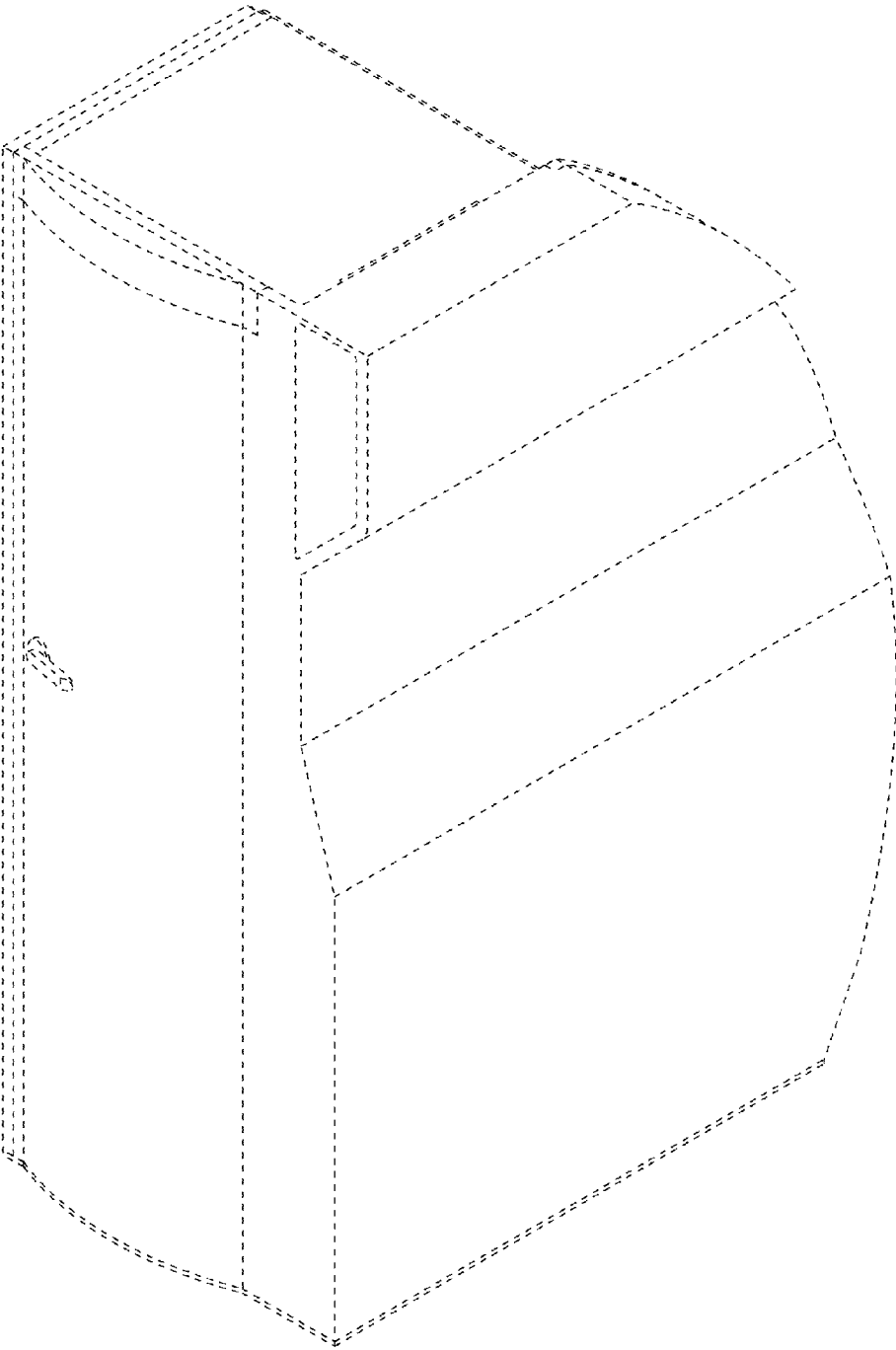

Fig. 2

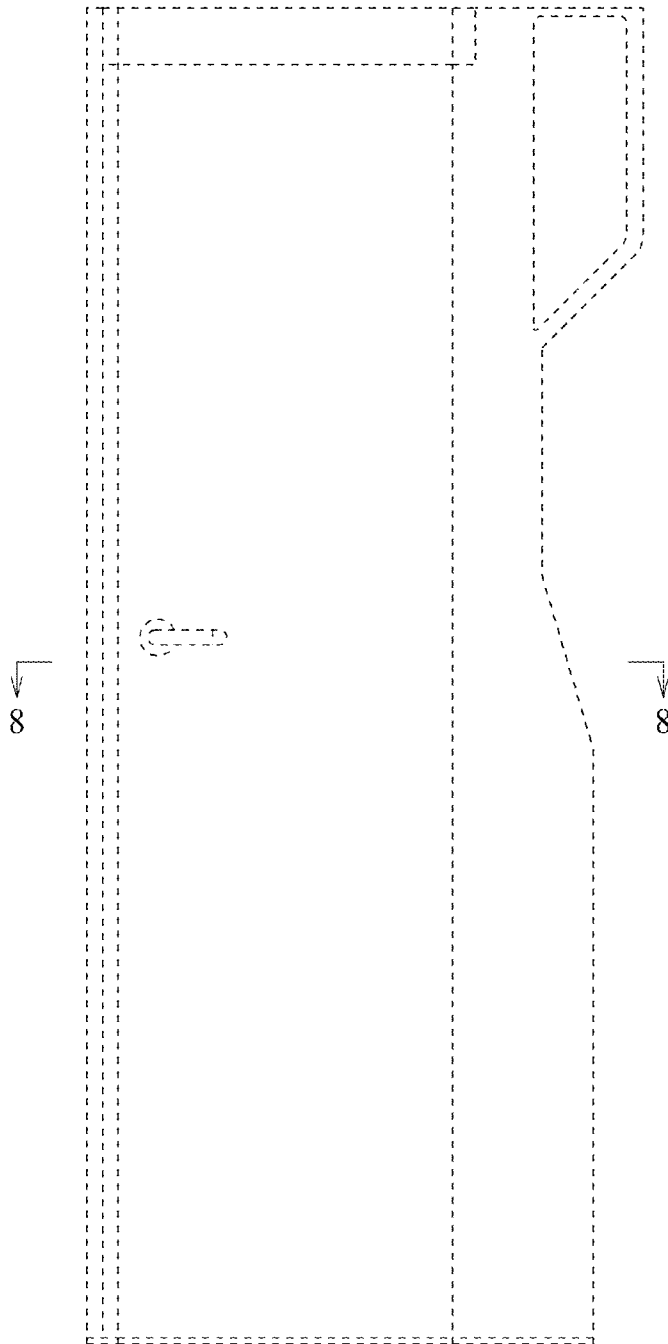

Fig. 3

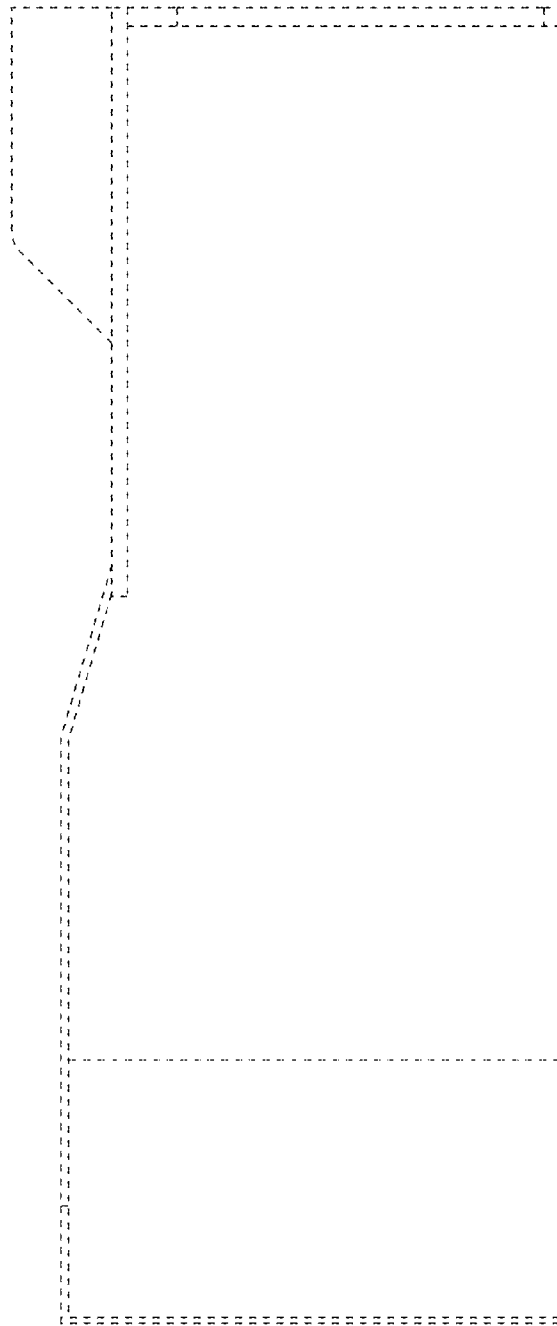

Fig. 4

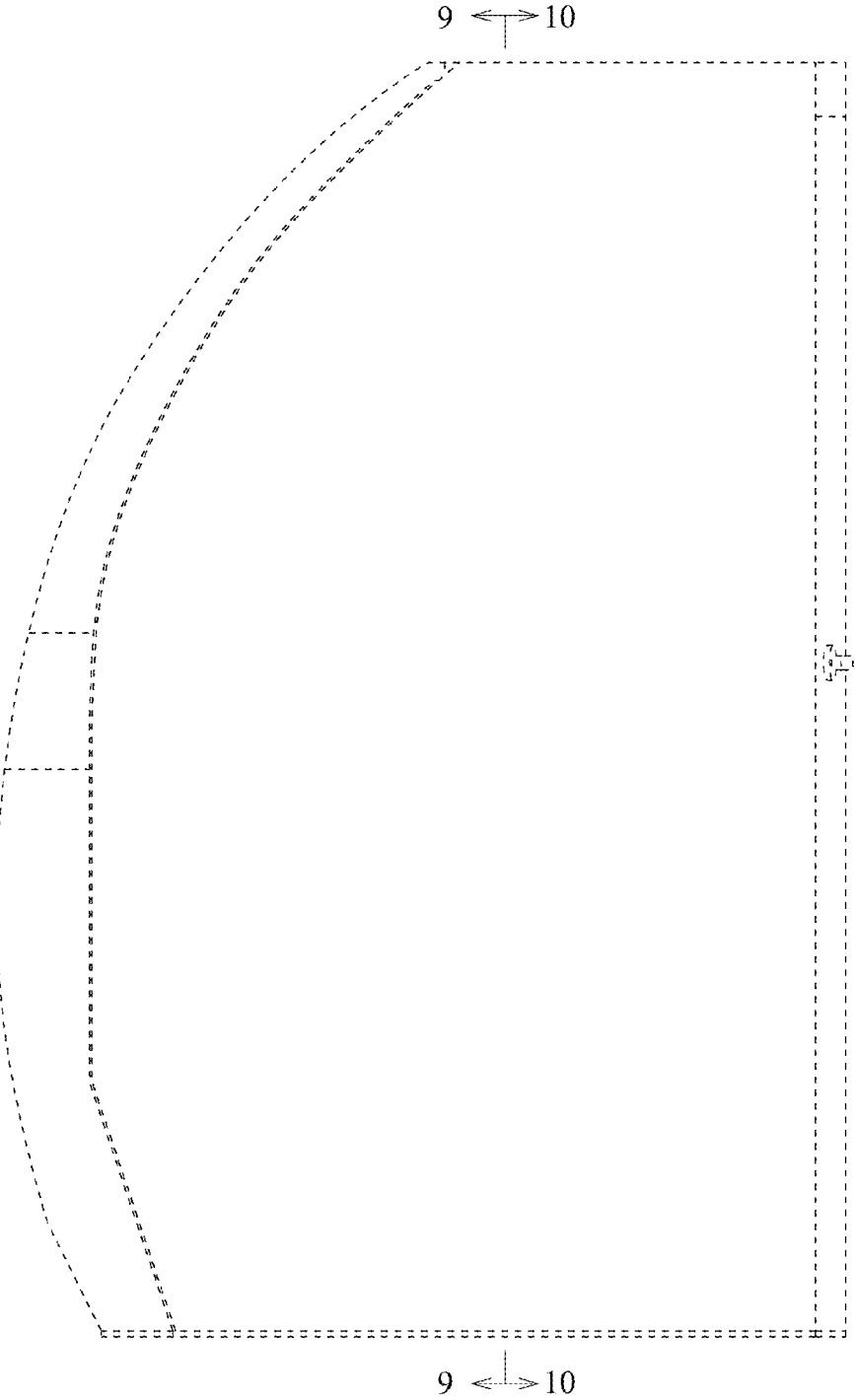

Fig. 5

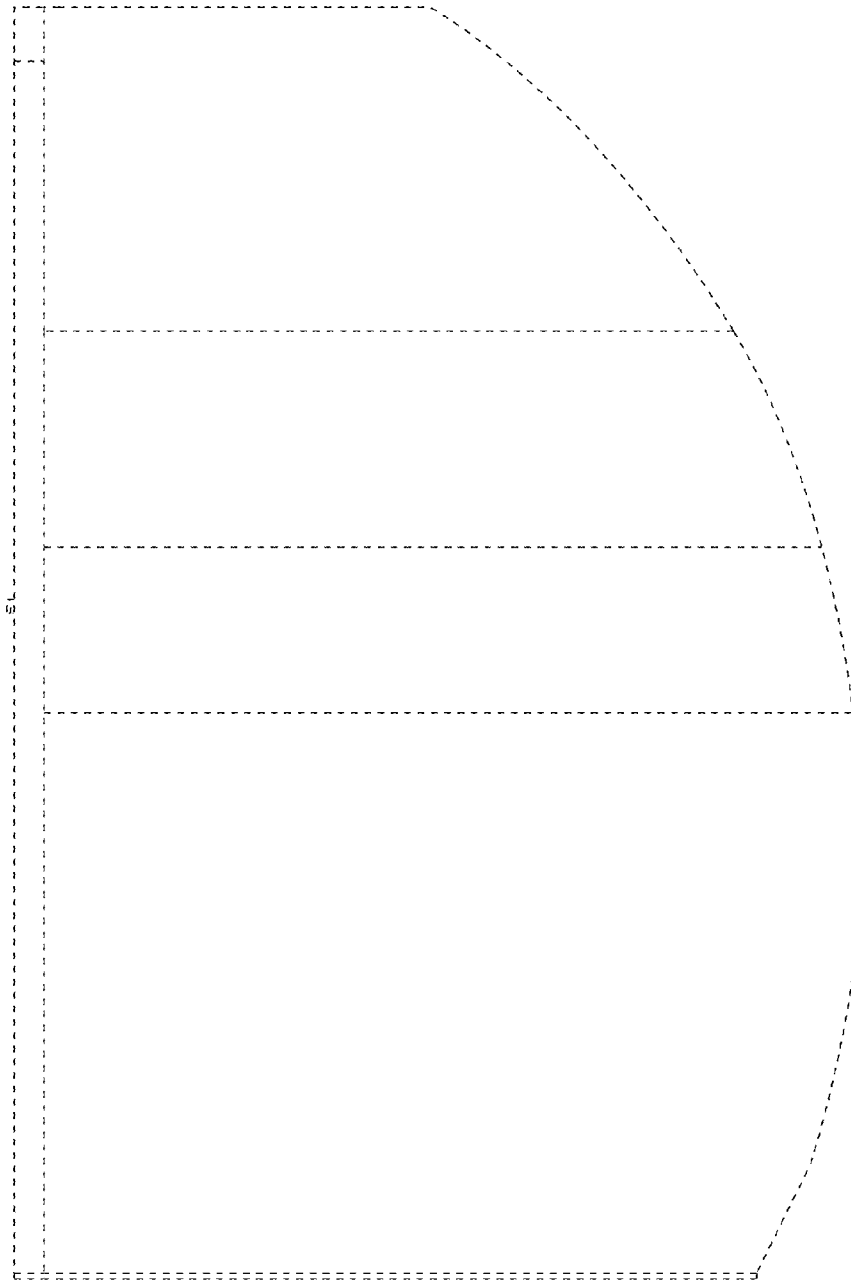

Fig. 6

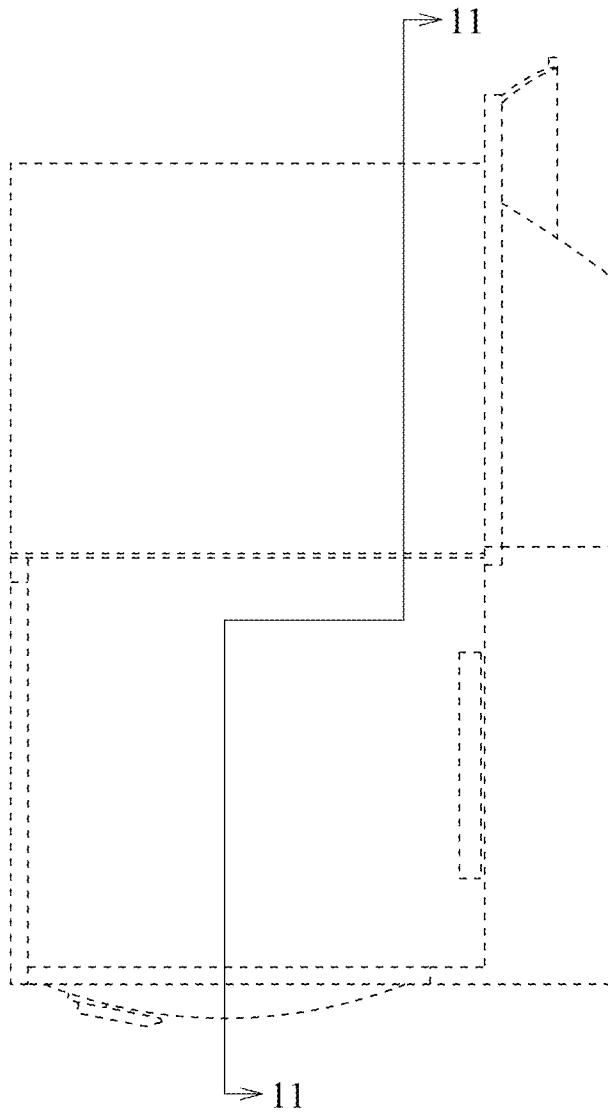

Fig. 7

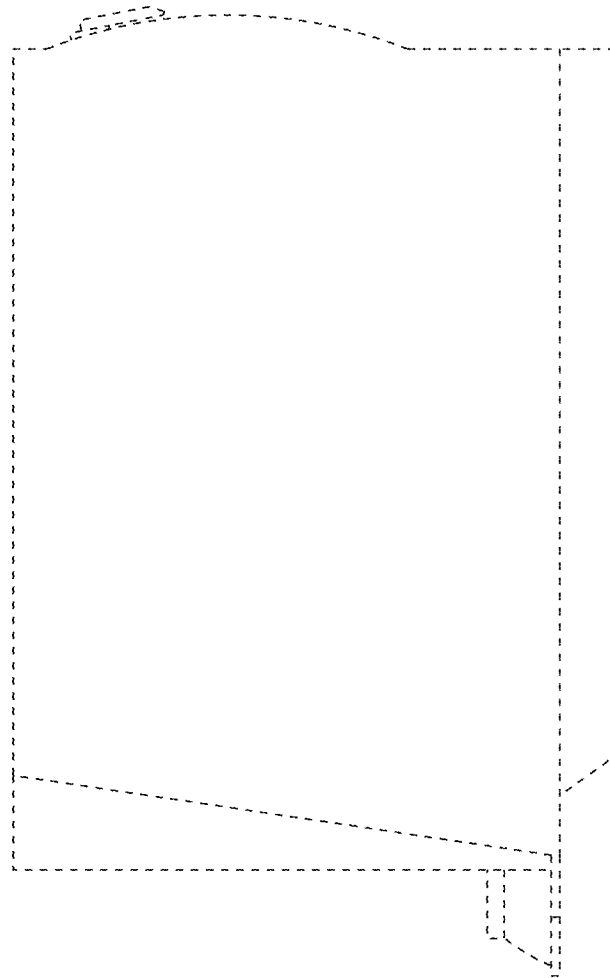

Fig. 8

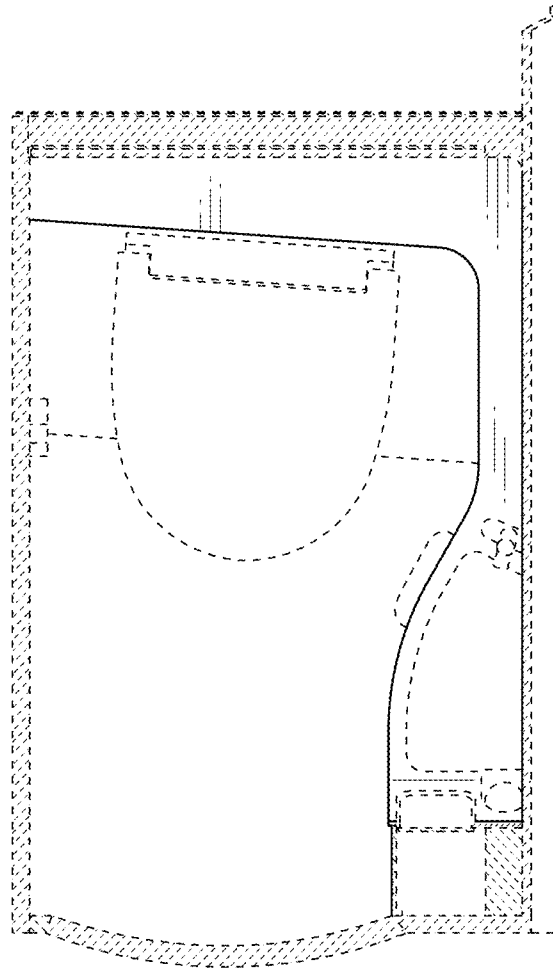

Fig. 9

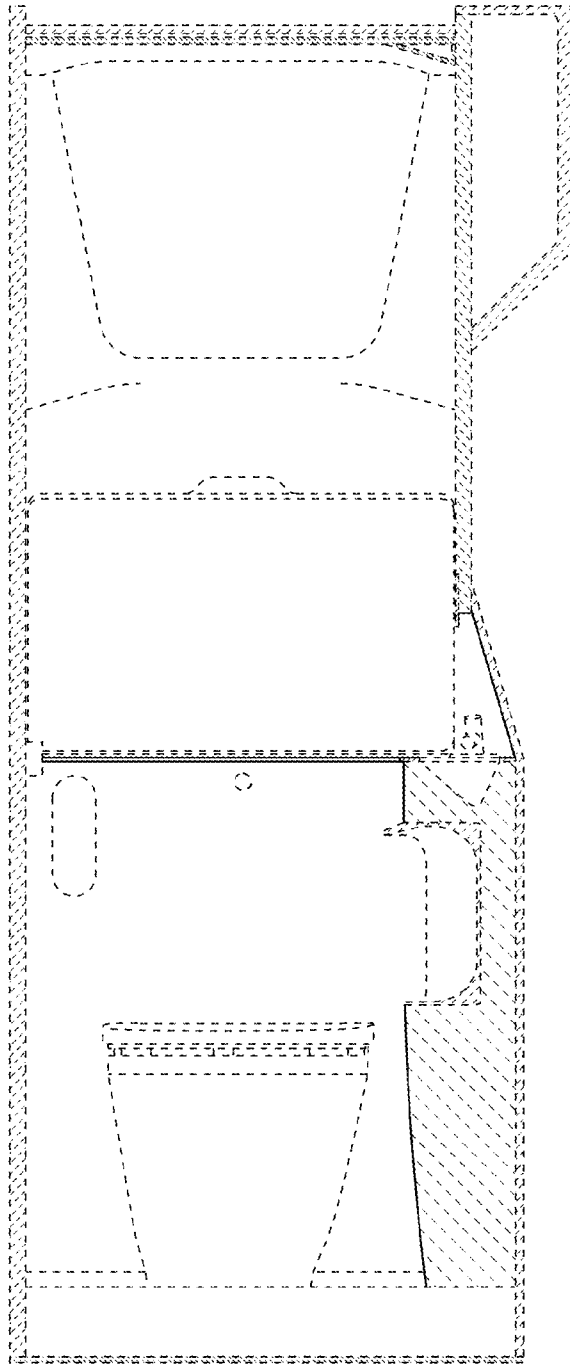

Fig. 10

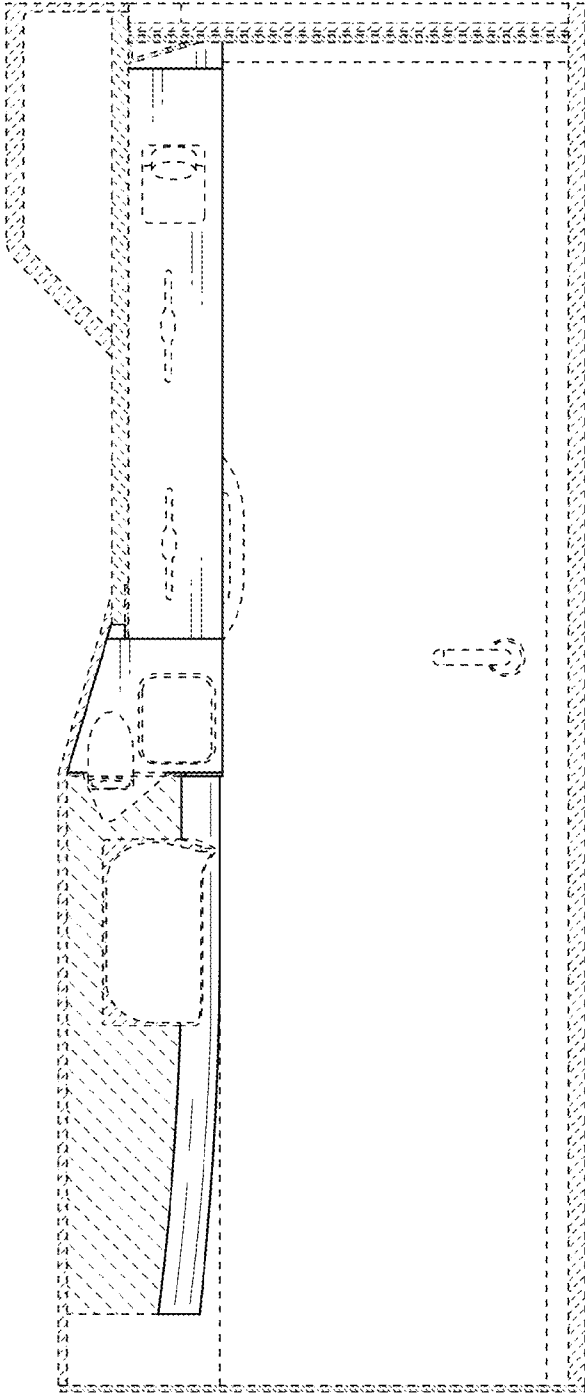

Fig. 11

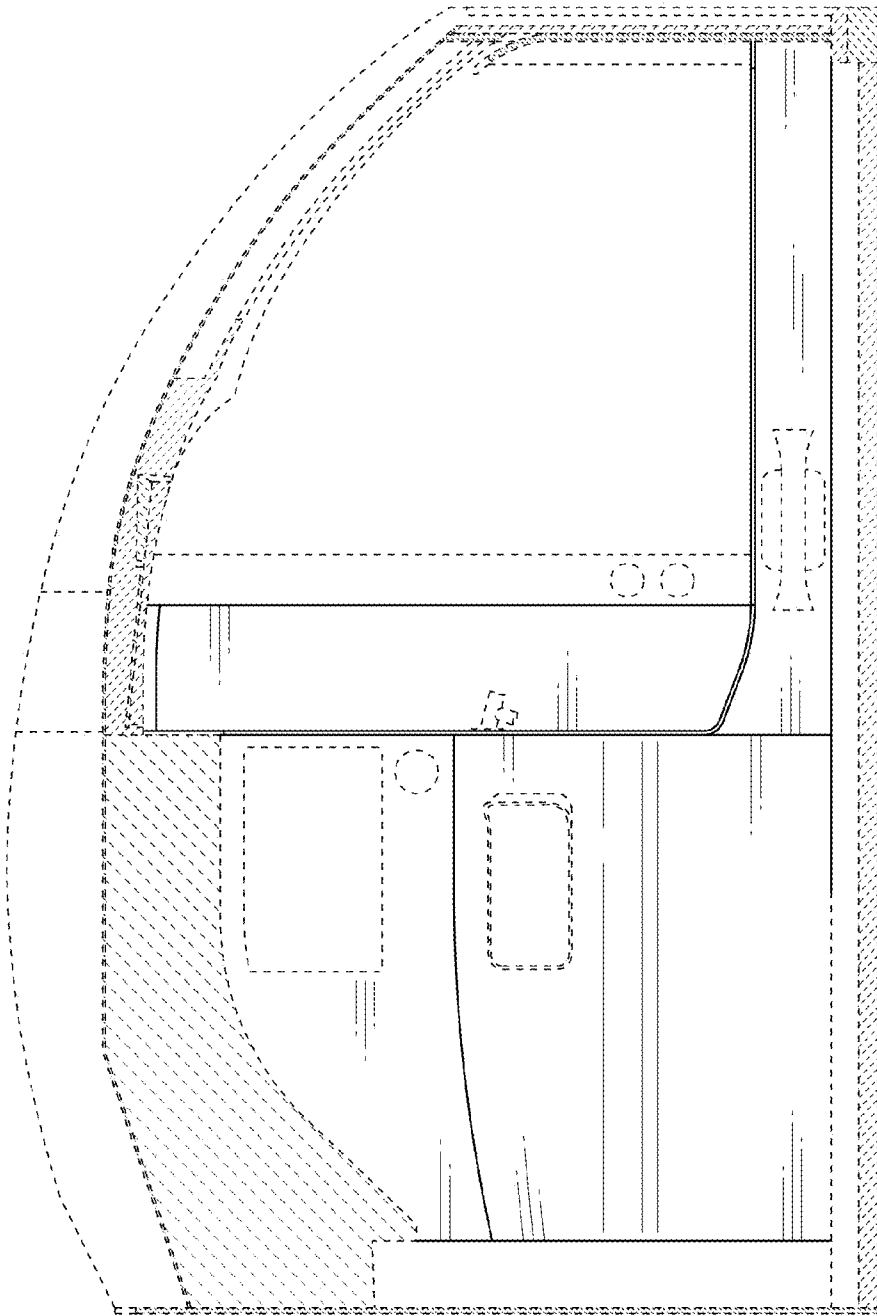

Fig. 12

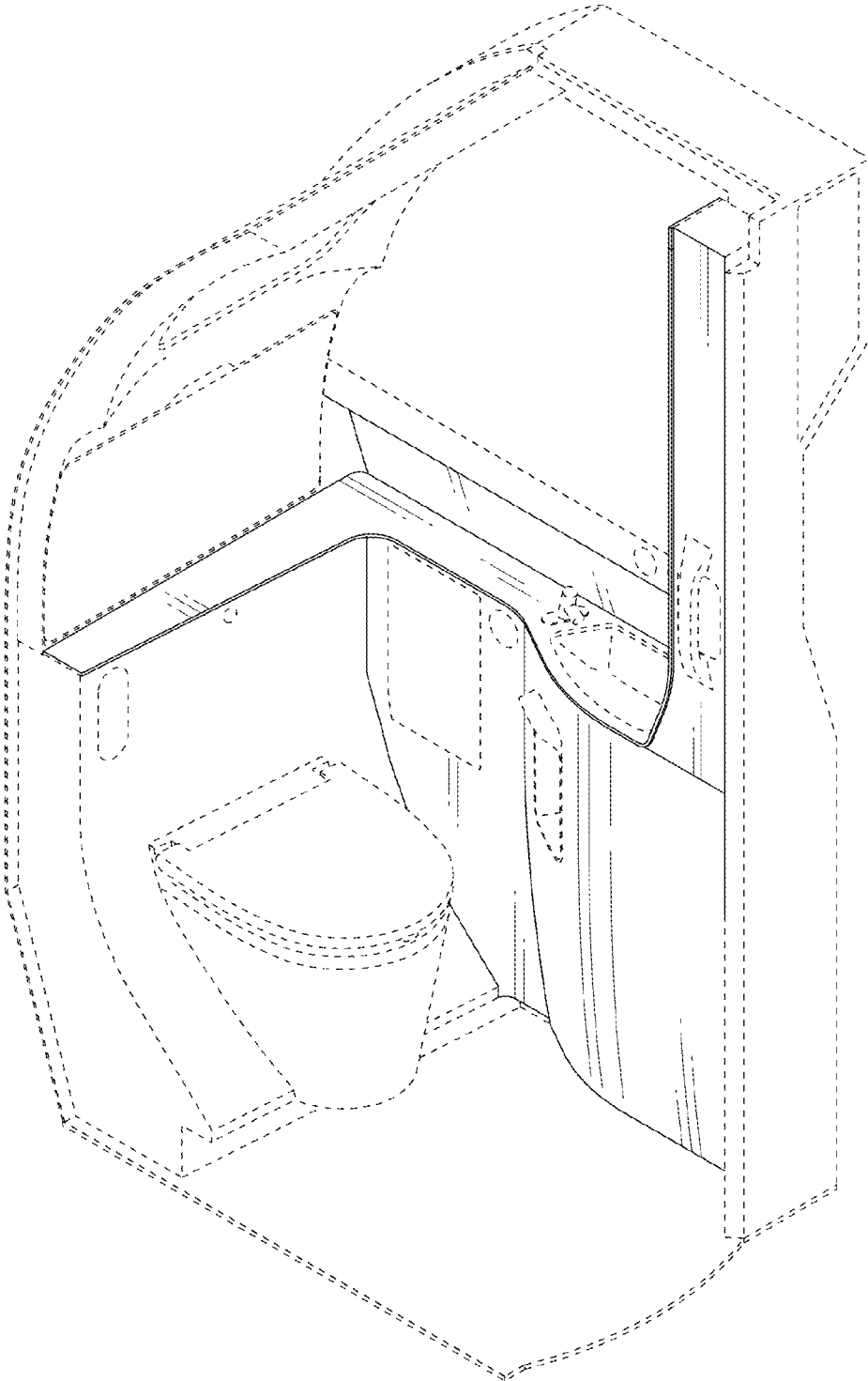

Fig. 13

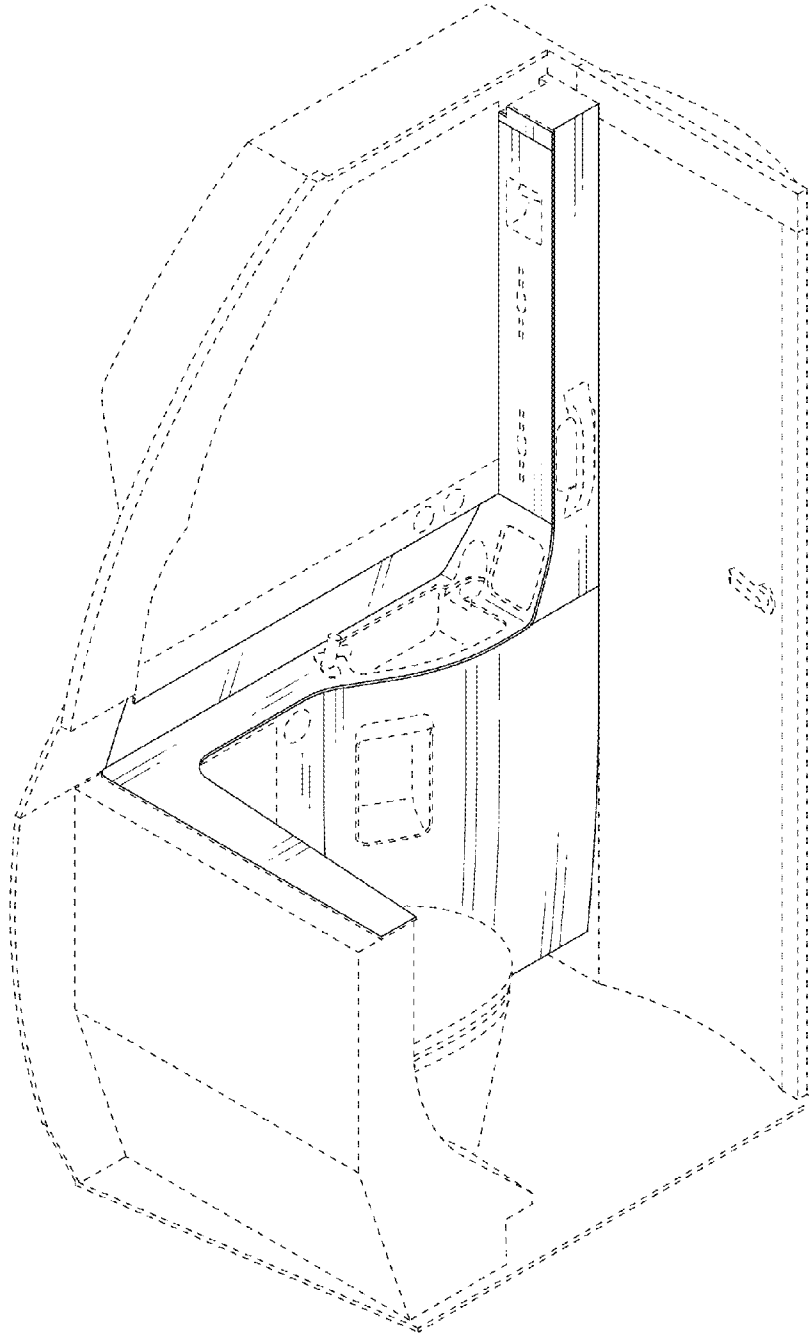

Fig. 14

