

N. C. HINSDALE.  
 AIR MATTRESS, SEAT, AND THE LIKE.  
 APPLICATION FILED SEPT. 16, 1909.

961,231.

Patented June 14, 1910.

**Fig - 1 -**

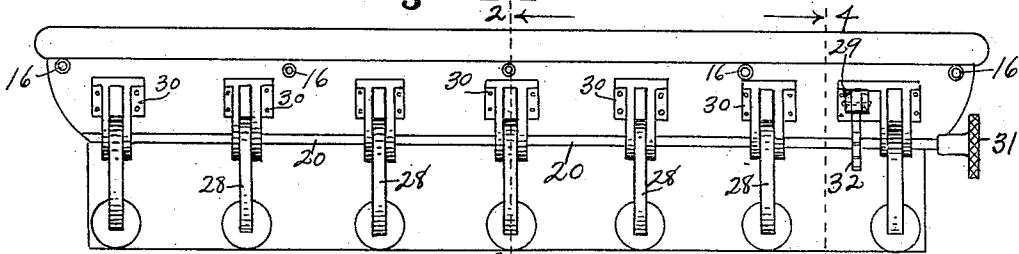

**Fig - 2 -**

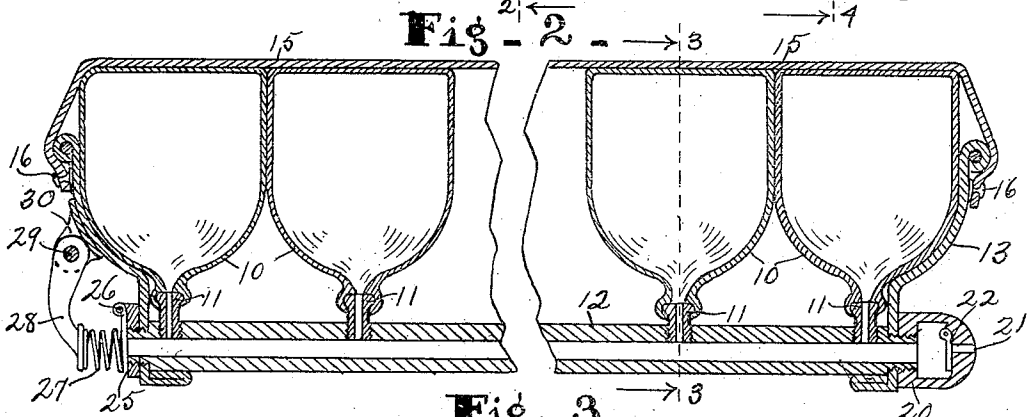

**Fig - 3 -**

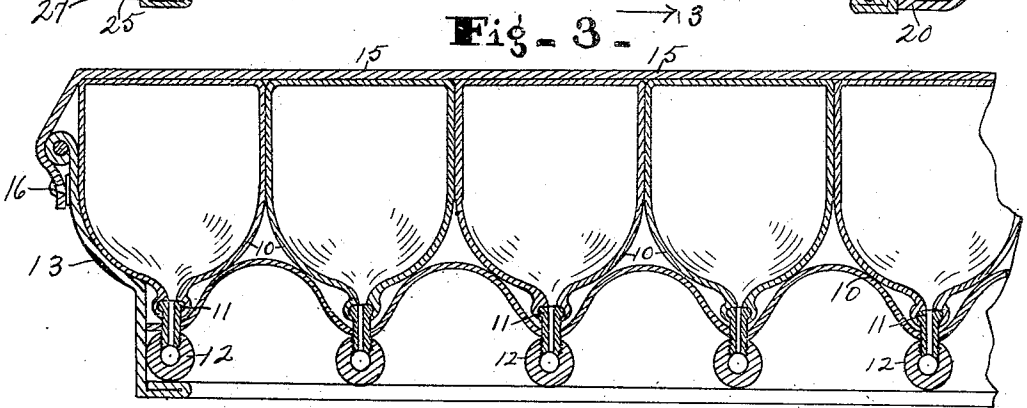

**Fig - 4 -**

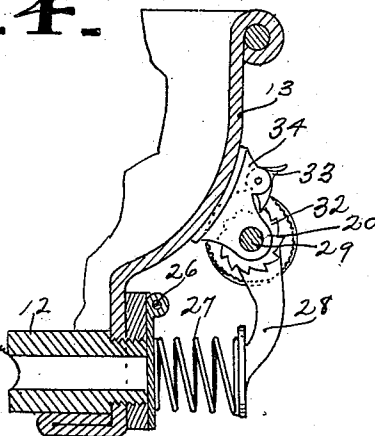

WITNESSES:

L. J. Bork  
 O. M. McLaughlin

INVENTOR,  
**Nehemiah C. Hinsdale.**

BY

*J. A. Lockwood*  
 ATTORNEY.

# UNITED STATES PATENT OFFICE.

NEHEMIAH C. HINSDALE, OF MARION, INDIANA, ASSIGNOR TO HINSDALE PNEUMATIC CUSHION AND MATTRESS COMPANY, OF MARION, INDIANA, A CORPORATION OF INDIANA.

AIR MATTRESS, SEAT, AND THE LIKE.

961,231.

Specification of Letters Patent. Patented June 14, 1910.

Application filed September 16, 1909. Serial No. 517,994.

*To all whom it may concern:*

Be it known that I, NEHEMIAH C. HINSDALE, of Marion, county of Grant, and State of Indiana, have invented a certain new and useful Air Mattress, Seat, and the Like; and I do hereby declare that the following is a full, clear, and exact description thereof, reference being had to the accompanying drawings, in which like numerals refer to like parts.

The object of this invention is to improve air mattresses, seats or the like of the type as set forth in my former application filed Dec. 12, 1908, Serial No. 467,308.

The chief feature of this invention consists in providing each tube, by which the cushions are mounted, with an air inlet valve and a spring-controlled air outlet valve, so that there will be no communication between the series of cushions on the different tubes and there will be more direct effect from the air inlet valve than from the expansion or action of any of the cushions. They will quickly fill.

Another feature of the invention consists in providing an improved support for the cushions, whereby the shoulders or sides of the cushions at their lower ends will be supported or reinforced. A corrugated metal plate is located upon the series of air tubes with upwardly extending elevated portions between each pair of tubes adapted to support the sides of the cushions at the lower end when a person lies upon the mattress.

The invention applies not only to mattresses but to car seats, automobile seats and the like.

These and other features of the invention will be understood from the accompanying drawings and the following description and claims:

In the drawings Figure 1 is an elevation of one end of the air mattress. Fig. 2 is a longitudinal section on the line 2—2 of Fig. 1, said section being centrally broken away so as to show four cushions and the portions of one air tube on which they are mounted. Fig. 3 is a transverse section on the line 3—3 of Fig. 2 with one end broken away. Fig. 4 is a section on the line 4—4 of Fig. 1.

In the drawings there is shown a number of rubber cushions 10 flat on the top and shaped at their lower ends somewhat like an inverted jug, so that it has sides or shoulders at the bottom and a mouth secured on a

metal nipple 11 which screws in the tube 12. There is a large number of these cushions, several being placed upon each tube 12 and there being several parallel tubes in one mattress. The cushions abut against each other and are surrounded on all four sides by a frame 13 made of metal that is secured to and carries the pipes 12. The sides of this frame are curved to conform with the sides of the lower parts of the cushions, so that the cushions on the outside of the series will rest against and be reinforced by said frame 13. When the cushions are in place they are covered over by a cover 15 that is fastened at its edges to buttons 16 on said frame 13.

The cushions are in constant communication with the tube with which they are connected, but the tubes 12 are not in communication with each other. On the end of each tube 12, as seen in Fig. 2, a valve chamber 20 is screwed that has an inlet port 21 closed by a check valve 22. It admits air when a cushion is expanding, but does not permit any air to escape. There is one of these air inlet valve-closed ports at the end of each tube 12. At the other end of each tube 12 there is a safety valve 25 hinged at 26 and held closed by a spring 27 on the end of the arm 28 that is fastened rigidly on a rock shaft 29 fulcrumed in ears 30 secured to the frame 13. The rock shaft is turned by the nut 31 for tightening the springs 27 and is held in its adjusted position by the ratchet 32 secured on said shaft and engaged by the pawl 33 pivoted in the ear 34 secured to the frame 13. In this way the tension of the springs 27 can be adjusted so as to afford the desired relief or escape of air when the cushions are subjected to the desired maximum strain. The valve 25 will yield before the pressure in the cushion has become great enough to explode or burst the cushion, and therefore, the valve 25 is a cushion protecting valve. In this construction the cushions 10 are made of rubber strong enough to naturally and automatically expand and assume normal dimensions, that is, in the way the air is drawn into the tubes 12 and then into the cushions.

What I claim as my invention and desire to secure by Letters Patent is:

1. An air mattress seat or the like including a frame, a plurality of parallel tubes therein independent of each other, cushions

2  
 5 mounted on and in communication with said tubes, a valve closed air inlet port for each tube, a relief valve for closing each tube, a rock shaft mounted on the frame, arms secured thereto for each relief valve, a spring held by said arm against the relief valve, a ratchet on said rock shaft, and a pawl mounted in connection with the frame for engaging said ratchet, whereby the tension of the springs may be maintained.

10 2. An air mattress seat or the like including a plurality of air tubes, valves for closing said tubes to prevent the escape of air normally, cushions mounted upon and in communication with said tubes, and stationary means for engaging the sides of the lower parts of the cushions for reinforcing and supporting the same.

15 3. An air mattress seat or the like including a plurality of air tubes, valves for closing said tubes to prevent the escape of air normally, cushions mounted upon and in communication with said tubes, and a plate resting upon said tubes with upwardly

25 curved portions between the rows of cushions for engaging and reinforcing the lower parts of the cushions.

30 4. An air mattress seat or the like including a plurality of cushions with tapered lowered ends, valve closed tubes upon which they are mounted, a frame surrounding the series of cushions and in which said tubes are mounted, said frame conforming to the sides of the cushions adjacent to it for reinforcing the same, a cover extending over the cushions and secured to said frame, and a plate mounted upon the tubes with upward extensions between the rows of cushions for engaging and reinforcing the lower portions thereof.

35 40 In witness whereof I have hereunto affixed my signature in the presence of the witnesses herein named.

NEHEMIAH C. HINSDALE.

Witnesses:

HARRY E. ROBERTS,  
 HERBERT M. ELLIOTT.