

(19) World Intellectual Property  
Organization  
International Bureau



(43) International Publication Date  
18 November 2004 (18.11.2004)

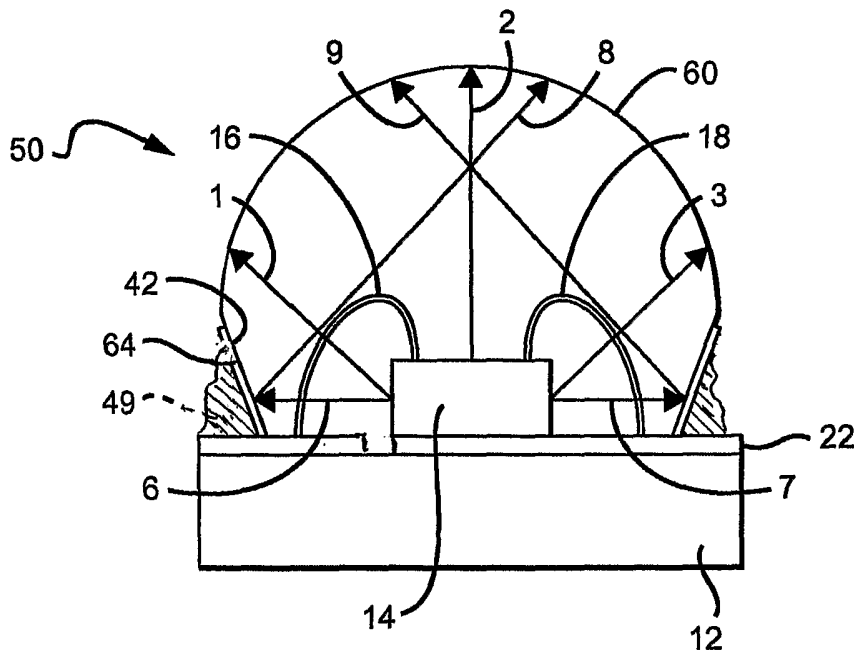
PCT

(10) International Publication Number  
**WO 2004/100279 A2**

- (51) International Patent Classification<sup>7</sup>: **H01L 33/00**
- (21) International Application Number:  
PCT/US2004/013256
- (22) International Filing Date: 28 April 2004 (28.04.2004)
- (25) Filing Language: English
- (26) Publication Language: English
- (30) Priority Data:  
60/467,193 30 April 2003 (30.04.2003) US
- (71) Applicant (for all designated States except US): **CREE, INC.** [US/US]; 4600 Silicon Drive, Durham, NC 46603 (US).
- (72) Inventors: **IBBETSON, James**; 910 Randolph Road, Santa Barbara, CA 93111 (US). **KELLER, Bernd**; 1335 San Antonio Creek Road, Santa Barbara, CA 93111 (US). **BHARANTHAN, Jayesh**; 1011 Berwick Valley Lane, Cary, NC 27513 (US).
- (74) Agent: **HEYBL, Jaye, G.**; Koppel, Jacobs, Patrick & Heybl, 555 St. Charles Drive, # 107, Thousand Oaks, CA 91360 (US).
- (81) Designated States (unless otherwise indicated, for every kind of national protection available): AE, AG, AL, AM, AT, AU, AZ, BA, BB, BG, BR, BW, BY, BZ, CA, CH, CN, CO, CR, CU, CZ, DE, DK, DM, DZ, EC, EE, EG, ES, FI, GB, GD, GE, GH, GM, HR, HU, ID, IL, IN, IS, JP, KE, KG, KP, KR, KZ, LC, LK, LR, LS, LT, LU, LV, MA, MD, MG, MK, MN, MW, MX, MZ, NA, NI, NO, NZ, OM, PG, PH, PL, PT, RO, RU, SC, SD, SE, SG, SK, SL, SY, TJ, TM, TN, TR, TT, TZ, UA, UG, US, UZ, VC, VN, YU, ZA, ZM, ZW.
- (84) Designated States (unless otherwise indicated, for every kind of regional protection available): ARIPO (BW, GH, GM, KE, LS, MW, MZ, NA, SD, SL, SZ, TZ, UG, ZM, ZW), Eurasian (AM, AZ, BY, KG, KZ, MD, RU, TJ, TM), European (AT, BE, BG, CH, CY, CZ, DE, DK, EE, ES, FI, FR, GB, GR, HU, IE, IT, LU, MC, NL, PL, PT, RO, SE, SI, SK, TR), OAPI (BF, BJ, CF, CG, CI, CM, GA, GN, GQ, GW, ML, MR, NE, SN, TD, TG).

[Continued on next page]

(54) Title: HIGH POWERED LIGHT EMITTER PACKAGES WITH COMPACT OPTICS



(57) Abstract: A light emitter includes a supporting surface, a light source positioned on the spreader region, and an encapsulant positioned on the spreader region to surround the light source. The encapsulant is capable of expanding and contracting along the surface of the spreader region in response to a change in temperature so that forces caused by differences in the coefficient of thermal expansion between the different components is minimized. One or more reflective elements can be positioned proximate to the light source to increase the light emitting efficiency of the light emitter. The reflective elements can include the a reflective layer on the spreader region and/or a reflective layer on a portion of the encapsulant.

WO 2004/100279 A2



**Published:**

— without international search report and to be republished upon receipt of that report

*For two-letter codes and other abbreviations, refer to the "Guidance Notes on Codes and Abbreviations" appearing at the beginning of each regular issue of the PCT Gazette.*

**HIGH POWERED LIGHT EMITTER PACKAGES WITH COMPACT OPTICS**

This application claims the benefit of U.S. Provisional Application Serial No. 60/467,193 filed April 30, 2003.

BACKGROUND OF THE INVENTIONField of the Invention

[0001] This invention relates to light emitters and, more particularly, to light emitter packages with components arranged to withstand thermal stresses.

Description of the Related Art

[0002] Light emitters are an important class of solid-state devices that convert electrical energy to light. One such light emitter is a light emitting diode (LED) which generally includes an active region of semi-conductive material sandwiched between two oppositely doped regions. When a bias is applied across the doped regions, holes and electrons are injected into the active region where they recombine to generate light. The light can be emitted from the active region and through the surfaces of the LED.

[0003] LEDs are generally divided into classes depending on their power rating. Although there is no standard range for the different classes, low power LEDs typically have a power rating in the range of 0.1 Watts to 0.3 Watts, or lower, and high power LEDs typically have a rating in the range of 0.5 Watts to 1.0 Watt, or higher.

[0004] Conventional packaging for low power LEDs typically includes a reflector cup with the LED mounted at

the bottom of the cup. Cathode and anode leads are electrically coupled to the LED to provide power. The cathode lead can extend through the reflector cup and the anode lead can be wire bonded. The main function of the reflector cup is to redirect light emitted in certain directions in order to control the far-field intensity pattern of the LED. The reflector cup can include a highly reflective surface finish and can be plate stamped or metal plated with a metal such as aluminum (Al) or silver (Ag).

[0005] The entire structure can be encased in a transparent, hard encapsulant such as a plastic or epoxy. The encapsulant serves a number of functions. One function is to provide a hermetic seal for the LED chip. In another function, light refracts at the encapsulant/air interface, so that the outside shape of the encapsulant can act as a lens to further control the intensity pattern of the LED.

[0006] One disadvantage of this packaging arrangement, however, is that the LED chip, the reflector cup, and the encapsulant each generally have different coefficients of thermal expansion (CTE). Hence, during operational heating cycles they expand and contract at different rates, which can place a high mechanical stress on the device. In particular, epoxies and silicones typically used for the encapsulant have a CTE that is very different from the CTE of metals or ceramics. The CTE mismatch can also be exacerbated by constraints imposed by the manufacturing flow, such as during epoxy curing. In addition, these packages do not dissipate heat from the LED chip efficiently as they lack good thermal properties. However, because the LED operates at low power, the amount of heat

it produces is relatively low so that the differences in CTE do not result in unacceptable failure rates.

[0007] High power LEDs, however, are generally larger, use larger packaging components, and generate higher amounts of heat. As a result, the CTE mismatch has a much larger impact on reliability and if the low-power LED type packaging is used, the differences in CTE for the packaging components can result in unacceptable failure rates. One of the most common failures is fracturing or cracking of the encapsulant.

[0008] High power LED packages have been introduced having a heat spreader that serves as a rigid platform for the remainder of the components, and is made of a material with high thermal conductivity such as a metal or ceramic that helps to radiate heat away from the LED chip. A reflector cup is mounted to the platform with the LED chip mounted at the bottom of the cup. The LED chip is contacted by wire bonds from the rigid platform. The reflector cup, LED chip and wire bonds are encased in an optically clear material that provides environmental protection. To compensate for the different coefficients of thermal expansion (CTE) of the package components, the optically clear material can include a soft gel such as silicone. As the different components expand and contract through thermal cycles, the soft gel readily deforms and compensates for the different CTEs.

[0009] However, soft gel is not as robust as plastics, epoxies, and glass, and cannot be used in some harsh environments without a coating or cover to act as a hermetic seal, which adds complexity to the LED fabrication process. The soft gel also tends to absorb water, which

can shorten the LED's lifespan. It is also more difficult to shape soft gels to control the emission pattern of the LED package.

[0010] Other high power LED packages have been introduced that utilize a hard epoxy encapsulant, with one such device not utilizing a reflector cup inside the encapsulant. Instead, a second region is included on the heat spreader, with a section of the second region stamped, molded or etched to form a depression that can be coated with a reflective material. The LED chip is then placed at the base of the depression and is contacted. A hard epoxy or silicone fills the depression, covering the LED and any wire bonds. This arrangement reduces, but does not eliminate, the fractures and cracking of the epoxy or silicone encapsulant. This arrangement can also suffer from a different problem of the epoxy or silicone encapsulant delaminating and peeling away from the surfaces of the depression through the LED's thermal cycles.

[0011] U.S. Patent No. 6,274,924 to Carey et al. discloses another high power LED package that includes a heat sinking slug that is inserted into an insert molded leadframe. The slug can include a reflector cup with the LED chip and thermally conductive submount arranged at the base of the cup. Metal leads are electrically and thermally isolated from the slug. An optical lens is added by mounting a thermoplastic lens over the slug. The lens can be molded to leave room for a soft encapsulant between the LED and the inside surface of the lens. This invention claims to operate reliably under high power conditions, but is complex, difficult to manufacture, and expensive. The thermoplastic lens also does not survive high temperatures

typically used for the process of soldering LEDs to a printed circuit board.

#### SUMMARY OF THE INVENTION

[0012] The present invention seeks to provide LED packages that are particularly adapted to use with high power LEDs and are arranged to reduce the LED package failures due to the differences in the CTE for the package components. The LED packages are also simple, flexible, and rugged.

[0013] One embodiment of a light emitter according to the present invention comprises a substantially supporting surface, a light source positioned on the supporting surface, and an encapsulant positioned on the supporting surface. The encapsulant surrounds the light source and is capable of expanding and contracting in response to a change in temperature, constrained only by adhesion to said planar support surface.

[0014] Another embodiment of a light emitter according to the present invention comprises a heat spreader and a light source positioned in thermal contact with a substantially planar surface of the heat spreader. The heat spreader provides support for said light source and an encapsulant is positioned to surround the light source, with the encapsulant capable of expanding and/or contracting in response to a change in temperature constrained only by adhesion to said planar surface. A first reflective element is positioned to reflect light from the light source, the reflective element being integrated with at least one of the heat spreader and the encapsulant.

[0015] One embodiment of an optical display according to the present invention comprises a heat spreader with a substantially planar surface. A plurality of light emitters are positioned on the planar surface with each light emitter comprising a light source positioned in thermal contact with the heat spreader. An encapsulant is positioned on the heat spreader to surround the light source with the encapsulant being capable of expanding and contracting in response to a change in temperature constrained only by adhesion to said planar surface. Each light emitter comprises at least one reflective element positioned on the heat spreader and/or said encapsulants to increase the light emitting efficiency of the display.

[0016] One embodiment of a method of fabricating a light emitter includes providing a substantially planar supporting surface and providing a light source positioned on the substantially planar supporting surface. An encapsulant is provided positioned on the supporting surface and over the light source so that the encapsulant can expand and contract with changes in temperature constrained only by adhesion to said planar surface.

[0017] These and other further features and advantages of the invention would be apparent to those skilled in the art from the following detailed description, taking together with the accompanying drawings, in which:

#### BRIEF DESCRIPTION OF THE DRAWINGS

[0018] FIG. 1 is a simplified sectional view of a light emitter according to the present invention;



[0019] FIG. 2 is a simplified sectional view of another embodiment of a light emitter according to the present invention;

[0020] FIG. 3 is a simplified sectional view of another embodiment of a light emitter according to the present invention having a shaped lens;

[0021] FIG. 4 is a simplified sectional view of another embodiment of a light emitter according to the present invention having a reflective surface on the shaped lens;

[0022] FIG. 5 is a simplified sectional view of another embodiment of a light emitter according to the present invention having a bullet shaped lens;

[0023] FIG. 6 is a simplified sectional view of another embodiment of a light emitter according to the present invention having a concave shaped lens;

[0024] FIG. 7 is a simplified sectional view of another embodiment of a light emitter according to the present invention having a mushroom shaped lens;

[0025] FIG. 8 is a simplified sectional view of another embodiment of a light emitter according to the present invention having a circular spherical shaped lens; and

[0026] FIG. 9 is a simplified flowchart illustrating a method of fabricating a light emitter according to the present invention.

#### DETAILED DESCRIPTION OF THE INVENTION

[0027] FIG. 1 illustrates one embodiment of a light emitter 10 in accordance with the present invention. Emitter 10 includes a heat spreader 12 with a light source 14 is positioned on and in thermal contact with the heat

spreader region 12. Spreader region 12 provides a support structure for holding light source 14 and is at least partially made of a high thermal conductivity material to facilitate heat flow away from light source 14. The preferred heat spreader is made of a high thermal conductive material such as copper (Cu), aluminum (Al), aluminum nitride (AlN), aluminum oxide (AlO), silicon (Si), silicon carbide (SiC) or combinations thereof.

[0028] Light source 14 comprises an LED, although it can include other light emitters, such as a solid-state laser, a laser diode, or an organic light emitting diode, among others. Power to light source 14 can be provided from first and second wire bonds 16, 18 with a bias applied across the light source 14, and in the embodiment shown the wire bonds apply a bias across oppositely doped layers of the LED light source to cause it to emit light. In other embodiments according to the present invention only one wire bond can be used, with the light source 14 also contacted through the spreader region 12. In still other embodiments, the light source 14 is contacted only through the spreader region 12.

[0029] Emitters according to the present invention can be included in systems designed to emit light either as a single light source or in a display. Emitter according to the invention can also include a single light source or an array of light sources which emit the same or different wavelengths of light. Emitter 10 and the emitters in the following figures are shown with one light source for simplicity and ease of discussion. It is understood, however, that emitters according to the present invention can be arranged in many different ways.

[0030] A transparent encapsulant 20 is positioned to surround light source 14 and is provided to encapsulate and hermetically seal light source 14 and wire bonds 16, 18. Encapsulant 20 is typically positioned on the top surface of spreader region 20. Encapsulant 20 can be made of many different hard and optically clear materials such as epoxy, silicone, glass, or plastic, and can be a pre-molded lens or formed directly over light source 14. Pre-molded encapsulants or lenses can be fabricated using techniques, such as injection molding, and then bonded to heat spreader 20.

[0031] The spreader region 12 can also include a reflective layer 22 on the same surface as the light source 14, with the reflective layer 22 at least covering substantially all of the surface not covered by the light source 14. In the embodiment shown, the reflective layer 22 covers the entire surface such that part of said reflective layer is sandwiched between the light source 14 and the spreader region 12. Light source 14 emits light omnidirectionally with light paths 1, 2, 3, 4 and 5 representing a few of the possible light paths from the light source. Light paths 1, 2 and 3 extend from light source 14 and through encapsulant 20. Light can also flow along light paths 4 and 5 which extend from light source 14 to the reflective layer 22 and through encapsulant 20. Reflective layer 22 can reflect light from light source 14 to increase the optical efficiency of emitter 10. Reflective layer 22 can comprise many reflective materials reflective at the wavelength of interest, such as aluminum (Al), silver (Ag), or a combination thereof.

[0032] Emitter 10 has many advantages, one being that it is less complex and, consequently, costs less than conventional devices. The complexity is reduced in one way by combining the reflector layer 22 with spreader region 12 which eliminates the need to have a reflector structure separate from encapsulant 20 and heat spreader 12, which allows for a simplified manufacturing process.

[0033] Thermal stresses are also reduced because the reflector function is integrated with other components included in emitter 10. Hence, there are fewer components expanding and contracting against each other at different rates. As a result, light source 14 can operate more reliably at higher power and, consequently, higher temperature with less risk of having emitter 10 fail. Another cause of failure can be the fracturing or cracking of encapsulant 20 associated with CTE mismatch between the different materials used. However, the probability of this happening is reduced by the arrangement of emitter 10. The surface between encapsulant 20 and spreader region 12 is planar so that encapsulant 20 is only constrained at one surface. This puts less stress on wire bonds 16 and/or 18 which can cause them to break or loosen and reduce the useful lifetime of emitter 10.

[0034] Encapsulant 20 can include hard and high melting point materials, such as glass, to provide a package which is hermetically sealed because the curing process and temperature cycles associated with these materials is no longer a problem. Emitter 10 also provides for greater flexibility in the choice of materials which can be used for encapsulant 20 and spreader region 22 because they can be matched for adhesion. Hence, the probability of

encapsulant 20 delaminating and peeling away from spreader layer 22 through the emitter's thermal cycles is reduced.

[0035] Another advantage is that light emitter 10 has a smaller footprint so that an array of packages can be positioned closer together. This feature is useful in light displays where it is typically desired to position the packages close together in an array to increase resolution and display quality.

[0036] FIGS. 2 through 8 illustrate additional embodiments of light emitters in accordance with the present invention. It should be noted that the emitters illustrated in the rest of the disclosure include components similar to the components illustrated in FIG. 1 and similar numbering is used with the understanding that the discussion above in conjunction with emitter 10 applies equally well to the emitters discussed in FIGS. 2 through 8.

[0037] FIG. 2 illustrates another embodiment of a light emitter 30 in accordance with the present invention. Emitter 30 includes spreader region 12 and can include a reflective layer 22. Light source 14 is positioned on reflective layer 22 and an encapsulant 40 is positioned to encapsulate and seal light source 14. Encapsulant 40 is shaped around its base to provide an angled surface 42 that reflects sideways directed light emitted from light source 14 by total internal reflection.

[0038] Light paths 6, 7 show two possible light paths from the light source 14, both of which are incident to surface 42. Light paths 6 and 7 can be reflected by total internal reflection (TIR) by surface 42 toward the top of encapsulant 40 along respective light paths 8 and 9. This

reduces the light that is emitted out the sides of encapsulant 40 and increases the light emitted out of the top. As a result, emitter 30 can produce more focused light with better light emission efficiency. It should be noted that light emitted from light source 14 can also be reflected from reflective layer 22 and through encapsulant 40, either directly or indirectly off of surface 42 to further enhance emission efficiency. Light emitter 30 includes all of the features of emitter 10 described above, with the added advantage of more focused light, better optical efficiency.

[0039] FIG. 3 illustrates another embodiment of a light emitter 50 in accordance with the present invention, which is similar to emitter 30 in FIG. 2. Emitter 50 includes spreader region 12 with a reflective layer 22 on the spreader region 12. A light source 14 is positioned on reflective layer 22 and an encapsulant 60 positioned to surround light source 14 and to provide hermetic sealing. Encapsulant 60 also comprises an angled surface 42 with reflective layer 64 applied to angled surface 42. Support region 49 is positioned adjacent to second reflective layer 64 and spreader region 22.

[0040] Second reflective layer 64 reflects most or all of the light incident on the angled surface 42 including the light that does not experience TIR and would otherwise pass through angled surface 42. This further focuses the light from light source 14 toward the top of encapsulant 60 and increases the optical efficiency by increasing the amount of emitted light. Second reflective layer 64 can be made of different materials with different reflectivities, such as silver (Ag), aluminum (Al), titanium oxide (TiO),

white resin, or combinations thereof. Second reflective layer 64 can be applied using many different methods such as painting, plating, or deposition and can also be applied before or after encapsulant 60 is positioned over light source 14. An additional advantage of layer 64, which is opaque to light, is that it allows optional barrier region 49 to be included for mechanical support and environmental protection without degrading the light efficiency of emitter 50. The material used for region 49 should be chosen so that it does not constrain the encapsulant 60 under thermal cycling.

[0041] FIG. 4 illustrates another embodiment of light emitter 70 in accordance with the present invention, which is similar to emitter 10 of FIG. 1. Emitter 70 includes spreader region 12, light source 14, and a reflective layer 22. Emitter 70 also comprises an encapsulant 80 that is a preformed lens having a cavity 81 in its base. Like the encapsulants described above, lens 80 can be made of an epoxy, silicone, glass, or plastic and can be fabricated using methods such as injection molding. Encapsulant 80 is mounted over light source 14 to the top surface of heat spreader 12 with light source 14 and wire bonds 16, 18 arranged in cavity 81. A bonding material 82 fills the space in cavity 81 and holds lens 80 to heat spreader 12. Different types of encapsulants can be used provided they are sized to fit on heat spreader 12 while providing a cavity for light source 14, wire bonds 16, 18 and bonding material 82.

[0042] Bonding material 82 can include different materials such as an epoxy, glue, or silicone gel. The index of refraction of bonding material 82 is preferably

the same as that of encapsulant 80 to minimize reflections between the two materials and can be chosen to obtain a desired light emitting efficiency. Material 82 can be positioned in cavity 81 before encapsulant 80 is positioned over light source 14 or encapsulant 80 can be positioned in place and material 82 can be injected through encapsulant 80 or through a hole (not shown) in heat spreader 12. The hole can then be sealed with a plug made from resin or a similar material.

[0043] This arrangement has the advantages of emitter 10 with added flexibility in the type and shape of encapsulant that can be mounted over light source 14 and heat spreader 12. Different types of lenses can be used provided they are sized on the spreader region 12 while providing a cavity for the light emitter 14, wire bonds 16, 18, and the bonding material 82. If silicone gel is used for material 82, then it can compensate for differences in the CTE of the different materials.

[0044] FIG. 5 illustrates another embodiment of a light emitter 90 in accordance with the present invention. Emitter 90 includes spreader region 12, light source 14, and reflective layer 22. Emitter 90 also includes a hard "bullet shaped" encapsulant 100, which can be a pre-molded lens or an epoxy positioned over light source 14 and shaped. The shape of encapsulant 100 is chosen to refract light along light paths 1, 3, 4, and 5 toward the top of emitter 90 as the light passes out of encapsulant 100 at a surface 121. This light refraction helps to focus the light from light source 14. Light that hits the surface of encapsulant 100 at exactly 90° (i.e. along light path 2) will not be refracted.



[0045] FIG. 6 illustrates another embodiment of a light emitter 110 according to the present invention which also includes a spreader region 12, light source 14, and reflective layer 22. Emitter 110 also includes a "concave" shaped encapsulant 120 that more effectively reflects light internally toward the top of emitter 110 and can also more efficiently refract light passing out of the encapsulant 120 toward the top of the emitter 110. Encapsulant 120 includes an angled surface 122 which is shaped in such a way to increase the focusing power of encapsulant 120 and the light emitting efficiency of emitter 110. The angle and shape of surface 122 can be chosen to obtain a desired gain in focusing the light and to decrease any losses from TIR.

[0046] FIG. 7 illustrates another embodiment of light emitter 130 in accordance with the present invention that comprises spreader region 12, light source 14, wire bonds 16 and 18, and reflective layer 22. Emitter 130 also comprises a mushroom shaped encapsulant 140 having a dome 142 and angled stem 146. Stem 146 can be covered by a second reflective layer 147 such that light from light source 14 that strikes stem 146 along light paths 6 and 7 is reflected toward dome 142 along respective light paths 8 and 9. This arrangement also provides focused light and is more efficient because less light is lost to TIR.

[0047] FIG. 8 illustrates still another embodiment of a light emitter 150 in accordance with the present invention, which includes a spreader region 12, light source 14, and reflective layer 22. Emitter 150 also includes a spherical shape encapsulant 160 that can also include a reflective region 161 on its lower hemisphere to reflect light along

light paths 6 and 7 toward the top of encapsulant 160 along respective light paths 8 and 9. This arrangement also provides focused light and has less TIR losses because of encapsulant 160 and reflective region 64. It is also understood that the encapsulant can be many other detailed shapes in accordance with the present invention.

[0048] FIG. 9 illustrates a flowchart 200 for one embodiment of a method for fabricating a light emitter in accordance with the present invention. The method includes step 201 of providing a spreader region having at least one planar surface with a reflective layer on it, and step 202 includes providing a light source positioned on at least one planar surface. Step 203 comprises providing an encapsulant positioned on the planar surface of the spreader region and over the light source. By being planar the expansion and contraction of the encapsulant with changes in temperature is constrained only at the planar surface.

[0049] The encapsulant can be positioned so that it hermetically seals the light source, where the hermetic seal remains unbroken with changes in temperature. The encapsulant can be positioned so that the relative position of the encapsulant and light source remains unchanged with changes in temperature. The relative position will remain unchanged if there is nothing (i.e. a 3D reflector structure) for the encapsulant to push against as the temperature changes.

[0050] An optional step 204 comprises angling the surface of the encapsulant adjacent to the spreader region to increase the efficiency of the emitter by directing TIR light and refracted light toward the top of the emitter.

[0051] An optional step 205 comprises providing a second reflective element positioned on the angled surfaces to increase the emission efficiency of the emitter. The second reflective element can be formed by using one of painting, plating, and deposition. An optional step 207 can comprise positioning a barrier region adjacent to the supporting surface and a base of the encapsulant. The barrier region can form a better seal for the light source. It should be noted that the steps illustrated in flowchart 200 can be performed in a different order and that different steps can be used in methods according to the present invention.

[0052] Although the present invention has been described in considerable detail with reference to certain preferred configurations thereof, other versions are possible. The lenses described above can have many different shapes and can be made of many different materials. Each of the light sources described above can further comprise a submount to provide protection from electrostatic discharge (ESD). In each embodiment above, the heat spreader can be etched to provide a hole to house the light source such that the light source does not extend above the top surface of the heat spreader. The encapsulant could then have a flat base to mount to the heat spreader, over the light source.

[0053] Therefore, the embodiments of the invention described herein are exemplary and numerous modifications, variations and rearrangements can be readily envisioned to achieve substantially equivalent results, all of which are intended to be embraced within the spirit and scope of the invention as defined in the appended claims.

**WE CLAIM:**

1. A light emitter, comprising:
  - a substantially planar supporting surface;
  - a solid state light source positioned on said supporting surface; and
  - an encapsulant positioned on said supporting surface surrounding said light source, said encapsulant being capable of expanding and contracting in response to a change in temperature and constrained only by adhesion to said planar supporting surface.
2. The emitter of claim 1, further comprising a reflective element integrated with at least one of said supporting surface and said encapsulant.
3. The emitter of claim 1, wherein a surface of said light source is adjacent to said supporting surface, said encapsulant covering all other surfaces of said light source.
4. The emitter of claim 1, wherein said encapsulant hermetically seals said light source, said hermetic seal remaining unbroken with the change in temperature.
5. The emitter of claim 1, further comprising a barrier region positioned adjacent to said supporting surface at the base of said encapsulant, said barrier region forming a seal between said surface and said encapsulant.

6. The emitter of claim 1, wherein said supporting surface is planar so that expansion and contraction of said encapsulant is constrained only at said supporting surface.

7. The emitter of claim 1, wherein said supporting surface is reflective to the light emitted by said light source.

8. The emitter of claim 1, wherein said encapsulant is shaped around its base to provide an angled surface that reflects some of the light emitted from said light source.

9. The emitter of claim 8, wherein said encapsulant is shaped so that said reflected light flows through a focusing surface of said encapsulant.

10. The emitter of claim 8, wherein said angled surface includes a reflective coating which is reflective to said light emitted by said light source.

11. The emitter of claim 1, wherein said supporting structure comprises a highly thermally conductive spreader region to draw heat away from said light source.

12. The emitter of claim 1, wherein said light source comprises a light emitting diode.

13. A light emitter, comprising:  
a heat spreader;

a light source positioned in thermal contact with a substantially planar surface of said heat spreader with said heat spreader providing support for said light source;

an encapsulant positioned to surround said light source, said encapsulant being capable of expanding and/or contracting in response to a change in temperature constrained only by adhesion to said planar surface; and

a first reflective element positioned to reflect light from said light source, said reflective element being integrated with at least one of said heat spreader and said encapsulant.

14 The emitter of claim 13, wherein said first reflective element includes an angled surface on the base of said encapsulant, said angled surface being capable of reflecting light from said light source to increase the light emitting efficiency of said emitter.

15. The emitter of claim 14, further comprising a second reflective element on said angled surface.

16. The emitter of claim 13, wherein said encapsulant is one of bullet shaped, concave shaped, and mushroom shaped.

17. The emitter of claim 13, wherein said encapsulant includes a second reflective element positioned to increase the reflectivity of said first reflective element.

18. The emitter of claim 17, wherein said second reflective element includes at least one of silver (Ag),

aluminum (Al), titanium oxide (TiO), white resin, and another material region reflective at the wavelengths of interest.

19. The emitter of claim 13, wherein said encapsulant includes a preformed lens having a cavity in its base, said light source being positioned in said cavity.

20. The emitter of claim 19, further comprising a bonding material which fills the space in said cavity and holds said lens to said heat spreader, the index of refraction of said bonding material being chosen to obtain a desired light emitting efficiency.

21. The emitter of claim 20, wherein said bonding material includes at least one of epoxy, glue, silicone gel, and another material which has an index of refraction chosen to increase the light emitting efficiency of said emitter.

22. The emitter of claim 20, wherein said bonding material is chosen to compensate for differences in the coefficient of thermal expansion between said encapsulant, light source, and/or heat spreader.

23. The emitter of claim 13, wherein said heat spreader includes at least one of copper (Cu), aluminum (Al), aluminum nitride (AlN), aluminum oxide (AlO), silicon (Si), silicon carbide (SiC) and another high thermal conductivity material which can dissipate heat away from said light source.

24. The emitter of claim 13, wherein said first reflective element includes the surface of said heat spreader.

25. The emitter of claim 24, wherein said the surface of said heat spreader includes at least one of aluminum (Al), silver (Ag), and another material reflective at the wavelengths of interest.

26. The emitter of claim 13, wherein further including a barrier region positioned proximate to said first reflective element, said barrier region providing a hermetic seal between said encapsulant and heat spreader.

27. An optical display, comprising:

a heat spreader with a substantially planar surface;

a plurality of light emitters positioned on said substantially planar surface, each light emitter comprising a light source positioned in thermal contact with said heat spreader;

an encapsulant positioned on said heat spreader to surround said light source, said encapsulant being capable of expanding and contracting in response to a change in temperature, constrained only by adhesion to said substantially planar surface; and

at least one reflective element positioned on said heat spreader and/or one or more encapsulants



to increase the light emitting efficiency of said display.

28. A method of fabricating a light emitter, comprising:

providing a substantially planar supporting surface;

providing a light source positioned on said planar supporting surface; and

providing an encapsulant positioned on said supporting surface and over said light source so that said encapsulant can expand and contract with changes in temperature, constrained only by adhesion to said planar surface.

29. The method of claim 28, further including a step of providing a first reflective element positioned to increase the optical efficiency of said light emitter.

30. The method of claim 28, wherein the step of providing said first reflective element includes providing an angled surface on the base of said encapsulant.

31. The method of claim 28, further including a step of providing a second reflective element positioned to increase the reflectivity of said angled surface.

32. The method of claim 31, wherein the step of providing said second reflective element includes a step of forming a reflective material region by using one of painting, plating, and deposition.

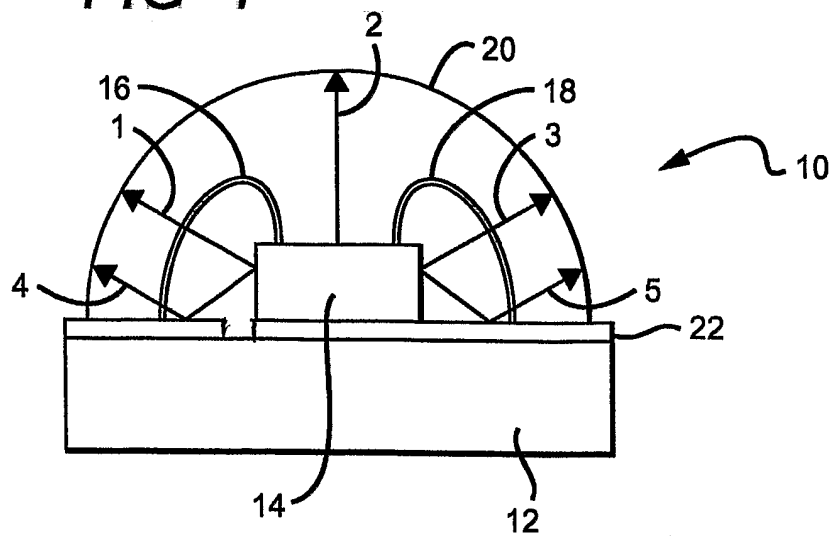
33. The method of claim 29, wherein the step of providing said first reflective element includes a step of providing a heat spreader with a reflective surface corresponding to said supporting surface.

34. The method of claim 28, wherein the step of providing said encapsulant includes a step of positioning said encapsulant so that it hermetically seals said light source, said hermetic seal remaining unbroken with the change in temperature.

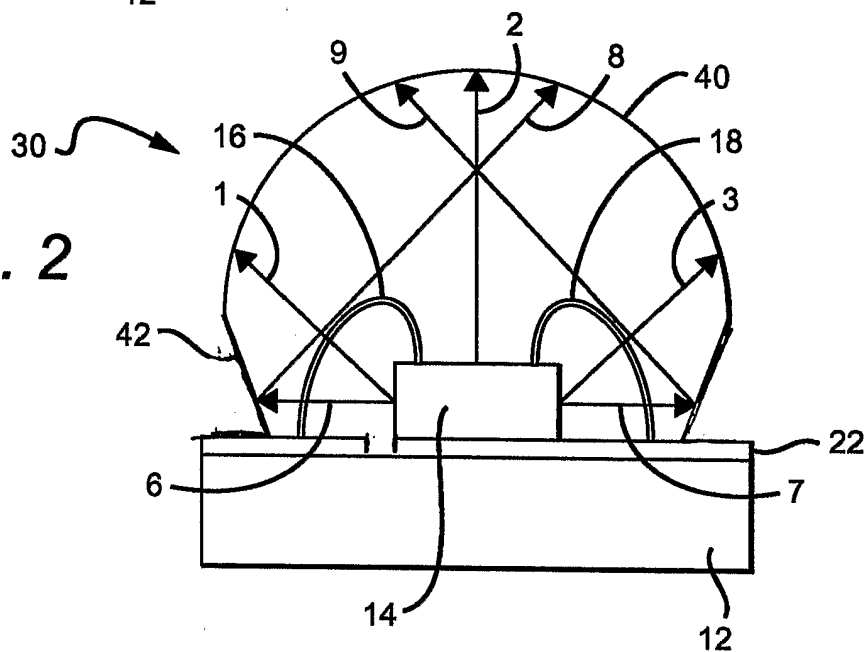
35. The method of claim 28, wherein the step of providing said encapsulant includes a step of positioning said encapsulant so that the relative position of said encapsulant and light source remains unchanged with changes in temperature.

36. The method of claim 28, further including a step of positioning a barrier region adjacent to said supporting surface and a base of said encapsulant, said barrier region forming a seal for said light source.

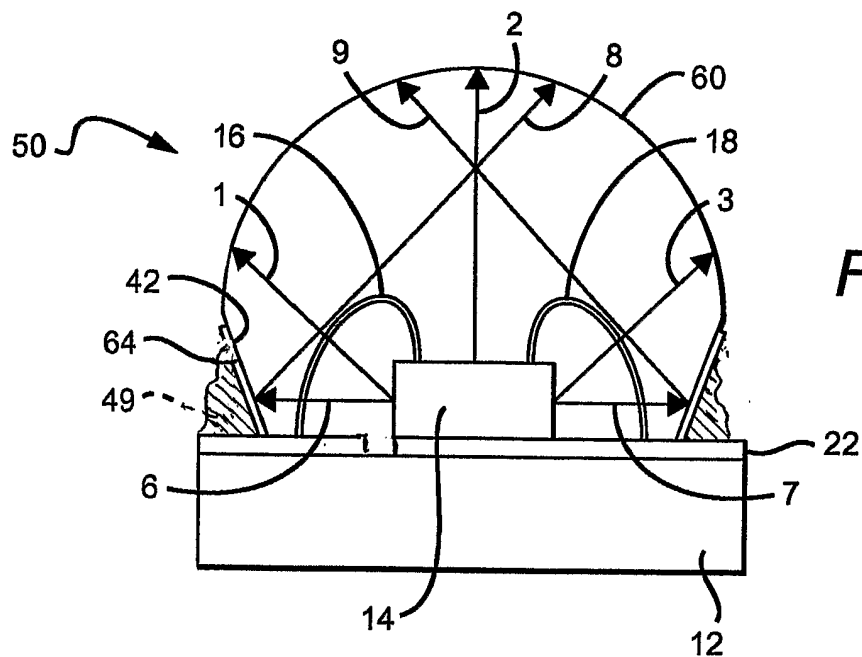
**FIG 1**

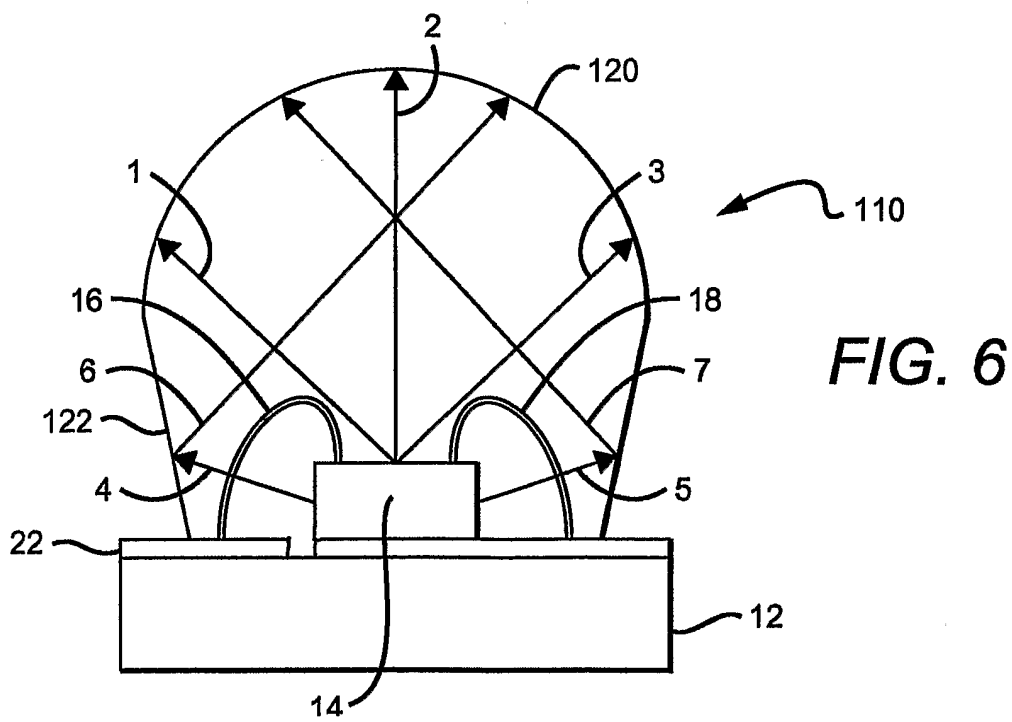
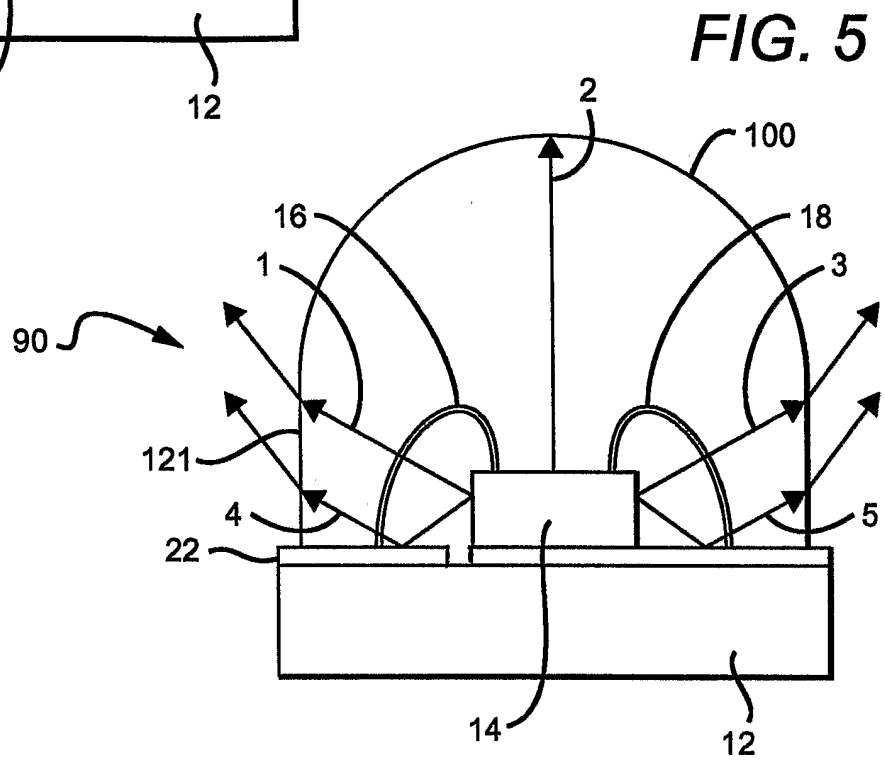
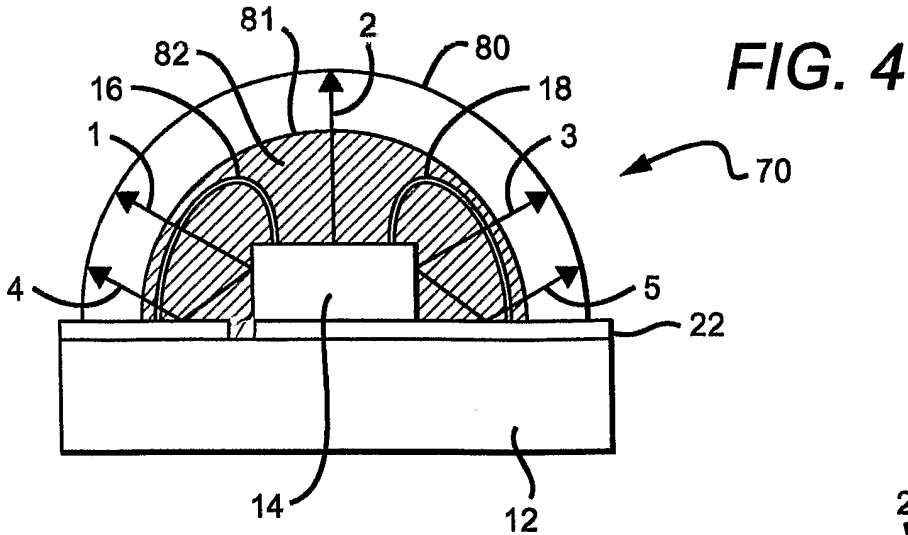


**FIG. 2**



**FIG. 3**





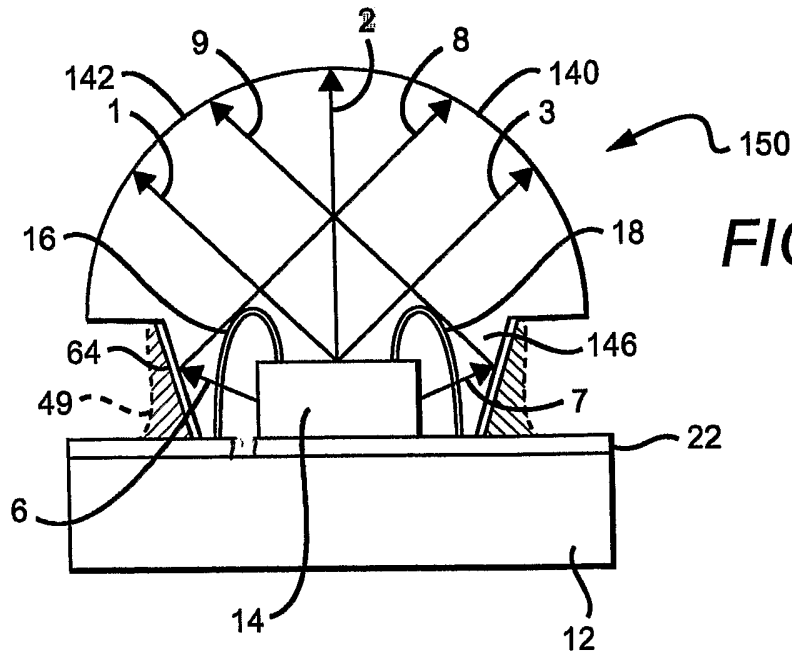


FIG. 7

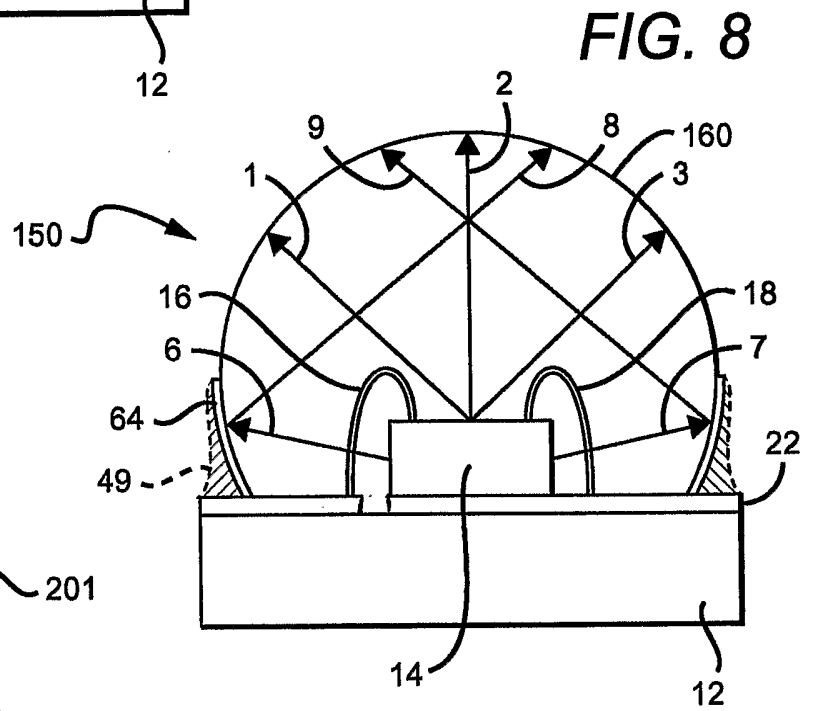


FIG. 8

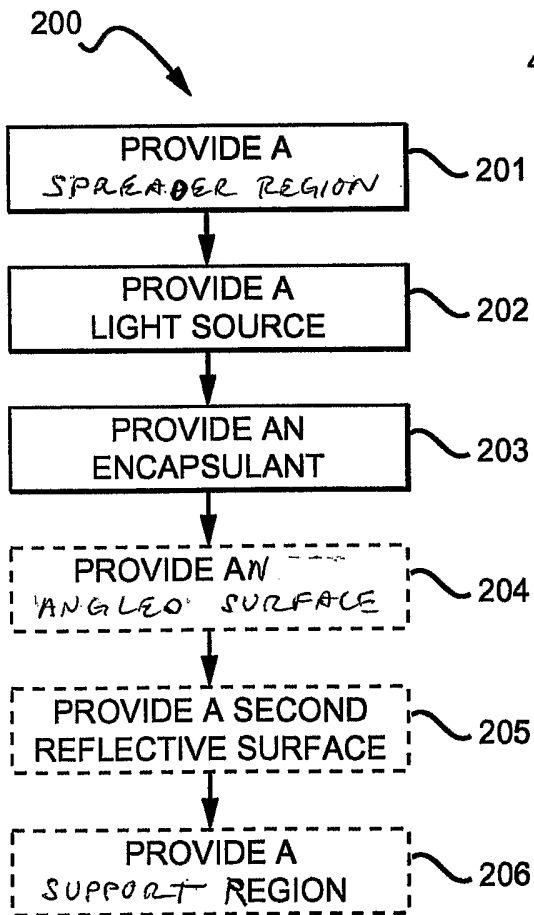


FIG. 9