



INTERNATIONAL APPLICATION PUBLISHED UNDER THE PATENT COOPERATION TREATY (PCT)

(51) International Patent Classification ⁷ : B01D 53/56, 53/60, 53/32, B01J 19/12, B01D 53/92, F01N 3/01	A1	(11) International Publication Number: WO 00/43106 (43) International Publication Date: 27 July 2000 (27.07.00)
(21) International Application Number: PCT/US00/01589 (22) International Filing Date: 21 January 2000 (21.01.00) (30) Priority Data: 60/116,948 21 January 1999 (21.01.99) US (71) Applicant (for all designated States except US): TIBERIAN INDUSTRIES, INC. [US/US]; 1690B Empire Avenue, East Point, GA 30344 (US). (72) Inventors; and (75) Inventors/Applicants (for US only): GRAVITT, Alan, C. [US/US]; 2129 Lyle Road, College Park, GA 30337 (US). ISAAC, Thomas, L. [US/US]; 200 Lamar Smith Drive, Newnan, GA 30263 (US). (74) Agents: MEUNIER, Andrew, T. et al.; Alston & Bird LLP, P.O. Drawer 34009, Charlotte, NC 28234-4009 (US).	(81) Designated States: AE, AL, AM, AT, AT (Utility model), AU, AZ, BA, BB, BG, BR, BY, CA, CH, CN, CR, CU, CZ, CZ (Utility model), DE, DE (Utility model), DK, DK (Utility model), DM, EE, EE (Utility model), ES, FI, FI (Utility model), GB, GD, GE, GH, GM, HR, HU, ID, IL, IN, IS, JP, KE, KG, KP, KR, KZ, LC, LK, LR, LS, LT, LU, LV, MA, MD, MG, MK, MN, MW, MX, NO, NZ, PL, PT, RO, RU, SD, SE, SG, SI, SK, SK (Utility model), SL, TJ, TM, TR, TT, TZ, UA, UG, US, UZ, VN, YU, ZA, ZW. Published <i>With international search report.</i> <i>Before the expiration of the time limit for amending the claims and to be republished in the event of the receipt of amendments.</i>	
(54) Title: A METHOD AND APPARATUS FOR OXIDATION OF NITRIC OXIDE USING IRRADIATED OXIDIZING COMPOUNDS		
(57) Abstract <p>The present invention is a method and apparatus that uses microwave energy to produce highly active forms of oxidizing compounds that react with nitric oxide and other lower valence components in gaseous streams to form compounds that can be readily removed by conventional pollution abatement processes. An oxidation chamber is used to simultaneously expose the oxidizing compound to microwave energy and contact it with the gaseous stream. The present invention provides a reliable, cost effective means of oxidizing pollutants into forms that can be effectively removed using existing pollution abatement devices.</p>		

FOR THE PURPOSES OF INFORMATION ONLY

Codes used to identify States party to the PCT on the front pages of pamphlets publishing international applications under the PCT.

AL	Albania	ES	Spain	LS	Lesotho	SI	Slovenia
AM	Armenia	FI	Finland	LT	Lithuania	SK	Slovakia
AT	Austria	FR	France	LU	Luxembourg	SN	Senegal
AU	Australia	GA	Gabon	LV	Latvia	SZ	Swaziland
AZ	Azerbaijan	GB	United Kingdom	MC	Monaco	TD	Chad
BA	Bosnia and Herzegovina	GE	Georgia	MD	Republic of Moldova	TG	Togo
BB	Barbados	GH	Ghana	MG	Madagascar	TJ	Tajikistan
BE	Belgium	GN	Guinea	MK	The former Yugoslav Republic of Macedonia	TM	Turkmenistan
BF	Burkina Faso	GR	Greece			TR	Turkey
BG	Bulgaria	HU	Hungary	ML	Mali	TT	Trinidad and Tobago
BJ	Benin	IE	Ireland	MN	Mongolia	UA	Ukraine
BR	Brazil	IL	Israel	MR	Mauritania	UG	Uganda
BY	Belarus	IS	Iceland	MW	Malawi	US	United States of America
CA	Canada	IT	Italy	MX	Mexico	UZ	Uzbekistan
CF	Central African Republic	JP	Japan	NE	Niger	VN	Viet Nam
CG	Congo	KE	Kenya	NL	Netherlands	YU	Yugoslavia
CH	Switzerland	KG	Kyrgyzstan	NO	Norway	ZW	Zimbabwe
CI	Côte d'Ivoire	KP	Democratic People's Republic of Korea	NZ	New Zealand		
CM	Cameroon			PL	Poland		
CN	China	KR	Republic of Korea	PT	Portugal		
CU	Cuba	KZ	Kazakstan	RO	Romania		
CZ	Czech Republic	LC	Saint Lucia	RU	Russian Federation		
DE	Germany	LI	Liechtenstein	SD	Sudan		
DK	Denmark	LK	Sri Lanka	SE	Sweden		
EE	Estonia	LR	Liberia	SG	Singapore		

A METHOD AND APPARATUS FOR OXIDATION OF NITRIC OXIDE USING IRRADIATED OXIDIZING COMPOUNDS

FIELD OF THE INVENTION

The present invention relates to methods and apparatus for oxidizing nitric oxide (NO) present in a gas stream and converting SO₃, VOCs, and other pollutants using oxidizing compounds thus forming compounds that can be more readily removed from the gas stream by conventional means. In particular, the present invention employs microwave energy to activate oxidizing compounds that oxidize NO and that convert other gaseous components into more desirable compounds to allow removal of these gaseous components using pollution control devices such as wet scrubber systems.

BACKGROUND OF THE INVENTION

Carbonaceous fuels such as coal, oil, and other low molecular weight hydrocarbons are widely used in a range of combustion operations including utility boilers, industrial furnaces, and the like. Combustion of these carbonaceous fuels at high temperatures is considered to be beneficial due to a reduction in carbon monoxide emission and more efficient combustion. However, high temperature combustion also promotes the production of nitrogen oxides, also referred to as NO_x, in the form of nitric oxide, nitrogen dioxide and the like. Nitrogen oxides are known to form ground level ozone, to comprise a major irritant in smog and to be a significant contributor to acid rain.

Typically, nitrogen oxides can be present in effluent combustion gas mixtures at concentrations ranging from about 200 to about 1,000 parts per million (ppm). Nonetheless, these relatively small concentrations are significant due to the rapid rate at which effluent combustion gases are

produced. For example, a typical 500 megawatt power plant emits approximately 1,000,000 cubic feet per minute of combustion gases into the atmosphere.

5 The detrimental impacts of effluent emissions continues to pose a significant environmental concern. For example, despite efforts to the contrary, ground level ozone concentrations still exceed federal guidelines in many urban areas in the United States. Under the Clean Air Act and its amendments, such ozone nonattainment areas must implement stringent NO_x emissions regulations. These minimal emissions levels are attainable only by
10 treatment of the flue gases exiting the combustion chamber.

The effluent streams of many large utility boilers are currently fitted with extensive scrubbing systems, designed for the removal of sulfur dioxides. It would be highly advantageous to use this existing scrubbing equipment to remove NO_x from the effluent, as well. Unfortunately, scrubbing processes are
15 generally only effective at scrubbing higher valence nitrogen oxides, such as nitrogen dioxide.

A variety of techniques have been proposed to oxidize nitric oxide and other oxidizable pollutants. For example, nitric oxide can be reacted with an oxidizing compound, such as hydrogen peroxide, particularly at elevated
20 temperatures. In particular, it is known in the art that hydrogen peroxide can be injected directly into either the combustion chamber or the exiting flue gases.

However, direct injection of hydrogen peroxide is problematic. Direct injection of hydrogen peroxide into the combustion chamber can suppress the
25 combustion temperature, resulting in a loss of combustion efficiency. Also, direct injection of hydrogen peroxide into the combustion chamber can result in the decomposition of a significant percentage of the hydrogen peroxide, thus reducing the quantity of hydrogen peroxide available to participate in the oxidation reaction. In contrast, injection of hydrogen peroxide into the flue
30 gases can reduce the reactivity of the hydrogen peroxide, due to the lower temperature of the effluent gas traveling down the flue. In situ heating methods, such as spraying the hydrogen peroxide onto a heated surface placed within the flue, e.g. a hot plate, can aid in the vaporization and reactivity of

hydrogen peroxide. However, such in situ contact heating methods also tend to decompose a large percentage of the injected hydrogen peroxide.

SUMMARY OF THE INVENTION

The present invention provides a method and apparatus that uses highly
5 reactive forms of oxidation compounds to oxidize lower valence compounds
such as nitric oxide, from gaseous streams, particularly combustion effluent
streams, without sacrificing combustion temperature or decomposing
significant amounts of the oxidant. Other compounds that may be converted in
accordance with the invention include SO₃ and volatile organic compounds.
10 The present invention yields oxidized effluent components that can be readily
removed by conventional pollution abatement processes such as wet scrubbing.
This invention is based in part on the discovery that the reactivity of oxidizing
compounds, such as hydrogen peroxide, can be increased by irradiation with
microwave energy without inducing significant decomposition of the oxidizing
15 compound or loss of combustion efficiency.

In one particularly advantageous aspect of the invention, a method for
oxidizing nitric oxide is provided including the steps of introducing an
oxidizing compound into an oxidation chamber, activating the oxidizing
compound by exposing the oxidizing compound to microwave energy, and
20 contacting the activated oxidizing compound with a gaseous stream containing
nitric oxide to convert the nitric oxide into a scrubbable form of nitrogen oxide
such as nitrogen dioxide. The oxidizing compound can be dissolved in an
oxidizing solution. The oxidizing compound can be introduced into the
oxidation chamber by a variety of processes including nebulizing, using a
25 wicking system, or combinations thereof. The activated oxidizing compound
can be in the form of a vapor, gas, or free radical. In one particularly
advantageous embodiment, the oxidizing compound is hydrogen peroxide. In
addition, the oxidation process can be optimized through use of a closed loop
system that monitors the residual nitric oxide in the oxidized gas stream and
30 controls the amount of oxidizing solution introduced into the oxidation
chamber and/or the microwave energy input. The oxidized nitric oxide formed
by the methods of the present invention can then be removed from the oxidized
gas stream by processes such as wet scrubbing.

The invention further relates to an apparatus for performing the methods of the present invention. In one particularly advantageous embodiment, an apparatus for oxidizing a nitric oxide-containing gaseous stream is provided, including an oxidation chamber for contacting nitric oxide with an activated oxidizing compound, a corrosion shield that lines the oxidation chamber, at least one distributor to introduce the oxidizing compound into the oxidation chamber, and at least one microwave generator. The oxidation chamber can optionally be fitted with baffles for facilitating the mixing of the nitric oxide-containing gaseous stream and the activated oxidizing compound. In one advantageous embodiment, the oxidation chamber is comprised of a cylindrical member.

Yet another aspect of the invention relates to an effluent gas oxidation system for forming highly activated oxidizing compounds, such as hydrogen peroxide, in a compact system that will easily allow retrofitting of existing exhaust gas piping and stacks. In addition, aspects of the present invention are directed to an effluent gas emission system comprising a combustion process flue into which an effluent gas oxidation system has been secured upstream of a wet scrubber. A benefit of the present invention is that the existing effluent gas flues of combustion processes can be retrofitted with the present gas oxidation system, thus improving pollution abatement with minimal modifications to existing capital.

The present invention thus provides a reliable, cost effective means of oxidizing flue gas pollutants, such as nitric oxide, using activated forms of oxidizing compounds. These oxidized flue gases can then be effectively removed from the gas stream using existing pollution abatement devices such as wet scrubbers.

Further understanding of the processes and systems of the invention of the invention will be understood with reference to the brief description of the drawings and detailed description which follows herein.

30

BRIEF DESCRIPTION OF DRAWINGS

Aspects of the invention are illustrated in the following drawings. The elements of the drawings are not necessarily drawn to scale, emphasis instead being placed on clearly illustrating principles of the invention.

5 Figure 1 illustrates a cutaway side schematic view of a flue containing an apparatus for oxidizing a nitric oxide-containing gaseous stream in accordance with one embodiment of the present invention that uses a nebulizer as the oxidizing compound distributor.

10 Figure 2 illustrates a top sectional schematic view of an apparatus for oxidizing a nitric oxide-containing gaseous stream in accordance with one embodiment of the present invention that uses a nebulizer as the oxidizing compound distributor.

Figures 3 and 4 illustrate top and side sectional schematic views of another aspect of the invention that uses a wicking system as the oxidizing compound distributor.

15 Figure 5 illustrates a side sectional schematic view of another aspect of the invention that uses a nebulizer in combination with a wicking system as the oxidizing compound distributor.

20 Figure 6 is a cutaway side schematic view of another aspect of the invention that includes a closed loop control system for monitoring exiting nitric oxide concentrations and an oxidizing solution pumping system.

DETAILED DESCRIPTION OF THE INVENTION

The present invention now will be described more fully hereinafter with reference to the accompanying drawings, in which preferred embodiments of the invention are shown. This invention can, however, be embodied in many different forms and should not be construed as limited to the embodiments set forth herein; rather, these embodiments are provided so that this disclosure will be thorough and complete, and will fully convey the scope of the invention to those skilled in the art. Like numbers refer to like elements throughout.

25 Further, the various control, monitoring, and electrical supply lines have been omitted by and large, to improve clarity of presentation and understanding.

30 Referring now to Figure 1, a multicomponent emission system in accordance with one embodiment of the invention is provided. The

multicomponent emission system receives an gas stream **10** that can be generated by any number of combustion processes. Stationary combustion processes capable of producing a suitable gas stream **10** include utility boilers, industrial furnaces, and the like. In alternative aspects, mobile combustion processes such as employed in vehicles can provide the gas stream **10**. Such combustion processes typically produce a significant effluent gas stream **10**, typically transported out of the combustion chamber by means such as a flue **12** and ultimately released into the atmosphere.

The gas stream **10** generally contains a variety of pollutants that must be either removed or abated before the effluent can be returned to the atmosphere. In particular, the gas stream **10**, also commonly referred to as the flue gas, generally includes combustion products, uncombusted fuel and air, as well as undesirable levels of sulfur oxides and nitrogen oxides. Nitrogen oxides are known to include nitric oxide and higher valence nitrogen oxides such as nitrogen dioxide, nitrogen trioxide, NO_3 , and the like. The higher valence nitrogen oxides are readily removed from flue gas streams using absorbent methods such as wet scrubbers. However, the presence of nitric oxide in flue gases is troublesome because it is not readily removed by absorbent methods alone.

The multicomponent emission system of the present invention removes nitric oxide from effluent gaseous mixtures by first converting nitric oxide, a lower valence compound, into a higher valence nitrogen oxide in a gas oxidation system **14**, and subsequently removing the higher valence nitrogen oxide using a conventional absorption method such as a wet scrubber **16**. The present invention can also be used to convert other compounds, such as SO_3 and volatile organic compounds, into more desirable forms (e.g., SO_2 and CO_2). However, for ease of reference, the remainder of the specification will refer to the conversion of nitric oxide by oxidation.

Figures 1 and 2 provide schematic top and side views of one embodiment of the gas oxidation system **14**. In this embodiment, the gas oxidation system **14** is of a size suitable for insertion into a conventional combustion process flue **12**, as shown in Figure 1. As shown in Figures 1 and 2, the gas oxidation system **14** generally includes an oxidation chamber **18**, a

corrosion shield **20** lining the chamber, a distributor such as a nebulizer **22** for introducing an oxidizing solution, and a microwave generator **24**.

The oxidation chamber **18** is preferably formed of a material that is impervious to and reflective of microwave radiation such as a metallic material. In a particularly advantageous embodiment, the oxidation chamber **18** comprises stainless steel. The oxidation chamber **18** can have any configuration. Preferably, the oxidation chamber **18** is cylindrical. In the alternative, the oxidation chamber **18** can be rectangular or of a custom shape suitable to the situation into which the system is integrated. Further, the oxidation chamber **18** can be fitted with two flanges **26**, one attached to each end of the oxidation chamber **18**, for use in securing the gas oxidation system **14** to the walls of the flue **12**. In the advantageous aspect depicted in Figure 1, the gas oxidation system **14** is secured within the flue **12** by means such as bolting the flanges **26** to flue supports **27**. Alternatively, the gas oxidation system **14** can replace a section of the flue **12**. In a further alternative embodiment, the gas oxidation system can be a self supporting or "stand alone" unit.

The environment generated within the oxidation chamber **18** is highly corrosive. Therefore, the oxidation chamber **18** is preferably lined with a chemically resistant corrosion shield **20** that protects the oxidation chamber **18** from the oxidizing compound employed in the present invention. The corrosion shield **20** can include any material that can both withstand the corrosive atmosphere created within the oxidation chamber **18** and transmit microwave energy through its thickness for significant periods of time without deteriorating. In one advantageous embodiment, the corrosion shield **20** is formed from a polymer, and is preferably tetra fluoro ethylene (TEFLON[®]), fiber-reinforced plastic (FRP) or ceramic.

As illustrated in Figures 1 and 4 - 6, the present apparatus can include baffles **28** that are attached to the corrosion shield **20**. The baffles **28** are arranged at suitable angles to the axis of flow to facilitate mixing between the oxidizing solution introduced into the oxidation chamber **18** and the gas stream **10**. The baffles **28** can be formed of any suitable material capable of withstanding the corrosive atmosphere created within the oxidation chamber **18** such as the materials used to form the corrosion shield **20**. In addition, a seal,

such as an elastomeric ring or gasket that conforms to the shape of the flange **26**, can be provided to seal the system to prevent the migration of gases from the system that might constitute a hazard or the migration of gases into the system that might reduce the system efficiency.

5 As noted previously, a distributor introduces the oxidizing solution into the oxidation chamber **18**. In the embodiment provided in Figures 1 and 2, a nebulizer **22** emits an aerosol comprised of oxidizing solution into the oxidation chamber **18**. Nebulizers, known in the art for atomizing liquids, generally introduce fine sprays into gases by breaking liquids passing through
10 the nebulizer into extremely small droplets. In the embodiment illustrated in Figure 2, the nebulizer **22** is located at the cross-sectional and longitudinal centers of the oxidation chamber **18**. However, the nebulizer **22** can be provided in any location that provides adequate mixing between the oxidizing solution and the gas stream **10**. The nebulizer **22** can also be placed at a
15 location upstream of the oxidation chamber **18**. In this embodiment, an element of the gas stream **10** initially encounters the nebulizer **22** and thereafter enters the region interior to the oxidation chamber **18**. Further, a plurality of nebulizers can be employed within the oxidation chamber in a wide variety of configurations.

20 Figures 3 and 4 illustrate the use of an alternative distribution system. In particular, a wicking system **30** introduces oxidizing solution into the oxidation chamber **18**. The wicking system **30** diffuses a vapor comprised of oxidizing solution into the oxidation chamber **18**. The wicking system **30** includes a plurality of wicks **32** that are fixed parallel to the longitudinal axis of
25 the oxidation chamber **18** and that extend into the oxidation chamber **18**. The lower end of the wicks **32** extend down into a tray **34** filled with oxidizing solution and naturally absorb and transport the solution towards the upper end of the wicks **32**. Following its transport, the oxidizing solution diffuses as a vapor from the upper end of the wicks **32** into the oxidation chamber **18**. In the
30 embodiment illustrated in Figures 3 and 4, the wicking system **30** is located at the cross-sectional and longitudinal center of the oxidation chamber **18**. However, the wicking system **30** can be provided in another location that provides adequate mixing between the oxidizing solution and the gas stream **10**. The wicking system **30** can further be provided in a wide variety of

configurations. The wicks **32** are typically formed from any suitable fibrous material capable of withstanding the corrosive oxidizing environment and microwave energy without deteriorating. Fibrous materials suitable for use as wicks **32** include a range of fiber-forming synthetic polymers, particularly
5 polymers such as polypropylene, polyethylene, fiberglass and the like.

In Figure 5, the distributor includes both a nebulizer **22** and a wicking system **30**. In the particular embodiment illustrated in Figure 5, the nebulizer **22** supplies an aerosol of oxidizing compound into the oxidizing chamber **18** slightly downstream of the wicking system **30**. The wicking system **30** in this
10 aspect of the invention catches excess oxidizing solution supplied by the nebulizer **22** and delivers the excess oxidizing solution as a vapor to the oxidizing chamber **18**.

Turning now to the embodiment of Figure 6, oxidizing solution is supplied to the distributor by a pumping system **36** that is capable of supplying
15 the required flow of oxidizing solution under accurate flow metering and further able to withstand the corrosive effects of the oxidizing solution. An oxidizing solution reservoir **38** is provided as a holding tank for the oxidizing solution. An oxidizing solution supply line **40** connects the oxidizing solution reservoir **38** to the oxidizing solution pumping system **36** allowing the flow of
20 oxidizing solution from the oxidizing solution reservoir **38** to the oxidizing solution pumping system **36**. The oxidizing solution pumping system **36** preferably includes a metering pump or a centrifugal pump with variable pumping volume, or can alternatively include a centrifugal pump operated using a demand switch. The suction side of the oxidizing solution pumping
25 system **36** is connected to the oxidizing solution reservoir **38** via the oxidizing solution supply line **40**. The pressure side of the oxidizing solution pumping system is connected to the distributor via the oxidizing solution injection line **42**.

The oxidizing solution includes an oxidizing compound dissolved in a
30 solvent. Oxidizing compounds for use in the present invention include any suitable reactant capable of quickly oxidizing nitric oxide upon activation by microwave energy. Hydrogen peroxide is considered particularly advantageous for use as the oxidizing compound of the present invention. An amount of activated oxidizing compound sufficient to oxidize the nitric oxide

in the gas stream to a higher valence nitrogen oxide is employed. The amount of oxidizing solution required can vary based on process conditions. However, a molar ratio of activated oxidizing compound to nitric oxide of from about 1:1 to about 2:1 is beneficially employed in the present invention. More
5 preferably, a molar ratio of activated oxidizing compound to nitric oxide of about 1:1 is employed.

Solvents for use in the oxidizing solution include any inert carrier capable of dissolving the oxidizing compound that is suitable for exposure to microwave energy and that can be later emitted to the atmosphere. In
10 particular, water can be advantageously employed as the oxidizing solution solvent. In one beneficial aspect of that embodiment, the oxidizing solution pumping system **36** pumps an aqueous hydrogen peroxide solution having a concentration of between 5% and 70% from the oxidation solution reservoir **38**
15 through the oxidation solution supply line **40** and the oxidation solution injection line **42** to a distributor such as a nebulizer **22**. In an alternative embodiment, pure oxidizing compound is introduced into the oxidation chamber by a distributor.

As shown in Figures 1 - 6, a microwave generator **24** is positioned so as to emit electromagnetic energy into the oxidation chamber **18**. Microwave
20 energy is generally defined as electromagnetic radiation having frequencies between 300 to 300,000 MHz. Four frequencies were established by the Federal Communications Commission for use in industrial and scientific microwave heating and drying: 915, 2450, 5800, and 22,125 MHz. As an
25 example, the microwave frequency most often employed in microwave ovens is 2450 MHz, commonly with an energy output of 600 to 700 Watts. The microwave radiation provided in the present invention is in an amount sufficient to activate the oxidizing compound. In one aspect of the present invention, a microwave generator **24** operating at 2450 MHz and rated at 800
30 Watts is employed.

The microwave generator **24** irradiates the oxidation chamber **18** through an opening defined in the wall of the oxidation chamber **18**. In one embodiment, the opening defines a rectangular shape. The microwave generator **24** can be mounted on the surface of the oxidation chamber **18** directly over the opening. The microwave generator **24** can be mounted flush

to or optionally protrude through the opening defined in the oxidation chamber 18. The corrosion shield 20 covers the exposed surface of the microwave generator 24 thus protecting the microwave generator from attack by the oxidizing compound.

5 In general, microwave energy is generated by means such as a magnetron as is well known in the art. The magnetron typically emits microwave energy from an antenna enclosed in a vacuum tube. In the present invention, the microwave generator 24 provides microwave energy through an antenna or antenna array, thus producing a microwave energy zone 43, defined
10 by the area between broken lines 44, within the oxidation chamber 18. The microwave energy zone 43 is preferably located so as to maximize the energy applied to the oxidizing solution. In particular, when a wicking system is used the microwave energy zone 43 is positioned such that the oxidizing solution in the upper end of the wicks 32 is irradiated. Further, the microwave energy
15 zone 43 is preferably positioned such that the flow of the gas stream 10 passes through the microwave energy zone 43, thereby exposing the gas stream to the activated oxidation compound. In a further embodiment, baffles 28 are used to enhance contact between the activated oxidizing compound and the gas stream 10 by inducing turbulence. In one aspect of the invention, the microwave
20 energy introduced into the chamber is in an amount such that the energy is completely absorbed thus protecting the magnetron by minimizing the microwave energy reflected back to the microwave generator 24. Also, in one aspect of the invention a mode stirrer can be employed within the microwave generator 24 thus promoting a more even distribution of the
25 microwaves within the microwave energy zone 43.

The electromagnetic energy present in the microwave energy zone 43 activates the oxidation compound. A sufficient amount of microwave radiation is emitted into the oxidation chamber 18 to activate the oxidizing compound. The result of this activation is threefold. First, vaporization of the oxidation
30 compound occurs. Second, the temperature of the oxidation compound is elevated. For example, when hydrogen peroxide is used, the temperature is elevated from ambient up to just below or at the boiling point of hydrogen peroxide, which is 152 °C under standard conditions. Third, the microwave energy results in the formation of highly reactive and short lived free radical

forms of the oxidizing compound. In particular, hydrogen peroxide forms two free radicals, OH• and HOO•.

The various forms of activated oxidizing compound react with the nitric oxide present in the gas stream **10** oxidizing the NO to NO₂ or other higher valence nitrogen oxides. The dwell time in the oxidation chamber **18** is typically fairly short. For example, the oxidizing solution can be irradiated for a period of time ranging from about .01 to about 5 seconds, preferably for about .05 to about 3 seconds.

In one advantageous embodiment, activated hydrogen peroxide reacts with the nitric oxide present in the gas stream **10**. In a further beneficial aspect of the invention, at least about 80%, and preferably at least about 99%, of the nitric oxide present in the gas stream **10** is oxidized into higher valence nitrogen oxides. Further, the inclusion of methanol in the oxidizing solution can be beneficial in the conversion of certain lower valence compounds such as SO₃, CO and volatile organic compounds present in the gas stream to more readily scrubable or innocuous compounds, such as SO₂, CO₂, and the like, as taught in U.S. Patent No. 5,670,122.

The microwave generator **24** and the oxidizing solution pumping system **36** are both mounted on the outside surface of the oxidation chamber **18**. Their position in relation to each other is not critical except to provide clearance for access and other components. For example, the microwave generator **24** can be oriented at an angle of between 45-180° with respect to an axis **A** perpendicular to the flue **12** as shown in Figure 1. In the advantageous embodiment depicted in Figure 1, the microwave generator is at an angle of 180° with reference to the oxidizing solution pumping system **36**.

The effluent gas oxidation system of the present invention can be operated as a continuous or batch process. In one aspect of the invention, the microwave generator **24** is operated continuously. The power level of the microwave generator that is selected typically depends on the ambient temperature of the gas, the gas stream flow rate and the cross-sectional area of the flue **12**. In particular, the power level is typically set at lower levels for higher gas ambient temperatures and higher levels for higher gas flow rates and flue cross-sectional areas. The rate of oxidizing compound or solution delivery from the distributor is preferably sufficient to oxidize substantially all of the

nitric oxide in the gas stream without using excess oxidizing compound. As will be understood by those skilled in the art, the rate of delivery will depend on the gas flow rate and temperature, and the nitric oxide content in the gas stream.

5 In one embodiment of the present invention, the rate at which the oxidizing compound or solution is delivered by the distributor is controlled using a closed loop system as shown in Figure 6. In this embodiment, a sensor **46** is used to monitor the amount of nitric oxide exiting the oxidation chamber **18**. The sensor **46** provides data to a controller **48** that regulates the oxidation
10 solution pumping system **36**. Based on the controller **48** output, oxidation solution pumping system **36** provides the distributor with the amount of oxidizing compound required to minimize residual nitric oxide in the oxidized gas stream **50**. The oxidizing compound can be introduced into the oxidation chamber **18** on either a continuous or intermittent basis. Further, in an
15 alternative embodiment, a closed loop controller regulates whether the microwave generator is on or off or can otherwise regulate the microwave energy emitted into the oxidation chamber **18**. In yet another aspect of the invention, a closed loop system controls both the oxidation solution pumping system **36** and the microwave generator **24**.

20 As illustrated in Figure 1, after exiting the effluent gas oxidation system **14**, the oxidized gas stream **50** is subjected to an absorption process to remove the higher valence nitrogen oxide compounds, e.g. nitrogen dioxide, from the gas stream prior to emitting the scrubbed gas stream **52** to the atmosphere. In particular, the oxidized gas stream **50** can be passed through a wet scrubber **16**
25 and treated therein with a scrubber medium. The wet scrubber **16** can be a conventional scrubber such as those installed on utility boilers. Advantageously, the wet scrubber **16** is of the type commonly used by power plants for sulfur dioxide scrubbing. In general, a wet scrubber employing an absorbing solution of water and an alkali in the form of nitrates is known in the
30 art for use in the absorption of higher valence nitrogen oxides.

The present invention will be further illustrated by the following non-limiting example.

EXAMPLE

A self-supporting gas oxidation apparatus was provided that included of a calibrated gas supply, an oxidation chamber, a microwave generator, a distributor, and a nitric oxide monitor. The oxidation chamber, roughly rectangular in shape, was 6 inches tall by 4 inches deep by 4 inches wide. The microwave generator supplied approximately 650 W of energy to the oxidation chamber on a continuous basis. To simulate the use of a wicking system distributor, a cylindrical glass vessel containing an oxidizing solution was placed in the microwave energy zone of the oxidation chamber. The oxidizing solution was 200 ml of an aqueous solution of hydrogen peroxide at a concentration of 50%.

The gas stream employed was a standard automotive emissions tester's calibration gas having a nitric oxide concentration entering the oxidation chamber of 2084 ppm. The gas stream flowed continuously through the oxidation chamber at a constant rate of 0.65 liters per minute. After exiting the oxidation chamber, the oxidized gas stream passed through two 300 ml water traps before entering an emissions analyzer. An emissions analyzer was used to monitor the nitric oxide present in the oxidized gas stream in ppm.

After an initially purging the oxidation chamber with the calibration gas, the microwave generator was turned on. A series of tests were performed. In one study, a constant 0.65 liter/min flow of calibration gas was subjected to microwave radiation within the oxidation chamber, and residual nitric oxide concentrations in the oxidized gas was determined over a prolonged length of time. In this study, an initial reading of 1200 ppm nitric oxide was noted at 6 minutes into the test, dropping to 25 ppm at 13 minutes, 6 ppm at 18 min and 4 ppm at 21.5 minutes. The initial time period of the study was used to raise the temperature of the oxidizing solution from ambient to vaporization temperature. Numerous additional tests exploring the stability and range of operation of the system showed residual nitric oxide concentrations down into the range of 4 to 10 ppm consistently.

Many modifications and other embodiments of the invention will come to mind to one skilled in the art to which this invention pertains having the benefit of the teachings presented in the foregoing descriptions and the associated drawings. Therefore, it is to be understood that the invention is not to be limited to the specific embodiments disclosed and that modifications and

other embodiments are intended to be included within the scope of the appended claims. Although specific terms are employed herein, they are used in a generic and descriptive sense only and not for purposes of limitation.

THAT WHICH IS CLAIMED:

1. A method for oxidizing nitric oxide (NO) in a gaseous stream comprising:
 - (a) providing a gaseous stream comprising nitric oxide;
 - (b) introducing at least one oxidizing compound into said
5 gaseous stream;
 - (c) irradiating said oxidizing compound in said gaseous stream with microwave energy in an amount sufficient to activate said oxidizing compound; and
 - (d) contacting the nitric oxide with said activated oxidizing
10 compound to oxidize the nitric oxide into a higher valence nitrogen oxide.
2. A method of Claim 1, wherein said providing step comprises providing a gaseous stream that further includes SO₃, a volatile organic compound, or a mixture thereof, said method further comprising the step of
15 converting the SO₃ and volatile organic compound to more desirable compounds.
3. A method of Claim 1, wherein said oxidizing compound is dissolved in an oxidizing solution, said oxidizing solution further comprising a solvent.
4. A method of Claim 1, wherein said oxidizing compound is hydrogen peroxide.
5. A method of Claim 1, wherein said introducing step further comprises atomizing said oxidizing compound.
- 20 6. A method of Claim 1, wherein said introducing step comprises vaporizing said oxidizing compound.
7. A method of Claim 1, further comprising the steps of
 - (a) monitoring said gaseous stream following said
contacting step to detect residual nitric oxide; and

(b) controlling the quantity of oxidizing compound in said introducing step so as to minimize said nitric oxide present in said gaseous stream.

8. A method of Claim 1, further comprising the steps of

(a) monitoring said gaseous stream following said
5 contacting step to detect residual nitric oxide; and

(b) controlling the microwave energy in said irradiating step.

9. A method of Claim 1, wherein said gaseous stream is a effluent stream from a combustion process.

10. An apparatus for oxidizing a nitric oxide-containing gaseous stream comprising:

(a) an oxidation chamber for contacting a nitric oxide-containing gaseous stream with an activated oxidizing compound;

(b) at least one distributor to introduce said oxidizing compound into said oxidation chamber, said distributor supplying said oxidizing
15 compound through a first opening defined in said oxidation chamber;

(c) at least one microwave generator for irradiating said oxidizing compound and thereby forming said activated oxidizing compound, said microwave generator emitting microwave energy through a second opening defined in said oxidation chamber; and

(d) a corrosion shield lining interior surfaces of said oxidation
20 chamber and covering exposed portions of said microwave generator in said second opening of said oxidation chamber.

11. An apparatus of Claim 10, further comprising baffles attached to
25 said corrosion shield to promote mixing of said activated oxidizing compound and said nitric oxide-containing gaseous stream.

12. An apparatus of Claim 10, wherein said oxidation chamber further comprises a metallic cylindrical member having an inlet for allowing said gas stream to enter said chamber and an outlet for allowing said gas stream to exit said chamber after irradiation.
- 5 13. An apparatus of Claim 12, wherein said inlet and said outlet further comprise flanges to secure said oxidation chamber in a flue.
14. An apparatus of Claim 10, wherein said oxidizing compound is hydrogen peroxide.
- 10 15. An apparatus of Claim 10, wherein said distributor comprises a nebulizer.
16. An apparatus of Claim 10, wherein said distributor comprises a wicking system.
17. An apparatus of Claim 10, wherein said distributor comprises a nebulizer in conjunction with a wicking system.
- 15 18. An apparatus of Claim 10, further comprising a closed loop control system for monitoring the amount of nitric oxide present in the gas stream exiting said oxidation chamber and controlling the amount of oxidizing compound provided by the distributor.
19. An effluent gas emission system, comprising the apparatus of Claim 10 and a wet scrubber for scrubbing the gaseous stream exiting said apparatus.
- 20 20. An effluent gas emission system, comprising the apparatus of Claim 10 and a combustion chamber for producing a nitric oxide-containing effluent gas stream that is fed to the apparatus.

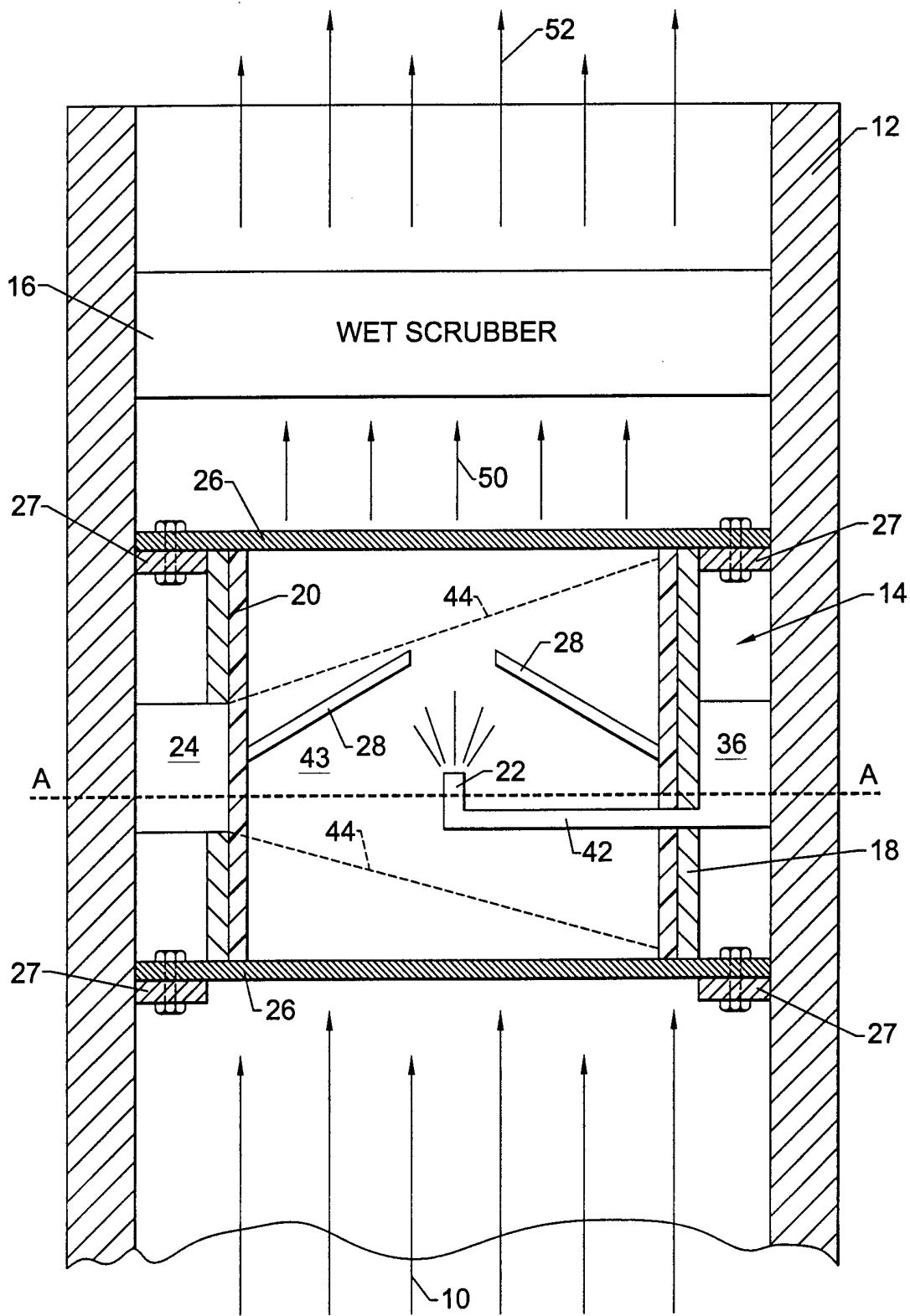

FIG. 1.

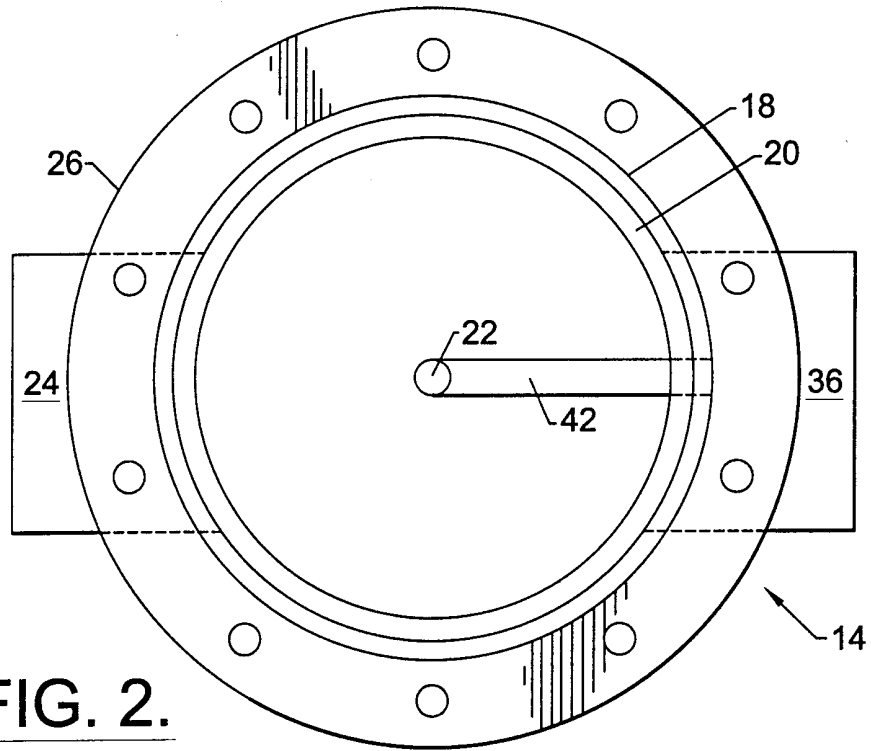

FIG. 2.

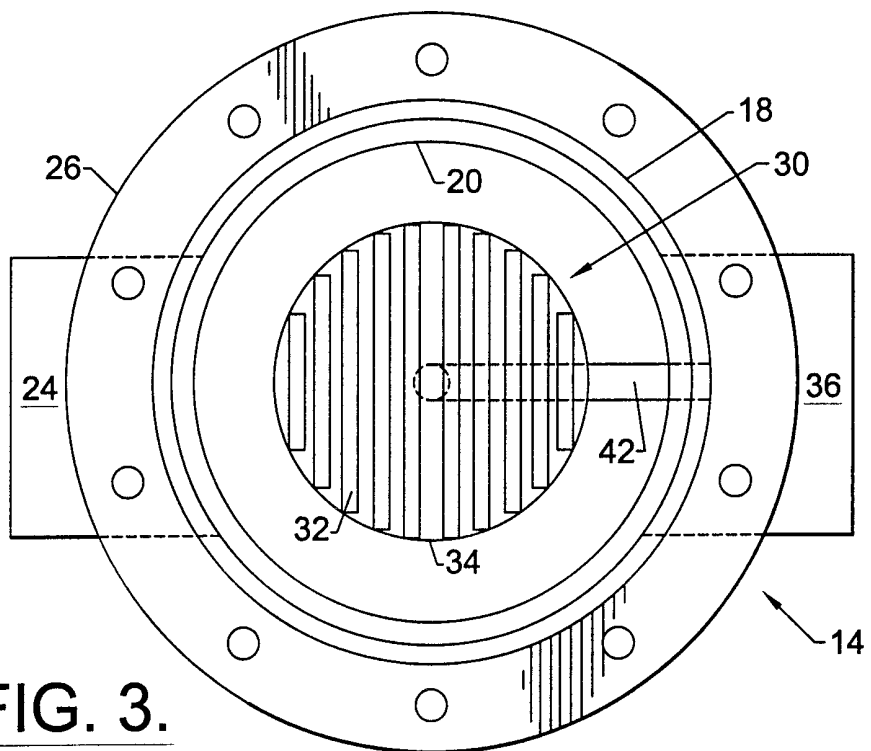

FIG. 3.

3/4

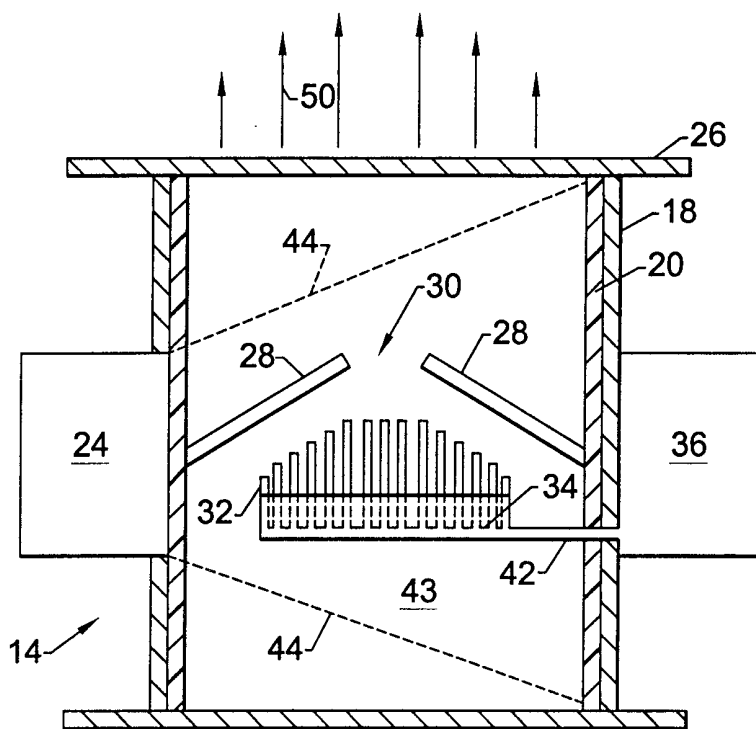

FIG. 4.

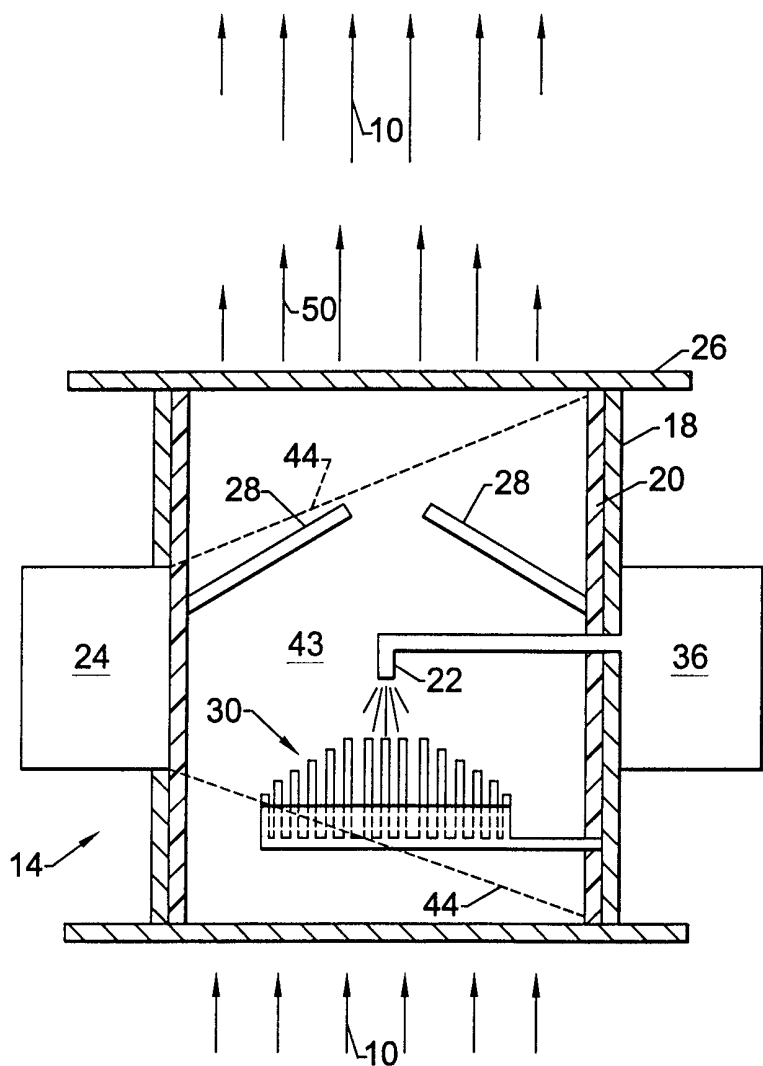

FIG. 5.

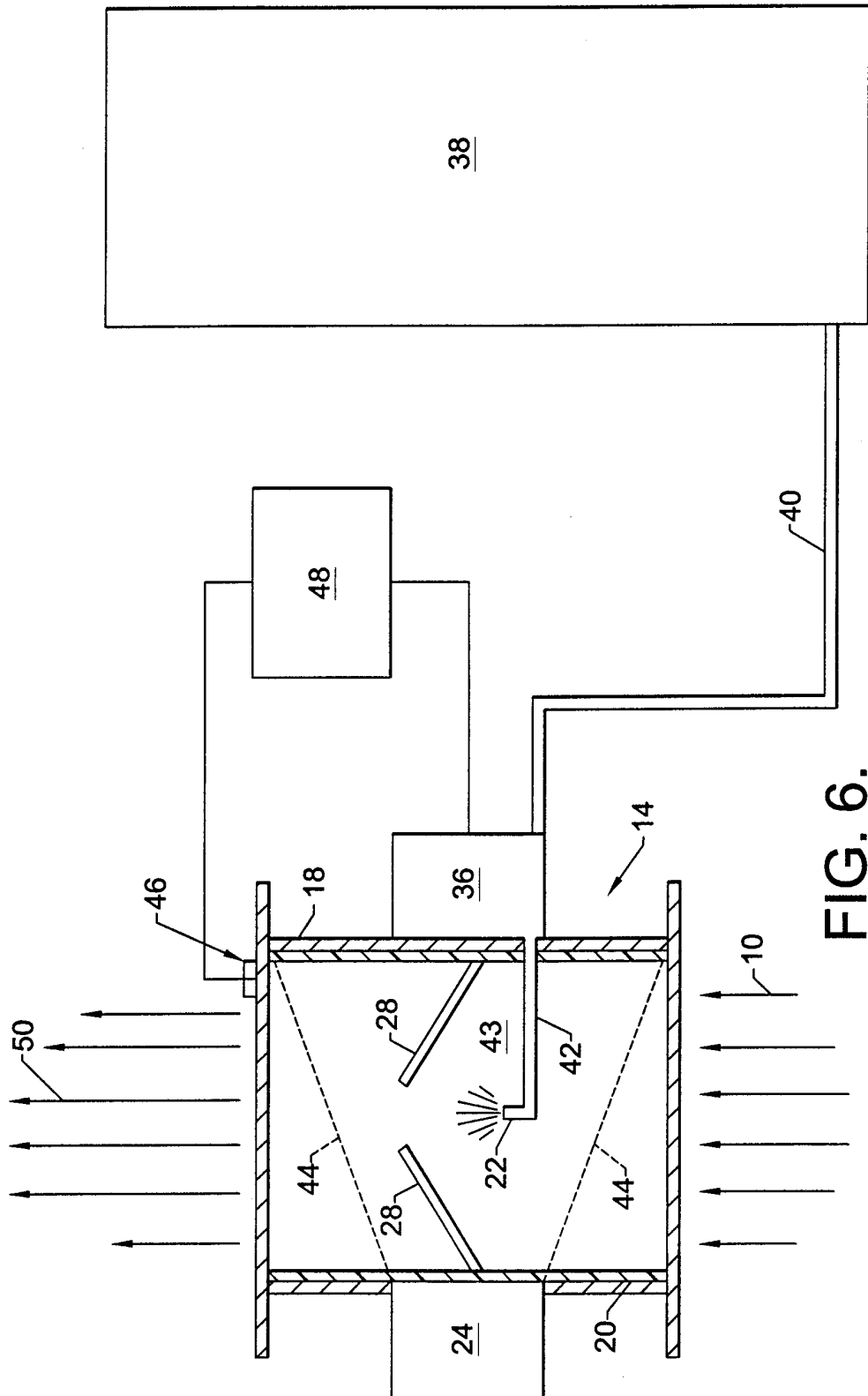

FIG. 6.

INTERNATIONAL SEARCH REPORT

I. International Application No PCT/US 00/01589

A. CLASSIFICATION OF SUBJECT MATTER

IPC 7 B01D53/56 B01D53/60 B01D53/32 B01J19/12 B01D53/92
 F01N3/01

According to International Patent Classification (IPC) or to both national classification and IPC

B. FIELDS SEARCHED

Minimum documentation searched (classification system followed by classification symbols)

IPC 7 B01D B01J

Documentation searched other than minimum documentation to the extent that such documents are included in the fields searched

Electronic data base consulted during the international search (name of data base and, where practical, search terms used)

EPO-Internal WPI PAJ

C. DOCUMENTS CONSIDERED TO BE RELEVANT

Category *	Citation of document, with indication, where appropriate, of the relevant passages	Relevant to claim No.
X	US 5 397 444 A (ZIMEK ET AL) 14 March 1995 (1995-03-14) column 1, line 35 -column 1, line 56 column 2, line 35 -column 6, line 7 ---	1-9
X	EP 0 295 083 A (EFTHIMION ET AL) 14 December 1988 (1988-12-14) page 4, line 40 -page 7, line 34 page 14, line 12 -page 14, line 45 ---	1,4,9, 10,12, 13,15-18
X	EP 0 680 243 A (VARIAN ASSOCIATES, INC.) 2 November 1995 (1995-11-02)	10,12, 13,15-18
Y	column 4, line 15 -column 7, line 16 --- -/--	19

Further documents are listed in the continuation of box C.

Patent family members are listed in annex.

* Special categories of cited documents :

- *A* document defining the general state of the art which is not considered to be of particular relevance
- *E* earlier document but published on or after the international filing date
- *L* document which may throw doubts on priority claim(s) or which is cited to establish the publication date of another citation or other special reason (as specified)
- *O* document referring to an oral disclosure, use, exhibition or other means
- *P* document published prior to the international filing date but later than the priority date claimed

- *T* later document published after the international filing date or priority date and not in conflict with the application but cited to understand the principle or theory underlying the invention
- *X* document of particular relevance; the claimed invention cannot be considered novel or cannot be considered to involve an inventive step when the document is taken alone
- *Y* document of particular relevance; the claimed invention cannot be considered to involve an inventive step when the document is combined with one or more other such documents, such combination being obvious to a person skilled in the art.
- *Z* document member of the same patent family

Date of the actual completion of the international search

25 May 2000

Date of mailing of the international search report

06/06/2000

Name and mailing address of the ISA

European Patent Office, P.B. 5818 Patentlaan 2
 NL - 2280 HV Rijswijk
 Tel. (+31-70) 340-2040, Tx. 31 651 epo nl,
 Fax: (+31-70) 340-3016

Authorized officer

Doolan, G

INTERNATIONAL SEARCH REPORT

International Application No

PCT/US 00/01589

C.(Continuation) DOCUMENTS CONSIDERED TO BE RELEVANT		
Category °	Citation of document, with indication, where appropriate, of the relevant passages	Relevant to claim No.
X	WO 98 11982 A (THERMO POWER CORPORATION) 26 March 1998 (1998-03-26) page 8, line 9 -page 13, line 1 page 34, line 6 -page 36, line 6; example 12 ---	1, 3-9
Y	WO 98 30312 A (HUOVILAINEN) 16 July 1998 (1998-07-16) page 4, line 21 -page 5, line 21 ---	19
Y	US 5 670 122 A (ZAMANSKY ET AL) 23 September 1997 (1997-09-23) column 2, line 3 -column 2, line 12 column 4, line 45 -column 11, line 48 ---	19
A	EP 0 845 287 A (AEA TECHNOLOGY PLC) 3 June 1998 (1998-06-03) page 2, line 49 -page 4, line 23 ---	1, 4, 5
A	EP 0 845 287 A (AEA TECHNOLOGY PLC) 3 June 1998 (1998-06-03) page 2, line 49 -page 4, line 23 ---	10, 12
A	US 5 811 631 A (CRIPE ET AL) 22 September 1998 (1998-09-22) column 2, line 64 -column 5, line 46 -----	10, 12

INTERNATIONAL SEARCH REPORT

Information on patent family members

International Application No

PCT/US 00/01589

Patent document cited in search report	Publication date	Patent family member(s)	Publication date
US 5397444 A	14-03-1995	PL 165767 B	28-02-1995
		PL 165728 B	28-02-1995
		AT 146986 T	15-01-1997
		CA 2087833 A	22-11-1992
		CN 1067724 A	06-01-1993
		DE 69216367 D	13-02-1997
		DE 69216367 T	24-04-1997
		DK 540756 T	24-03-1997
		EP 0540756 A	12-05-1993
		ES 2102501 T	01-08-1997
		GR 3023008 T	30-07-1997
		WO 9220433 A	26-11-1992
		JP 6501202 T	10-02-1994
		PL 297650 A	18-04-1994
RU 2113889 C	27-06-1998		
EP 295083 A	14-12-1988	US 4883570 A	28-11-1989
EP 680243 A	02-11-1995	US 5532462 A	02-07-1996
		AU 1639195 A	16-11-1995
		BR 9501821 A	21-11-1995
		CA 2148010 A,C	30-10-1995
		JP 8083681 A	26-03-1996
WO 9811982 A	26-03-1998	US 6030506 A	29-02-2000
		AU 4484897 A	14-04-1998
WO 9830312 A	16-07-1998	FI 953113 A	22-12-1996
		AU 1197097 A	03-08-1998
US 5670122 A	23-09-1997	NONE	
EP 845287 A	03-06-1998	GB 2324196 A	14-10-1998
		GB 2319941 A	03-06-1998
		JP 10156176 A	16-06-1998
US 5811631 A	22-09-1998	NONE	