



- (51) International Patent Classification:
H05K 9/00 (2006.01)
- (21) International Application Number:
PCT/US2016/030662
- (22) International Filing Date:
4 May 2016 (04.05.2016)
- (25) Filing Language: English
- (26) Publication Language: English
- (30) Priority Data:
62/159,192 8 May 2015 (08.05.2015) US
- (71) Applicant: LAIRD TECHNOLOGIES, INC. [US/US];
3481 Rider Trail South, Earth City, Missouri 63045 (US).
- (72) Inventors: CHAO, Kuo Chun; 3481 Rider Trail South,
Earth City, Missouri 63045 (US). LIN, Yi-Shen; 3481
Rider Trail South, Earth City, Missouri 63045 (US).
YUEH, Liu Ming; 3481 Rider Trail South, Earth City,
Missouri 63045 (US).
- (74) Agent: FUSSNER, Anthony G.; 7700 Bonhomme, Suite
400, St. Louis, Missouri 63105 (US).

- (81) Designated States (unless otherwise indicated, for every kind of national protection available): AE, AG, AL, AM, AO, AT, AU, AZ, BA, BB, BG, BH, BN, BR, BW, BY, BZ, CA, CH, CL, CN, CO, CR, CU, CZ, DE, DK, DM, DO, DZ, EC, EE, EG, ES, FI, GB, GD, GE, GH, GM, GT, HN, HR, HU, ID, IL, IN, IR, IS, JP, KE, KG, KN, KP, KR, KZ, LA, LC, LK, LR, LS, LU, LY, MA, MD, ME, MG, MK, MN, MW, MX, MY, MZ, NA, NG, NI, NO, NZ, OM, PA, PE, PG, PH, PL, PT, QA, RO, RS, RU, RW, SA, SC, SD, SE, SG, SK, SL, SM, ST, SV, SY, TH, TJ, TM, TN, TR, TT, TZ, UA, UG, US, UZ, VC, VN, ZA, ZM, ZW.
- (84) Designated States (unless otherwise indicated, for every kind of regional protection available): ARIPO (BW, GH, GM, KE, LR, LS, MW, MZ, NA, RW, SD, SL, ST, SZ, TZ, UG, ZM, ZW), Eurasian (AM, AZ, BY, KG, KZ, RU, TJ, TM), European (AL, AT, BE, BG, CH, CY, CZ, DE, DK, EE, ES, FI, FR, GB, GR, HR, HU, IE, IS, IT, LT, LU, LV, MC, MK, MT, NL, NO, PL, PT, RO, RS, SE, SI, SK, SM, TR), OAPI (BF, BJ, CF, CG, CI, CM, GA, GN, GQ, GW, KM, ML, MR, NE, SN, TD, TG).

Published:
— with international search report (Art. 21(3))

(54) Title: ELECTROMAGNETIC INTERFERENCE (EMI) SHIELDS INCLUDING FORM-IN-PLACE AND/OR 3D PRINTED WALLS

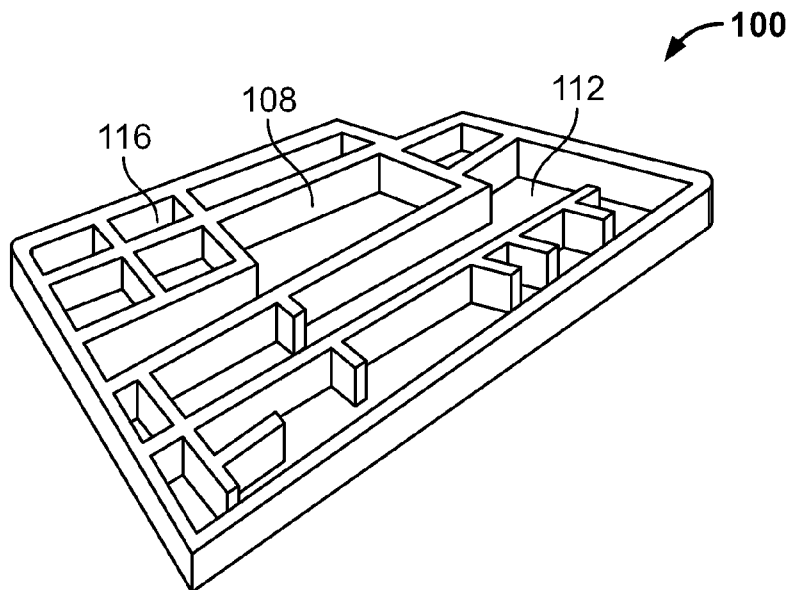

FIG. 1

(57) Abstract: According to various aspects, exemplary embodiments are disclosed of EMI shields, shielding assemblies, and related methods. In an exemplary embodiment, a shielding assembly generally includes one or more soft and/or flexible walls dispensed and formed on a substrate. Also disclosed are exemplary methods relating to providing shielding for one or more components on a substrate. In an exemplary embodiment, a method generally includes 3D printing material and/or dispensing a form-in-place material onto a substrate to thereby form one or more walls on the substrate that are disposed generally about the one or more components.

ELECTROMAGNETIC INTERFERENCE (EMI) SHIELDS INCLUDING FORM-IN-PLACE AND/OR 3D PRINTED WALLS

CROSS-REFERENCE TO RELATED APPLICATION

[0001] This application is a PCT International Application of U.S. Provisional Patent Application No. 62/159,192 filed May 8, 2015. The entire disclosure of the above application is incorporated herein by reference.

FIELD

[0002] The present disclosure generally relates to EMI shields including form-in-place and/or 3D printed walls and related methods.

BACKGROUND

[0003] This section provides background information related to the present disclosure which is not necessarily prior art.

[0004] A common problem in the operation of electronic devices is the generation of electromagnetic radiation within the electronic circuitry of the equipment. Such radiation may result in electromagnetic interference (EMI) or radio frequency interference (RFI), which can interfere with the operation of other electronic devices within a certain proximity. Without adequate shielding, EMI/RFI interference may cause degradation or complete loss of important signals, thereby rendering the electronic equipment inefficient or inoperable.

[0005] A common solution to ameliorate the effects of EMI/RFI is through the use of shields capable of absorbing and/or reflecting and/or redirecting EMI energy. These shields are typically employed to localize EMI/RFI within its source, and to insulate other devices proximal to the EMI/RFI source.

[0006] The term “EMI” as used herein should be considered to generally include and refer to EMI emissions and RFI emissions, and the term “electromagnetic” should be considered to generally include and refer to electromagnetic and radio frequency from external sources and internal sources. Accordingly, the term shielding (as used herein) broadly includes and refers to mitigating (or limiting) EMI and/or RFI, such as by absorbing, reflecting, blocking, and/or

redirecting the energy or some combination thereof so that it no longer interferes, for example, for government compliance and/or for internal functionality of the electronic component system.

SUMMARY

[0007] This section provides a general summary of the disclosure, and is not a comprehensive disclosure of its full scope or all of its features.

[0008] According to various aspects, exemplary embodiments are disclosed of EMI shields, shielding assemblies, and related methods. In an exemplary embodiment, a shielding assembly generally includes one or more soft and/or flexible walls dispensed and formed on a substrate. Also disclosed are exemplary methods relating to providing shielding for one or more components on a substrate. In an exemplary embodiment, a method generally includes 3D printing material and/or dispensing a form-in-place material onto a substrate to thereby form one or more walls on the substrate that are disposed generally about the one or more components.

[0009] Further areas of applicability will become apparent from the description provided herein. The description and specific examples in this summary are intended for purposes of illustration only and are not intended to limit the scope of the present disclosure.

DRAWINGS

[0010] The drawings described herein are for illustrative purposes only of selected embodiments and not all possible implementations, and are not intended to limit the scope of the present disclosure.

[0011] FIG. 1 is a perspective view of an EMI shield according to an exemplary embodiment;

[0012] FIG. 2 is a perspective view of an EMI shield cover according to an exemplary embodiment;

[0013] FIG. 3 is a perspective view of a form-in-place process of dispensing shielding material according to an exemplary embodiment; and

[0014] FIG. 4 is a perspective view of a 3D printing process of dispensing shielding material according to an exemplary embodiment.

DETAILED DESCRIPTION

[0015] Example embodiments will now be described more fully with reference to the accompanying drawings.

[0016] Disclosed herein are exemplary embodiments of electromagnetic (EMI) shields, shielding apparatus or assemblies that include one or more form-in-place and/or 3D printed portions. For example, exemplary embodiments may include one or more sidewalls, internal walls, fences, frames, *etc.* (hereinafter referred to generally as walls) that are made of soft and/or flexible material that is formed in place and/or 3D printed onto a substrate, *etc.* Some embodiments may also include a cover, top, lid, upper surface, *etc.* (hereinafter referred to generally as a cover).

[0017] In an exemplary embodiment, an EMI shield includes one or more soft and/or flexible form-in-place (FIP) walls. Additionally or alternatively, an EMI shield may include one or more soft and/or flexible walls produced by 3D printing. Materials from which soft and/or flexible walls may be made include, but are not necessarily limited to, silicone, elastomer materials, plastic materials, electrically-conductive fillers (*e.g.*, silver, nickel, copper, graphite, aluminum, *etc.*), combinations thereof, *etc.* A cover may include materials such as metal foil, tin-containing polyimide (PI) film, other EMI shielding film, electrically-conductive fabric (*e.g.*, metal plated cloth, *etc.*), *etc.* In some exemplary embodiments, the cover may be made from a solderable film (*e.g.*, tin/copper-plated polyimide film, other metal plated films, other solderable electrically-conductive films, *etc.*). In some embodiments, a substrate upon which walls are dispensed may serve as a cover when the walls are installed onto a second substrate, *e.g.*, onto a printed circuit board (PCB), *etc.*

[0018] With reference to the figures, FIG. 1 illustrates an exemplary embodiment of an EMI shielding assembly or apparatus 100 according to aspects of the present disclosure. The EMI shielding assembly 100 includes walls 108 extending from (*e.g.*, attached to, integrally connected with, installed on, *etc.*) a substrate 112. The substrate 112 may be, *e.g.*, a printed circuit board (PCB) or other structure. Additionally or alternatively, the substrate 112 may be or include an electrically-conductive fabric and/or other material(s).

[0019] In an example embodiment in which the substrate 112 is a PCB, the shielding assembly 100 is configured for shielding one or more components that may be provided on the PCB substrate 112 within one or more interior or shielding enclosures cooperatively defined by

the walls 108. Components on the PCB substrate 112 may be positioned in different compartments such that the components are provided with EMI shielding by virtue of the EMI shielding compartments 116 inhibiting the ingress and/or egress of EMI into and/or out of each EMI shielding compartment 116. In other exemplary embodiments, the EMI shield may not include or may be free of interior walls, dividers, or partitions such that the sidewalls and cover of the EMI shield generally define a single interior space or compartment.

[0020] In some example embodiments, walls may be made from a form-in-place (FIP) material, such as silver/nickel filled silicone elastomer form-in-place material, nickel/graphite filled silicone elastomer form-in-place material, silver/aluminum filled silicone elastomer form-in-place material, silver/copper filled silicone elastomer form-in-place material, *etc.* In an exemplary embodiment, the walls are made of silver/nickel filled silicone elastomer form-in-place (FIP) material. In this example, the silver/nickel filled silicone elastomer FIP walls have the following physical properties: Shore A (ASTM D2240) hardness of about 60, a tensile elongation (ASTM D412) of about 110%, a tensile strength (ASTM D412) of about 192 pounds per square inch (psi), a compression set (ASTM D395) of about 15%, a compression deflection (with a bead size of about 0.62 mm height and about 0.7 mm width) at 20 percent compression of about 1.7 pounds per inch and at 40 percent compression of about 6.4 pounds per inch, an adhesion strength (AI) of about 180 Newtons per centimeter squared (N/cm²), an operating temperature range from about -50 degrees Celsius to about 125 degrees Celsius, and a UL rating of V0. Continuing with this example, the silver/nickel filled silicone elastomer FIP walls have a volume resistivity of about 0.005 ohm-centimeters and a shielding effectiveness of greater than 100 decibels (dB) for frequencies between 200 Megahertz (MHz) and 10 Gigahertz (GHz). The curing conditions for the silver/nickel filled silicone elastomer FIP walls were 15 degrees Celsius to 40 degrees Celsius at 50% relative humidity. At 22 degrees Celsius and 50% relative humidity, the time before handling was about 1 hour and the time to a full or complete cure was about 24 hours. Alternative embodiments may be configured differently, such that the FIP walls have different physical properties, electrical properties, and/or curing conditions than described above.

[0021] In another exemplary embodiment, the walls are made of nickel/graphite filled silicone elastomer form-in-place (FIP) material. In this example, the nickel/graphite filled silicone elastomer FIP walls have the following physical properties: Shore A (ASTM D2240)

hardness of about 70, a compression set (ASTM D395) of about 15%, a compression deflection (with a bead size of about 0.6 mm height and about 0.7 mm width) at 20 percent compression of about 3.2 pounds per inch and at 40 percent compression of about 11.5 pounds per inch, an adhesion strength (Al) of greater than about 180 Newtons per centimeter squared (N/cm^2), an operating temperature range from about -50 degrees Celsius to about 150 degrees Celsius, and a UL rating of V0. Continuing with this example, the nickel/graphite filled silicone elastomer FIP walls have a volume resistivity of about 0.030 ohm-centimeters and a shielding effectiveness of greater than 90 decibels (dB) for frequencies between 200 Megahertz (MHz) and 10 Gigahertz (GHz). The curing conditions for the nickel/graphite filled silicone elastomer FIP walls were a minimum temperature of 120 degrees Celsius and a 1 hour cure time at 125 degrees Celsius. Alternative embodiments may be configured differently, such that the FIP walls have different physical properties, electrical properties, and/or curing conditions than described above.

[0022] In another example embodiment, the walls are made of silver/nickel filled silicone elastomer FIP material have the following physical properties: Shore A (ASTM D2240) hardness of about 65, a compression set (ASTM D395) of about 10%, an adhesion strength (Al) of about 200 Newtons per centimeter squared (N/cm^2), an operating temperature range from about -50 degrees Celsius to about 125 degrees Celsius, and a UL rating of V0. Continuing with this example, the silver/nickel filled silicone elastomer FIP walls have a volume resistivity of about 0.005 ohm-centimeters and a shielding effectiveness of greater than 100 decibels (dB) for frequencies between 200 Megahertz (MHz) and 10 Gigahertz (GHz). The curing conditions for the silver/nickel filled silicone elastomer FIP walls were a minimum temperature of 120 degrees Celsius and a 1.5 hour cure time at 125 degrees Celsius. Alternative embodiments may be configured differently, such that the FIP walls have different physical properties, electrical properties, and/or curing conditions than described above.

[0023] In an additional exemplary embodiment, the walls are made of nickel/graphite filled silicone elastomer form-in-place (FIP) material. In this example, the nickel/graphite filled silicone elastomer FIP walls have the following physical properties: Shore A (ASTM D2240) hardness of about 70, a tensile elongation (ASTM D412) of about 50%, a tensile strength (ASTM D412) of about 180 pounds per square inch (psi), a compression set (ASTM D395) of about 15%, a compression deflection (with a bead size of about 0.62 mm height and about 0.7 mm width) at 20 percent compression of about 1.5 pounds per inch and at 40 percent

compression of about 7.9 pounds per inch, an adhesion strength (A1) of about 150 Newtons per centimeter squared (N/cm^2), an operating temperature range from about -50 degrees Celsius to about 125 degrees Celsius, and a UL rating of V0. Continuing with this example, the nickel/graphite filled silicone elastomer FIP walls have a volume resistivity of about 0.030 ohm-centimeters and a shielding effectiveness of greater than 100 decibels (dB) for frequencies between 200 Megahertz (MHz) and 10 Gigahertz (GHz). The curing conditions for the nickel/graphite filled silicone elastomer FIP walls were 15 degrees Celsius to 40 degrees Celsius at 50% relative humidity. At 22 degrees Celsius and 50% relative humidity, the time before handling was about 1 hour and the time to a full or complete cure was about 24 hours. Alternative embodiments may be configured differently, such that the FIP walls have different physical properties, electrical properties, and/or curing conditions than described above.

[0024] In a further exemplary embodiment, the walls are made of silver/aluminum filled silicone elastomer form-in-place (FIP) material. In this example, the silver/aluminum filled silicone elastomer FIP walls have the following physical properties: Shore A (ASTM D2240) hardness of about 70, a tensile strength (ASTM D412) of about 1600 kilopascals (kPa), a tensile elongation (ASTM D412) of about 100%, a compression set (ASTM D395) of about 10%, a compression deflection (with a bead size of about 0.6 mm height and about 0.7 mm width) at 20 percent compression of about 2.3 pounds per inch and at 40 percent compression of about 10.5 pounds per inch, an adhesion strength (A1) of about 200 Newtons per centimeter squared (N/cm^2), an operating temperature range from about -50 degrees Celsius to about 125 degrees Celsius, and a UL rating of V0. Continuing with this example, the silver/aluminum filled silicone elastomer FIP walls have a volume resistivity of about 0.005 ohm-centimeters and a shielding effectiveness of greater than 90 decibels (dB) for frequencies between 200 Megahertz (MHz) and 10 Gigahertz (GHz). The cure conditions for the silver/aluminum filled silicone elastomer FIP walls were a minimum temperature of 120 degrees Celsius and a 1 hour cure time at 125 degrees Celsius. Alternative embodiments may be configured differently, such that the FIP walls have different physical properties, electrical properties, and/or curing conditions than described above.

[0025] In yet another exemplary embodiment, the walls are made of silver/aluminum filled silicone elastomer form-in-place (FIP) material. In this example, the silver/aluminum filled silicone elastomer FIP walls have the following physical properties: Shore A (ASTM D2240) hardness of about 60, a tensile strength (ASTM D412) of about 850 kilopascals (kPa), a tensile

elongation (ASTM D412) of about 140%, a compression set (ASTM D395) of about 10%, a compression deflection (with a bead size of about 0.6 mm height and about 0.75 mm width) at 20 percent compression of about 1.9 pounds per inch and at 40 percent compression of about 8.3 pounds per inch, an adhesion strength (A1) of about 140 Newtons per centimeter squared (N/cm^2), an operating temperature range from about -50 degrees Celsius to about 125 degrees Celsius, and a UL rating of V0. Continuing with this example, the silver/aluminum filled silicone elastomer FIP walls have a volume resistivity of about 0.003 ohm-centimeters and a shielding effectiveness of greater than 90 decibels (dB) for frequencies between 200 Megahertz (MHz) and 10 Gigahertz (GHz). The curing conditions for the silver/aluminum filled silicone elastomer FIP walls were 15 degrees Celsius to 40 degrees Celsius at 50% relative humidity. At 22 degrees Celsius and 50% relative humidity, the time before handling was about 1 hour and the time to a full or complete cure was about 24 hours. Alternative embodiments may be configured differently, such that the FIP walls have different physical properties, electrical properties, and/or curing conditions than described above.

[0026] In still another exemplary embodiment, the walls are made of silver/copper filled silicone elastomer form-in-place (FIP) material. In this example, the silver/copper filled silicone elastomer FIP walls have the following physical properties: Shore A (ASTM D2240) hardness of about 55, a tensile strength (ASTM D412) of about 1300 kilopascals (kPa), a tensile elongation (ASTM D412) of about 300%, a compression set (ASTM D395) of about 10%, a compression deflection (with a bead size of about 0.6 mm height and about 0.7 mm width) at 20 percent compression of about 1.2 pounds per inch and at 40 percent compression of about 5.2 pounds per inch, an adhesion strength (A1) of about 200 Newtons per centimeter squared (N/cm^2), an operating temperature range from about -50 degrees Celsius to about 125 degrees Celsius, and a UL rating of V0. Continuing with this example, the silver/copper filled silicone elastomer FIP walls have a volume resistivity of about 0.002 ohm-centimeters and a shielding effectiveness of greater than 90 decibels (dB) for frequencies between 200 Megahertz (MHz) and 10 Gigahertz (GHz). The curing conditions for the silver/copper filled silicone elastomer FIP walls were 15 degrees Celsius to 40 degrees Celsius at 50% relative humidity. At 22 degrees Celsius and 50% relative humidity, the time before handling was about 1 hour and the time to a full or complete cure was about 24 hours. Alternative embodiments may be configured

differently, such that the FIP walls have different physical properties, electrical properties, and/or curing conditions than described above.

[0027] In some embodiments, wall(s) may be dispensed directly onto a substrate by three-dimensional printing, and one or more form-in-place gaskets may be dispensed onto the top surfaces of the wall(s). In various embodiments, a wall may have a thickness of 0.6 millimeters or less (*e.g.*, 0.5 millimeters, 0.4 millimeters, 0.3 millimeters, less than 0.3 millimeters, *etc.*). In some embodiments, a soft and/or flexible shield may be provided on a soft and/or flexible PCB.

[0028] FIG. 2 shows an example embodiment of a cover 120 that may be attached over the walls 108. The cover 120 may be made of metal foil, electrically-conductive fabric (*e.g.*, metal plated cloth, *etc.*), solderable film, tin-containing polyimide (PI) film (*e.g.*, tin/copper-plated polyimide film, *etc.*), other EMI shielding films, other metal plated films, *etc.* In various embodiments, the cover 120 adheres directly to the walls 108. For example, where the walls 108 are made of material that is sticky or adherent until cured, the wall material itself may be used as an adhesive for attaching the cover to the walls 108. In other embodiments, another or an additional adhesive may be used for attaching the cover to the walls 108.

[0029] In an example embodiment in which the substrate 112 is made of an electrically-conductive fabric and/or other material(s) appropriate for providing a cover, the substrate 112 and attached walls 108 may be turned over and installed as a shield onto a second substrate (not shown), which may be a PCB. In such embodiments, the substrate 112 serves as a cover for the shielding assembly 100.

[0030] Although FIG. 1 illustrates the shielding assembly 100 having a particular shape, other exemplary embodiments may include shields and shielding assemblies having different configurations (*e.g.*, rectangular, circular, curved, triangular, irregular, other non-rectangular shapes, *etc.*). In various embodiments, the external overall height of the shielding assembly 100, cover 120, and walls 108 is less than one millimeter (mm) tall, although other sizes are possible in other embodiments. The dimensions provided in this paragraph and elsewhere in this application are for the purpose of illustration only as other exemplary embodiments may have a different configuration, such as a different size (*e.g.*, larger or smaller) and/or a different shape (*e.g.*, non-rectangular, *etc.*), *etc.*

[0031] Also disclosed are exemplary embodiments of methods relating to making EMI shields and/or shielding assemblies. In an exemplary embodiment, a method generally

includes dispensing a form-in-place and/or 3D printing material onto a substrate to form walls configured to accommodate one or more components on or under the substrate. Form-in-place dispensing is illustrated in FIG. 3, and dispensing by 3D printing is illustrated in FIG. 4. The method includes dispensing the walls using one or more materials such as silicone, elastomer materials, plastic materials, electrically-conductive fillers (*e.g.*, silver, nickel, copper, graphite, aluminum, *etc.*), *etc.* In some embodiments, the method includes dispensing walls on a PCB or other structure serving as a substrate. Such a method also includes configuring the walls to accommodate one or more components on the substrate. After the walls have been dispensed, a cover may be attached directly to and over the walls. Such a method includes, *e.g.*, attaching the cover while the material forming the walls is still curing. In other implementations, another or an additional adhesive may be used to attach the cover to the walls.

[0032] In various embodiments, the method includes dispensing walls on a material that may be used as a cover for a shield. For example, walls may be dispensed onto metal foil, electrically-conductive fabric (*e.g.*, metal plated cloth, *etc.*), solderable film, tin-containing polyimide (PI) film (*e.g.*, tin/copper-plated polyimide film, *etc.*), other EMI shielding films, other metal plated films, *etc.* The method also may include installing the walls and cover onto a second substrate, *e.g.*, a PCB that supports the components under the cover.

[0033] In an exemplary embodiment, a method generally includes dispensing a form-in-place and/or 3D printing material onto a substrate to form walls configured to accommodate one or more components on or under the substrate. For example, a soft and/or flexible electrically-conductive material may be 3D printed directly onto an electrically-conductive fabric to thereby form walls in place on the electrically-conductive fabric. Or, for example, a soft and/or flexible electrically-conductive form-in-place material may be dispensed directly onto an electrically-conductive fabric to thereby form walls in place on the electrically-conductive fabric. In both examples, the electrically-conductive fabric with the form-in-place or 3D printed walls dispensed thereon may be used for providing EMI shielding to one or more components on a PCB or other substrate.

[0034] Exemplary embodiments of methods relating to providing shielding for one or more components on a substrate are also disclosed. In an exemplary embodiment, a method generally includes installing a shield to a substrate such that one or more components are disposed under the shield, where the shield includes one or more soft and/or flexible walls made

of form-in-place material and/or 3D printing material. Installing the shield may include attaching a cover to the walls. In some other embodiments, the shield has a cover from which the walls depend and are configured for installation generally about the components on the substrate.

[0035] In exemplary embodiments, the EMI shield includes a cover, top, or upper surface and one or more walls. The one or more walls may comprise a single wall, may comprise a plurality of walls that are separate or discrete from one other, and/or may comprise a plurality of walls that are connected with one another, *etc.*

[0036] Exemplary embodiments disclosed herein may provide one or more (but not necessarily any or all) of the following advantages over some existing board level EMI shields. For example, exemplary embodiments disclosed herein may be flexible and/or soft compared to conventional shielding made of rigid materials such as metal. Some example embodiments may provide similar or greater component clearance under the shield compared with standard fabricated shields. Example embodiments may weigh less and have lower heights than traditional shielding. Example embodiments may be provided at lower tooling costs compared to the costs of providing conventional board-level shielding. Various implementations make it possible to easily create complex wall configurations having heights less than one millimeter. Depending on materials used, exemplary embodiments of shielding walls disclosed herein may also be waterproof and/or humidity resistant. The processes used to create the EMI shields disclosed herein may provide features and/or allow scale and economy to match high volume electronics manufacturing. Exemplary embodiments may have shielding effectiveness performance about the same as a conventional metal board level shield (BLS). Exemplary embodiments may be able to withstand or pass solder reflow conditions.

[0037] Example embodiments are provided so that this disclosure will be thorough, and will fully convey the scope to those who are skilled in the art. Numerous specific details are set forth such as examples of specific components, devices, and methods, to provide a thorough understanding of embodiments of the present disclosure. It will be apparent to those skilled in the art that specific details need not be employed, that example embodiments may be embodied in many different forms, and that neither should be construed to limit the scope of the disclosure. In some example embodiments, well-known processes, well-known device structures, and well-known technologies are not described in detail. In addition, advantages and improvements that may be achieved with one or more exemplary embodiments of the present disclosure are

provided for purpose of illustration only and do not limit the scope of the present disclosure, as exemplary embodiments disclosed herein may provide all or none of the above mentioned advantages and improvements and still fall within the scope of the present disclosure.

[0038] Specific dimensions, specific materials, and/or specific shapes disclosed herein are example in nature and do not limit the scope of the present disclosure. The disclosure herein of particular values and particular ranges of values for given parameters are not exclusive of other values and ranges of values that may be useful in one or more of the examples disclosed herein. Moreover, it is envisioned that any two particular values for a specific parameter stated herein may define the endpoints of a range of values that may be suitable for the given parameter (*i.e.*, the disclosure of a first value and a second value for a given parameter can be interpreted as disclosing that any value between the first and second values could also be employed for the given parameter). For example, if Parameter X is exemplified herein to have value A and also exemplified to have value Z, it is envisioned that parameter X may have a range of values from about A to about Z. Similarly, it is envisioned that disclosure of two or more ranges of values for a parameter (whether such ranges are nested, overlapping or distinct) subsume all possible combination of ranges for the value that might be claimed using endpoints of the disclosed ranges. For example, if parameter X is exemplified herein to have values in the range of 1 – 10, or 2 – 9, or 3 – 8, it is also envisioned that Parameter X may have other ranges of values including 1 – 9, 1 – 8, 1 – 3, 1 - 2, 2 – 10, 2 – 8, 2 – 3, 3 – 10, and 3 – 9.

[0039] The terminology used herein is for the purpose of describing particular example embodiments only and is not intended to be limiting. As used herein, the singular forms “a”, “an” and “the” may be intended to include the plural forms as well, unless the context clearly indicates otherwise. The terms “comprises,” “comprising,” “including,” and “having,” are inclusive and therefore specify the presence of stated features, integers, steps, operations, elements, and/or components, but do not preclude the presence or addition of one or more other features, integers, steps, operations, elements, components, and/or groups thereof. The method steps, processes, and operations described herein are not to be construed as necessarily requiring their performance in the particular order discussed or illustrated, unless specifically identified as an order of performance. It is also to be understood that additional or alternative steps may be employed.

[0040] When an element or layer is referred to as being “on”, “engaged to”, “connected to” or “coupled to” another element or layer, it may be directly on, engaged, connected or coupled to the other element or layer, or intervening elements or layers may be present. In contrast, when an element is referred to as being “directly on,” “directly engaged to”, “directly connected to” or “directly coupled to” another element or layer, there may be no intervening elements or layers present. Other words used to describe the relationship between elements should be interpreted in a like fashion (*e.g.*, “between” versus “directly between,” “adjacent” versus “directly adjacent,” *etc.*). As used herein, the term “and/or” includes any and all combinations of one or more of the associated listed items.

[0041] The term “about” when applied to values indicates that the calculation or the measurement allows some slight imprecision in the value (with some approach to exactness in the value; approximately or reasonably close to the value; nearly). If, for some reason, the imprecision provided by “about” is not otherwise understood in the art with this ordinary meaning, then “about” as used herein indicates at least variations that may arise from ordinary methods of measuring or using such parameters. For example, the terms “generally”, “about”, and “substantially” may be used herein to mean within manufacturing tolerances. Whether or not modified by the term “about”, the claims include equivalents to the quantities.

[0042] Although the terms first, second, third, *etc.* may be used herein to describe various elements, components, regions, layers and/or sections, these elements, components, regions, layers and/or sections should not be limited by these terms. These terms may be only used to distinguish one element, component, region, layer or section from another region, layer or section. Terms such as “first,” “second,” and other numerical terms when used herein do not imply a sequence or order unless clearly indicated by the context. Thus, a first element, component, region, layer or section discussed below could be termed a second element, component, region, layer or section without departing from the teachings of the example embodiments.

[0043] Spatially relative terms, such as “inner,” “outer,” “beneath”, “below”, “lower”, “above”, “upper” and the like, may be used herein for ease of description to describe one element or feature’s relationship to another element(s) or feature(s) as illustrated in the figures. Spatially relative terms may be intended to encompass different orientations of the device in use or operation in addition to the orientation depicted in the figures. For example, if

the device in the figures is turned over, elements described as “below” or “beneath” other elements or features would then be oriented “above” the other elements or features. Thus, the example term “below” can encompass both an orientation of above and below. The device may be otherwise oriented (rotated 90 degrees or at other orientations) and the spatially relative descriptors used herein interpreted accordingly.

[0044] The foregoing description of the embodiments has been provided for purposes of illustration and description. It is not intended to be exhaustive or to limit the disclosure. Individual elements, intended or stated uses, or features of a particular embodiment are generally not limited to that particular embodiment, but, where applicable, are interchangeable and can be used in a selected embodiment, even if not specifically shown or described. The same may also be varied in many ways. Such variations are not to be regarded as a departure from the disclosure, and all such modifications are intended to be included within the scope of the disclosure.

CLAIMS

WHAT IS CLAIMED IS:

1. A shielding assembly suitable for use in providing electromagnetic interference (EMI) shielding for one or more components on a substrate, the shielding assembly comprising one or more soft and/or flexible walls dispensed and formed on the substrate.
2. The shielding assembly of claim 1, wherein the one or more soft and/or flexible walls are dispensed on the substrate as form-in-place material and/or by three-dimensional printing on the substrate.
3. The shielding assembly of claim 1, wherein:
the one or more soft and/or flexible walls are dispensed on the substrate by three-dimensional printing; and
one or more form-in-place gaskets are dispensed on the one or more soft and/or flexible walls.
4. The shielding assembly of claim 1, wherein the substrate comprises a cover for the one or more soft and/or flexible walls.
5. The shielding assembly of claim 1, further comprising a cover installed over the one or more soft and/or flexible walls such that the one or more components on the substrate are within an interior defined by the cover and the one or more soft and/or flexible walls.
6. The shielding assembly of claim 5, wherein the cover comprises one or more of an electrically-conductive fabric, a shielding film, a metal foil, and/or a tin-containing polyimide film.
7. The shielding assembly of claim 5, wherein the cover is adhered directly to the one or more soft and/or flexible walls.
8. The shielding assembly of any one of the preceding claims, wherein the one or more soft and/or flexible walls comprise electrically-conductive filler within a silicone, an elastomer material, and/or a plastic material.
9. The shielding assembly of any one of claims 1 to 7, wherein the one or more soft and/or flexible walls comprise silicone and electrically-conductive filler including one or more of silver, graphite, copper, aluminum, and/or nickel.
10. The shielding assembly of any one of claims 1 to 7, wherein the one or more soft and/or flexible walls comprise one or more of silver/nickel filled silicone elastomer form-in-

place material, nickel/graphite filled silicone material, silver/aluminum filled silicone elastomer form-in-place material, and/or silver/copper filled silicone elastomer form-in-place material.

11. The shielding assembly of any one of the preceding claims, wherein the one or more walls have a Shore A hardness within a range from about 55 to 70 and/or a tensile elongation of at least about 110%.

12. The shielding assembly of any one of the preceding claims, wherein the one or more walls have a height of less than 1.0 millimeters and a thickness of less than 0.6 millimeters.

13. The shielding assembly of any one of the preceding claims, wherein the shielding assembly has an overall height of less than 1.0 millimeter.

14. A method relating to providing shielding for one or more components on a substrate, the method comprising 3D printing material and/or dispensing a form-in-place material onto a substrate to thereby form one or more walls on the substrate that are disposed generally about the one or more components.

15. The method of claim 14, further comprising positioning a cover relative to the one or more walls such that the one or more components on the substrate are within an interior defined by the cover and the one or more walls.

16. The method of claim 15, further comprising attaching the cover to the one or more walls while the 3D printed material and/or form-in-place material forming the one or more walls is still curing.

17. The method of claim 14, wherein the substrate includes a cover for the one or more walls, and wherein the method further comprises installing the one or more walls and the cover onto a second substrate for shielding one or more components on the second substrate.

18. The method of claim 17, wherein the second substrate comprises a printed circuit board.

19. The method of any one of claims 14 to 18, wherein the method includes 3D printing material directly onto the substrate to thereby form one or more soft and/or flexible walls directly on the substrate.

20. The method of any one of claims 14 to 18, wherein the method includes dispensing a form-in-place material directly onto the substrate to thereby form one or more soft and/or flexible walls directly on the substrate.

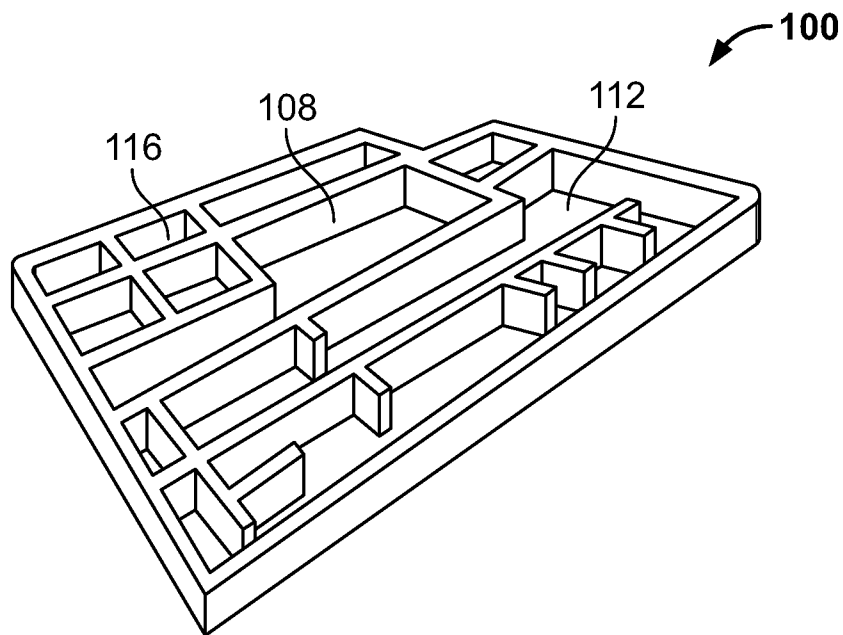

FIG. 1

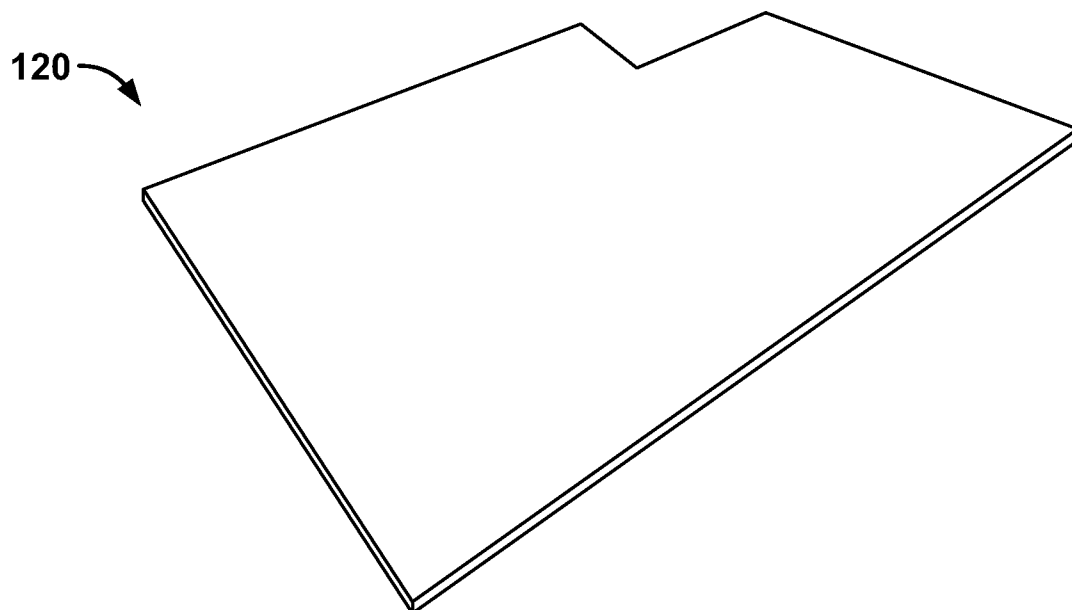

FIG. 2

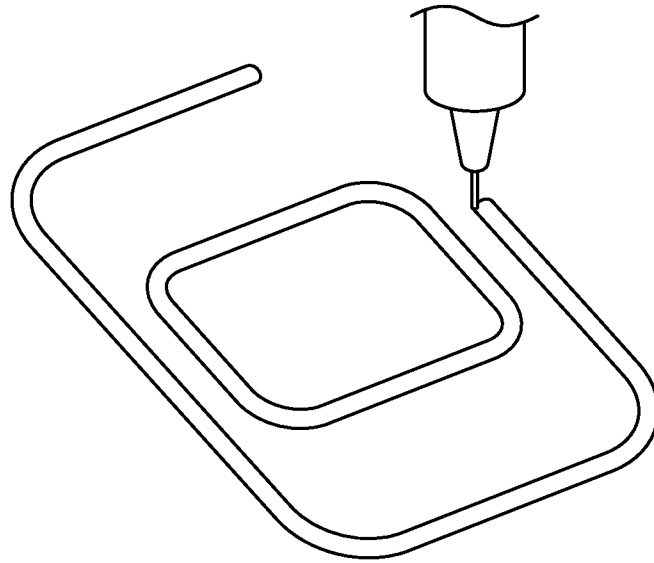

FIG. 3

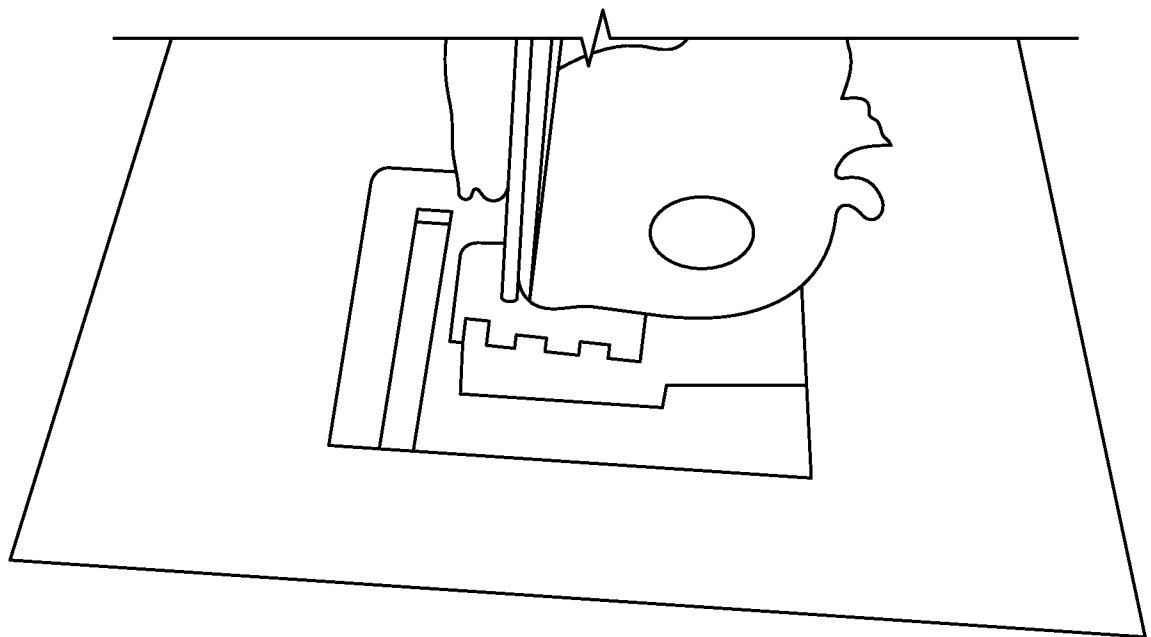

FIG. 4

A. CLASSIFICATION OF SUBJECT MATTER**H05K 9/00(2006.01)I**

According to International Patent Classification (IPC) or to both national classification and IPC

B. FIELDS SEARCHEDMinimum documentation searched (classification system followed by classification symbols)
H05K 9/00; B05D 3/02; H02G 3/00; B32B 15/04Documentation searched other than minimum documentation to the extent that such documents are included in the fields searched
Korean utility models and applications for utility models
Japanese utility models and applications for utility modelsElectronic data base consulted during the international search (name of data base and, where practicable, search terms used)
eKOMPASS(KIPO internal) & Keywords: electromagnetic interference shielding, form-in-place material, three-dimensional printing, soft and flexible wall**C. DOCUMENTS CONSIDERED TO BE RELEVANT**

Category*	Citation of document, with indication, where appropriate, of the relevant passages	Relevant to claim No.
X	US 2002-0039658 A1 (MICHAEL H. BUNYAN et al.) 04 April 2002 See abstract, paragraphs [0053]-[0056], claims 24-33, 47 and figures 3-4.	1-20
A	US 2001-0028558 A1 (MARTIN L. RAPP et al.) 11 October 2001 See paragraphs [0048]-[0050], claims 1, 16 and figure 6.	1-20
A	US 2006-0260839 A1 (ERIC G. KROHTO et al.) 23 November 2006 See paragraphs [0033]-[0038], [0052], claims 1, 17 and figures 1-2, 4.	1-20
A	US 2003-0173100 A1 (BRIAN F. FLAHERTY et al.) 18 September 2003 See paragraphs [0034]-[0035], [0049]-[0055], claims 1, 16 and figures 2a-4a.	1-20
A	US 2004-0020674 A1 (JEFF MCFADDEN et al.) 05 February 2004 See paragraphs [0041]-[0045], claims 1, 15 and figures 1A-3C.	1-20

 Further documents are listed in the continuation of Box C. See patent family annex.

* Special categories of cited documents:

"A" document defining the general state of the art which is not considered to be of particular relevance

"E" earlier application or patent but published on or after the international filing date

"L" document which may throw doubts on priority claim(s) or which is cited to establish the publication date of another citation or other special reason (as specified)

"O" document referring to an oral disclosure, use, exhibition or other means

"P" document published prior to the international filing date but later than the priority date claimed

"T" later document published after the international filing date or priority date and not in conflict with the application but cited to understand the principle or theory underlying the invention

"X" document of particular relevance; the claimed invention cannot be considered novel or cannot be considered to involve an inventive step when the document is taken alone

"Y" document of particular relevance; the claimed invention cannot be considered to involve an inventive step when the document is combined with one or more other such documents, such combination being obvious to a person skilled in the art

"&" document member of the same patent family

Date of the actual completion of the international search

29 July 2016 (29.07.2016)

Date of mailing of the international search report

29 July 2016 (29.07.2016)

Name and mailing address of the ISA/KR

International Application Division
Korean Intellectual Property Office
189 Cheongsa-ro, Seo-gu, Daejeon, 35208, Republic of Korea

Facsimile No. +82-42-481-8578

Authorized officer

KIM, Sung Gon

Telephone No. +82-42-481-8746

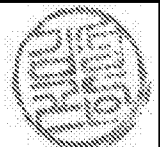

INTERNATIONAL SEARCH REPORT

Information on patent family members

International application No.

PCT/US2016/030662

Patent document cited in search report	Publication date	Patent family member(s)	Publication date		
US 2002-0039658 A1	04/04/2002	CA 2129073 A1	11/03/1995		
		CA 2129073 C	05/06/2007		
		CA 2210485 A1	25/07/1996		
		CA 2210485 C	20/07/2010		
		EP 0643551 A1	15/03/1995		
		EP 0643551 B1	05/04/2000		
		EP 0643552 A1	15/03/1995		
		EP 0804868 A1	16/08/2000		
		EP 0804868 B1	28/03/2001		
		EP 1020103 A1	19/07/2000		
		EP 1020103 B1	24/10/2001		
		EP 1041869 A2	04/10/2000		
		EP 1041869 B1	15/04/2009		
		JP 07-096962 A	11/04/1995		
		JP 11-500368 A	12/01/1999		
		JP 3971798 B2	05/09/2007		
		TW 550284 A	01/09/2003		
		US 2002-0076547 A1	20/06/2002		
		US 2007-0052125 A1	08/03/2007		
		US 5641438 A	24/06/1997		
		US 5910524 A	08/06/1999		
		US 6056527 A	02/05/2000		
		US 6096413 A	01/08/2000		
		US 6303180 B1	16/10/2001		
		US 6331349 B1	18/12/2001		
		US 6635354 B2	21/10/2003		
		WO 95-07603 A1	16/03/1995		
		WO 96-22672 A2	25/07/1996		
		WO 99-18765 A1	15/04/1999		
		US 2001-0028558 A1	11/10/2001	AU 2001-41847 A1	12/09/2001
				CA 2401168 A1	07/09/2001
				EP 1266549 A2	18/12/2002
				JP 2004-500714 A	08/01/2004
KR 10-2002-0086586 A	18/11/2002				
US 2002-0046849 A1	25/04/2002				
US 6652777 B2	25/11/2003				
WO 01-65903 A2	07/09/2001				
WO 01-65903 A3	09/01/2003				
US 2006-0260839 A1	23/11/2006			US 7446265 B2	04/11/2008
US 2003-0173100 A1	18/09/2003	CA 2421650 A1	15/09/2003		
		CA 2421650 C	19/06/2012		
		US 6723916 B2	20/04/2004		
US 2004-0020674 A1	05/02/2004	AU 2003-276809 A1	31/12/2003		
		WO 03-107729 A1	24/12/2003		